

TM 9-2330-324-14&P

TECHNICAL MANUAL

**OPERATOR'S, ORGANIZATIONAL, DIRECT SUPPORT,
AND GENERAL SUPPORT MAINTENANCE MANUAL
(INCLUDING REPAIR PARTS AND SPECIAL TOOLS LIST)
FOR TRAILER, CARGO: 1-1/2-TON, 2-WHEEL,
M105A3**

NSN 2330-01-452-1218

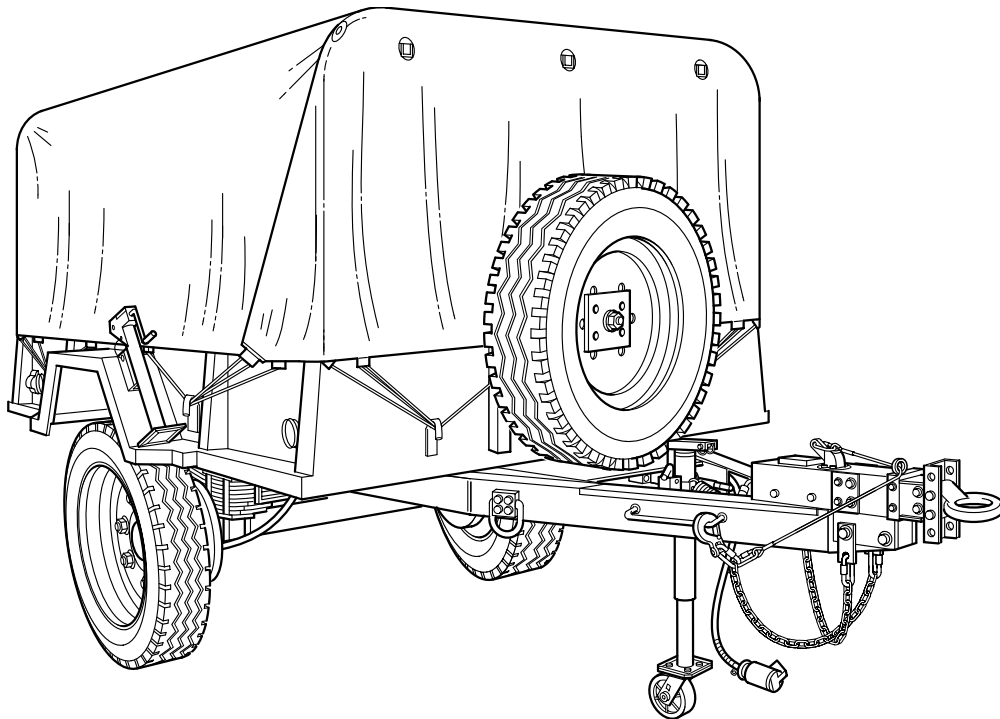

DISTRIBUTION STATEMENT A—Approved for public release; distribution is unlimited.

HEADQUARTERS, DEPARTMENT OF THE ARMY

7 July 2002

WARNING SUMMARY

This warning summary contains general safety precautions and instructions that must be understood and applied during the operation and maintenance of the M105A3 Trailer to ensure personnel against injury, long-term health hazards, or death.

WARNING

COUPLING AND UNCOUPLING TRAILER

- All personnel must stand clear of towing vehicle and trailer during coupling and uncoupling operations. Failure to follow this warning may result in serious injury or death.
- Drawbar is heavy—up to 400 lb (181 kg) loaded tongue weight. Do not attempt to lift drawbar. Use landing gear to raise and lower drawbar. Failure to follow this warning may result in serious injury or death.

WARNING

TOWING TRAILER

Before moving trailer, ensure that all loose equipment is properly stowed and that nothing will drag on ground. If trailer is loaded, ensure that load is properly secured. Make sure landing gear is rotated up and locked in transport position. Failure to follow this warning may result in injury to personnel or damage to equipment.

WARNING

LOADING TRAILER

If trailer is not connected to towing vehicle, use stabilizer when loading heavy loads. Failure to follow this warning may result in trailer tipping backward causing serious injury or death.

WARNING

CLEANING COMPOUND

Solvents can burn easily, can give off harmful vapors, and are harmful to skin and clothing. To avoid injury or death, keep away from open fire and use in a well-ventilated area. If solvent gets on skin or clothing, wash immediately with soap and water.

WARNING SUMMARY—Continued

WARNING

ELECTRICAL SYSTEM MAINTENANCE

Make sure all electrical power is disconnected before performing any maintenance on electrical system. Serious injury or death may result if proper precautions are not taken.

WARNING

HANDBRAKE MAINTENANCE

If trailer is not coupled to towing vehicle, ensure that landing gear is lowered and locked and wheels are securely chocked. Failure to follow this warning may cause trailer to roll, resulting in injury to personnel or damage to equipment.

WARNING

WHEEL REPLACEMENT

Wheel weighs 185 lb (84 kg). Use two people to replace wheel. Failure to follow this warning could result in serious injury to personnel.

WARNING

LUBRICATION

Wipe excess lubricant from area of brakeshoe linings to avoid grease soaking linings. If brakeshoe linings become soaked, have Organizational maintenance replace them. Failure to follow this warning may cause brakes to malfunction, resulting in serious injury or death.

WARNING

CLEANING

Improper cleaning methods and use of unauthorized cleaning liquids or solvents can injure personnel and damage equipment. To prevent this, refer to TM 9-247 for further instructions.

WARNING

COMPRESSED AIR

Compressed air used for cleaning or drying purposes, or for clearing restrictions, should never exceed 30 psi (207 kPa). Wear protective clothing (goggles/shield, gloves, etc.) and use caution to avoid injury to personnel.

WARNING SUMMARY—Continued

WARNING

SERVICE BRAKE MAINTENANCE

Do not handle brakeshoes, brakedrums, or other brake components unless area has been properly cleaned. There may be hazardous dust on these components which can be dangerous if you touch it or breathe it. Wear an approved filter mask and gloves. Never use compressed air or a dry brush to clean brake components. Dust may be removed using an industrial-type vacuum cleaner. Clean dust or mud away from brake components with water and a wet, soft cloth. Failure to follow this warning may result in serious illness or death.

WARNING

EMERGENCY BRAKING BREAKAWAY LEVER RESET

Keep hands and fingers clear when resetting breakaway lever. Hydraulic pressure held in system may cause breakaway lever to snap back quickly. Failure to follow this warning may result in injury to personnel.

WARNING

BLEEDING BRAKE SYSTEM

- When performing maintenance on brake system, ensure that landing gear is lowered and locked and that wheels are securely chocked. Failure to follow this warning may cause trailer to roll, resulting in serious injury or death to personnel.
- Eye injury may result if brake fluid comes in contact with eyes. Always wear eye protection when working with brake fluid. Failure to follow this warning may result in injury to personnel.
- Use only fresh brake fluid from a sealed container; do not reuse fluid. After filling and bleeding, be sure to refill master cylinder to 3/4 full. Failure to maintain an adequate fluid level may cause brake failure, resulting in injury to personnel or damage to equipment.

WARNING

REAR AXLE MAINTENANCE

Axle is heavy and awkward to handle. Use caution; weight of trailer must be supported by leveling jacks or by blocking or support stands on corner of rear crossmember throughout operations. Use assistance during removal. Failure to follow this warning may result in serious injury.

WARNING SUMMARY—Continued

WARNING

BRAKEDRUM REPAIR

Do not use a brakedrum that exceeds maximum wear specifications. Failure to follow this warning may result in brake failure and serious injury or death.

WARNING

CARGO BODY MAINTENANCE

To raise or lower cargo body, cargo tiedowns will be connected to a lifting device. While this operation is being performed, stand clear. Failure to follow this warning may result in serious injury or death.

CHANGE
NO. 1

HEADQUARTERS
DEPARTMENT OF THE ARMY
WASHINGTON, D.C., 10 APRIL 2006

TECHNICAL MANUAL

**OPERATOR'S, ORGANIZATIONAL, DIRECT SUPPORT, AND
GENERAL SUPPORT MAINTENANCE MANUAL
(INCLUDING REPAIR PARTS AND SPECIAL TOOLS LIST)
FOR
TRAILER, CARGO: 1-1/2-TON, 2-WHEEL,
M105A3
(NSN 2330-01-452-1218)**

CURRENT AS OF 10 APRIL 2006

DISTRIBUTION STATEMENT A – Approved for public release; distribution is unlimited.

TM 9-2330-324-14&P, 7 July 2002, is updated as follows:

1. File this sheet in front of the manual for reference.
2. New or updated text is indicated by a vertical bar in the outer margin of the page.
3. This change implements Army Maintenance Transformation and changes the Maintenance Allocation Chart (MAC) to support Field and Sustainment Maintenance.
4. Remove old pages and insert new pages as indicated below.

Remove Pages

LOEP

0007 00-5 and 0007 00-6

0051 00-5/(6 Blank)

Insert Pages

LOEP

0007 00-5 and 0007 00-6

0051 00-5/(6 Blank)

5. Replace the following work packages with their revised versions.

Work Package Number

0057 00

0058 00

By Order of the Secretary of the Army:

Official:



JOYCE E. MORROW

*Administrative Assistant to the
Secretary of the Army*

0607433

PETER J. SCHOOMAKER
*General, United States Army
Chief of Staff*

Distribution:

To be distributed in accordance with the initial distribution number (IDN) 391036,
requirements for TM 9-2330-324-14&P.

LIST OF EFFECTIVE PAGES

Date of issue for version:

Original: **0** **07 July 2002**
Change -1 **1** **10 April 2006**

TOTAL NUMBER OF PAGES FOR FRONT AND REAR MATTER IS 32 AND TOTAL NUMBER OF WORK PACKAGES IS 86, CONSISTING OF THE FOLLOWING:

Page/WP No.	*Change. No.
<i>Title</i>	<i>0</i>
<i>A</i>	<i>0</i>
<i>i-viii</i>	<i>0</i>
<i>WP 0001-0056</i>	<i>0</i>
<i>WP 0057-0058</i>	<i>1</i>
<i>WP 0059-0086 00</i>	<i>0</i>

**Zero in this column indicates an original page.*

TM 9-2330-324-14&P

TECHNICAL MANUAL

OPERATOR'S, ORGANIZATIONAL, DIRECT SUPPORT, AND
GENERAL SUPPORT MAINTENANCE MANUAL
(INCLUDING REPAIR PARTS AND SPECIAL TOOLS LIST)

for

TRAILER, CARGO: 1-1/2-TON, 2-WHEEL,
M105A3

NSN 2330-01-452-1218

REPORTING ERRORS AND RECOMMENDING IMPROVEMENTS

You can help improve this manual. If you find any mistakes or if you know of a way to improve the procedures, please let us know. Mail your letter, DA Form 2028 (Recommended Changes to Publications and Blank Forms), or DA Form 2028-2 located in the back of this manual, direct to COMMANDER, U.S. Army Tank-automotive and Armaments Command, ATTN: AMSTA-LC-CIP-WT, Rock Island, IL 61299-7630. A reply will be furnished to you.

DISTRIBUTION STATEMENT A—Approved for public release: distribution is unlimited.

HEADQUARTERS, DEPARTMENT OF THE ARMY

7 July 2002

TABLE OF CONTENTS

	<u>WP Sequence No.</u>
CHAPTER 1: INTRODUCTORY INFORMATION WITH THEORY OF OPERATION	
Trailer General Information.....	0001 00
Trailer Equipment Description and Data.....	0002 00
Electrical System Theory of Operation.....	0003 00
Brake System Theory of Operation.....	0004 00
Repair Parts; Special Tools; Test, Measurement, and Diagnostic Equipment (TMDE); and Support Equipment.....	0005 00
CHAPTER 2: OPERATOR INSTRUCTIONS	
Description and Use of Controls and Indicators.....	0006 00
Operation Under Usual Conditions.....	0007 00
Operation Under Unusual Conditions.....	0008 00
CHAPTER 3: OPERATOR TROUBLESHOOTING PROCEDURES	
Introduction.....	0009 00
Malfunction/System Index.....	0010 00
Electrical System Operator/Crew Troubleshooting.....	0011 00
Brake System Operator/Crew Troubleshooting.....	0012 00
CHAPTER 4: ORGANIZATIONAL TROUBLESHOOTING PROCEDURES	
Introduction.....	0013 00
Malfunction/System Index.....	0014 00
Electrical System Organizational Troubleshooting.....	0015 00
Brake System Organizational Troubleshooting.....	0016 00
CHAPTER 5: OPERATOR MAINTENANCE	
Operator/Crew Preventive Maintenance Checks and Services (PMCS).....	0017 00
Operator/Crew Lubrication Instructions.....	0018 00
Handbrake Lever Adjustment.....	0019 00
Wheel Replacement.....	0020 00
CHAPTER 6: ORGANIZATIONAL MAINTENANCE	
Service Upon Receipt.....	0021 00
Organizational Preventive Maintenance Checks and Services (PMCS).....	0022 00
Organizational Lubrication Instructions.....	0023 00
General Maintenance Instructions.....	0024 00
Electrical Schematic.....	0025 00
Composite Light Maintenance.....	0026 00
Running Light Maintenance.....	0027 00
Chassis Wiring Harness Maintenance.....	0028 00
Intervehicular Cable Assembly Maintenance.....	0029 00
Wiring Harness and Cable Assembly Repair.....	0030 00
Handbrake Lever Replacement.....	0031 00
Handbrake Linkage and Cables Maintenance.....	0032 00
Service Brake Assembly Maintenance.....	0033 00
Brake Actuator Replacement.....	0034 00
Emergency Braking Breakaway Lever Reset.....	0035 00
Wheel Cylinder Replacement.....	0036 00
Hydraulic Brake Lines and Fittings Replacement.....	0037 00
Bleeding Brake System.....	0038 00
Brakedrum, Wheel Hub, and Wheel Bearing Maintenance.....	0039 00

TABLE OF CONTENTS—Continued

	<u>WP Sequence No.</u>
CHAPTER 6: ORGANIZATIONAL MAINTENANCE—Continued	
Tire Maintenance	0040 00
Drawbar Coupler Replacement	0041 00
Safety Chain Replacement	0042 00
Landing Gear Maintenance	0043 00
Spring Maintenance	0044 00
Cargo Tiedown Replacement	0045 00
Tailgate Replacement	0046 00
Spare Wheel Rack Maintenance	0047 00
D-Ring Replacement	0048 00
Reflector Replacement	0049 00
Data Plate Replacement	0050 00
Preparation for Storage or Shipment	0051 00
CHAPTER 7: DIRECT SUPPORT AND GENERAL SUPPORT MAINTENANCE	
Axle Replacement	0052 00
Brakedrum Repair	0053 00
Tire Repair	0054 00
Frame Assembly Repair	0055 00
Cargo Body Maintenance	0056 00
CHAPTER 8: SUPPORTING INFORMATION	
References	0057 00
Maintenance Allocation Chart (MAC)	0058 00
Additional Authorization List (AAL)	0059 00
Expendable and Durable Items List	0060 00
Mandatory Replacement Items List	0061 00
Repair Parts and Special Tools List (RPSTL):	
Introduction	0062 00
Group 0609—Rear Composite Marker Lights	0063 00
Group 0609—Running Lights	0064 00
Group 0613—Chassis Wiring Harness	0065 00
Group 1100—Rear Axle	0066 00
Group 1201—Handbrake Linkage	0067 00
Group 1202—Service Brakes	0068 00
Group 1204—Brakes Actuator	0069 00
Group 1204—Wheel Cylinders	0070 00
Group 1204—Hydraulic Brake Lines and Fittings	0071 00
Group 1311—Wheel and Hub	0072 00
Group 1313—Tires	0073 00
Group 1503—Drawbar Ring and Safety Chain	0074 00
Group 1503—D-Rings	0075 00
Group 1507—Landing Gear	0076 00
Group 1507—Stabilizer	0077 00
Group 1601—Main and Auxiliary Springs	0078 00
Group 1810—Cargo Body	0079 00
Group 1810—Tailgate	0080 00
Group 1810—Spare Wheel Rack	0081 00
Group 2202—Reflectors	0082 00
Group 2210—Data Plates	0083 00
National Stock Number Index	0084 00
Part Number Index	0085 00
Torque Limits	0086 00

HOW TO USE THIS MANUAL

SCOPE

This manual provides you with the information you will need to operate and maintain the M105A3 Trailer.

MANUAL CONTENT

The front matter in this manual consists of general warnings, title block page, and table of contents.

The information contained in this manual is presented in eight chapters. Each chapter is divided into Work Packages (WPs) that cover operating procedures, maintenance procedures, troubleshooting procedures, and other information for specific systems or components. Each WP starts on a right-hand page. Page numbers consist of the WP number followed by a dash and another number. For example, "0014 00-7" means WP 0014 00, page 7.

At the end of this manual are an alphabetical index, DA Form 2028-2, and metric conversion chart.

Front Matter

There are general warnings that start on the first right-hand page immediately after the cover that should be read before performing any maintenance on the trailer.

The title block page includes the reporting of errors and recommending improvements statement.

The table of contents lists the chapters and WPs in this manual.

Chapters

Chapter 1 provides general information, equipment description, and theory of operation.

Chapter 2 provides the description and use of controls and indicators, and operating instructions.

Chapter 3 provides Operator troubleshooting procedures.

Chapter 4 provides Organizational troubleshooting procedures.

Chapter 5 provides Operator maintenance instructions.

Chapter 6 provides Organizational maintenance instructions.

Chapter 7 provides Direct Support and General Support maintenance instructions.

Chapter 8 provides supporting information, including the titles of documents and publications referenced in this manual, Maintenance Allocation Chart (MAC), Additional Authorization List (AAL), expendable and durable items list, mandatory replacement parts list, Repair Parts and Special Tools List (RPSTL), and torque limits.

Alphabetical Index

An index is located after the last WP in this manual that provides an alphabetical listing of information and components/assemblies contained in this manual.

HOW TO USE THIS MANUAL—Continued

DA Form 2028-2

DA Form 2028-2 is used to report errors and to recommend improvements for the tasks in this manual.

Metric Conversion Chart

The metric conversion chart converts English measurements to metric equivalents. Measurements in this manual are provided in both English and metric units.

WARNINGS, CAUTIONS, AND NOTES

You must read and understand this manual BEFORE operating the trailer.

Throughout this manual you will see **WARNING**, **CAUTION**, and **NOTE** headings. There are good reasons for every one of these notices:

WARNING

A warning is used to alert the user to hazardous operating and maintenance procedures, practices, or conditions that could result in injury or death. Warnings must be strictly observed.

CAUTION

A caution is used to alert the user to hazardous operating and maintenance procedures, practices, or conditions that could result in damage to, or destruction of, equipment or mission effectiveness. Cautions must be strictly observed.

NOTE

A note highlights an essential operating or maintenance procedure, condition, or statement.

Warnings and cautions appear immediately preceding the step to which they pertain. It is important to read and thoroughly understand the warnings and/or cautions before beginning maintenance. Notes may precede or follow the steps to which they pertain, depending on what makes the most sense.

INITIAL SETUPS

Before starting a task, you must obtain all the tools, supplies, and personnel listed in the initial setup. Be sure to read the task before performing the maintenance. If any other tasks are referenced, you must go to the initial setup page for each of those tasks to find out what tools, supplies, and personnel will be needed.

INDEXING

Four indexing procedures are used in this manual to help you locate information quickly:

- Table of contents
- Major components index on page 0002 00-2
- Controls and indicators index on page 0006 00-1
- Alphabetical index at the back of this manual

CHAPTER 1
INTRODUCTORY INFORMATION
WITH
THEORY OF OPERATION
FOR
M105A3 CARGO TRAILER

TRAILER GENERAL INFORMATION

0001 00

TYPE OF MANUAL

TM 9-2330-324-14&P is an Operator's, Organizational, Direct Support, and General Support Maintenance Manual (including Repair Parts and Special Tools List).

MODEL NUMBER AND EQUIPMENT NAME

This manual covers: Trailer, Cargo: 1-1/2-Ton, 2-Wheel, M105A3.

PURPOSE OF EQUIPMENT

The purpose of this trailer is to carry cargo for administrative and tactical operations.

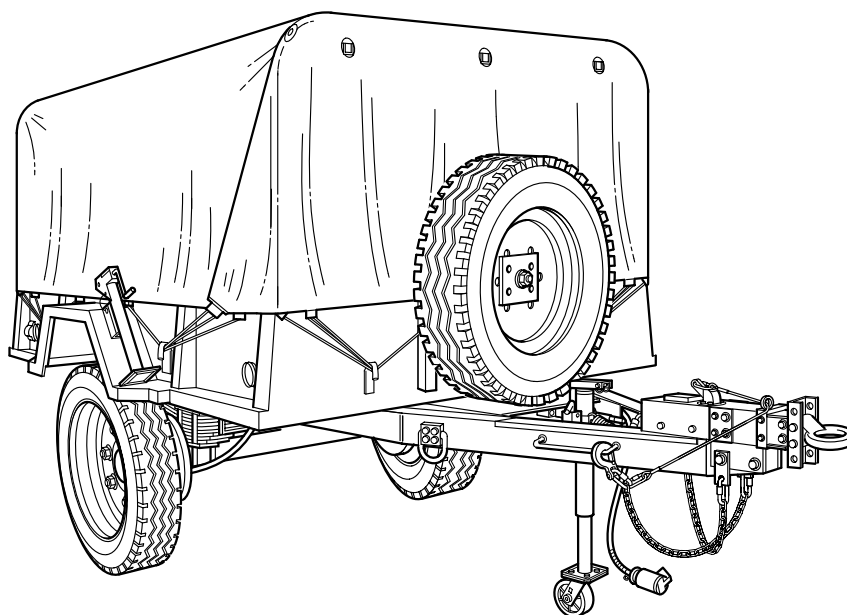

M105A3 Cargo Trailer

MAINTENANCE FORMS, RECORDS, AND REPORTS

Department of the Army forms and procedures used for equipment maintenance will be those prescribed by DA PAM 738-750, Functional Users Manual for The Army Maintenance Management System (TAMMS), or AR 700-138, Army Logistics Readiness and Sustainability.

REPORTING EQUIPMENT IMPROVEMENT RECOMMENDATIONS (EIRs)

If your trailer needs improvement, let us know. Send us an Equipment Improvement Recommendation (EIR). You, the user, are the only one who can tell us what you don't like about your equipment. Let us know why you don't like the design. Put it on an SF 368 (Product Quality Deficiency Report). Mail it to the address specified in DA PAM 738-750, Functional Users Manual for The Army Maintenance Management System (TAMMS), or as specified by the contracting activity. We will send you a reply.

CORROSION PREVENTION AND CONTROL (CPC)

Corrosion Prevention and Control (CPC) of Army materiel is a continuing concern. It is important that any corrosion problems with this item be reported so that the problem can be corrected and improvements can be made to prevent the problem in future items.

While corrosion is typically associated with rusting of metals, it can also include deterioration of other materials, such as rubber and plastic. Unusual cracking, softening, swelling, or breaking of these materials may be a corrosion problem.

If a corrosion problem is identified, it can be reported using SF 368, Product Maintenance Deficiency Report. Use of key words such as “corrosion,” “rust,” “deterioration,” or “cracking” will ensure that the information is identified as a CPC problem.

The form should be submitted to the address specified in DA PAM 738-750, Functional Users Manual for The Army Maintenance Management System (TAMMS).

DESTRUCTION OF ARMY MATERIEL TO PREVENT ENEMY USE

For destruction of Army materiel to prevent enemy use, refer to TM 750-244-6.

LIST OF ABBREVIATIONS/ACRONYMS

AAL.....	Additional Authorized Items
CAGEC.....	Commercial and Government Entity Code
cm.....	centimeters
CPC.....	Corrosion Prevention and Control
dc.....	direct current
DS.....	Direct Support
EA.....	each
EIR.....	Equipment Improvement Recommendation
FMTV.....	Family of Medium Tactical Vehicles
GL.....	gallon
GS.....	General Support
in.....	inches
kg.....	kilograms
km/h.....	kilometers per hour
kPa.....	kilopascals
LB.....	pounds
lb-ft.....	pound-feet
MAC.....	Maintenance Allocation Chart
mm.....	millimeters
mph.....	miles per hour
MTOE.....	Modified Table of Organization and Equipment
MWO.....	Modification Work Order
NATO.....	North Atlantic Treaty Organization
NSN.....	National Stock Number
N•m.....	Newton-meters
P/N.....	Part Number
PMCS.....	Preventive Maintenance Checks and Services
psi.....	pounds per square inch
QTY REQ.....	Quantity Required

LIST OF ABBREVIATIONS/ACRONYMS—Continued

REF.....	Reference
RL.....	roll
RPSTL.....	Repair Parts and Special Tools List
SC.....	Supply Catalog
SMR.....	Source, Maintenance, and Recoverability
SRA.....	Specialized Repair Activity
TAMMS.....	The Army Maintenance Management System
TAMMS-A.....	The Army Maintenance Management System—Aviation
TM.....	Technical Manual
TMDE.....	Test, Measurement, and Diagnostic Equipment
TOE.....	Table of Organization and Equipment
U/M.....	Unit of Measure
UUT.....	Unit Under Test
V.....	volts
WP.....	Work Package

TRAILER EQUIPMENT DESCRIPTION AND DATA

0002 00

EQUIPMENT CHARACTERISTICS, CAPABILITIES, AND FEATURES

The M105A3 Trailer carries a maximum payload of 3000 lb (1361 kg) either highway or cross-country.

The trailer is designed to be towed by the following vehicles:

1. M35, M36, M54, M55, M813, M814, M923, M927, and M939 Series Trucks.
2. M1078, M1079, M1081, M1083, M1084, M1085, and M1086 Family of Medium Tactical Vehicles (FMTV).

The maximum towing speeds are:

1. Highway—50 mph (80.5 km/h).
2. Cross-Country—30 mph (48.3 km/h).

The trailer is equipped with:

1. A 24 V dc electrical system capable of operating under standard and blackout modes.
2. Two-wheel single axle with multi-leaf spring suspension that absorbs road shock.
3. An hydraulic surge brake system.
4. An automatic emergency braking breakaway system that will apply the trailer brakes in the event of trailer breakaway from the towing vehicle.
5. A manually operated parking brake to secure the trailer when stopped or parked.
6. An adjustable landing gear with caster to support the front of the trailer when uncoupled from the towing vehicle.
7. A ladder mounted on the inside of the tailgate that swings down when the tailgate is open, providing easier access to the cargo body.
8. A spare wheel that is stowed in front of the cargo body.
9. A stabilizer for changing the wheels that is stowed outside the cargo body and can be mounted on built-in mounts that are located under both sides of the trailer at the rear. The stabilizer is also used to level and stabilize the trailer.

LOCATION AND DESCRIPTION OF MAJOR COMPONENTS

The following pages show the location and description of the major components of the trailer. Below is an alphabetical listing of them and the page number on which they can be found.

	<u>Page Number</u>
Brake System:	
Bracket	0002 00-7
Brakedrums	0002 00-7
Brake Actuator	0002 00-3, 0002 00-7
Brakeshoes	0002 00-7
Clamps	0002 00-7
Clip	0002 00-7
Emergency Braking Breakaway Cable	0002 00-3
Emergency Braking Breakaway Lever	0002 00-3
Hoses	0002 00-7
Tubes	0002 00-7
Wheel Cylinders	0002 00-7
Cargo Body	0002 00-4
Cargo Tiedowns	0002 00-4
Chassis Wiring Harness	0002 00-5
Composite Lights	0002 00-4, 0002 00-5
Drawbar Coupler	0002 00-3
D-Rings	0002 00-3
Electrical System:	
Chassis Wiring Harness	0002 00-5
Composite Lights	0002 00-4, 0002 00-5
Intervehicular Cable Assembly	0002 00-3, 0002 00-5
Running Lights	0002 00-4, 0002 00-5
Frame Assembly	0002 00-3
Handbrake:	
Brake Shaft Assembly	0002 00-6
Handbrake Lever	0002 00-3, 0002 00-6
Rod	0002 00-6
Handles	0002 00-3
Intervehicular Cable Assembly	0002 00-3, 0002 00-5
Ladder	0002 00-4
Landing Gear	0002 00-3
Lashing Hooks	0002 00-4
Multi-Leaf Springs	0002 00-3
Reflectors	0002 00-4
Roof Bows	0002 00-4
Running Lights	0002 00-4, 0002 00-5
Safety Chains	0002 00-3
Spare Wheel	0002 00-3
Stabilizer	0002 00-4
Stabilizer Mounts	0002 00-4
Stake Racks	0002 00-4
Tailgate	0002 00-4
Tarpaulin	0002 00-4

LOCATION AND DESCRIPTION OF MAJOR COMPONENTS—Continued

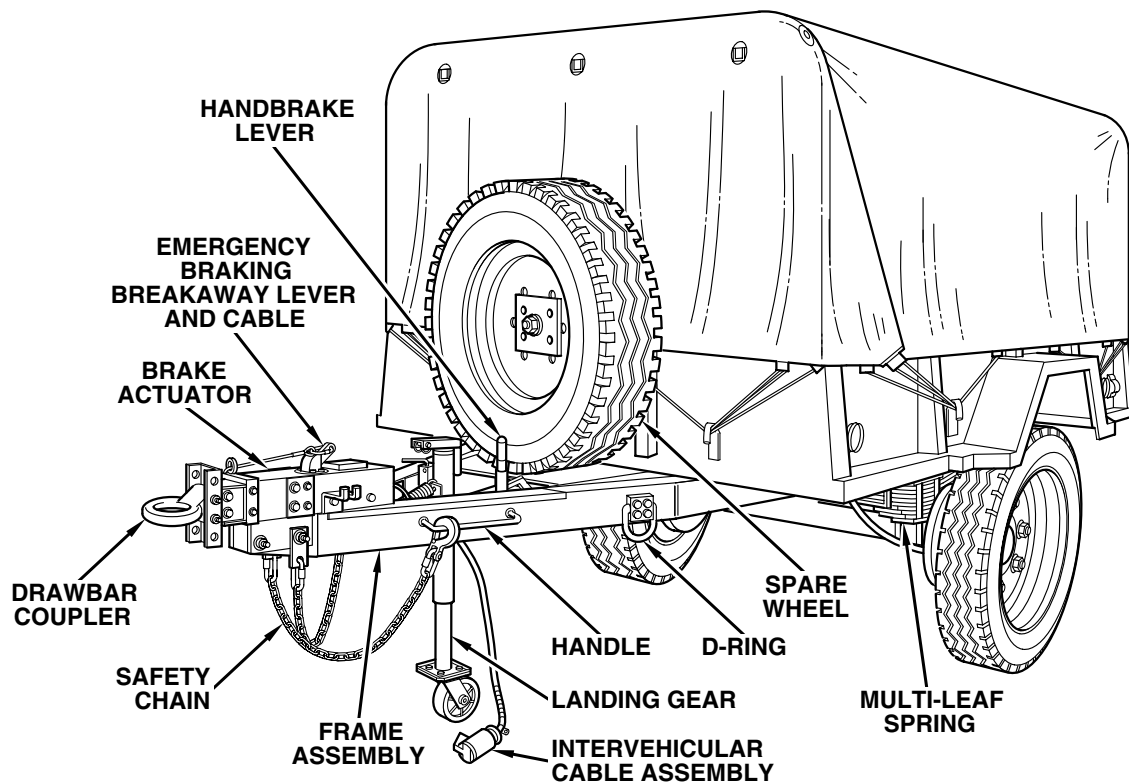

The **frame assembly** is composed of two formed-steel main rails reinforced by six formed-steel crossmembers. The **drawbar coupler** is used to couple the trailer to the towing vehicle pintle. The two **handles** are used to maneuver the trailer by hand. The two **safety chains** hook to eyebolts on the towing vehicle to prevent the trailer from fully breaking away. The **landing gear** supports the trailer tongue when not coupled to the towing vehicle; the **landing gear** is adjustable, has a caster, and has a swivel mount allowing it to rotate up for added clearance. The four **D-rings** are used to secure the trailer onto a transport or to lift the trailer. The **multi-leaf springs** cushion road shock.

The **spare wheel** is used to replace a wheel.

The **brake actuator** uses the trailer's momentum to engage the trailer brakes when the towing vehicle slows down and stops. The **emergency braking breakaway lever and cable** engage the trailer brakes if the trailer separates from the towing vehicle. The **handbrake lever** is used to engage the parking brake when the trailer is stopped or parked.

The **intervehicular cable assembly** connects to the towing vehicle's receptacle.

LOCATION AND DESCRIPTION OF MAJOR COMPONENTS—Continued

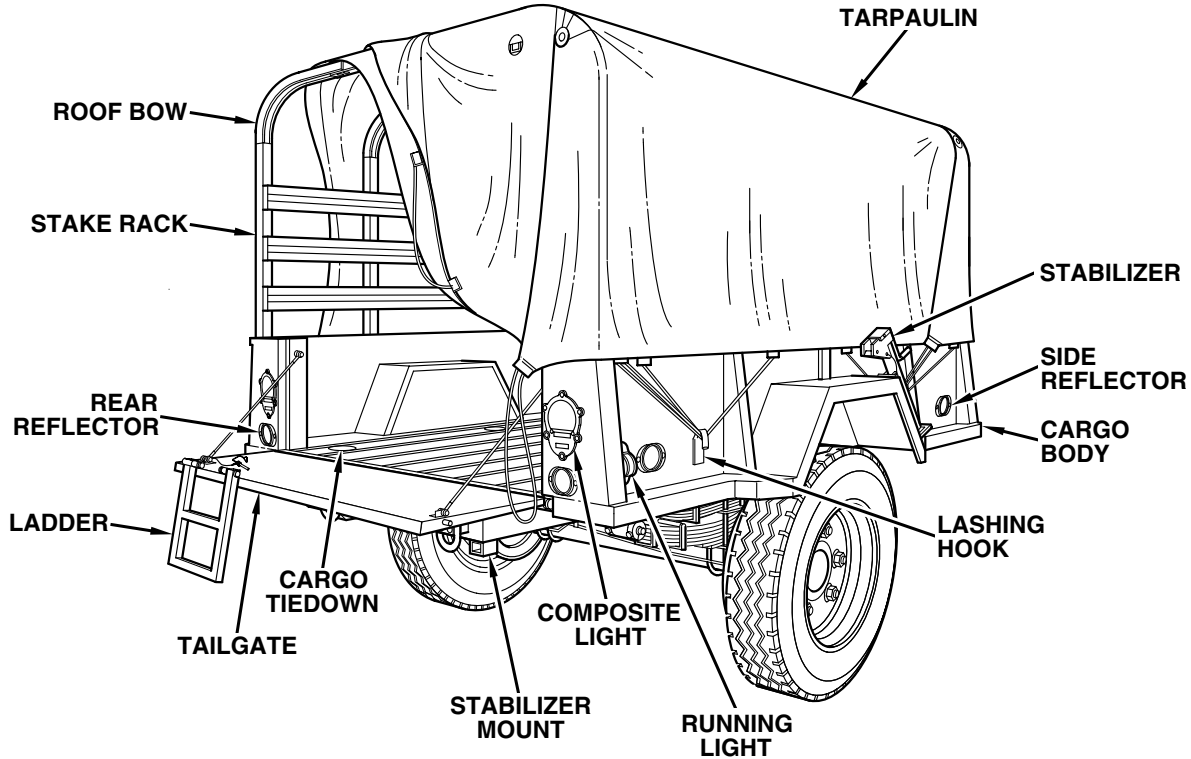

The **cargo body** is one-piece welded construction that can carry a maximum payload of 3000 lb (1361 kg). The **stake racks** vertically extend the **cargo body** to provide a larger cargo area. The **tailgate** provides access to the trailer's cargo. The six **cargo tiedowns** are used to secure cargo in the **cargo body**. The **ladder** is mounted on the inside of the **tailgate** and swings down when the **tailgate** is open. The **stabilizer** is used to lift one side of the trailer when changing a wheel. The two **stabilizer mounts** hold the **stabilizer** in place.

The **tarpaulin** is used to protect the cargo from inclement weather. The **tarpaulin** is reversible. The **roof bows** provide support for the **tarpaulin**. The **lashing hooks** attach the **tarpaulin** to the **cargo body**.

The two **composite lights** are used as the taillights, stoplights, and turning signals to indicate the presence and movement of the trailer to other vehicles traveling behind; the **composite lights** also have blackout capability. The two **rear reflectors** and three **rear running lights** indicate the trailer's presence to vehicles traveling behind the trailer. The four **side reflectors** and two **side running lights** indicate the trailer's presence to other vehicles traveling next to the trailer.

LOCATION AND DESCRIPTION OF MAJOR COMPONENTS—Continued

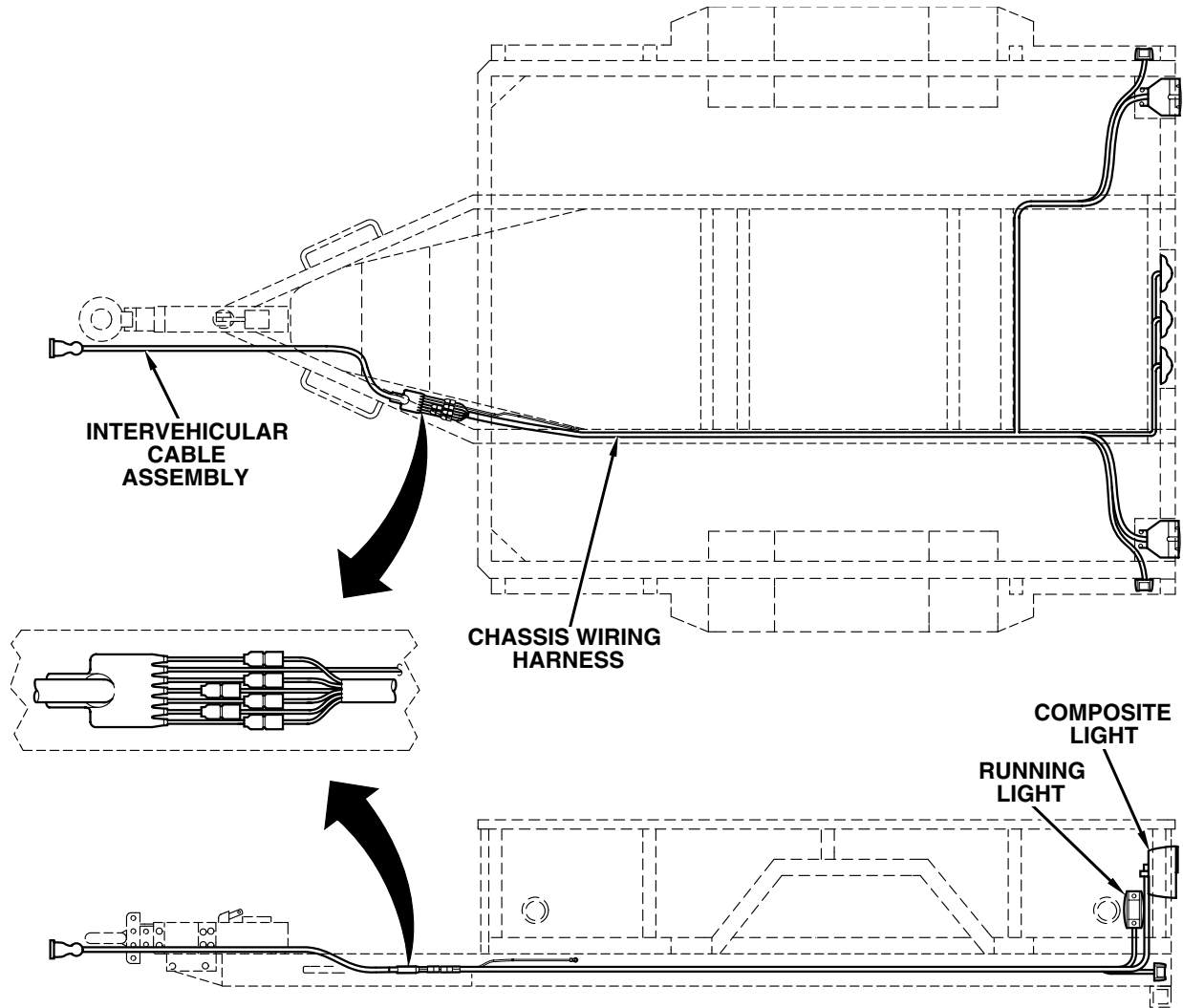

The **intervehicular cable assembly** and **chassis wiring harness** carry electrical current from the towing vehicle electrical system to the trailer **composite** and **running lights**.

LOCATION AND DESCRIPTION OF MAJOR COMPONENTS—Continued

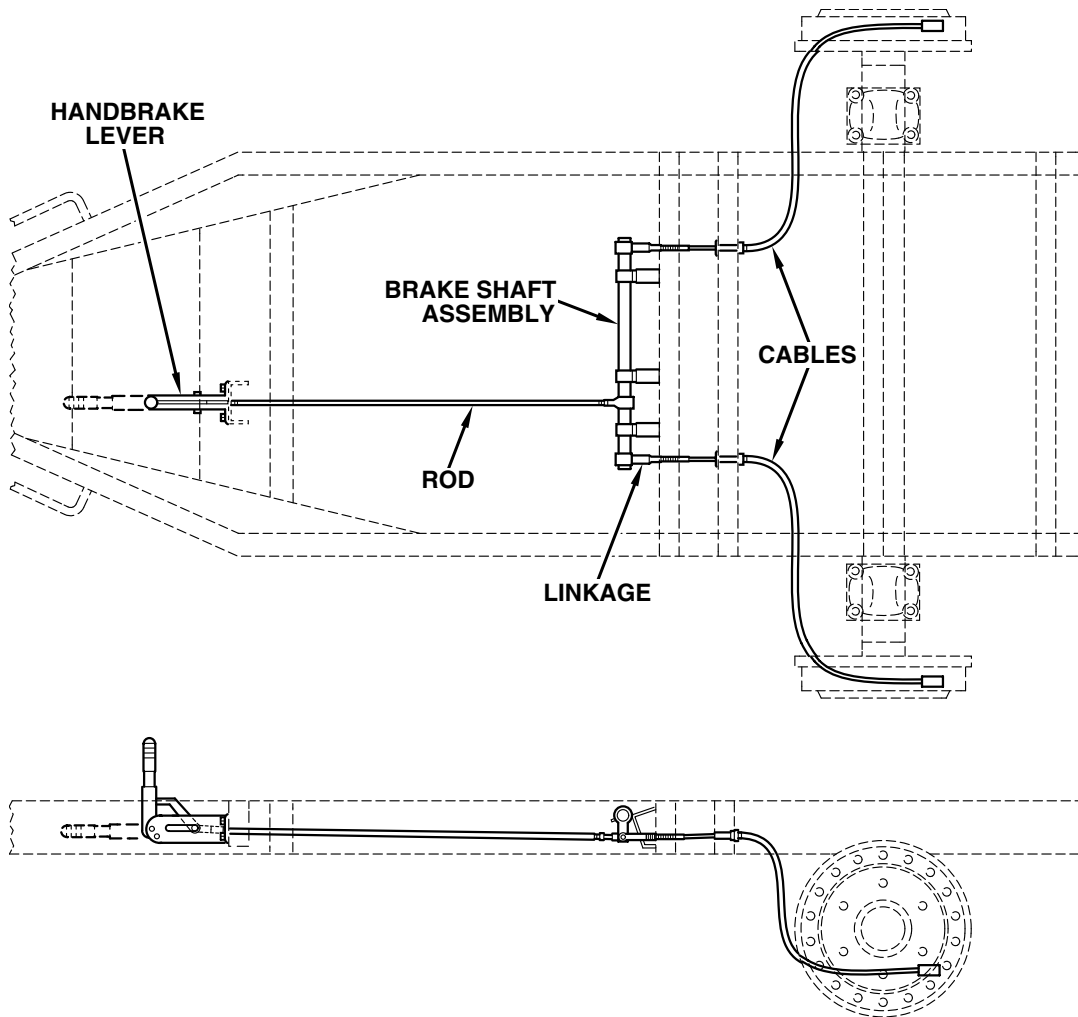

The handbrake **rod**, **brake shaft assembly**, **linkage**, and **cables** transfer mechanical motion from the **handbrake lever** to the brakeshoes.

LOCATION AND DESCRIPTION OF MAJOR COMPONENTS—Continued

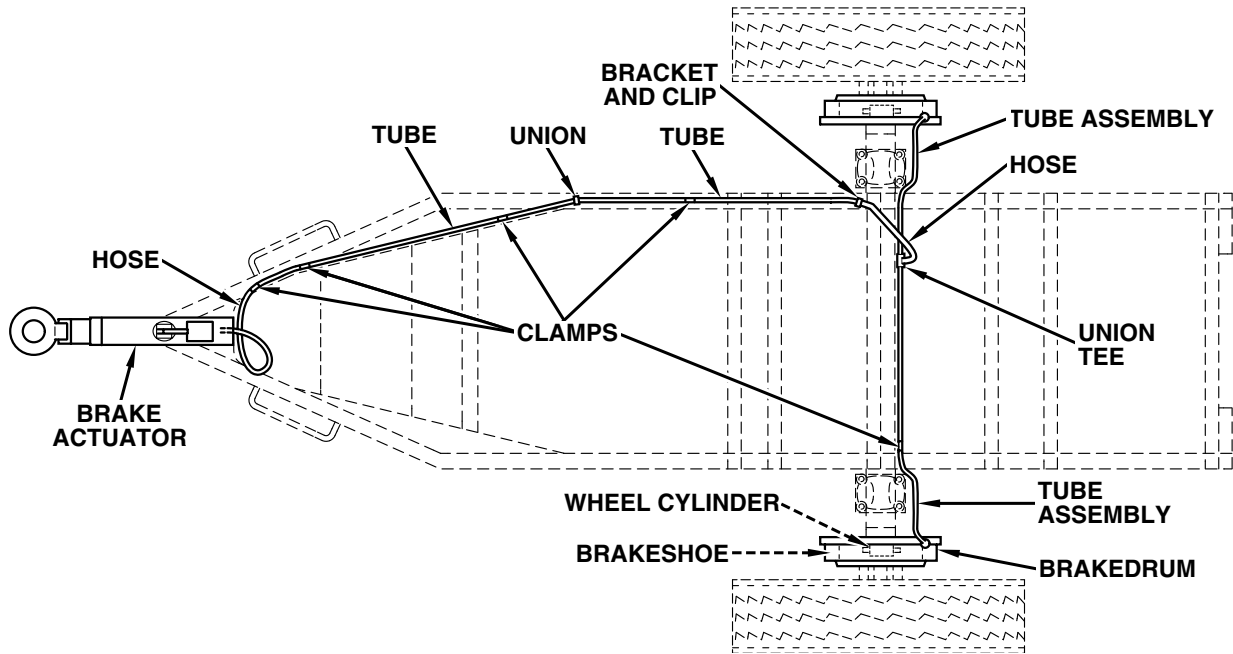

The hydraulic brake **hoses, tubes, and tube assemblies** transfer hydraulic pressure from the **brake actuator** master cylinder to the **wheel cylinders**. The **bracket, clip, and clamps** secure the front **hose** and the **tubes** to the trailer frame. The **union** connects the two **tubes** together. The **union tee** connects the two **tube assemblies** and the rear **hose** together.

The **wheel cylinders** convert hydraulic pressure to mechanical motion, activating the service brakes. The **brakeshoes** apply pressure to the **brakedrums**, slowing and stopping the trailer.

LOCATION AND CONTENT OF DATA PLATE

The following illustration shows the location and content of the data plate.

Maintain the data plate so that all information remains legible. If the plate is missing or no longer legible, notify Organizational maintenance.

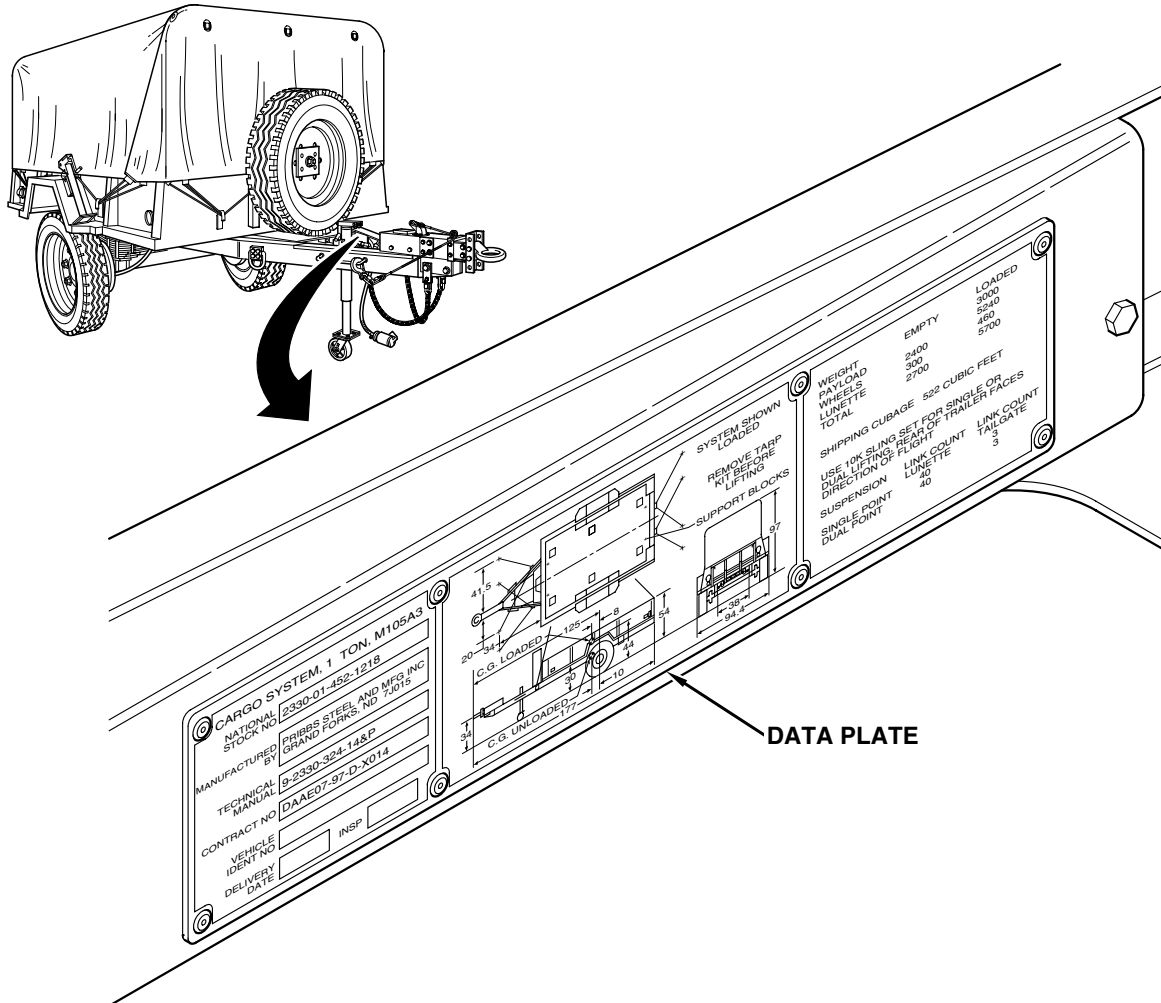

TRAILER EQUIPMENT DESCRIPTION AND DATA—Continued

0002 00

EQUIPMENT DATA

Inside Dimensions:

Height:	
To Top of Side Panels.....	18 in. (46 cm)
To Top of Stake Racks	45 in. (114 cm)
To Underside of Roof Bows.....	59 in. (150 cm)
Length:	
Body.....	108 in. (274 cm)
Width:	
Body (Between Fenders).....	65 in. (165 cm)
Body (Total Inside).....	74 in. (188 cm)

Overall Dimensions:

Height (Empty):	
To Top of Side Panels.....	54 in. (137 cm)
To Top of Tarpaulin	97 in. (246 cm)
Length.....	177 in. (450 cm)
Width.....	94.5 in. (240 cm)

Weights:

Payload Maximum:	
Cross-Country.....	3000 lb (1361 kg)
Highway.....	3000 lb (1361 kg)
Vehicle (Net)	2700 lb (1225 kg)
Total:	
Cross-Country.....	5700 lb (2586 kg)
Highway.....	5700 lb (2586 kg)

Wheels:

Manufacturer.....	Pribbs Steel & Mfg., Inc.
Number (Including Spare).....	3
Rim Size.....	7.5 x 22.5 in. (19 x 57 cm)
Number of Studs	6

TRAILER EQUIPMENT DESCRIPTION AND DATA—Continued

0002 00

EQUIPMENT DATA—Continued

Tires:

Manufacturer..... Goodyear Tire and Rubber Co.
Number (Including Spare).....3
Size..... 10R22.5

Inflation:
Highway.....70 psi (483 kPa)
Cross-Country.....70 psi (483 kPa)
Sand.....70 psi (483 kPa)

Suspension..... Multi-Leaf Springs with Auxiliary Leafs

Service Brakes:

Control..... Surge Actuator
Actuation..... Hydraulic
Manufacturer..... Pribbs Steel & Mfg., Inc.

Handbrake:

Control..... Hand
Actuation..... Mechanical

Landing Gear:

Type..... Adjustable Utility with Swivel Mount and Caster
Manufacturer..... Pribbs Steel & Mfg., Inc.

Electrical System..... 24 V dc

ELECTRICAL SYSTEM

The trailer is equipped with a 24 V dc electrical system, which receives its power from the towing vehicle through the trailer intervehicular cable assembly. The intervehicular cable assembly is connected to the trailer chassis wiring harness, which leads to the two composite lights located at the rear of the trailer and to the five running lights located at the sides and rear of the trailer.

Each composite light contains two lamps and two LEDs: one lamp functions as a taillight when the service lights are turned on, one lamp functions as both a stoplight and turn signal, one LED functions as a blackout taillight when the blackout light switch is turned on, and one LED functions as a blackout stoplight when the blackout light switch is turned on. The blackout lights automatically turn off the taillight, stoplight, and turn signals if both switches are on at the same time.

NOTE

The electrical system routing diagram is located on page 0002 00-5. The electrical schematic is located on page 0025 00-1.

HYDRAULIC SURGE BRAKE SYSTEM

The M105A3 uses a surge actuator brake system. Surge braking is accomplished by the use of an actuator located at the trailer coupler. When the towing vehicle slows down or stops, the momentum or “surge” of the trailer moving toward the towing vehicle automatically applies the brakes.

Unlike the M105A2 or earlier version trailers which used an air-over-hydraulic brakes that engaged only when the brakes from the towing vehicle were engaged, the M105A3’s brakes are applied whenever its momentum dictates. The nature of such a system results in a “live” brake action, which means that slight brake application will occur during normal towing minor disturbances to the trailer, such as bumps, hills, and curves. This braking will occur at times without any brakes being applied by the towing vehicle. This could result in higher brake temperatures.

The surge actuator also has an emergency braking breakaway system. In the event of the trailer breaking away from the towing vehicle, a breakaway cable that is connected to the towing vehicle pulls a breakaway lever on the surge actuator, which in turn engages the trailer brakes.

The major components of the hydraulic surge brake system are as follows:

1. Drawbar Coupler—attaches to the towing vehicle pintle hook. The inner casing controls the master cylinder: when the towing vehicle slows down or stops, the weight of the trailer pushes the drawbar coupler into the towing vehicle and the trailer brakes are applied; when the towing vehicle goes forward, the drawbar coupler is pulled and the trailer brakes are released. The drawbar coupler has a built-in shock absorber to prevent jerky drawbar coupler movement.
2. Master Cylinder—converts mechanical motion of the drawbar coupler and breakaway lever into hydraulic pressure. The master cylinder has an oriface and a damper that slows the rate of hydraulic pressure increase when the towing vehicle backs up. This allows the trailer to be slowly backed up for short distances on level terrain.
3. Breakaway Lever—controls the master cylinder in the event of trailer breakaway. When the breakaway lever is not engaged, the drawbar coupler controls the master cylinder.
4. Breakaway Cable—is connected to the breakaway lever and attached to the towing vehicle.
4. Hydraulic Brake Hoses and Tubes—transfer hydraulic pressure from the master cylinder to the wheel cylinder.
5. Wheel Cylinder—converts hydraulic pressure into mechanical motion. When the wheel cylinder is pressurized, it pushes the brakeshoes against the brakedrum.
6. Brakeshoes—are pushed against the brakedrum by the wheel cylinder. Brakeshoe and brakedrum friction slows and stops the trailer.

NOTE

The brake system routing diagram is located on page 0002 00-7.

**REPAIR PARTS; SPECIAL TOOLS; TEST, MEASUREMENT, AND
DIAGNOSTIC EQUIPMENT (TMDE); AND SUPPORT EQUIPMENT**

0005 00

COMMON TOOLS AND EQUIPMENT

Common tools and equipment are issued to intermediate Direct Support and intermediate General Support maintenance personnel. Common tools and equipment should not be used for purposes other than those prescribed and should be properly stored when not in use. Refer to the Modified Table of Organization and Equipment (MTOE) for authorized common tools and equipment applicable to your unit.

SPECIAL TOOLS, TMDE, AND SUPPORT EQUIPMENT

No special tools or Test, Measurement, and Diagnostic Equipment (TMDE) are required to maintain the M105A3 Trailer. Support equipment needed to operate the trailer is limited to the towing vehicle.

REPAIR PARTS

Repair parts are listed and illustrated in WPs 0062 00 through 0085 00 of this manual.

CHAPTER 2
OPERATOR INSTRUCTIONS
FOR
M105A3 CARGO TRAILER

DESCRIPTION AND USE OF CONTROLS AND INDICATORS

0006 00

GENERAL

The following pages show the location and function of the controls and indicators of the trailer. Below is an alphabetical listing of them and the page number on which they can be found. Review this section thoroughly before operating the trailer.

	<u>Page Number</u>
Brake Actuator:	
Cover.....	0006 00-4
Filler Cap.....	0006 00-4
Master Cylinder.....	0006 00-4
Two Screws.....	0006 00-4
Cargo Tiedowns	0006 00-7
Drawbar Coupler.....	0006 00-3
D-Rings.....	0006 00-7
Emergency Braking Breakaway System:	
Breakaway Cable	0006 00-5
Breakaway Lever	0006 00-5
Handbrake:	
Adjustment Knob	0006 00-6
Handbrake Lever.....	0006 00-6
Handles	0006 00-3
Intervehicular Cable Assembly.....	0006 00-3
Landing Gear:	
Caster.....	0006 00-2
Handcrank.....	0006 00-2
Release Handle.....	0006 00-2
Swivel Mount.....	0006 00-2
Safety Chains.....	0006 00-3
Spare Wheel Rack:	
Plate, Nut, Flatwasher, and Cotter Pin	0006 00-10
Stabilizer:	
Handcrank.....	0006 00-9
Lockpin.....	0006 00-9
Mounts	0006 00-9
Stowage Bracket.....	0006 00-9
Tailgate:	
Ladder.....	0006 00-8
Lockpin.....	0006 00-8
Release Handles	0006 00-8

LANDING GEAR

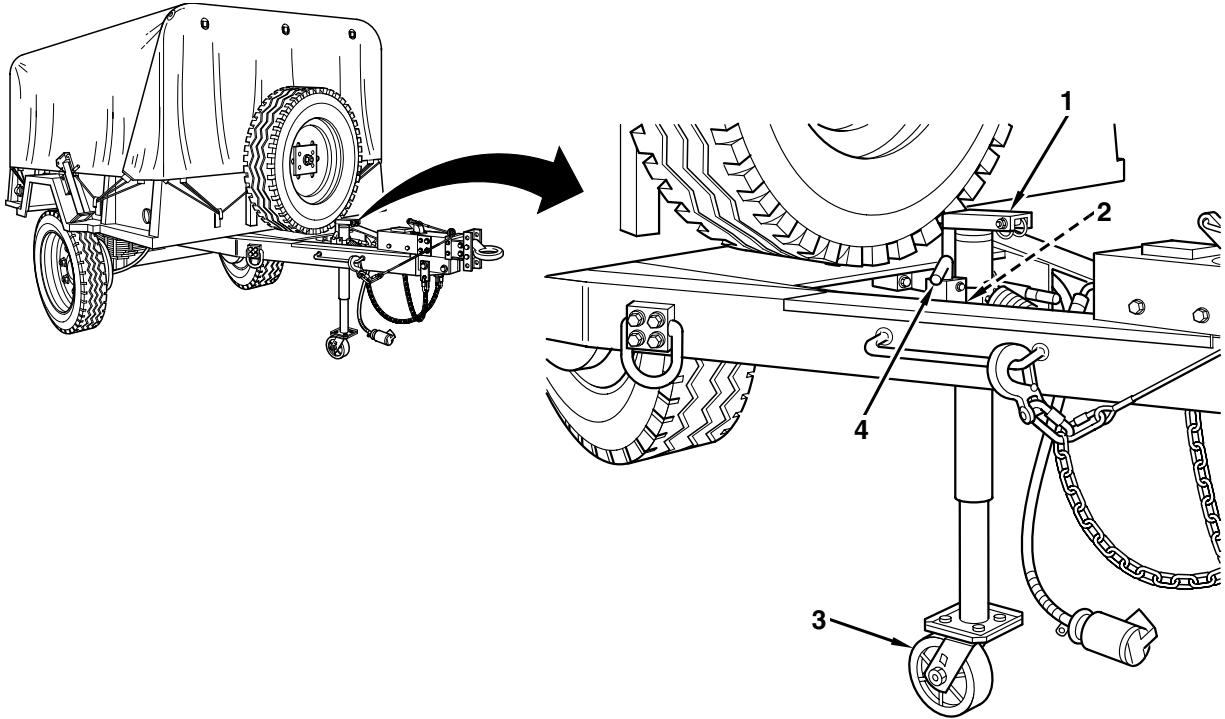

KEY	CONTROL OR INDICATOR	FUNCTION OR USE
1	Handcrank	Operates landing gear. Turn handcrank counterclockwise to extend landing gear to raise trailer tongue, and clockwise to retract landing gear to lower trailer tongue.
2	Swivel Mount	Allows landing gear to be rotated up during towing. The landing gear must be fully retracted up before storage. <u>CAUTION</u> Do not move trailer around with landing leg down. The caster is provided to allow for limited movement only to align trailer drawbar coupler to prime mover lunette for coupling purposes. Failure to follow this caution could result in damage to equipment.
3	Caster	Facilitates alignment of trailer drawbar coupler to prime mover lunette while coupling.
4	Locking Handle	Secures landing gear in down or up position.

DRAWBAR COUPLER, HANDLES, SAFETY CHAINS, AND INTERVEHICULAR CABLE ASSEMBLY

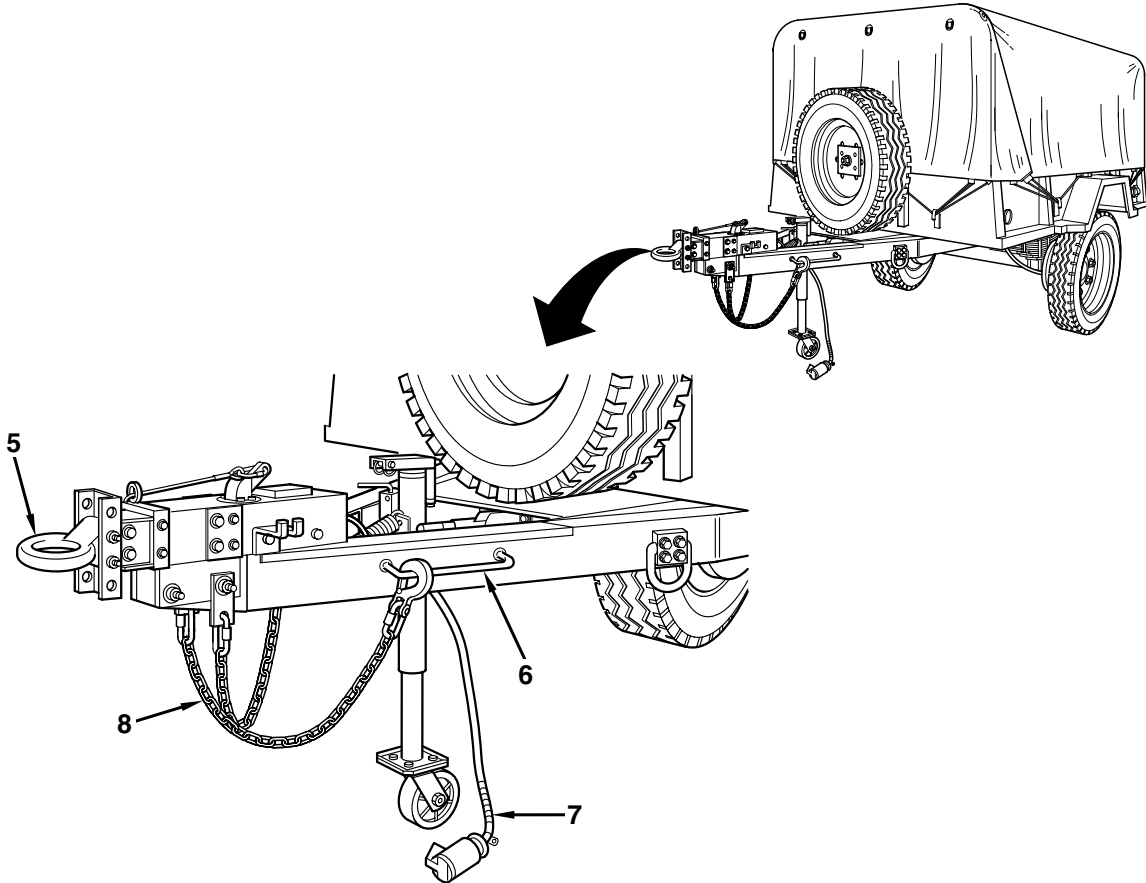

KEY	CONTROL OR INDICATOR	FUNCTION OR USE
5	Drawbar Coupler	Connects trailer to towing vehicle pintle. Also, converts trailer momentum to apply trailer brakes when towing vehicle slows down and stops.
6	Handles	Use to maneuver trailer by hand.
7	Intervehicular Cable Assembly	Connects towing vehicle and trailer electrical systems.
8	Safety Chains	Hook to eyebolts on towing vehicle to prevent trailer from fully breaking away. Safety chains should be crossed under trailer tongue when hooked to towing vehicle.

BRAKE ACTUATOR

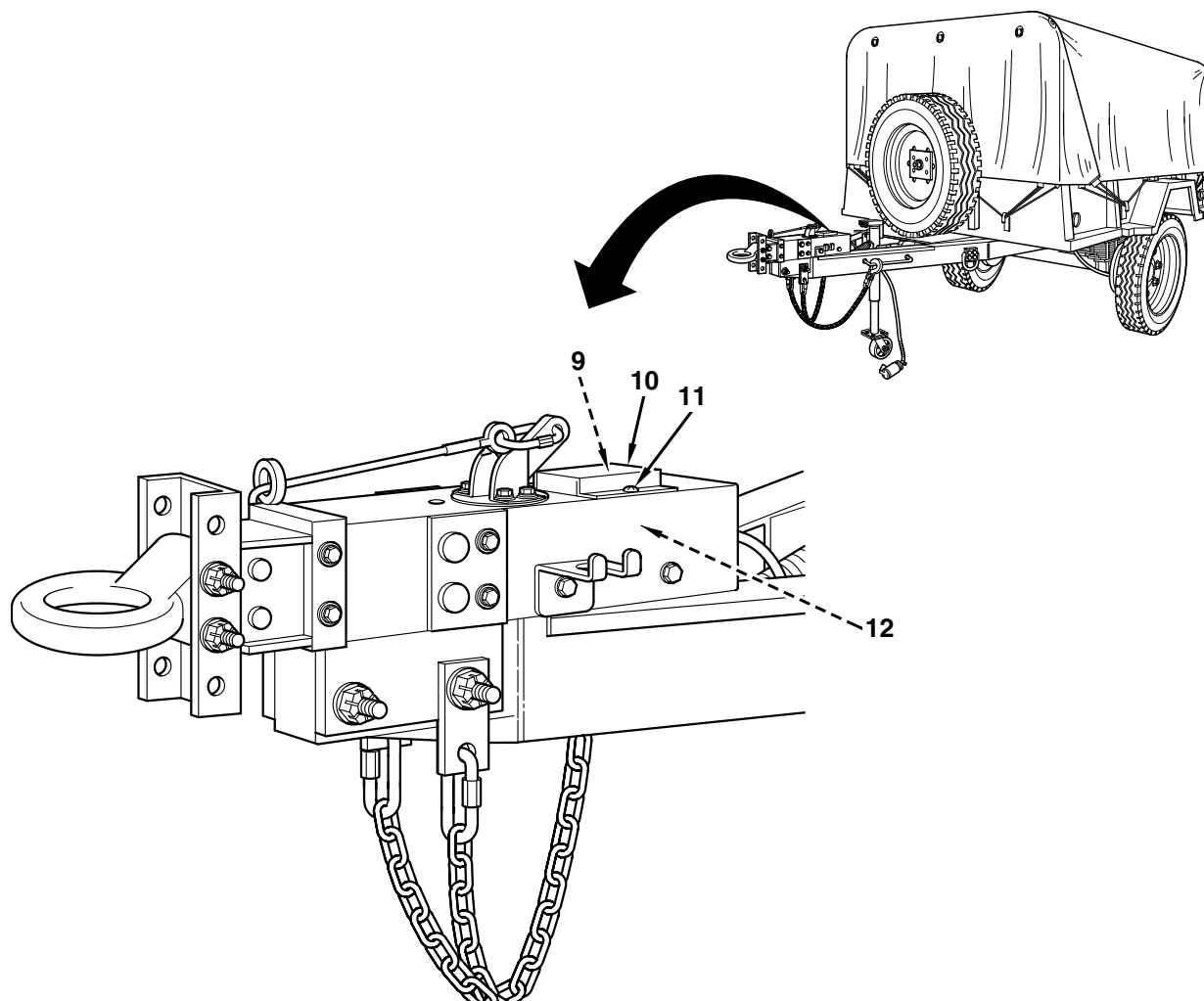

KEY	CONTROL OR INDICATOR	FUNCTION OR USE
9	Filler Cap	Remove to fill master cylinder. Filler cap should be finger-tightened only.
10	Cover	Protects filler cap from damage.
11	Two Screws	Secure cover to brake actuator outer case.
12	Master Cylinder	Converts mechanical force to hydraulic pressure to actuate brakes.

EMERGENCY BRAKING BREAKAWAY SYSTEM

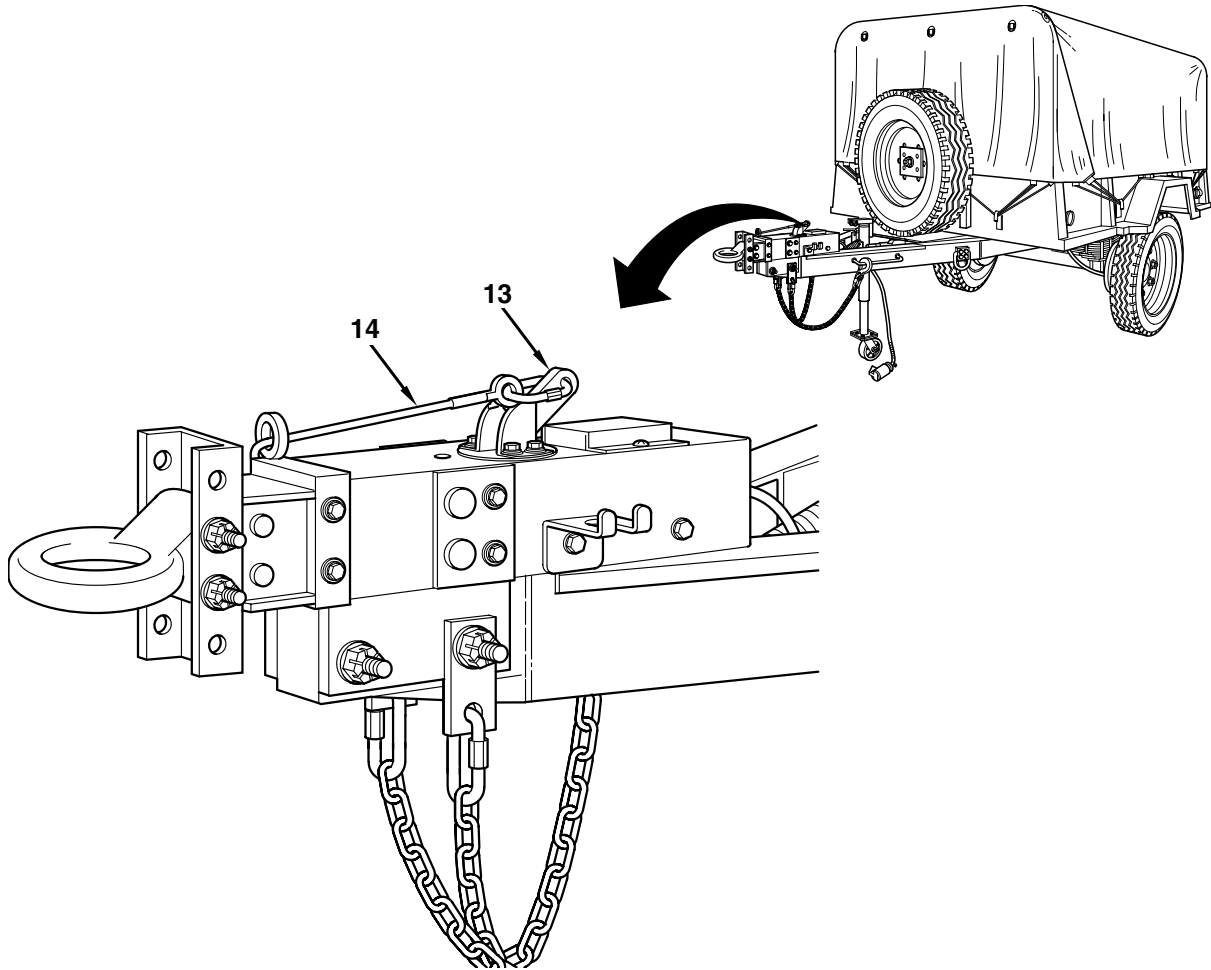

KEY	CONTROL OR INDICATOR	FUNCTION OR USE
13	Breakaway Lever	Engages trailer brakes if trailer separates from towing vehicle.
14	Breakaway Cable	Connected to safety chain and actuates breakaway lever.

HANDBRAKE

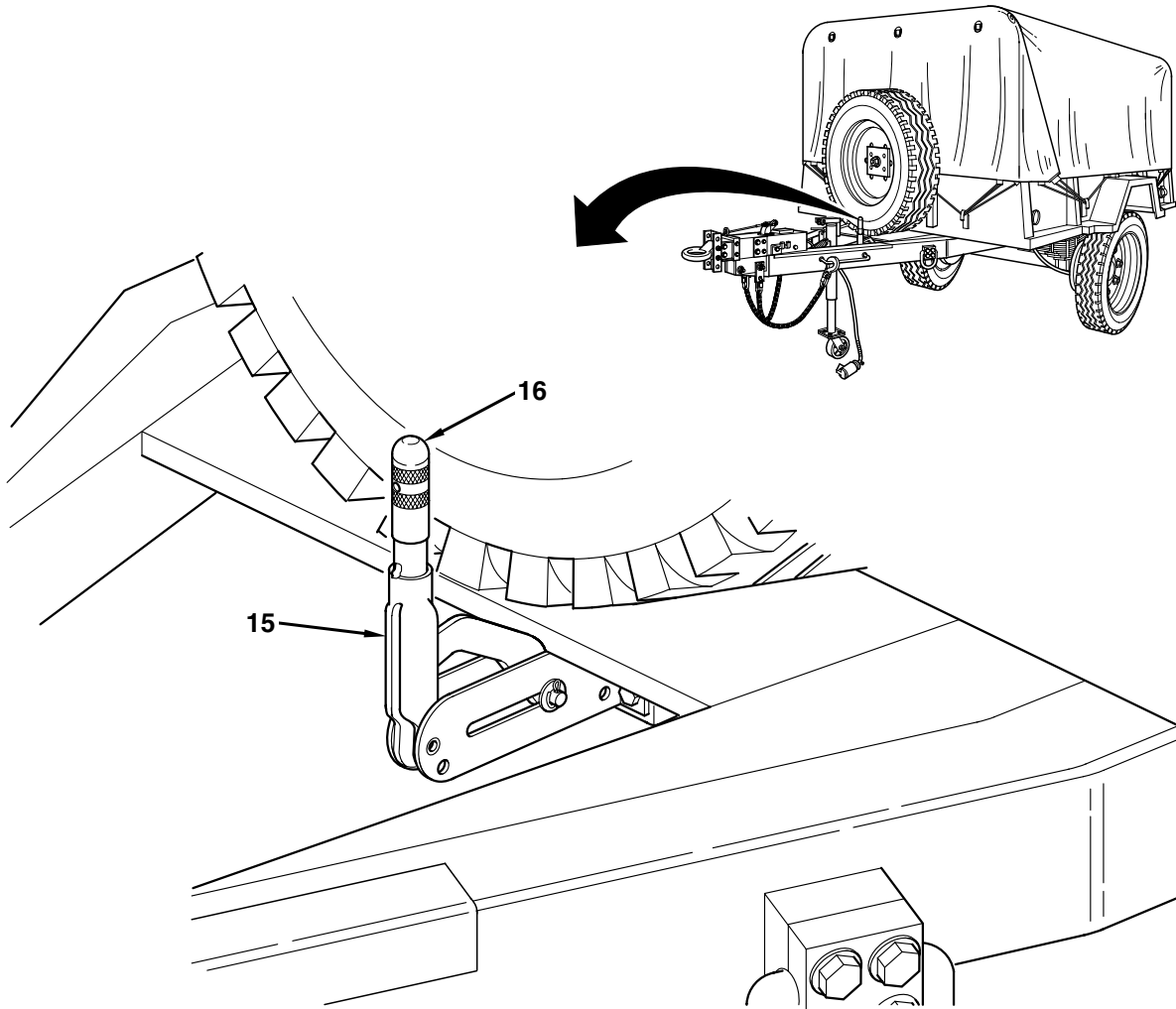

KEY	CONTROL OR INDICATOR	FUNCTION OR USE
15	Handbrake Lever	Applies handbrake. Lower handbrake lever down to horizontal position to engage handbrake.
16	Adjustment Knob	Adjusts handbrake tension. Rotate adjustment knob clockwise to increase tension, and counterclockwise to decrease tension.

D-RINGS AND CARGO TIEDOWNS

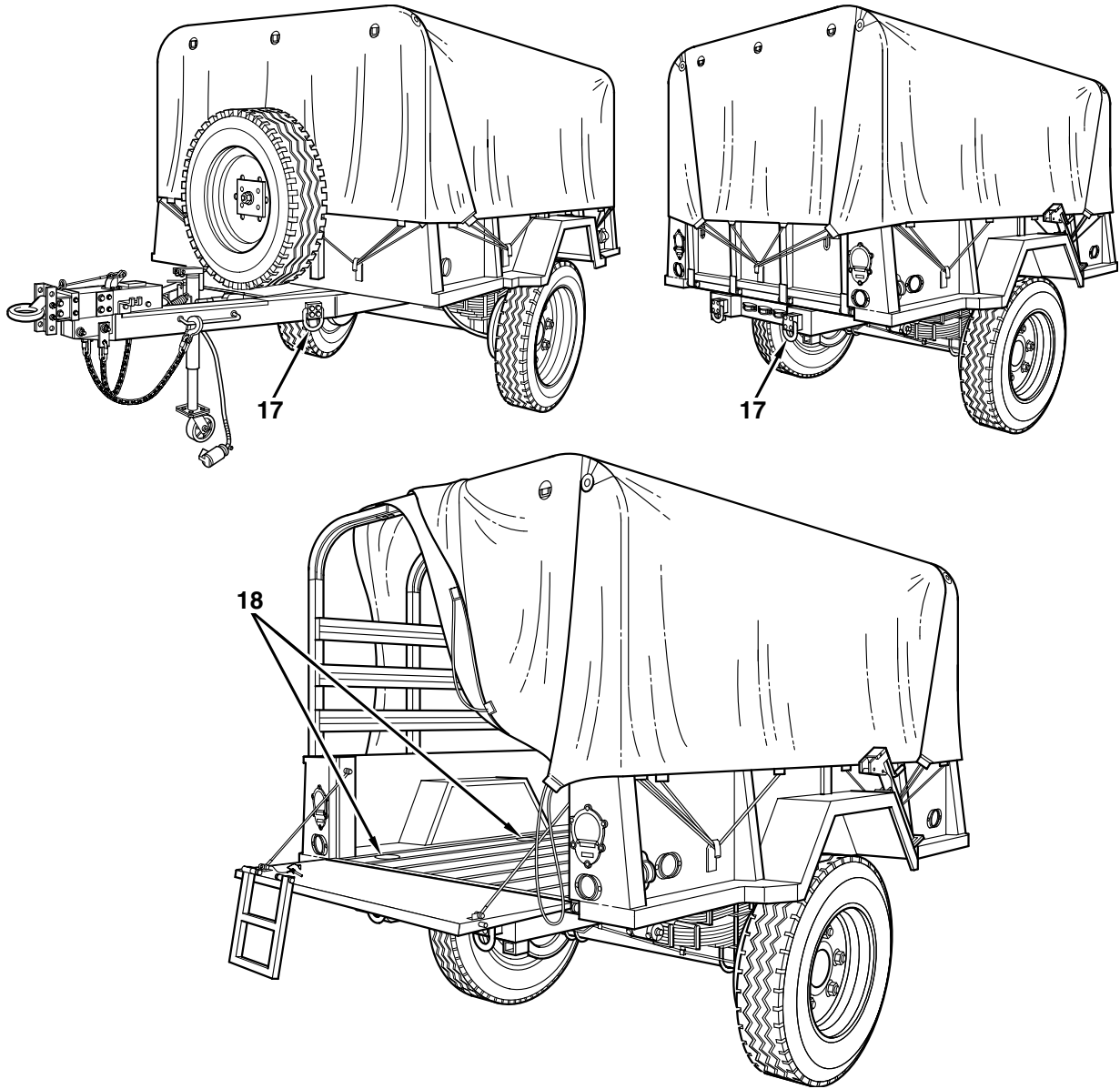

KEY	CONTROL OR INDICATOR	FUNCTION OR USE
17	D-Rings	Used to secure trailer onto transport or to lift trailer.
18	Cargo Tiedowns	Used to secure cargo inside trailer cargo body.

TAILGATE

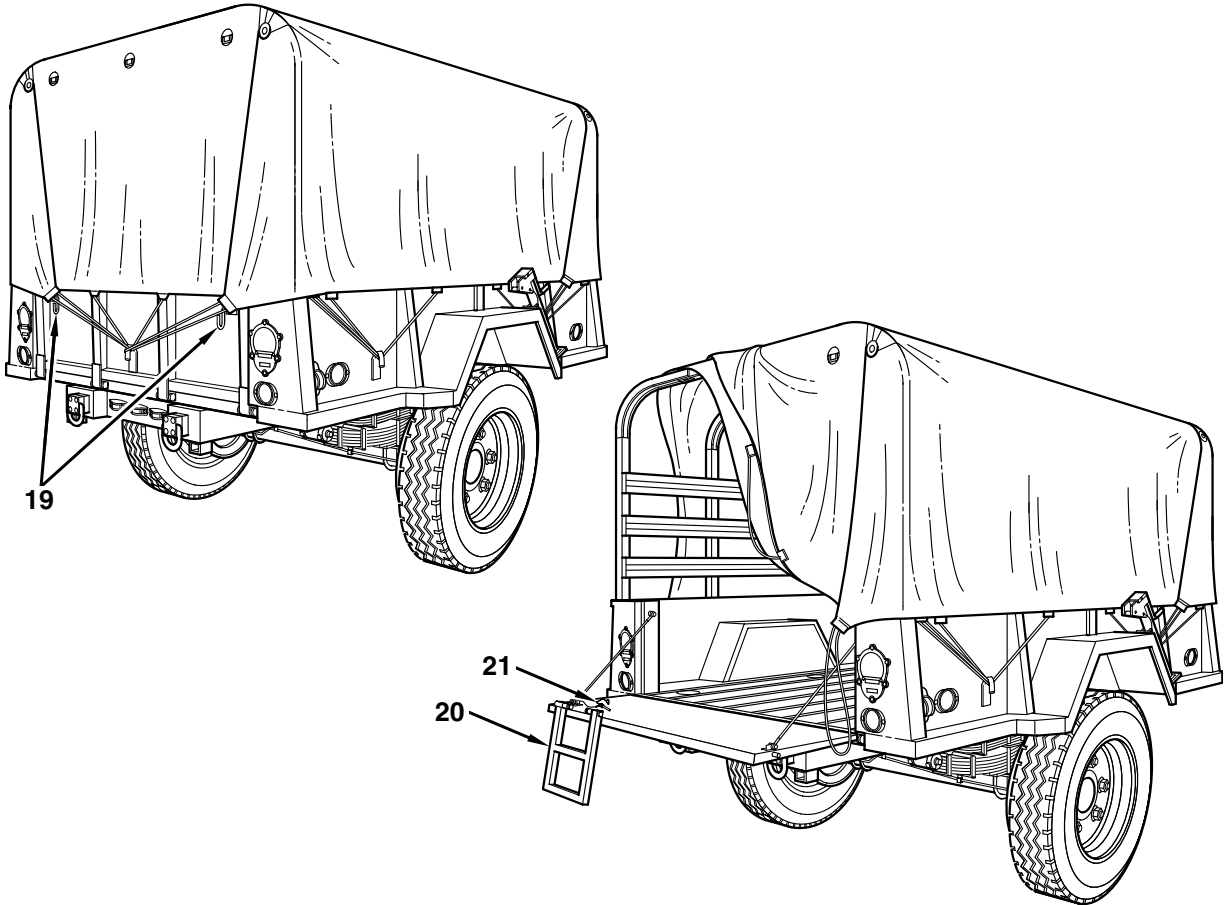

KEY	CONTROL OR INDICATOR	FUNCTION OR USE
19	Locking Handles	Secure tailgate to cargo body. Release handles are spring-loaded and can be locked in open position. To open tailgate, rotate handle 1/4 turn up, pull handle out toward center of tailgate, and rotate 1/4 turn down. This locks handle in open position. Repeat for other side. To close tailgate, ensure that both handles are locked in open position. Close tailgate and rotate handle 1/4 turn up. Spring pressure of handle will secure tailgate once pin of handle lines up with hole in body. Repeat for other side.
20	Ladder	Swings down when tailgate is open.
21	Lockpin	Secures ladder to inside of tailgate when ladder is not in use. Ladder should be secured when tailgate is closed.

STABILIZER

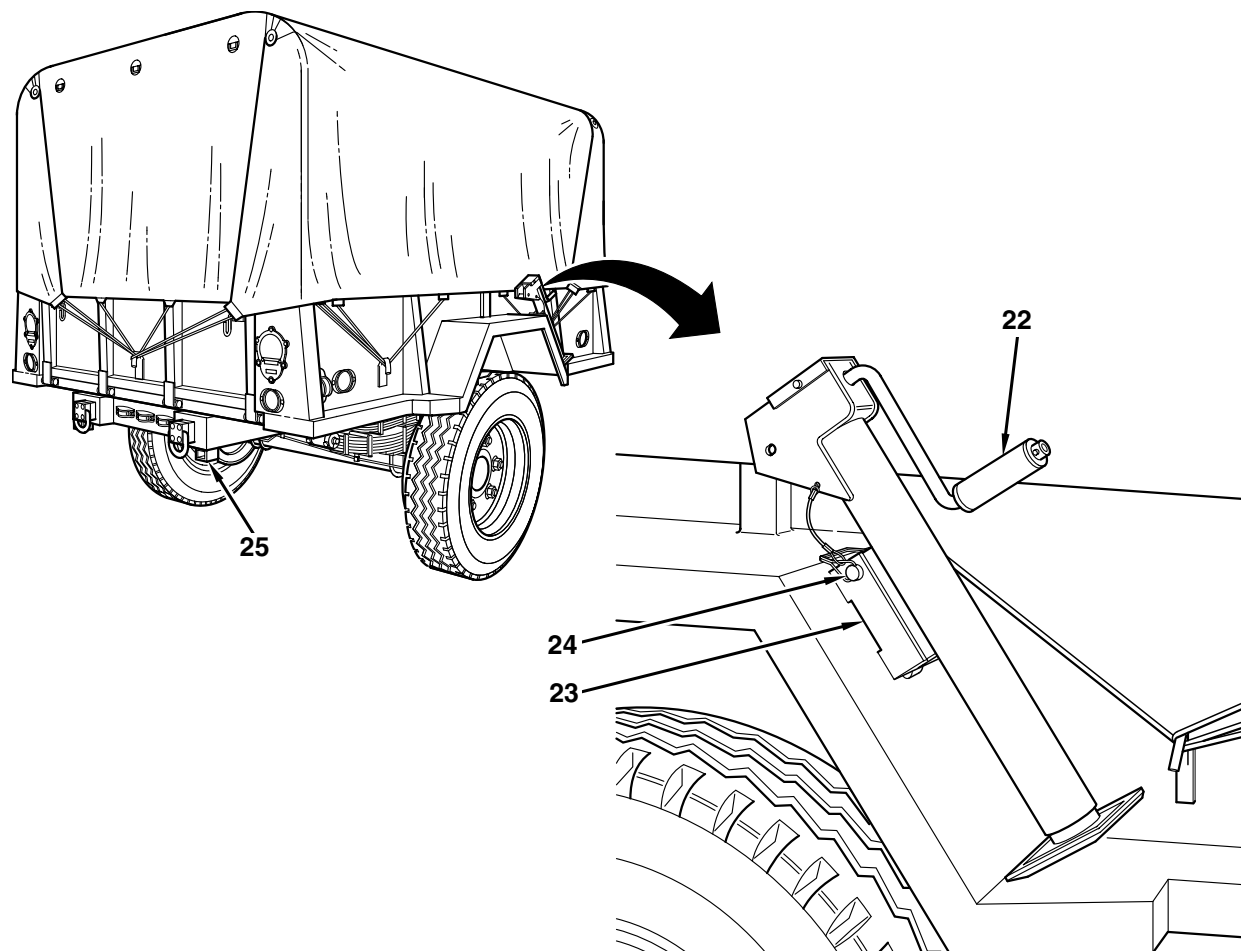

KEY	CONTROL OR INDICATOR	FUNCTION OR USE
22	Handcrank	Operates stabilizer. Turn handcrank counterclockwise to extend stabilizer to raise trailer side, and clockwise to retract stabilizer to lower trailer side.
23	Stowage Bracket	Secures stabilizer in cargo body for stowage.
24	Lockpin	Locks stabilizer to stowage bracket or to either mount.
25	Stabilizer Mounts	Secure stabilizer to trailer using lockpin.

SPARE WHEEL RACK

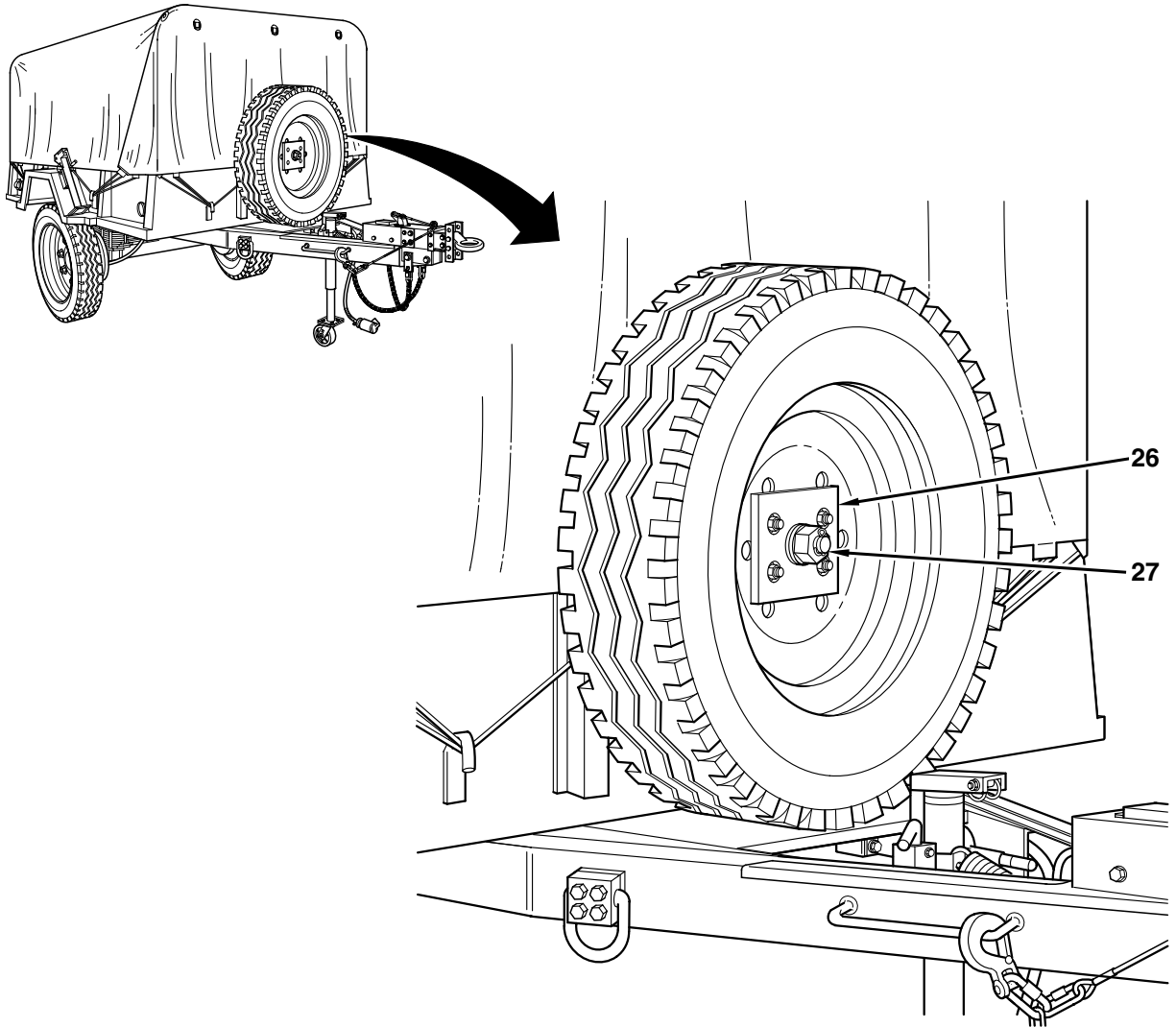

KEY	CONTROL OR INDICATOR	FUNCTION OR USE
26	Plate	Secures spare wheel in stowed position on trailer.
27	Cotter Pin, Nut, and Flatwasher	Secure plate that holds spare wheel in stowed position.

OPERATION UNDER USUAL CONDITIONS

0007 00

GENERAL

This WP contains instructions for safely operating the trailer under usual conditions. Operating the trailer under unusual operating conditions is described in WP 0008 00.

Perform all "Before" Operator/Crew Preventive Maintenance Checks and Services (PMCS) before operating the trailer (WP 0017 00).

Review all towing vehicle operating instructions to prepare for coupling and uncoupling operations.

COUPLING TRAILER TO TOWING VEHICLE**WARNING**

- All personnel must stand clear of towing vehicle and trailer during coupling operation. Failure to follow this warning may result in serious injury or death.
 - Drawbar is heavy—up to 400 lb (181 kg) loaded tongue weight. Do not attempt to lift drawbar. Use landing gear to raise and lower drawbar. Failure to follow this warning may result in serious injury or death.
1. Prepare towing vehicle for coupling and operation in accordance with applicable manual.
 2. Apply trailer handbrake by lowering handbrake lever (1) down to horizontal position.

CAUTION

Have assistant direct you during backing operation. Do not back prime mover into trailer. Failure to follow this caution may result in damage to equipment.

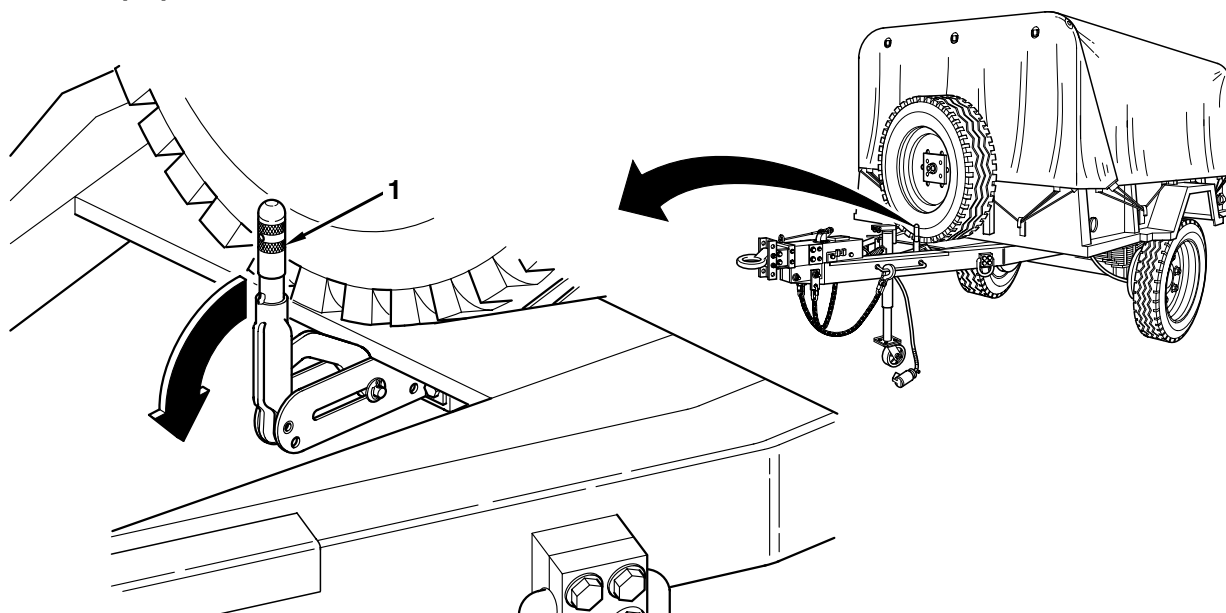

COUPLING TRAILER TO TOWING VEHICLE—Continued

CAUTION

Do not back towing vehicle into trailer. Failure to follow this caution may result in damage to landing gear.

3. Align towing vehicle with trailer and slowly back towing vehicle until towing vehicle pintle (4) is adjacent to trailer drawbar coupler (8).
4. Remove pintle lockpin (7) and open pintle (4).
5. Release trailer handbrake and, with assistance, move trailer as required to engage drawbar coupler (8) in pintle (4).
6. Close pintle (4) and install towing lockpin (7).
- 7.

NOTE

If the hooks on the safety chains (9) do not fit on the towing vehicle eyebolts (6), connect to the area of the eyebolts closer to the vehicle where its diameter is less.

7. Cross safety chains (9) under drawbar coupler (8) and attach to towing vehicle eyebolts (6).

WARNING

Do not disconnect breakaway chain from safety chain or breakaway lever. This ensures that, in event of trailer breakaway, the emergency braking system engages. Failure to follow this warning could result in serious injury or death to personnel or damage to equipment.

8. Connect intervehicular cable assembly (2) to towing vehicle receptacle (3).

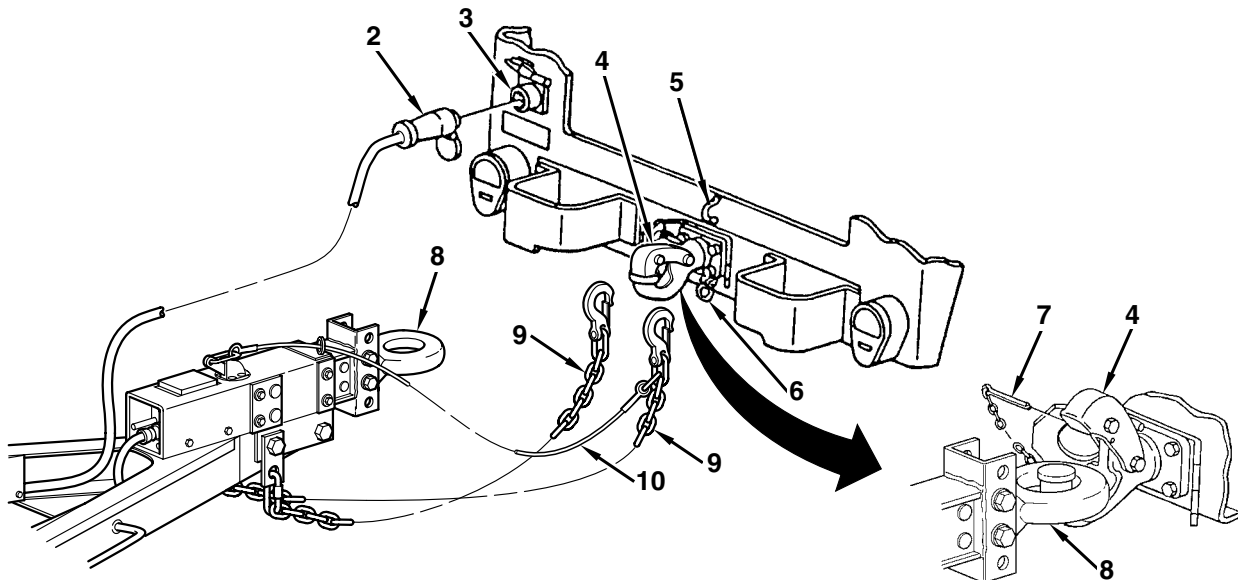

COUPLING TRAILER TO TOWING VEHICLE—Continued

9. Turn handcrank (11) clockwise to retract landing gear (12) up completely.
10. Pull up on locking handle (13) and rotate landing gear (12) up. Let go of locking handle making sure that pin engages completely.

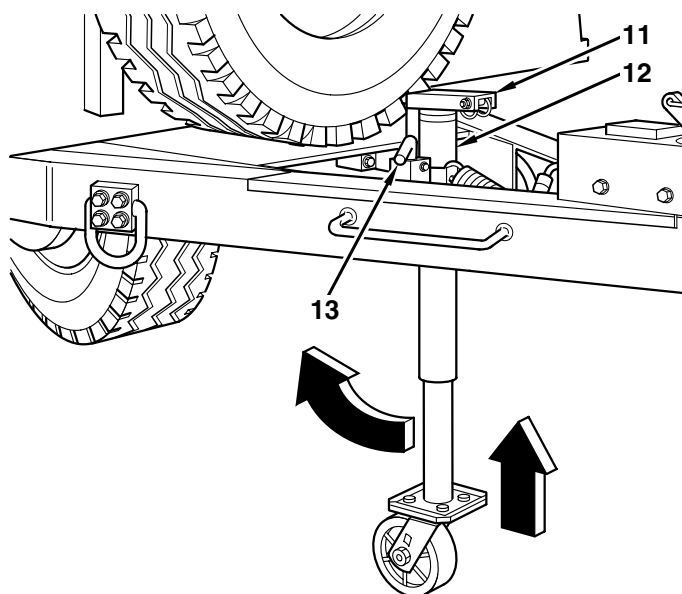

TOWING TRAILER

WARNING

Before moving trailer, ensure that all loose equipment is properly stowed and that nothing will drag on ground. If trailer is loaded, ensure that load is properly secured. Ensure landing gear is rotated up and locked in transport position. Ensure parking brake is disengaged. Failure to follow this warning may result in injury to personnel or damage to equipment.

NOTE

Limited braking often occurs during backup but does not interfere with maneuvering trailer. Operator should back up slowly and steadily to avoid jamming. Do not lurch.

1. Perform all “During” Operator/Crew PMCS while operating the trailer (WP 0017 00).
2. When towing, overall length of trailer must be kept in mind when passing other vehicles and when turning.
3. Turning and backing operations will be affected because towing vehicle and trailer are a hinged unit.
4. Always tow trailer at safe speeds and note any driving irregularities.

TOWING TRAILER—Continued

5. When parking for extended periods, set handbrakes on both towing vehicle and trailer.
6. If towing vehicle and trailer are parked on a hill, chock wheels.
7. Refer to FM 21-305 for further information on proper driving practices.

UNCOUPLING TRAILER FROM TOWING VEHICLE

WARNING

- All personnel must stand clear of towing vehicle and trailer during uncoupling operation. Failure to follow this warning may result in serious injury or death.
- Drawbar is heavy—up to 400 lb (181 kg) loaded tongue weight. Do not attempt to lift drawbar. Use landing gear to raise and lower drawbar. Failure to follow this warning may result in serious injury or death.

1. Pull up locking handle (13) and rotate landing gear (12) down. Release locking handle.
2. Turn handcrank (11) counterclockwise until caster (14) makes contact with ground. Turn handcrank as required to take trailer drawbar coupler weight off of towing vehicle pintle.

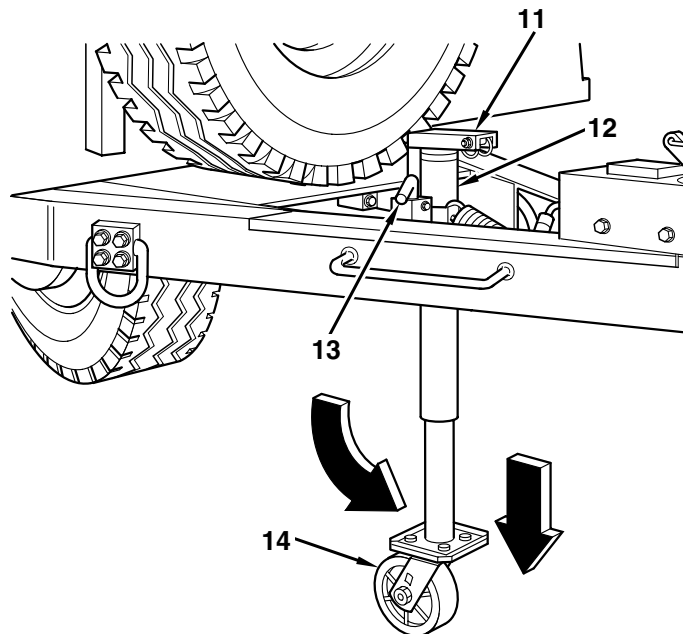

UNCOUPLING TRAILER FROM TOWING VEHICLE—Continued

3. Disconnect intervehicular cable assembly (2) from towing vehicle receptacle (3).

NOTE

Do not disconnect breakaway chain (10).

4. Disconnect safety chains (9) from towing vehicle eyebolts (6).
5. Remove pintle lockpin (7) and open pintle (4).
6. With assistance, move trailer as required to disengage drawbar coupler (8) from pintle (4).

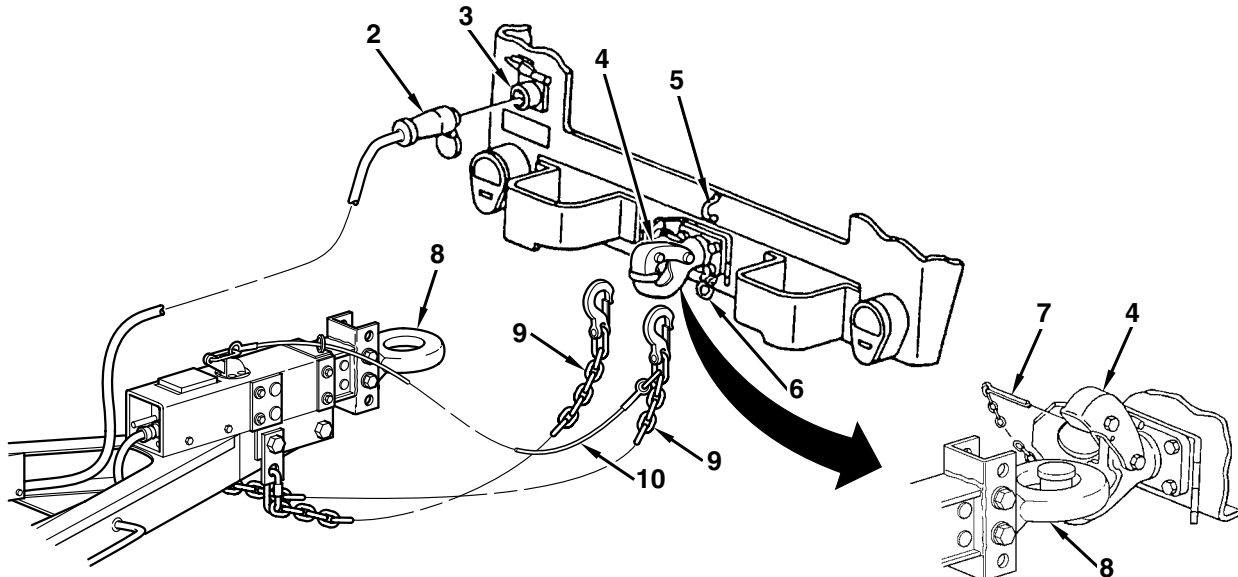

UNCOUPLING TRAILER FROM TOWING VEHICLE—Continued

7. Apply trailer handbrake by lowering handbrake lever (1) down to horizontal position.
8. Move towing vehicle a safe distance from trailer.
9. Perform all “After” Operator/Crew PMCS (WP 0017 00).

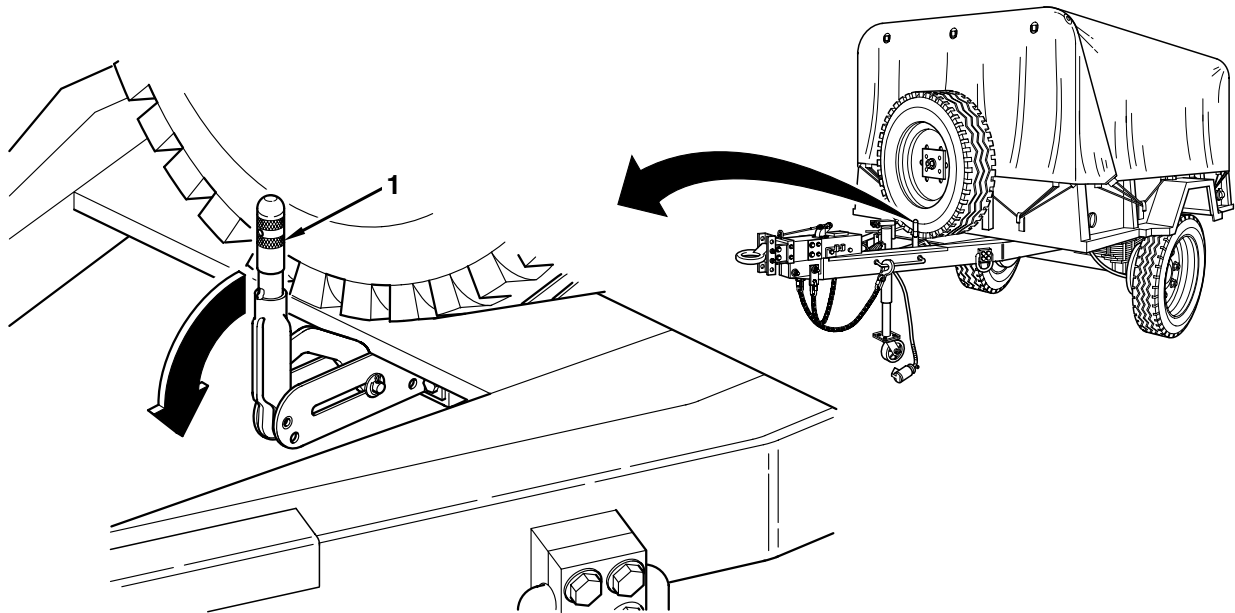

LOADING TRAILER

WARNING

If trailer is not connected to towing vehicle, use rear jack when loading heavy loads. Failure to follow this warning may result in trailer tipping backward causing serious injury or death.

1. Load capacity of trailer is 3000 lb (1361 kg) on highway or cross-country. Do not exceed load capacity.
2. All loads must be evenly distributed over trailer floor. Loads should be secured using all six cargo tiedowns if possible. Nylon straps should be used at each location to apply even pressure at each point.
3. Trailer may be loaded with a forklift truck if tailgate is opened.

HELICOPTER SLING LOADING TRAILER

For sling loading the trailer with a helicopter, refer to FM 10-450-4 or FM 10-450-5.

OPERATION UNDER UNUSUAL CONDITIONS

0008 00

GENERAL

This WP contains instructions for safely operating the trailer under unusual conditions.

In addition to normal preventive maintenance service, special care in cleaning and lubrication must be observed where extreme temperature, humidity, and terrain conditions are present or anticipated. Proper cleaning, lubrication, storage, and handling of fuels and lubricants not only ensure proper operation and functioning, but also guard against excessive wear in the working parts and deterioration of materials.

FM 55-30 contains instructions on driver selection, training, and supervision. FM 21-305 prescribes special driving instructions for operating wheeled vehicles under unusual conditions. A detailed study of these manuals is essential for the use of this trailer under unusual conditions.

When chronic failure of the trailer results from exposure to extreme conditions, report the condition on SF 368.

OPERATION IN EXTREME COLD

CAUTION

To ensure equipment is not damaged, approved practices and precautions must be followed.

1. Extensive preparation of materials scheduled for operation in cold is necessary. Generally, extreme cold causes lubricants to thicken or congeal, cracks insulation causing electrical short circuits, and causes various construction materials to become hard, brittle, and easily damaged or broken.
2. Operator must always be on alert for indications of the effect of cold weather on trailer.
3. Use caution when placing vehicle in motion after a shutdown. Congealed lubricants may cause failure of parts. Tires frozen to the ground or frozen to shape of flat spot while under-inflated must be considered. One or more brakeshoes may be frozen fast and require preheating to avoid damage to towing vehicle clutch surfaces.
4. Refer to WP 0018 00 for proper lubrication during extreme cold weather.
5. Refer to FM 9-207 for description of operations in extreme cold.
6. Immediately after each operation, remove snow, ice, and/or mud, thoroughly clean, inspect, and lubricate trailer if tactical situation permits. Upon completion of this operation, refer to WP 0017 00, Table 1 (Operator/Crew PMCS), for "After" procedures to be performed.
7. At halt or parking:
 - a. When halted for a short shutdown period, park trailer in a sheltered spot out of wind. If no shelter is available, park so rear of trailer faces into wind. For long shutdowns, if high and dry ground is not available, prepare a footing of planks or brush.
 - b. Immediately after each operation, remove snow, ice, and/or mud, thoroughly clean and inspect trailer if tactical situation permits. Upon completion of this operation, refer to WP 0017 00, Table 1 (Operator/Crew PMCS), for "After" procedures to be performed.

OPERATION IN EXTREME COLD—Continued

- c. Gage tires for correct pressure:
 - Highway.....70 psi (483 kPa)
 - Cross-Country.....70 psi (483 kPa)
 - Sand.....70 psi (483 kPa)

OPERATION IN EXTREME HEAT

1. Refer to WP 0018 00 for proper lubrication during extreme heat conditions. Adequate lubrication is essential. Extreme heat will cause oil films to evaporate, resulting in inadequate lubrication.
2. Keep tires protected from direct sunlight to prevent increases in air pressure and deterioration of rubber.
3. Cover inactive trailer with tarpaulins, if they are available and there is no other shelter. Shake out and air for several hours weekly canvas covers or other items subject to deterioration from mildew or attacks by insects or vermin.
4. Protect trailer from direct rainfall, if possible.
5. Dampness increases corrosive action. Inspect painted surfaces and electrical connections more frequently for damage.

OPERATION IN SANDY OR DUSTY AREAS

1. Clean, inspect, and lubricate trailer frequently when operating in dusty or sandy areas. Refer to WP 0018 00 for proper lubrication instructions.
2. Maintain proper tire pressure. Tire pressure is the same for highway, cross-country, and sandy areas (WP 0002 00). Make sure no dust or sand enters exposed mechanisms or lubrication fittings during inspections and repair operations. Cover exposed parts with tarpaulin or other suitable cover during disassembly and assembly.
3. When beginning operations in dusty or sandy areas, remove lubricants from exposed components (such as landing gear), if tactical situation permits. Grease and oil will cause dust and sand to accumulate and act as an abrasive, causing rapid wear.

OPERATION IN SALTWATER AREAS

1. Clean, inspect, and lubricate trailer as necessary when operating in saltwater areas (WP 0018 00). Wash salt deposits from all equipment with fresh water. Observe the precautions in operation under humid conditions.
2. Moist and salty areas can destroy rust preventative qualities of oils and greases. When equipment is active, exposed surfaces should be cleaned and lubricated daily. Refer to WP 0018 00 for proper lubrication instructions.
3. When equipment is inactive, unpainted parts should be coated with lubrication oil (Item 7, WP 0060 00). All covers and caps should be in place.

OPERATION IN MUD AND SNOW

1. After each operation, remove snow, ice, and/or mud from underneath trailer, brake actuator, hoses, lines, tubes, and electrical connections.
2. Refer to FM 21-305 for special instructions on driving hazards in snow.

OPERATION IN MUD AND SNOW—Continued

3. Immediately after operation in mud, thoroughly clean and inspect if tactical situation permits.

FORDING

1. Instructions for fording operations for towing vehicle also apply to trailer.
2. Deleted.
3. Fording depth of trailer is limited to fording depth limit of cargo or towing vehicle, whichever is lower.
4. After fording operations, perform following services immediately, if tactical situation permits:

WARNING

Solvents can burn easily, can give off harmful vapors, and are harmful to skin and clothing. To avoid injury or death, keep away from open fire and use in a well-ventilated area. If solvent gets on skin or clothing, wash immediately with soap and water.

- a. Notify Organizational maintenance to remove wheel and rim assemblies and clean them thoroughly with cleaning compound (Item 10, WP 0060 00). Dry all working components of brakes and wheel bearings. Lubricate in accordance with WP 0023 00.
 - b. Immersion in salt water greatly increases rusting and corrosion, especially on unpainted surfaces. Remove all traces of saltwater from trailer. Apply lubricating oil (Item 7, WP 0060 00). Notify Organizational maintenance that complete disassembly/assembly may be needed.
5. Notify Organizational maintenance to clean wheel bearings and hand pack with lubricant specified in WP 0023 00 after each submersion.

CHAPTER 3
OPERATOR TROUBLESHOOTING PROCEDURES
FOR
M105A3 CARGO TRAILER

INTRODUCTION0009 00

GENERAL

This WP provides information on the malfunction/symptom index and procedures of Operator troubleshooting.

MALFUNCTION/SYMPTOM INDEX (WP 0010 00)

The Malfunction/Symptom Index is a quick reference index for finding troubleshooting procedures. Associated with each symptom name is a WP sequence number representing the starting point in a troubleshooting sequence.

TROUBLESHOOTING PROCEDURES (WPs 0011 00 and 0012 00)

The troubleshooting WPs contain tables listing the malfunctions, tests or inspections, and corrective actions required to return the trailer to normal operation. Perform the steps in the order they appear in the tables.

The columns are defined as follows:

1. **MALFUNCTION**—A visual or operational indication that something is wrong with the trailer.
2. **TEST OR INSPECTION**—A procedure to isolate the problem in a component or system.
3. **CORRECTIVE ACTION**—A procedure to correct the problem.

If you are unsure of the location of an item mentioned in troubleshooting, refer to WP 0002 00 or to the maintenance task where the item is replaced.

Before performing troubleshooting, read and follow all safety instructions found in the warning summary at the front of this manual.

This manual cannot list all malfunctions that may occur, nor all tests or inspections and corrective actions. If a malfunction is not listed, or is not corrected by the listed corrective actions, notify your supervisor.

MALFUNCTION/SYSTEM INDEX

0010 00

GENERAL

This malfunction/symptom index is provided as a quick way to get you to the part of troubleshooting that will help you solve the problem you are having. It lists all of the malfunctions covered in Operator troubleshooting.

ELECTRICAL SYSTEM

- 1. All lamps/LEDs fail to light..... WP 0011 00
- 2. One or more lamps/LEDs (but not all) fail to light..... WP 0011 00

BRAKES

- 1. Brakes do not engage..... WP 0012 00
- 2. Brakes grab..... WP 0012 00
- 3. Brakes do not release WP 0012 00

ELECTRICAL SYSTEM OPERATOR/CREW TROUBLESHOOTING

0011 00

THIS WP COVERS:

Electrical Troubleshooting

INITIAL SETUP:

Maintenance Level

Operator/Crew

References

Towing Vehicle Operator's Manual

WP 0029 00

To troubleshoot the trailer's 24 V dc electrical system, perform the tests/inspections and corrective actions provided in Table 1.

WARNING

Make sure all electrical power is disconnected before performing any maintenance on electrical system. Serious injury or death may result if proper precautions are not taken.

NOTE

For corrective actions or malfunctions not listed in Table 1, notify Organizational maintenance.

Table 1. Troubleshooting Procedures.

MALFUNCTION	TEST OR INSPECTION	CORRECTIVE ACTION
<p>1. ALL LAMPS/LEDs FAIL TO LIGHT</p>	<p>1. Check light switch on towing vehicle.</p> <p>2. Check intervehicular cable assembly for proper connection.</p> <p>3. Inspect for dirty or corroded sockets on intervehicular cable. Check for damaged pins.</p>	<p>1. Place light switch on towing vehicle in proper mode of operation. If towing vehicle lamps light but trailer lights do not, proceed to step 2.</p> <p>1. If cable is not properly connected, reconnect cable. If cable is properly connected, proceed to step 3.</p> <p>1. If pins or socket are dirty or corroded, clean pins, socket, and plug. If pins are damaged, notify Organizational maintenance.</p>

Table 1. Troubleshooting Procedures—Continued.

MALFUNCTION	TEST OR INSPECTION	CORRECTIVE ACTION
1. ALL LAMPS/LEDs FAIL TO LIGHT—Continued	4. Check for good ground connection at intervehicular cable. 5. Check towing vehicle circuit breaker/fuse. 6. Tighten bolts that mount light to trailer.	1. Have ground connection tightened. 1. Refer to towing vehicle operator’s manual for instructions.
1. ONE OR MORE LAMPS/LEDs (BUT NOT ALL) FAIL TO LIGHT	1. Check for burned out or defective lamps/LEDs. 2. Check for broken lead wires or loose connections. 3. Check lens and light assembly for damage. 4. Check for dirty or corroded connections	1. If lamps/LEDs are burned out or defective, notify Organizational maintenance. If lamps/LEDs are not burned out or defective, proceed to step 2. 1. If connections are loose, tighten connections. If lead wires are broken, notify Organizational maintenance. 1. If lens and light assembly is not damaged, proceed to step 4. 1. Clean connections if dirty or corroded. If above steps do not correct malfunction, notify Organizational maintenance.

END OF TASK

BRAKE SYSTEM OPERATOR/CREW TROUBLESHOOTING

0012 00

THIS WP COVERS:
Brakes Troubleshooting

INITIAL SETUP:
Maintenance Level
Operator/Crew

To troubleshoot the trailer's brakes, perform the tests/inspections and corrective actions provided in Table 1.

Table 1. Troubleshooting Procedures.

MALFUNCTION	TEST OR INSPECTION	CORRECTIVE ACTION
1. BRAKES DO NOT ENGAGE	1. Inspect hoses, tubes, connectors, and union tee for leaks. 2. Check for dirt, mud, or other foreign material inside brake actuator casing.	1. If brake fluid is leaking, notify Organizational maintenance. 1. Clean out dirt, mud, and foreign material inside brake actuator casing.
2. BRAKES GRAB		1. Notify Organizational maintenance.
3. BRAKES DO NOT RELEASE	1. Check if handbrake is engaged. 2. Check if emergency braking breakaway lever is in the up or activated position.	1. Release handbrake. 2. If handbrake is not engaged, notify Organizational maintenance. 1. Notify Organizational maintenance.

END OF TASK

CHAPTER 4
ORGANIZATIONAL TROUBLESHOOTING PROCEDURES
FOR
M105A3 CARGO TRAILER

INTRODUCTION

0013 00

GENERAL

This WP provides information on the malfunction/symptom index and the procedures for Organizational troubleshooting.

MALFUNCTION/SYMPTOM INDEX (WP 0014 00)

The malfunction/symptom index is a quick reference index for finding troubleshooting procedures. Associated with each symptom name is a WP sequence number representing the starting point in a troubleshooting sequence.

TROUBLESHOOTING PROCEDURES (WPs 0015 00 and 0016 00)

The troubleshooting WPs contain tables listing the malfunctions, tests or inspections, and corrective actions required to return the trailer to normal operation. Perform the steps in the order they appear in the tables.

The columns are defined as follows:

1. **MALFUNCTION**—A visual or operational indication that something is wrong with the trailer.
2. **TEST OR INSPECTION**—A procedure to isolate the problem in a component or system.
3. **CORRECTIVE ACTION**—A procedure to correct the problem.

If you are unsure of the location of an item mentioned in troubleshooting, refer to WP 0002 00 or to the maintenance task where the item is replaced.

Before performing troubleshooting, read and follow all safety instructions found in the warning summary at the front of this manual.

This manual cannot list all malfunctions that may occur, nor all tests or inspections and corrective actions. If a malfunction is not listed, or is not corrected by the listed corrective actions, notify your supervisor.

MALFUNCTION/SYSTEM INDEX

0014 00

GENERAL

This malfunction/symptom index is provided as a quick way to get you to the part of troubleshooting that will help you solve the problem you are having. It lists all of the malfunctions covered in Organizational troubleshooting.

ELECTRICAL SYSTEM

- 1. All lamps/LEDs dim or flickering..... WP 0015 00
- 2. One or more lamps/LEDs (but not all) fail to light..... WP 0015 00

BRAKES

- 1. Brakes do not engage..... WP 0016 00
- 2. Brakes grab..... WP 0016 00
- 3. Brakes do not release WP 0016 00

ELECTRICAL SYSTEM ORGANIZATIONAL TROUBLESHOOTING

0015 00

THIS WP COVERS:

Electrical Troubleshooting

INITIAL SETUP:

Maintenance Level

Organizational

Tools and Special Tools

Multimeter

Tool Kit, General Mechanic's

References

Towing Vehicle Organizational Maintenance Manual

WP 0002 00

WP 0027 00

WP 0025 00

WP 0028 00

WP 0026 00

WP 0029 00

To troubleshoot the trailer's 24 V dc electrical system, perform the tests/inspections and corrective actions provided in Table 1.

Table 1. Troubleshooting Procedures.

MALFUNCTION	TEST OR INSPECTION	CORRECTIVE ACTION
<p>1. ALL LAMPS/LEDs DIM OR FLICKERING</p>	<p style="text-align: center;"><u>WARNING</u></p> <p>When performing steps 1 and 2 in "TEST OR INSPECTION" column, disconnect intervehicular cable assembly from towing vehicle. Failure to follow this warning may result in injury or death due to electric shock.</p> <p style="text-align: center;">NOTE</p> <p>Refer to page 0002 00-5 for routing of electrical wires and location of electrical components and page 0025 00-1 for electrical schematic.</p> <p>1. Check continuity between terminal ground wire 90 and frame.</p> <p>2. Check continuity between terminal ground wire 90 and socket of intervehicular cable assembly plug.</p>	<p>1. If there is no continuity, remove and clean mating surfaces (WP 0029 00).</p> <p>1. If there is no continuity, replace intervehicular cable assembly (WP 0029 00).</p>

ELECTRICAL SYSTEM ORGANIZATIONAL TROUBLESHOOTING—Continued 0015 00

Table 1. Troubleshooting Procedures—Continued.

MALFUNCTION	TEST OR INSPECTION	CORRECTIVE ACTION
<p>2. ONE OR MORE LAMPS/LEDs (BUT NOT ALL) FAIL TO LIGHT</p>	<p style="text-align: center;"><u>WARNING</u></p> <p>When performing steps 1, 2, 3, and 4 in “TEST OR INSPECTION” column, disconnect intervehicular cable assembly from towing vehicle. Failure to follow this warning may result in injury or death due to electric shock.</p> <p style="text-align: center;">NOTE</p> <p>Refer to page 0002 00-5 for routing of electrical wires and location of electrical components and page 0025 00-1 for electrical schematic.</p> <p>1. Check for loose plug connectors or broken lead wires at inoperative composite light.</p> <p>2. Check inoperative lamp(s)/LED(s).</p> <p>3. Check continuity between edge of light socket and frame.</p> <p>4. Check continuity between center post of light socket and related plug connectors.</p>	<p>1. If plug connectors are loose, push them together; if lead wires are broken, replace them.</p> <p>1. Replace inoperative lamp(s)/LED(s).</p> <p>1. If there is no continuity, slightly tighten hardware securing light (WP 0026 00 or WP 0027 00).</p> <p>2. If there still is no continuity, remove and clean mating surfaces (WP 0026 00 or WP 0027 00).</p> <p>1. If there is no continuity, replace inoperative light (WP 0026 00 or WP 0027 00).</p>

ELECTRICAL SYSTEM ORGANIZATIONAL TROUBLESHOOTING—Continued 0015 00

Table 1. Troubleshooting Procedures—Continued.

MALFUNCTION	TEST OR INSPECTION	CORRECTIVE ACTION
<p>2. ONE OR MORE LAMPS/LEDs (BUT NOT ALL) FAIL TO LIGHT—Continued</p>	<p style="text-align: center;"><u>WARNING</u></p> <p>When performing steps 5, 6, and 7 in “TEST OR INSPECTION” column, intervehicular cable assembly must be connected to towing vehicle and towing vehicle’s lights must be turned on. Use extreme caution when performing the following tests/inspections and procedures. Failure to follow this warning may result in injury or death due to electric shock.</p> <p style="text-align: center;">NOTE</p> <p>Refer to page 0002 00-5 for routing of electrical wires and location of electrical components and page 0025 00-1 for electrical schematic.</p>	<p>5. Check chassis wiring harness plug connectors for presence of 24 V dc.</p> <p>6. Check intervehicular cable assembly plug connectors for presence of 24 V dc.</p> <p>7. Check towing vehicle receptacle pin connector for presence of 24 V dc.</p>
		<p>1. If 24 V dc are not present, proceed to step 6.</p> <p>1. If 24 V dc are present, replace chassis wiring harness (WP 0028 00).</p> <p>2. If 24 V dc are not present, proceed to step 7.</p> <p>1. If 24 V dc are present, replace intervehicular cable assembly (WP 0029 00).</p> <p>2. If 24 V dc are not present, refer to towing vehicle Organizational maintenance manual.</p>

END OF TASK

BRAKE SYSTEM ORGANIZATIONAL TROUBLESHOOTING

0016 00

THIS WP COVERS:

Brakes Troubleshooting

INITIAL SETUP:

Maintenance Level

Organizational

Tools and Special Tools

Tool Kit, General Mechanic's

Materials/Parts

Fluid, Brake (Item 4, WP 0060 00)

References

WP 0020 00	WP 0032 00
WP 0023 00	WP 0033 00
WP 0031 00	WP 0038 00

To troubleshoot the brakes, perform the tests/inspections and corrective actions provided in Table 1.

Table 1. Troubleshooting Procedures.

MALFUNCTION	TEST OR INSPECTION	CORRECTIVE ACTION
1. BRAKES DO NOT ENGAGE HYDRAULICALLY	1. Check fluid level in brake actuator master cylinder. It should be 3/4 full. 2. Check brake hose and tubes for obstruction or damage. 3. Check for worn brakeshoe linings. Brakeshoe linings should have a minimum thickness of 0.125 in. (3.2 mm).	1. Fill brake actuator master cylinder to 3/4 full (WP 0023 00). Then bleed brake system (WP 0038 00). 1. Clear obstruction or replace damaged hose or tube(s). 1. Replace brakeshoes if linings are worn (WP 0033 00).
1. BRAKES DO NOT ENGAGE MECHANICALLY	1. Check handbrake rod, turnbuckles, shaft assembly, and cable assemblies for damage and proper adjustment.	1. Replace handbrake rod, turnbuckles, shaft assembly, or cable assemblies, or adjust handbrake, as required (WP 0032 00).
2. BRAKES GRAB	1. Check for proper brake adjustment.	1. If brakes are out of adjustment, adjust brakes (WP 0033 00).

Table 1. Troubleshooting Procedures—Continued.

MALFUNCTION	TEST OR INSPECTION	CORRECTIVE ACTION
2. BRAKES GRAB—Continued	2. Check for grease or dirt on brakeshoe linings. 3. Check for worn or loose brakeshoe linings. Brakeshoe linings should have a minimum thickness of 0.125 in. (3.2 mm).	1. If grease or dirt is present, replace affected brakeshoe(s). 1. Replace brakeshoes if linings are worn or loose (WP 0033 00).
3. BRAKES DO NOT RELEASE	1. Check handbrake rod, turnbuckles, shaft assembly, and cable assemblies for damage and proper adjustment. 2. In cold weather, check for frozen brakeshoe linings. 3. Check for proper brake adjustment.	1. Replace handbrake rod, turnbuckles, shaft assembly, or cable assemblies, or adjust handbrake, as required (WP 0032 00). 1. Remove wheel (WP 0020 00). Heat brakedrum to thaw. 1. If brakes are out of adjustment, adjust brakes (WP 0033 00).

END OF TASK

CHAPTER 5
OPERATOR MAINTENANCE INSTRUCTIONS
FOR
M105A3 CARGO TRAILER

**OPERATOR/CREW PREVENTIVE MAINTENANCE
CHECKS AND SERVICES (PMCS)**

0017 00

THIS WP COVERS:

PMCS Procedures

INITIAL SETUP:

Maintenance Level

Operator/Crew

Tools and Special Tools

Gage, Tire Pressure

Materials/Parts

Rags, Wiping (Item 9, WP 0060 00)
Solvent, Cleaning (Item 10, WP 0060 00)

References

WP 0002 00 WP 0018 00
WP 0011 00 WP 0019 00
WP 0012 00

GENERAL

To ensure that the M105A3 Trailer is ready for operation at all times, it must be inspected on a regular basis so that defects may be found before they result in serious damage, equipment failure, or injury to personnel. This section contains systematic instructions on inspections, adjustments, and corrections to be performed by the operator/crew.

While performing Preventive Maintenance Checks and Services (PMCS), read and follow all safety instructions in the warning summary at the front of this manual. Keep in mind all warnings and cautions throughout PMCS.

SERVICE INTERVALS

Perform PMCS, found in Table 1, at the following intervals:

Perform "Before" PMCS just before operating the trailer.

Perform "During" PMCS while operating the trailer.

Perform "After" PMCS immediately after operating the trailer.

REPORTING REPAIRS

All defects that the operator cannot fix must be reported on a DA Form 2404, Equipment Inspection and Maintenance Worksheet, immediately after completing PMCS. If a serious problem is found, IMMEDIATELY report it to your supervisor. Remember, record any corrective action taken.

GENERAL PMCS PROCEDURES

WARNING

Solvents can burn easily, can give off harmful vapors, and are harmful to skin and clothing. To avoid injury or death, keep away from open fire and use in a well-ventilated area. If solvent gets on skin or clothing, wash immediately with soap and water.

**OPERATOR/CREW PREVENTIVE MAINTENANCE
CHECKS AND SERVICES (PMCS)—Continued**

0017 00

GENERAL PMCS PROCEDURES—Continued

Keep equipment clean. Dirt, oil, and debris may cover up a serious problem. Clean as you work and as needed. Use cleaning solvent on all metal surfaces. Use soap and water on rubber, plastic, and painted surfaces.

While performing specific PMCS procedures, inspect the following components:

Bolts, Nuts, and Screws. Ensure that they are not loose, missing, bent, or broken. Report loose or missing bolts, nuts, and screws to Organizational maintenance.

Welds. Inspect for gaps where parts are welded together. Check for loose or chipped paint, rust, and cracks. Report bad welds to Organizational maintenance.

Electrical Conduit, Wires, and Connectors. Inspect for cracked or broken insulation, bare wires, and loose or broken connectors. Report loose connections and faulty wiring to Organizational maintenance.

Hose, Lines, and Fittings. Inspect for wear, damage, and leaks. Ensure that clamps and fittings are tight. Report any damage, leaks, or loose fittings and clamps to Organizational maintenance.

Check that components are adequately lubricated in accordance with WP 0018 00.

SPECIFIC PMCS PROCEDURES

Operator/crew PMCS is provided in Table 1. Always perform PMCS in the order listed. Once it becomes a habit, anything that is not right can be spotted in a minute.

Before performing PMCS, read all the checks required for the applicable interval and prepare all the tools needed. Have several clean rags handy. Perform all inspections at the applicable interval.

If any problems are found through PMCS, perform the appropriate troubleshooting task in WP 0011 00 or 0012 00.

The column headings in Table 1 are defined as follows:

Item No. Provides a logical sequence for PMCS to be performed and is used as a source of item numbers for the "TM ITEM NO." column when recording PMCS results on DA Form 2404. Item numbers also appear in the order that you must perform checks and services for the intervals listed.

Interval. Specifies the interval at which PMCS is to be performed.

Item To Check/Service. Lists the system and common name of items that are to be inspected. Included in this column are specific servicing, inspection, replacement, or adjustment procedures to be followed.

Procedure. Provides the procedure that must be performed to check or service the item. Carefully follow these instructions. If you do not have the tools, have Organizational maintenance perform the work.

Not Fully Mission Capable If: Explains when the trailer is nonmission-capable. This column tells you when and why your equipment cannot be used.

LEAKAGE DEFINITIONS

It is important to know how fluid leakage affects the status of the trailer. Following are types/classes of leakage an operator must know to determine whether the trailer is mission capable. Learn these leakage definitions. When in doubt, notify your supervisor.

Class I. Seepage of fluid (as indicated by wetness or discoloration) not great enough to form drops.

Class II. Leakage of fluid great enough to form drops, but not great enough to cause drops to drip from item being checked/inspected.

Class III. Leakage of fluid great enough to form drops that fall from item being checked/inspected.

CAUTION

Equipment operation is allowable with minor leakage (Class I or II). Of course, consideration must be given to fluid capacity in item/system being checked/inspected. When in doubt, notify your supervisor. Operation with major leakage may cause equipment damage.

Equipment operation is allowed with minor (Class I or II) leakage. Fluid levels in an item/system affected with such leakage must be checked more frequently than required in PMCS. When in doubt, notify your supervisor. Report Class III leaks IMMEDIATELY to your supervisor.

OPERATOR/CREW PREVENTIVE MAINTENANCE CHECKS AND SERVICES (PMCS)—Continued

0017 00

Table 1. Operator/Crew PMCS.

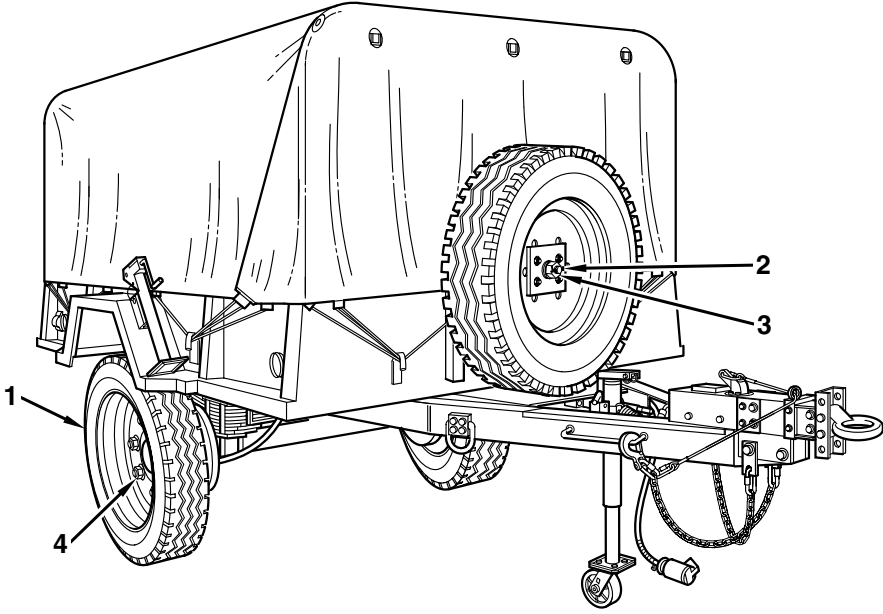
ITEM NO.	INTERVAL	ITEM TO CHECK/SERVICE	PROCEDURE (Check for and have repaired, filled, or adjusted as needed)	NOT FULLY MISSION CAPABLE IF:
NOTE				
<p>Perform Weekly as well as Before PMCS if you are the assigned operator, but have not operated the trailer since last Weekly PMCS, or if you are operating the trailer for the first time.</p>				
1	Before	Wheels and Tires	<p>a. Check tires (1) (including spare) for obviously low pressure, deep cuts, foreign objects, or unusual tread wear (TM 9-2610-200-24). Remove stones caught between tire treads.</p> <p>b. Check for missing or obviously loose wheel nuts (4).</p> <p>c. Check that cotter pin (2) and nut (3) are present and tight.</p>	<p>Tire flat, missing, or unserviceable.</p> <p>Two or more wheel nuts loose or missing (on one wheel).</p> <p>Spare wheel nut loose or missing.</p>
NOTE				
<p>Have Organizational maintenance tighten nuts (4) to 385 lb-ft (522 N•m) as soon as possible using tightening sequence shown in WP 0020 00.</p>				
 <p>The diagram shows a side view of a trailer with a canvas cover. Callout 1 points to the front tire. Callout 2 points to a cotter pin on the spare wheel hub. Callout 3 points to a nut on the spare wheel hub. Callout 4 points to a wheel nut on the front tire.</p>				

**OPERATOR/CREW PREVENTIVE MAINTENANCE
CHECKS AND SERVICES (PMCS)—Continued**

0017 00

Table 1. Operator/Crew PMCS—Continued.

ITEM NO.	INTERVAL	ITEM TO CHECK/SERVICE	PROCEDURE (Check for and have repaired, filled, or adjusted as needed)	NOT FULLY MISSION CAPABLE IF:
2	Before	Frame and Suspension	a. Check frame (5) for cracks and broken welds. b. Inspect springs and suspension (6) for loose, damaged, broken, or missing components.	Welds cracked or broken. Components damaged, loose, broken, or missing.
3	Before	Composite and Running Lights and Reflectors	a. Check composite lights (8), running lights (7), and reflectors (9) for damage. b. Check composite lights (8) and running lights (7) for proper operation.	

NOTE

An assistant is required when checking lights.

		c. If tactical situation permits, connect intervehicular cable assembly to towing vehicle and check all lights for proper operation.	Brake and taillights are inoperable.
--	--	--	--------------------------------------

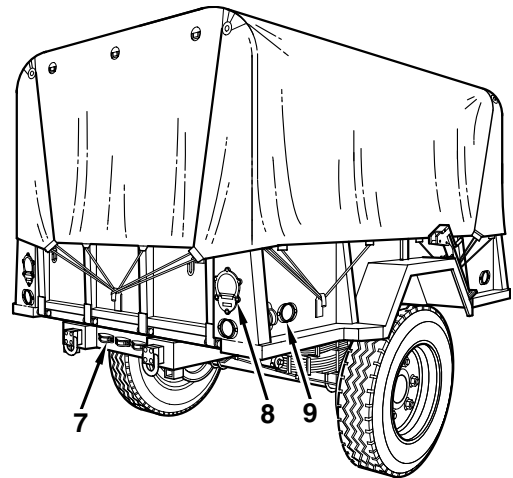
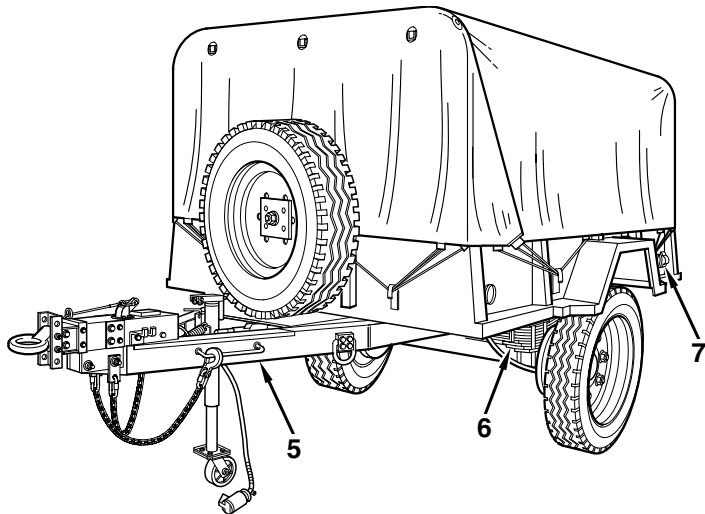

**OPERATOR/CREW PREVENTIVE MAINTENANCE
CHECKS AND SERVICES (PMCS)—Continued**

0017 00

Table 1. Operator/Crew PMCS—Continued.

ITEM NO.	INTERVAL	ITEM TO CHECK/SERVICE	PROCEDURE (Check for and have repaired, filled, or adjusted as needed)	NOT FULLY MISSION CAPABLE IF:
4	Before	Landing Gear	a. Check landing gear (10) for proper mounting, alignment, and general condition. b. Check landing gear (10) for proper operation of release handle. c. When cranking landing gear, check that shaft turns smoothly and that leg moves without binding or grinding.	Release handle damaged. Landing gear inoperable. Landing gear binds or grinds. Landing gear inoperable.

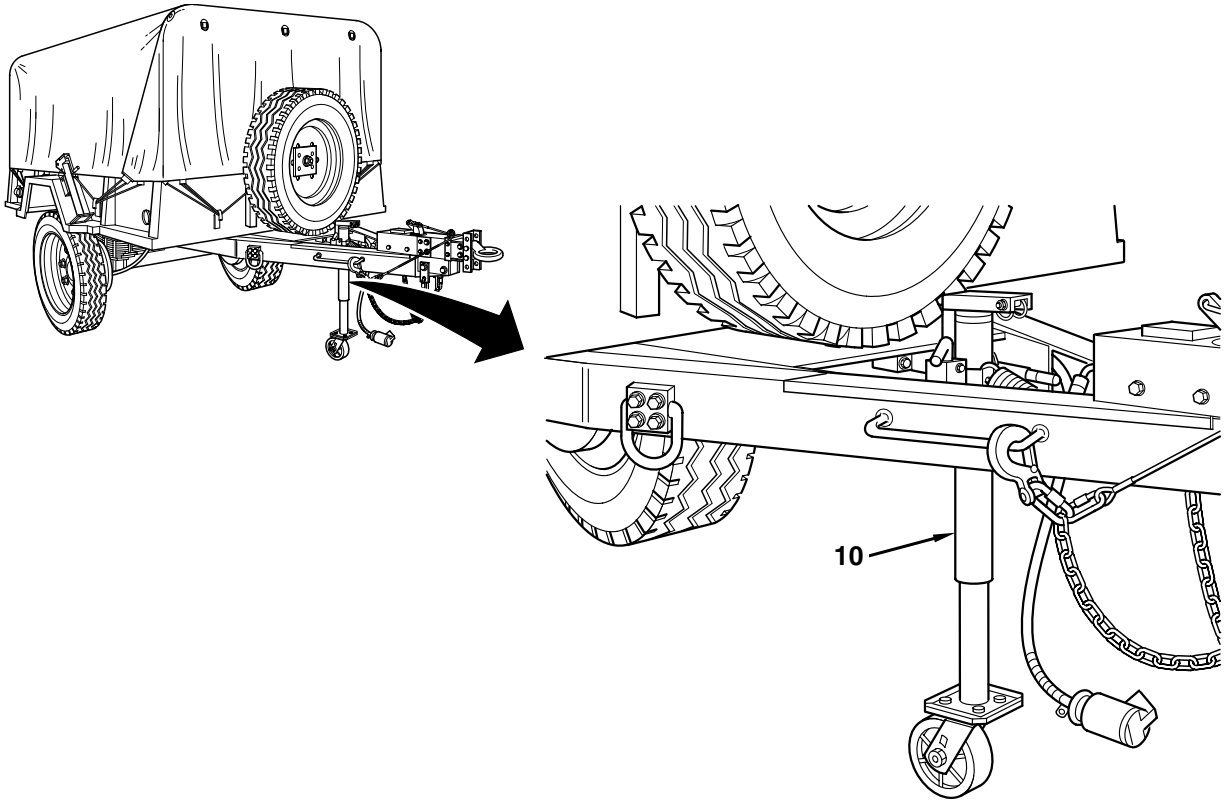

**OPERATOR/CREW PREVENTIVE MAINTENANCE
CHECKS AND SERVICES (PMCS)—Continued**

0017 00

Table 1. Operator/Crew PMCS—Continued.

ITEM NO.	INTERVAL	ITEM TO CHECK/SERVICE	PROCEDURE (Check for and have repaired, filled, or adjusted as needed)	NOT FULLY MISSION CAPABLE IF:
5	Before	Drawbar Coupler and Safety Chains	Check drawbar coupler (11) and safety chains (13) for damage.	Drawbar coupler cracked or otherwise damaged. Safety chains damaged or missing.
6	Before	Intervehicular Cable Assembly	a. Check general condition of intervehicular cable assembly (12). b. Check terminals for corrosion or damage, and missing or damaged pins.	Terminals are damaged.

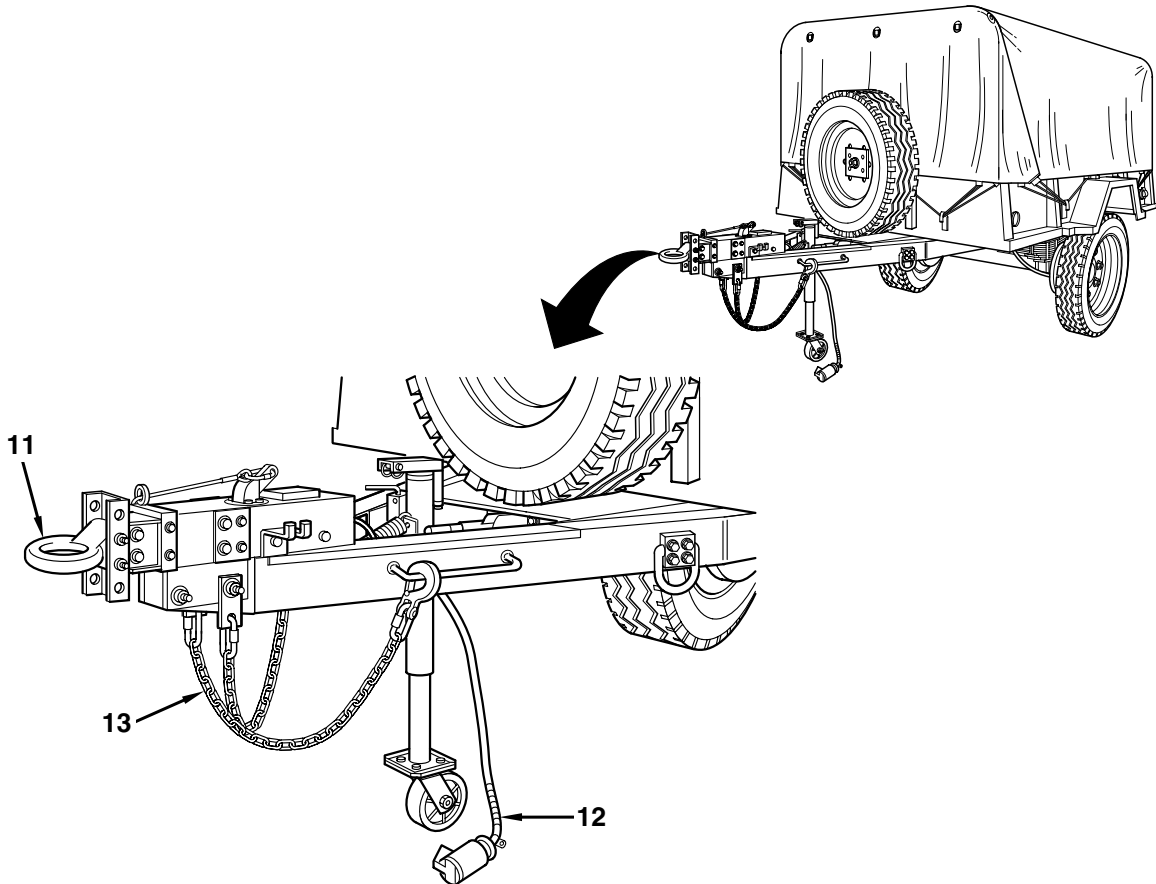
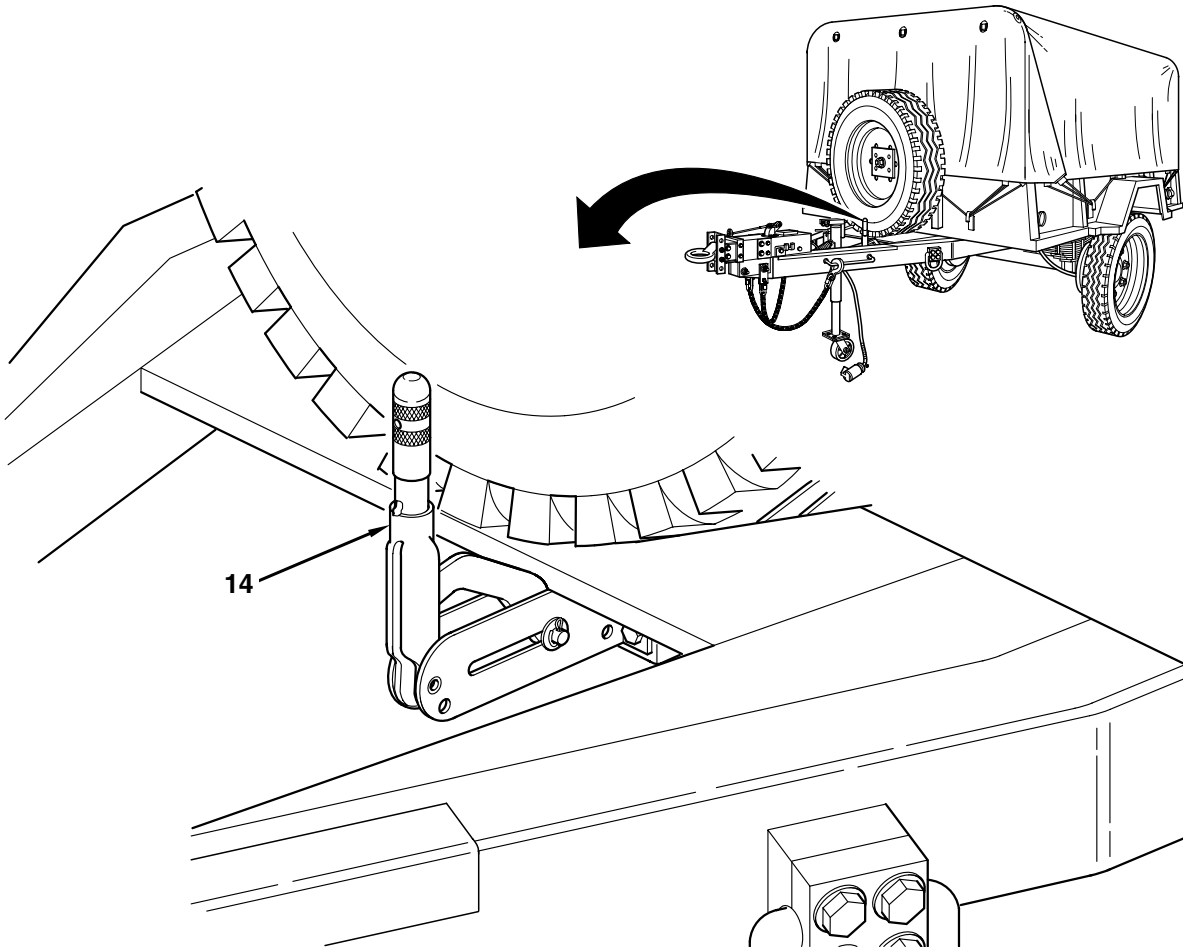

Table 1. Operator/Crew PMCS—Continued.

ITEM NO.	INTERVAL	ITEM TO CHECK/SERVICE	PROCEDURE (Check for and have repaired, filled, or adjusted as needed)	NOT FULLY MISSION CAPABLE IF:
7	Before	Handbrake	a. Check handbrake lever (14) for proper operation, including that both wheels are engaging. b. Check handbrake lever (14) for proper adjustment. Handbrake lever is properly adjusted when additional force is required to move handbrake lever beyond 2/3 distance of travel toward the applied position (WP 0019 00).	



**OPERATOR/CREW PREVENTIVE MAINTENANCE
CHECKS AND SERVICES (PMCS)—Continued**

0017 00

Table 1. Operator/Crew PMCS—Continued.

ITEM NO.	INTERVAL	ITEM TO CHECK/SERVICE	PROCEDURE (Check for and have repaired, filled, or adjusted as needed)	NOT FULLY MISSION CAPABLE IF:
8	Before	Brake System	Check for brake fluid leakage from brake actuator master cylinder (15), hoses, tubes, tube assemblies, and fittings. Check for loose or missing bracket, clip, and clamps.	Class III leakage is found.

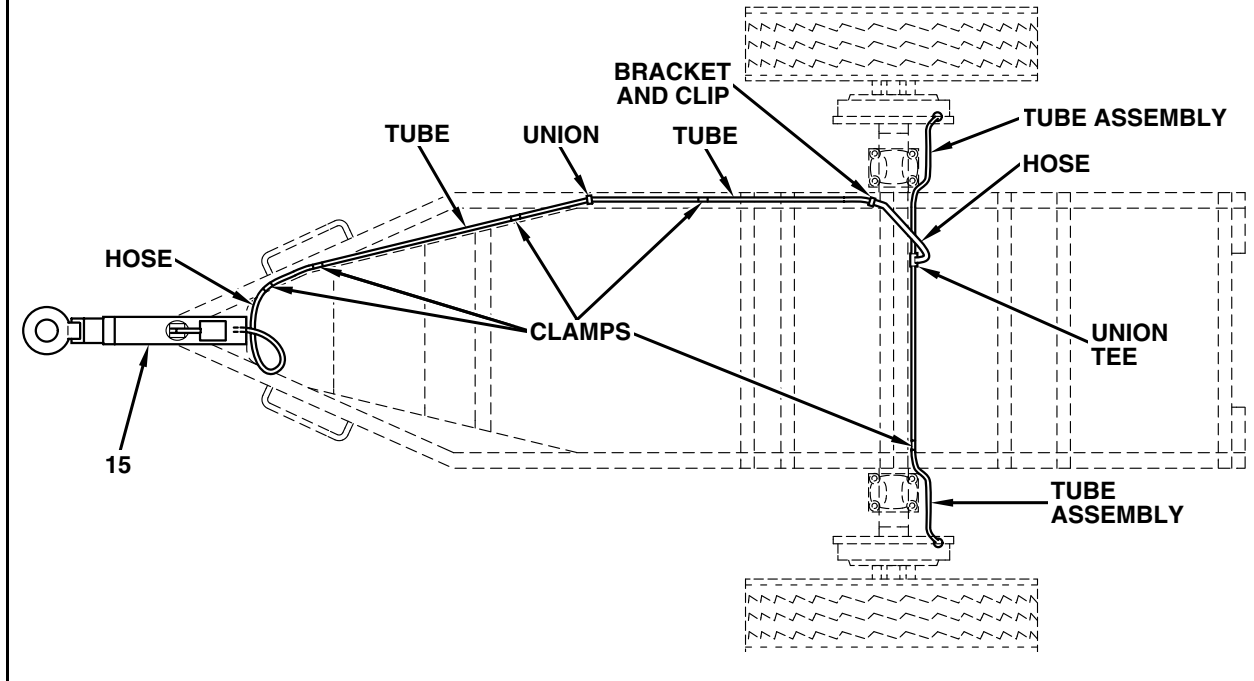

**OPERATOR/CREW PREVENTIVE MAINTENANCE
CHECKS AND SERVICES (PMCS)—Continued**

0017 00

Table 1. Operator/Crew PMCS—Continued.

ITEM NO.	INTERVAL	ITEM TO CHECK/SERVICE	PROCEDURE (Check for and have repaired, filled, or adjusted as needed)	NOT FULLY MISSION CAPABLE IF:
9	Before	Body	a. Check that stake racks (16) and roof bows (17) are properly installed and not damaged. b. Check that tarpaulin (18) is not torn or damaged and is properly tied down.	

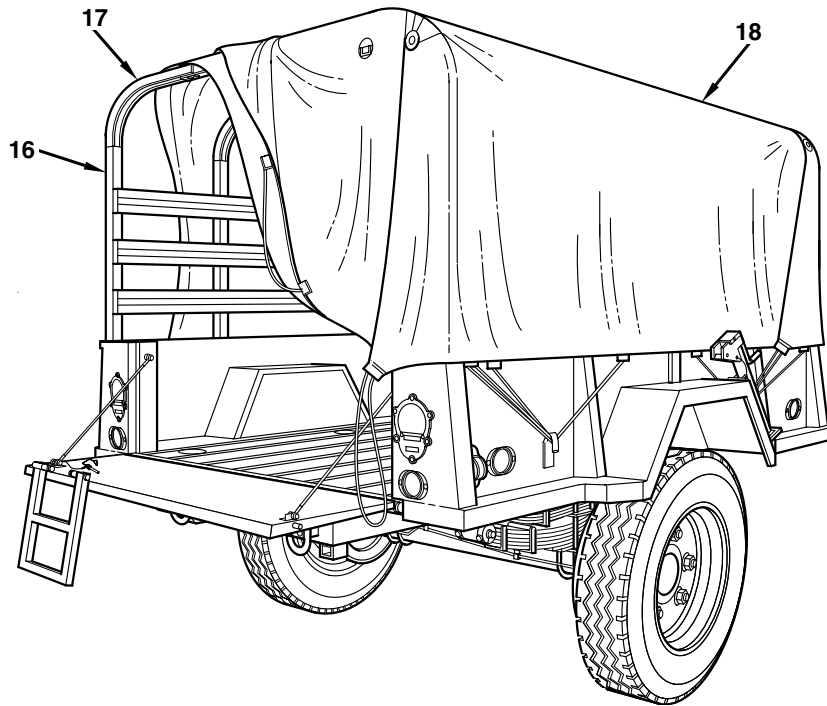

**OPERATOR/CREW PREVENTIVE MAINTENANCE
CHECKS AND SERVICES (PMCS)—Continued**

0017 00

Table 1. Operator/Crew PMCS—Continued.

ITEM NO.	INTERVAL	ITEM TO CHECK/SERVICE	PROCEDURE (Check for and have repaired, filled, or adjusted as needed)	NOT FULLY MISSION CAPABLE IF:
10	Before	Stabilizer	a. Check that stabilizer (19) and lockpin (20) are present. b. Check stabilizer (19) for proper operation.	

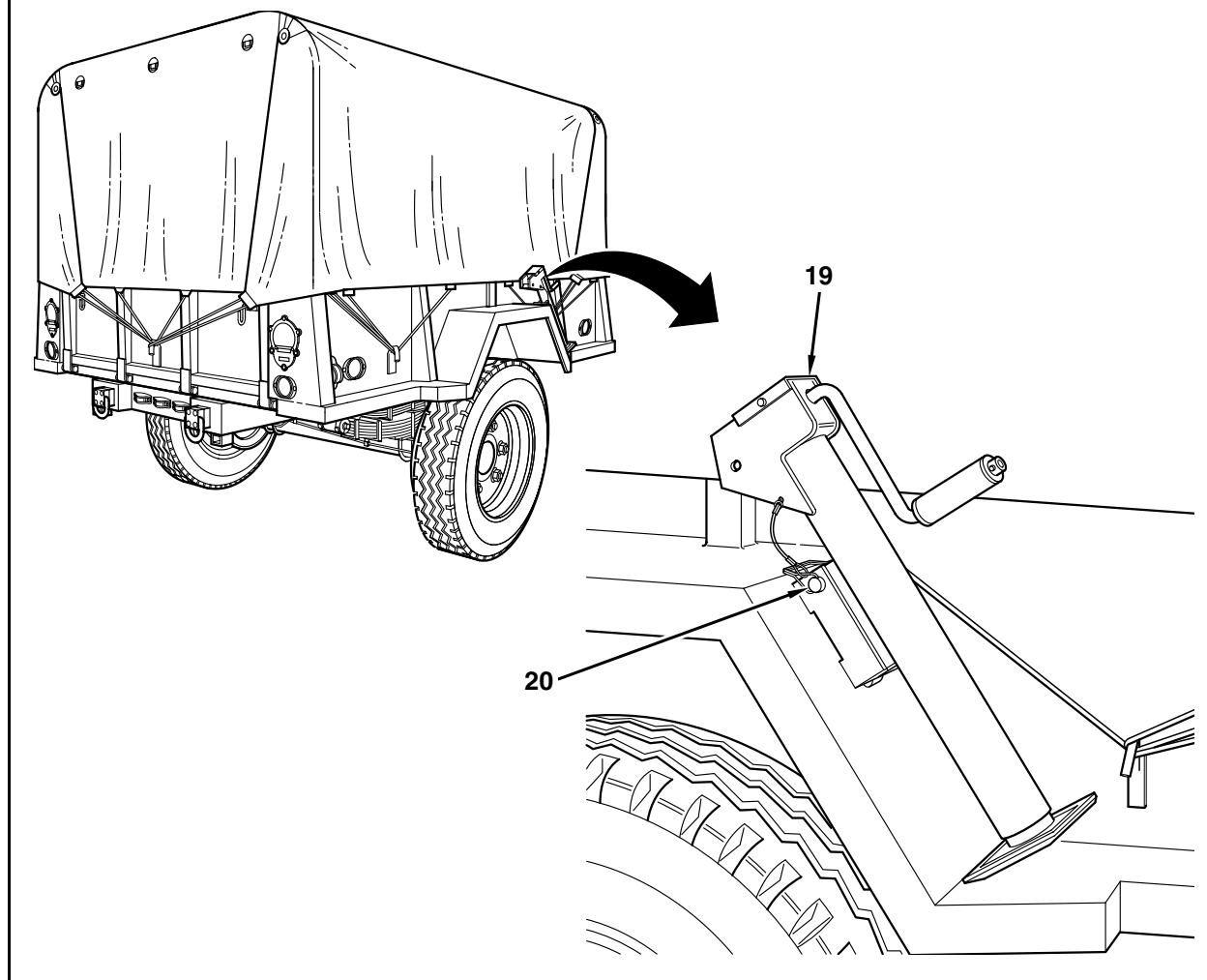

**OPERATOR/CREW PREVENTIVE MAINTENANCE
CHECKS AND SERVICES (PMCS)—Continued**

0017 00

Table 1. Operator/Crew PMCS—Continued.

ITEM NO.	INTERVAL	ITEM TO CHECK/SERVICE	PROCEDURE (Check for and have repaired, filled, or adjusted as needed)	NOT FULLY MISSION CAPABLE IF:
11	During	Brake System	Check for proper operation of service brakes.	Brakes do not operate properly.
12	After	Wheels	Check wheels for damage and for loose or missing wheel nuts. If loose, tighten and notify Organizational maintenance.	Two or more wheel nuts on one wheel missing or wheel damaged.
13	After	Trailer Body	Visually inspect parts such as tailgate and release handles for damage.	
14	After	Frame and Associated Parts	Perform general inspection of frame, stake racks, roof bows, tarpaulin, and landing gear.	

OPERATOR/CREW LUBRICATION INSTRUCTIONS

0018 00

THIS WP COVERS:

Lubrication Instructions

INITIAL SETUP:

Maintenance Level

Operator/Crew

Materials/Parts

Oil, Lubrication (Item 7, WP 0060 00)

Oil, Lubrication (Item 8, WP 0060 00)

Solvent, Cleaning (Item 10, WP 0060 00)

References

FM 9-207

GENERAL

NOTE

These instructions are mandatory.

The trailer must receive lubrication with the approved lubricants at the recommended interval in order to be mission-ready at all times.

The KEY lists the lubricants to be used in all temperature ranges and shows the interval.

The lubrication chart shows the lubrication points, names the item to be lubricated, the required lubricants, and recommended interval for lubrication. Special lubricating instructions are contained in the NOTE section of the chart.

The recommended interval is based on normal conditions of operation, temperature, and humidity. When operating under extreme conditions, the lubricants should always be changed more frequently. When in doubt, notify your supervisor.

SPECIFIC LUBRICATION INSTRUCTIONS

Keep the lubricants in closed containers and store in a clean, dry place away from extreme heat. Keep container covers clean and do not allow dust, dirt, or other foreign material to mix with lubricant. Keep lubrication equipment clean and ready for use.

Maintain a record of lubrication performed and report any problems noted during lubrication. Refer to DA PAM 738-750 for maintenance forms and procedures to record and report any findings.

Keep all external parts of equipment not requiring lubrication free of lubricants. After lubrication, wipe off excess oil to prevent accumulation of foreign matter.

Refer to FM 9-207 for lubrication instructions in cold weather.

After operation in mud, sandy, or dusty conditions, clean and inspect the points of lubrication for fouled lubricants. Change lubricants as required.

LUBRICATION CHART

The interval (on-condition and hard time) and related man-hour time specified is the time you need to do the service prescribed for a particular interval. Decrease the interval if your lubricants are contaminated, or if you are operating equipment under adverse conditions, including longer-than-usual operating hours. The interval may be extended during periods of low activity. If extended, adequate preservation precautions must be taken.

The dotted leader line indicates lubrication is required on both sides of the trailer.

WARNING

Solvents can burn easily, can give off harmful vapors, and are harmful to skin and clothing. To avoid injury or death, keep away from open fire and use in a well-ventilated area. If solvent gets on skin or clothing, wash immediately with soap and water.

Clean the area around the lubrication points with cleaning solvent or equivalent before lubricating equipment. After lubrication, wipe off excess oil to prevent accumulation of foreign matter.

LUBRICATION CHART—Continued

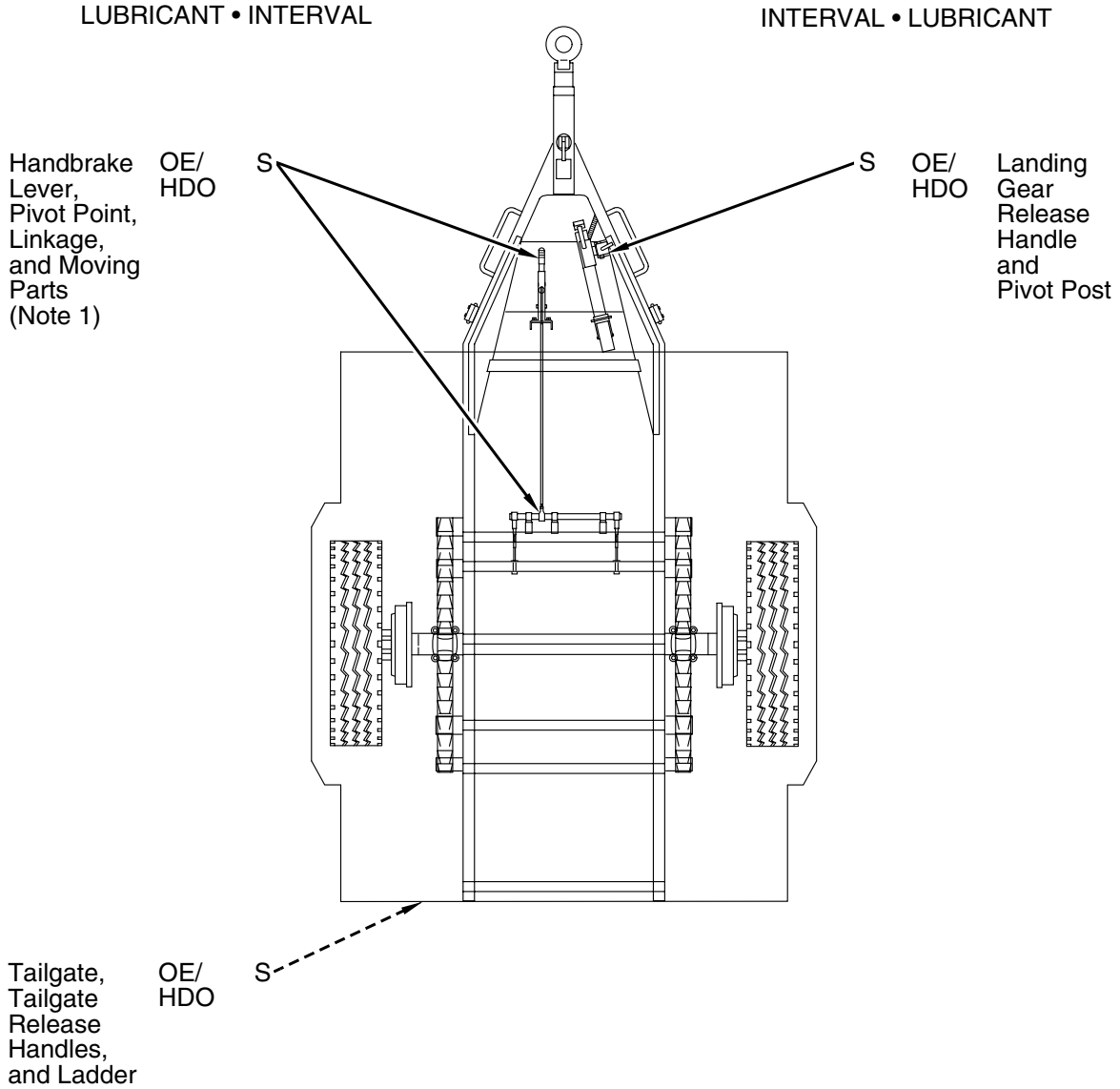

TOTAL MAN-HOUR*	
INTERVAL	MAN-HOUR
S	0.5

*The man-hour time specified is the time you need to do all services prescribed for the particular interval.

LUBRICATION CHART—Continued

—KEY—

LUBRICANTS	EXPECTED TEMPERATURES*			INTERVAL
	ABOVE +15°F (ABOVE -9°C)	+40°F to -15°F (+4°C to -26°C)	+40°F to -65°F (+4°C to -54°C)	
OE/HDO (MIL-L-2104) Lubricating Oil, Internal Combustion Engine, Tactical Service	OE/HDO-30	OE/HDO-30	—	S—Semiannual
OEA (MIL-L-46167) Lubricating Oil, Internal Combustion Engine, Arctic	—	—	OEA	

*For Arctic operation, refer to FM 9-207.

NOTE:

1. **Oil Can Points.** Every 6 months, lubricate handbrake, linkage, bushings, pins, clevises, moving parts, and all exposed adjusting threads with OE/HDO.

END OF TASK

HANDBRAKE LEVER ADJUSTMENT

0019 00

THIS WP COVERS:

Adjustment

INITIAL SETUP:

Maintenance Level

Operator/Crew

ADJUSTMENT

WARNING

If trailer is not coupled to towing vehicle, ensure that landing gear is lowered and locked and wheels are securely chocked. Failure to follow this warning may cause trailer to roll, resulting in injury to personnel or damage to equipment.

NOTE

- Handbrake is properly adjusted when additional force is required to move handbrake lever (2) beyond 2/3 distance of travel toward applied position.
- If one brake is not engaging, do not adjust handbrake lever; have Organizational maintenance adjust cables as specified in WP 0032 00.

1. Release handbrake by raising handbrake lever (2) up to vertical position.
2. Turn adjustment knob (1) clockwise to increase tension or counterclockwise to decrease tension.

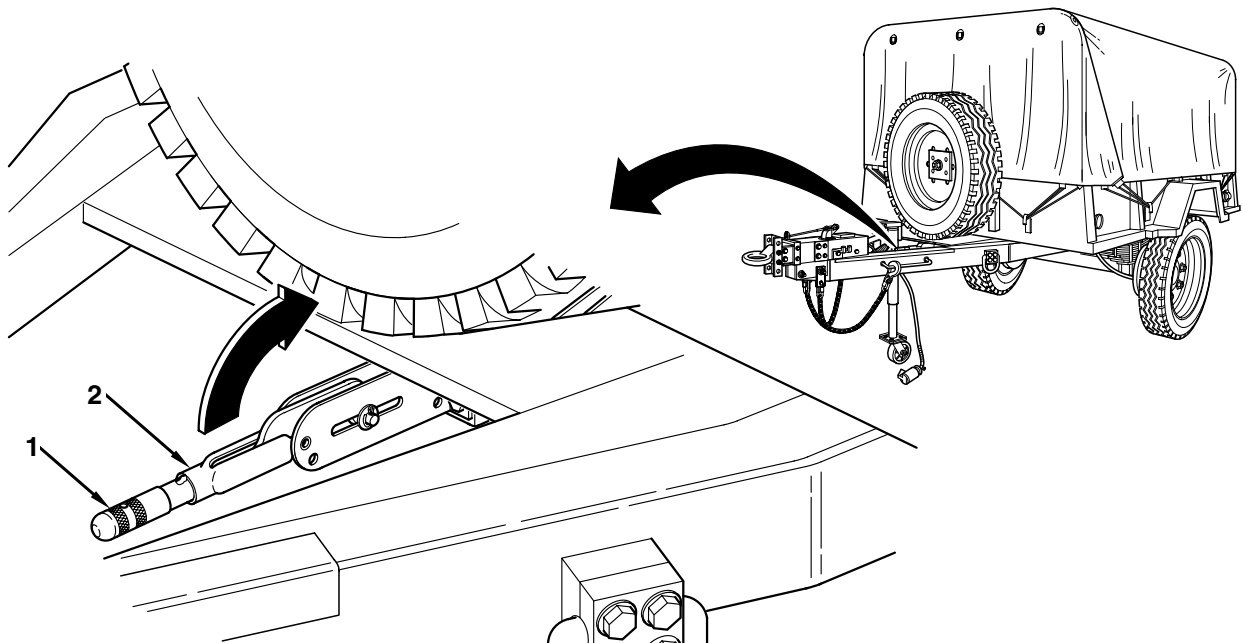

HANDBRAKE LEVER ADJUSTMENT—Continued

0019 00

ADJUSTMENT—Continued

3. Check adjustment. Repeat steps 1 and 2 as required.
4. If handbrake is still not adjusted correctly, notify Organizational maintenance.

END OF TASK

WHEEL REPLACEMENT

0020 00

THIS WP COVERS:

Removal, Installation

INITIAL SETUP:

Maintenance Level

Operator/Crew

Materials/Parts

Cotter Pin (Item 5, WP 0061 00)

Personnel

Two

REMOVAL

WARNING

Replace wheel with trailer coupled to towing vehicle if possible. If trailer is not coupled to towing vehicle, ensure that landing gear is lowered and locked and chock wheel not being replaced. Failure to follow this warning may cause trailer to roll, resulting in injury to personnel or damage to equipment.

1. Apply trailer handbrake by lowering handbrake lever (1) down to horizontal position.

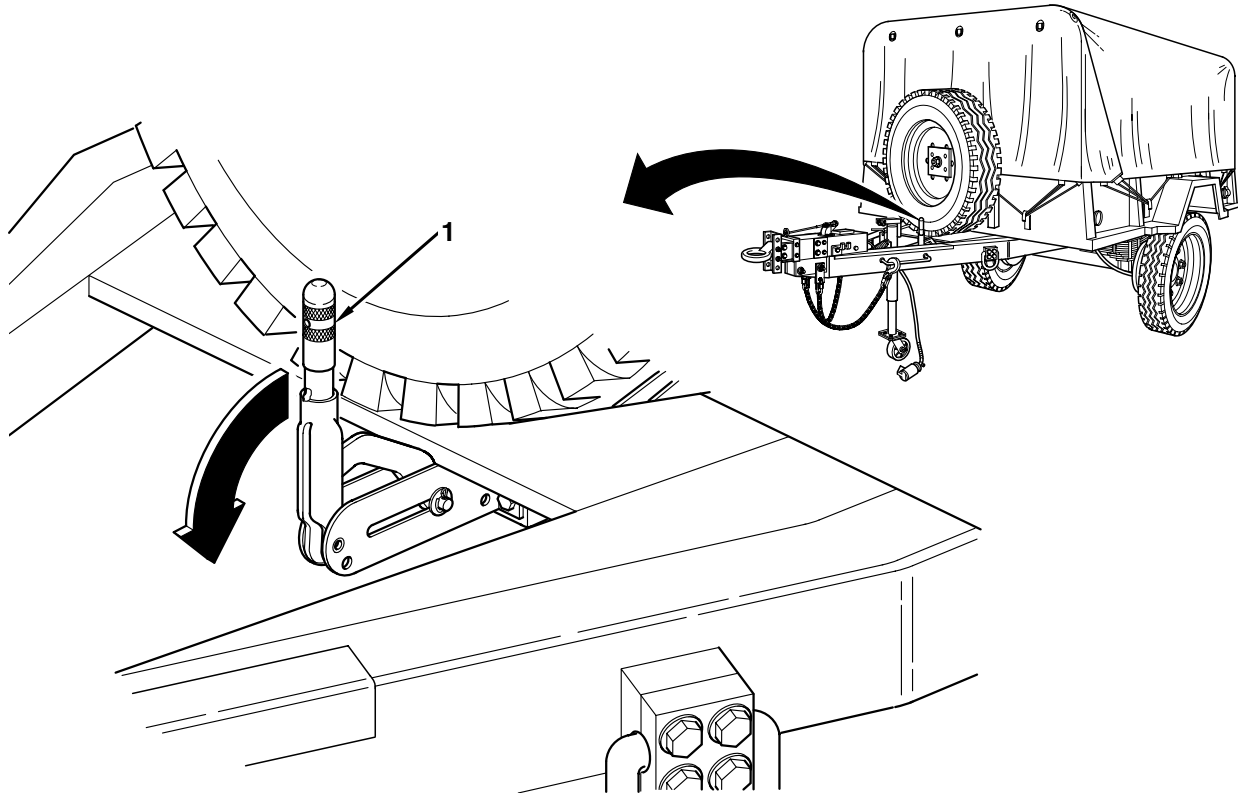

REMOVAL—Continued

2. Remove lockpin (4) from bracket (3) and remove stabilizer (2).

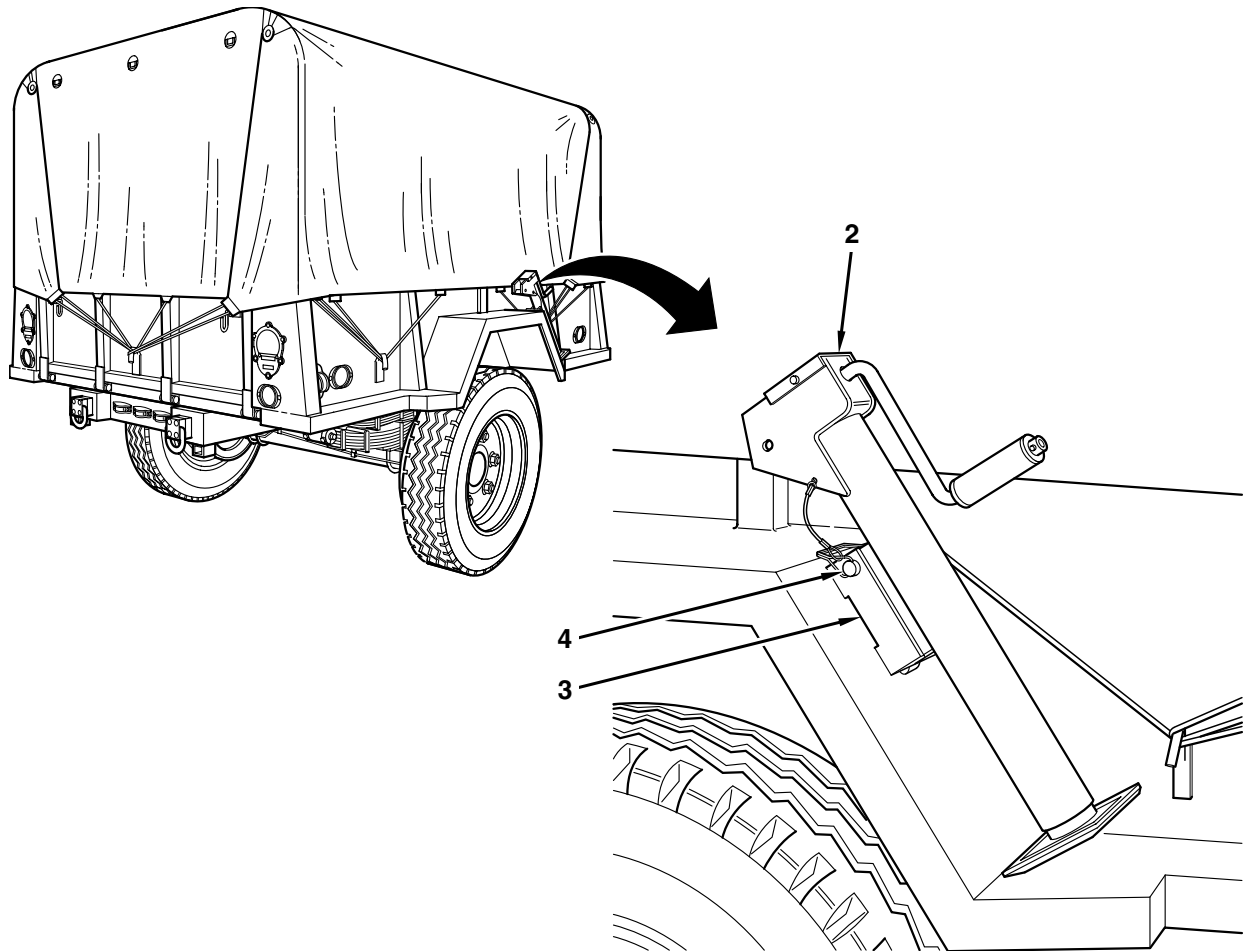

REMOVAL—Continued

3. Install stabilizer (2) on mount (6) and secure with lockpin (4). Extend stabilizer by turning handle (5) counterclockwise until stabilizer makes contact with ground.

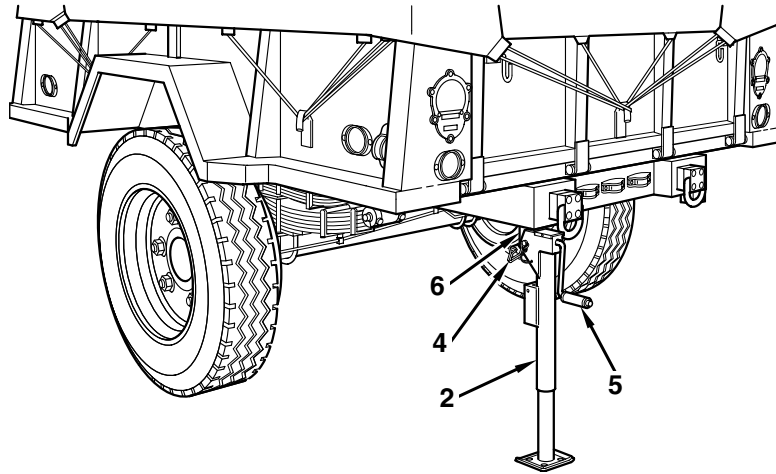

WARNING

Spare wheel (7) weighs 185 lb (84 kg). Use two people to remove spare wheel from stowed position. Failure to follow this warning could result in injury to personnel.

4. Remove cotter pin (11), nut (10), flatwasher (9), plate (7), and spare wheel (8). Discard cotter pin.

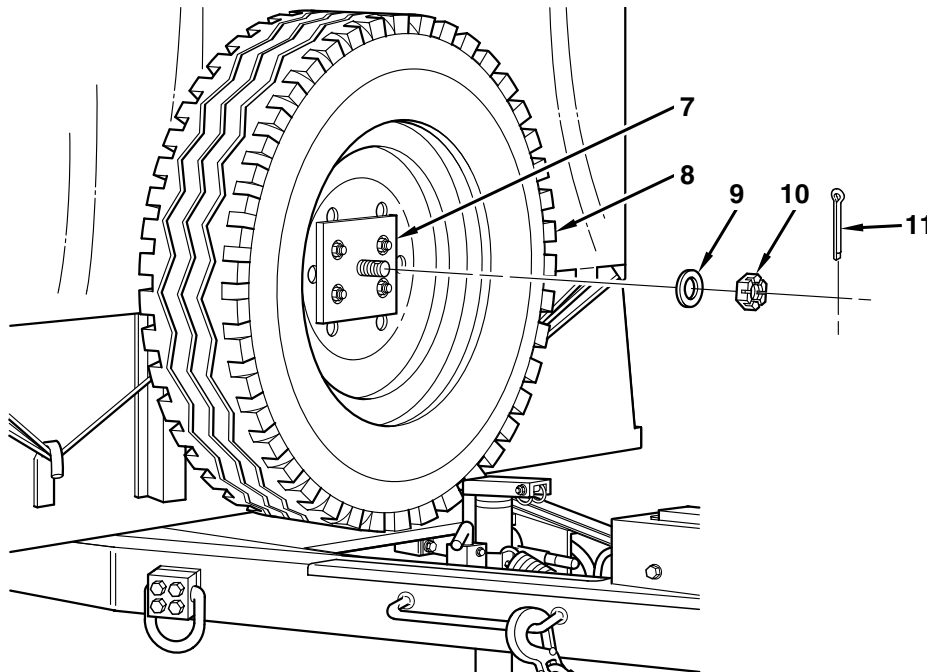

REMOVAL—Continued

5. Break loose but do not remove six wheel nuts (12) from hub studs (13).
6. Raise side of trailer by turning handle (5) of stabilizer (2) counterclockwise until wheel (15) clears ground.
7. Remove six wheel nuts (12).

WARNING

Wheel (14) weighs 185 lb (84 kg). Use two people to remove wheel from hub studs (13). Failure to follow this warning could result in injury to personnel.

8. Remove wheel (14) from hub studs (13).

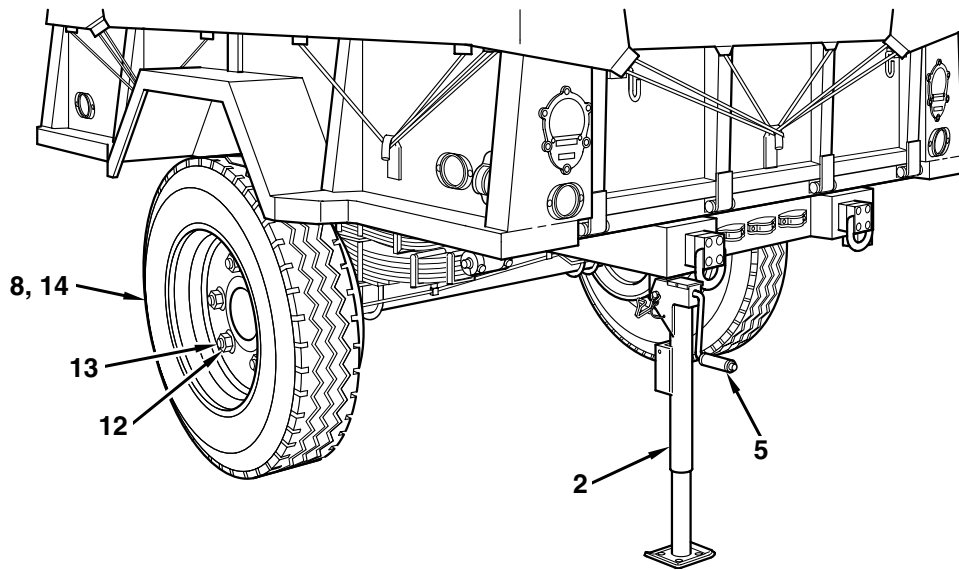

INSTALLATION

WARNING

Spare wheel (7) weighs 185 lb (84 kg). Use two people to install spare wheel on hub studs (13). Failure to follow this warning could result in injury to personnel.

NOTE

Before installing spare wheel (8), be sure that mounting surfaces of hub and flat mounting surfaces of wheel are clean and free of foreign matter or excess paint. Check to see that threads of studs are clean and not damaged.

1. Install spare wheel (8) on hub studs (13).
2. Install six wheel nuts (12) fingertight.
3. Lower side of trailer until spare wheel (8) just makes contact with ground by turning handle (5) of stabilizer (2) clockwise.

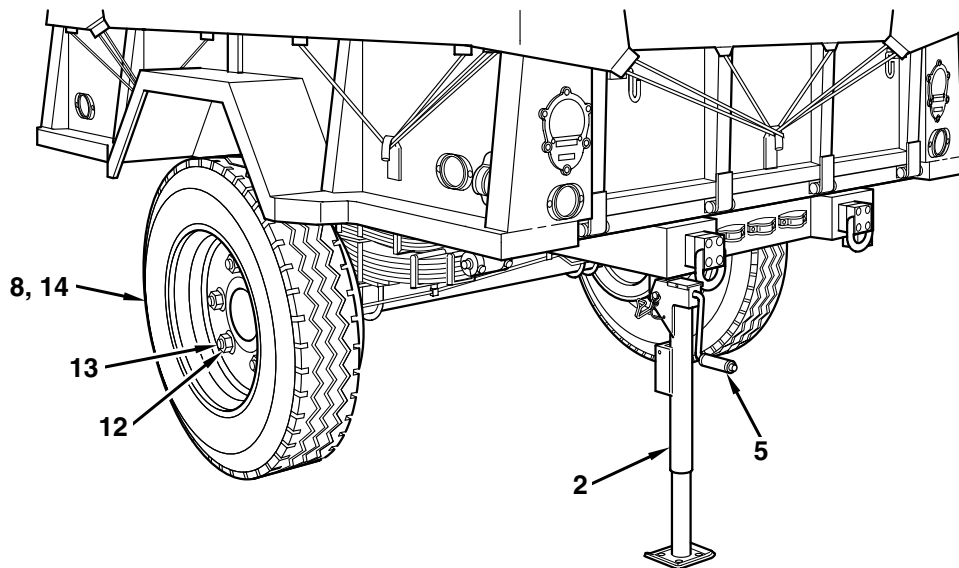

INSTALLATION—Continued

4. Tighten six wheel nuts (12) using tightening sequence shown below.

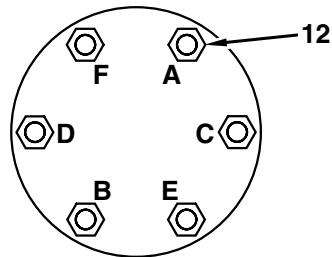

5. Lower side of trailer completely, remove stabilizer (2), stow in bracket (3), and lock in position with lockpin (4).

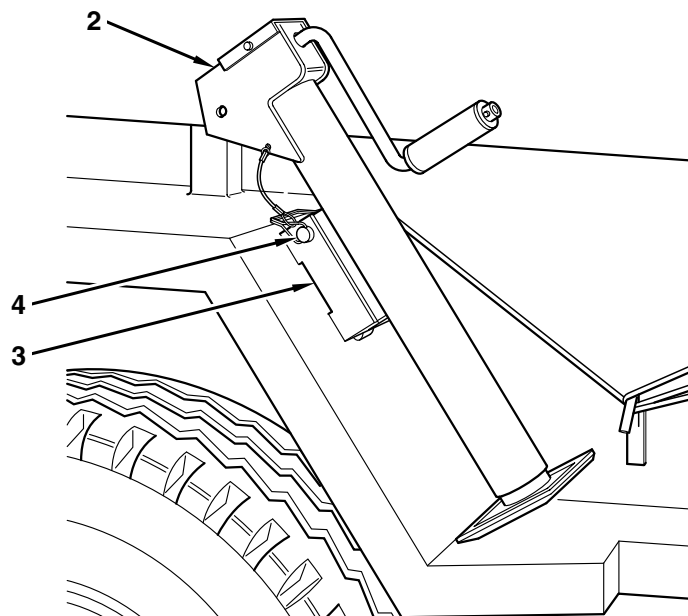

INSTALLATION—Continued

WARNING

Wheel (14) weighs 185 lb (84 kg). Use two people to install wheel in stowed position. Failure to follow this warning could result in injury to personnel.

NOTE

Stow spare wheel (14) with valve stem side of wheel toward trailer.

6. Install wheel (14), plate (7), flatwasher (9), nut (10), and new cotter pin (11).

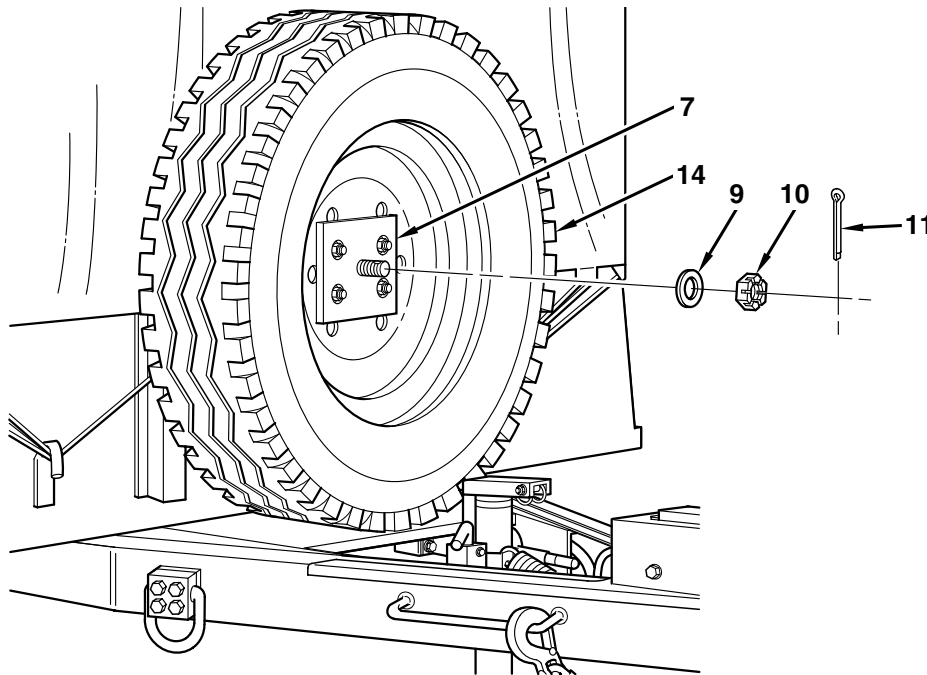

NOTE

- Have Organizational maintenance tighten wheel nuts to 385 lb-ft (522 N•m) as soon as possible.
- Flat tires should be stored inside cargo body until repaired.

END OF TASK

CHAPTER 6
ORGANIZATIONAL MAINTENANCE INSTRUCTIONS
FOR
M105A3 CARGO TRAILER

SERVICE UPON RECEIPT0021 00

THIS WP COVERS:Inspection, Servicing

INITIAL SETUP:**Maintenance Level**

Organizational

Materials/Parts

Fluid, Brake (Item 4, WP 0060 00)

Rags, Wiping (Item 9, WP 0060 00)

Solvent, Cleaning (Item 10, WP 0060 00)

References

WP 0017 00

WP 0018 00

WP 0022 00

WP 0023 00

GENERAL

When a new, used, or reconditioned trailer is first received, determine whether it has been properly prepared for service and is in condition to perform its mission. Follow the inspection instructions and servicing instructions specified below.

INSPECTION INSTRUCTIONS

1. Read and follow all instructions on DD Form 1397 attached to conspicuous part of trailer.
2. Remove all straps, plywood, tape, seals, and wrappings.

WARNING

Solvents can burn easily, can give off harmful vapors, and are harmful to skin and clothing. To avoid injury or death, keep away from open fire and use in a well-ventilated area. If solvent gets on skin or clothing, wash immediately with soap and water.

3. Remove rust-preventive compound from coated exterior parts of trailer using cleaning solvent and rags.
4. Inspect trailer for damaged incurred during shipment. Also check to see if equipment has been modified.
5. Check equipment against packing list to ensure that shipment is complete. Report any discrepancies in accordance with instructions in DA PAM 738-750.

SERVICING INSTRUCTIONS

1. Perform all Operator/Crew and Organizational Preventive Maintenance Checks and Services (PMCS) (WPs 0017 00 and 0022 00). Schedule next PMCS on DD Form 314.
2. Lubricate all lubrication points as described in Operator/Crew and Organizational lubrication charts (WPs 0018 00 and 0023 00) regardless of interval.

SERVICE UPON RECEIPT—Continued

0021 00

SERVICING INSTRUCTIONS—Continued

3. Report any problems on DA Form 2407.
4. Perform a break-in road test of 25 miles (40 km/h) at a maximum speed of 50 mph (80 km/h).

END OF TASK

**ORGANIZATIONAL PREVENTIVE MAINTENANCE
CHECKS AND SERVICES (PMCS)**

0022 00

THIS WP COVERS:

PMCS Procedures

INITIAL SETUP:

Maintenance Level

Organizational

Tools and Special Tools

Gage, Tire Tread Depth
Tool Kit, General Mechanic's

Materials/Parts

Rags, Wiping (Item 9, WP 0060 00)
Solvent, Cleaning (Item 10, WP 0060 00)

References

TM 9-2610-200-24	WP 0023 00	WP 0043 00
WP 0015 00	WP 0032 00	WP 0044 00
WP 0016 00	WP 0033 00	WP 0045 00
WP 0017 00	WP 0039 00	WP 0057 00
WP 0020 00		

GENERAL

To ensure that the trailer is ready for operation at all times, it must be inspected on a regular basis so that defects may be found before they result in serious damage, equipment failure, or injury to personnel. This section contains systematic instructions on inspections, adjustments, and corrections to be performed by Organizational maintenance.

While performing Preventive Maintenance Checks and Services (PMCS), read and follow all safety instructions in the Warning Summary at the front of this manual. Keep in mind all warnings.

SERVICE INTERVALS

Perform the PMCS procedures listed in Table 1 at the following intervals:

Perform "Semiannual" PMCS procedures twice each year.

Perform "Annual" PMCS procedures once each year.

REPORTING REPAIRS

Report all defects and corrective actions on DA Form 2404/DA Form 5988-E (electronic). If a serious problem is found, report it to your supervisor immediately.

GENERAL PMCS PROCEDURES

WARNING

Solvents can burn easily, can give off harmful vapors, and are harmful to skin and clothing. To avoid injury or death, keep away from open fire and use in a well-ventilated area. If solvent gets on skin or clothing, wash immediately with soap and water.

**ORGANIZATIONAL PREVENTIVE MAINTENANCE
CHECKS AND SERVICES (PMCS)—Continued**

0022 00

GENERAL PMCS PROCEDURES—Continued

Keep equipment clean. Dirt, oil, and debris may cover up a serious problem. Clean as you work and as needed. Use cleaning solvent on all metal surfaces. Use soap and water on rubber, plastic, and painted surfaces.

While performing specific PMCS procedures, inspect the following components:

Bolts, Nuts, and Screws. Ensure that they are not loose, missing, bent, or broken. Tighten any that are loose.

Welds. Inspect for gaps where parts are welded together. Report bad welds to your supervisor.

Electrical Conduit, Wires, and Connectors. Inspect for cracked or broken insulation, bare wires, and loose or broken connectors. Make repairs or replace as required.

Hose, Lines, and Fittings. Inspect for wear, damage, and leaks. Ensure that clamps and fittings are tight. If a leak originates from a loose fitting or connector, tighten it. If a component is broken or worn, correct the problem if authorized by the Maintenance Allocation Chart (MAC) (WP 0058 00). If not authorized, report it to your supervisor.

SPECIFIC PMCS PROCEDURES

Organizational PMCS is provided in Table 1. Always perform PMCS in the order listed. Once it becomes a habit, anything that is not right can be spotted in a minute. If anything wrong is discovered through PMCS, perform the appropriate troubleshooting task in WP 0015 00 or 0016 00. If any component or system is not serviceable, or if a given service does not correct the problem, notify your supervisor.

The PMCS procedures listed in Table 1 are to be performed at two intervals. Before performing PCMS, read all the checks required for the applicable interval and prepare the tools needed to make all checks. Have several clean rags handy. Perform ALL inspections at the applicable intervals.

The column headings in Table 1 are defined as follows:

Item No. The item number column of the PMCS table is to be used for reference. When completing DA Form 2404, include the item number for the check/service indicating a fault. Item numbers also appear in the order that you must do checks and services for the intervals listed.

Interval. Specifies the interval at which PMCS is to be performed.

Item To Be Inspected. This column tells you what item is to be inspected and how to do the required checks and services. Carefully follow these instructions. If you do not have the tools, or if the procedure tells you to, have Direct Support maintenance do the work.

Procedure. Provides the procedure that must be performed to check or service the item.

**ORGANIZATIONAL PREVENTIVE MAINTENANCE
CHECKS AND SERVICES (PMCS)—Continued**

0022 00

Table 1. Organizational PMCS.

ITEM NO.	INTERVAL	ITEM TO BE INSPECTED	PROCEDURE
<p>NOTE</p> <p>Perform Operator/Crew PMCS (WP 0017 00) prior to, or in conjunction with, Organizational PMCS if there is a delay between the daily operation of the equipment and the Organizational PMCS, or if the regular operator is not assisting/participating.</p>			
1	Semiannual	Brake Actuator Master Cylinder	Check fluid level. Fill to 3/4 full (WP 0023 00).
2	Semiannual	Wheels and Tires	<p>a. Inspect tires (including spare) for wear and damage. Check tread depth (TM 9-2610-200-24).</p> <p>b. Check wheel nuts for tightness. Torque nuts to 385 lb-ft (522 N•m) (WP 0020 00).</p>
3	Semiannual	Landing Gear	Inspect for bent or broken components (WP 0043 00).
4	Semiannual	Brakes	<p>a. Clean, inspect, and repair or replace internal brake parts as required (WP 0033 00).</p> <p>b. Clean out dirt, mud, and foreign material inside brake actuator casing.</p> <p>c. Adjust brakes (WP 0033 00).</p> <p>d. Check handbrake adjustment. Adjust as required (WP 0032 00).</p> <p>e. If possible, perform road test of trailer. Observe trailer for unusual or excessive noises that may indicate damage, looseness, defects, and deficient lubrication. Make several stops and observe for side pull, noise, chatter, or other unusual conditions.</p> <p>Inspect and repair brakes as required.</p>
5	Semiannual	Suspension	<p>a. Inspect springs for bent or cracked leaves, loose mounting, and worn components (WP 0044 00).</p> <p>b. Check axle U-bolt nuts for 223 lb-ft (302 N•m) torque.</p>

**ORGANIZATIONAL PREVENTIVE MAINTENANCE
CHECKS AND SERVICES (PMCS)—Continued**

0022 00

Table 1. Organizational PMCS—Continued.

ITEM NO.	INTERVAL	ITEM TO BE INSPECTED	PROCEDURE
6	Annual	Frame	Inspect for cracks, bent members, and broken welds.
7	Annual	Wheel Bearings	Clean wheel bearings and repack in accordance with lubrication instructions (WP 0023 00) and WP 0039 00.

END OF TASK

ORGANIZATIONAL LUBRICATION INSTRUCTIONS

0023 00

THIS WP COVERS:Lubrication Instructions

INITIAL SETUP:**Maintenance Level**

Organizational

Materials/Parts

Fluid, Brake (Item 4, WP 0060 00)

Grease (Item 5, WP 0060 00)

Oil, Lubrication (Item 7, WP 0060 00)

Oil, Lubrication (Item 8, WP 0060 00)

Solvent, Cleaning (Item 10, WP 0060 00)

References

FM 9-207

TM 9-214

GENERAL

This WP contains lubrication instructions, showing location, intervals, and proper materials for lubricating the trailer. Refer to the NOTES section of the chart for specific components to be lubricated. These instructions are mandatory.

The KEY lists lubricants to be used in all temperature ranges and shows the intervals.

DETAILED LUBRICATION INFORMATION

Clean lubrication points, grease fittings, and surrounding areas before applying lubricant.

Clean all lubrication points after lubricating to prevent accumulation of foreign matter.

Clean and lubricate bearings as specified in TM 9-214.

Maintain a record of vehicle lubrication and report any discrepancies noted during lubrication. Refer to DA PAM 738-750 for maintenance forms and procedures to record and report any findings.

SPECIFIC LUBRICATION INSTRUCTIONS

Keep all lubricants in closed containers and store in a clean, dry place away from extreme heat. Keep container covers clean and do not allow dust, dirt, or other foreign material to mix with lubricants. Keep all lubrication equipment clean and ready for use.

WARNING

Wipe excess lubricant from area of brakeshoe linings to avoid grease soaking linings. If brakeshoe linings become soaked, replace them. Failure to follow this warning may cause brakes to malfunction, resulting in serious injury or death.

Keep all external parts of equipment not requiring lubrication clean of lubricants.

Refer to FM 9-207 for lubrication instructions in cold weather.

SPECIFIC LUBRICATION INSTRUCTIONS—Continued

After operation in mud, sandy, or dusty conditions, clean and inspect all points of lubrication for fouled lubricants. Change lubricants as required.

LUBRICATION CHART

Intervals are based on normal operation. Adjust to compensate for abnormal and severe condition or contaminated lubricants. During inactive periods, intervals may be extended commensurate with adequate preservation.

WARNING

Solvents can burn easily, can give off harmful vapors, and are harmful to skin and clothing. To avoid injury or death, keep away from open fire and use in a well-ventilated area. If solvent gets on skin or clothing, wash immediately with soap and water.

Clean fittings before lubrication using cleaning solvent. Dry before lubricating.

The dotted leader lines indicate lubrication is required on both sides of the equipment.

Relubricate after washing or fording as necessary.

LUBRICATION CHART—Continued

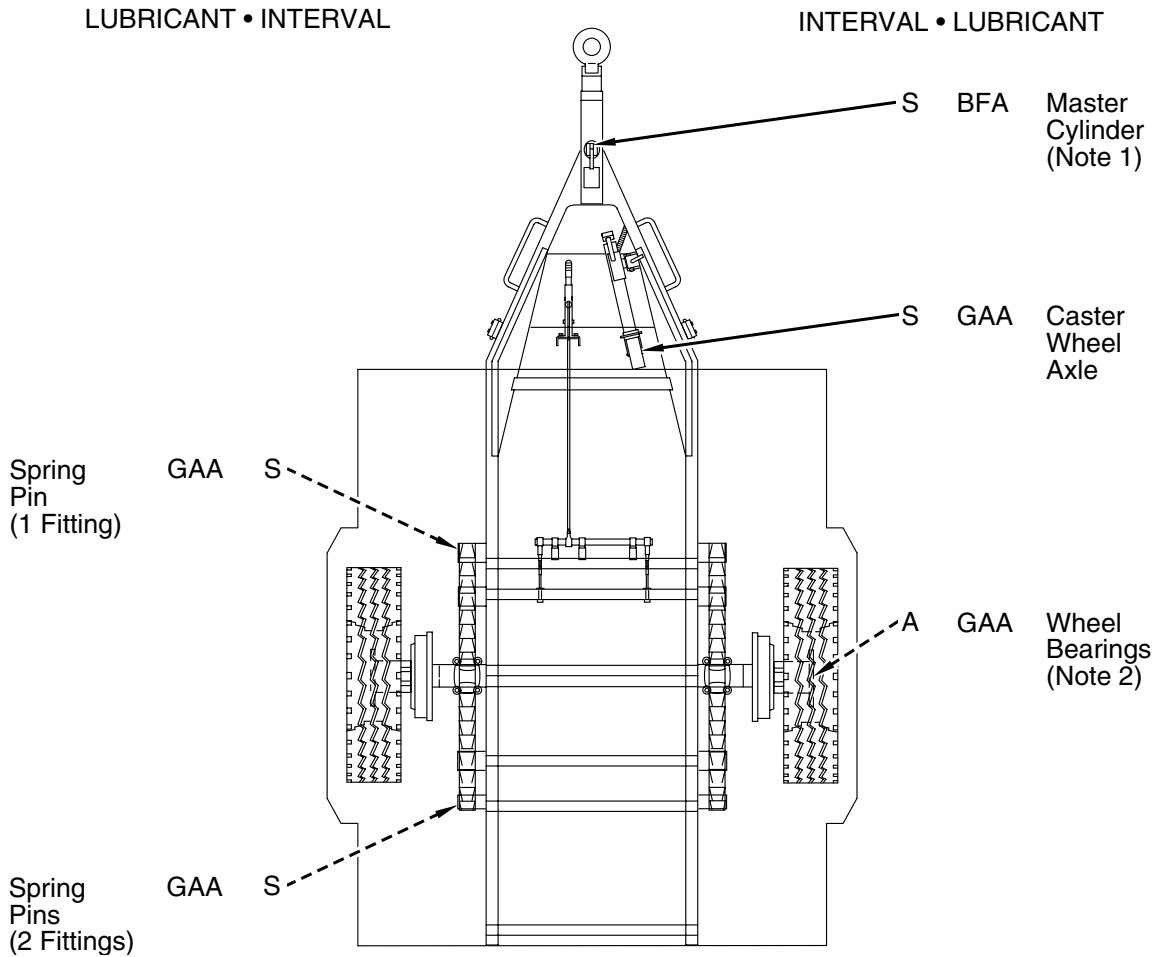

TOTAL MAN-HOURS*	
INTERVAL	MAN-HOURS
S	0.75
A	1.5

*The man-hour time specified is the time you need to do all services prescribed for a particular interval.

LUBRICATION CHART—Continued

—KEY—

LUBRICANTS	EXPECTED TEMPERATURES*			INTERVALS
	ABOVE +15°F (ABOVE -9°C)	+40°F to -15°F (+4°C to -26°C)	+40°F to -65°F (+4°C to -54°C)	
OE/HDO (MIL-L-2104) Lubricating Oil, Internal Combustion Engine, Tactical Service	OE/HDO-30	OE/HDO-30	—	S—Semiannual A—Annual
OEA (MIL-L-46167) Lubricating Oil, Internal Combustion Engine, Arctic	—	—	OEA	
BFS (MIL-B-46176) Brake Fluid, Silicone, Automotive	All Temperatures			
GAA (MIL-G-10924) Grease, Automotive and Artillery	All Temperatures			

*For Arctic operation, refer to FM 9-207.

CAUTION

Do not use any tool to tighten filler cap—finger-tighten only. Failure to follow this caution could result in damage to equipment.

NOTES:

1. **Brake Actuator Master Cylinder.** Every month, check fluid level. Add fluid to 3/4 full.
2. **Wheel Bearings.** Every 12 months, remove, clean, and pack with GAA. Refer to TM 9-214.

END OF TASK

GENERAL MAINTENANCE INSTRUCTIONS

0024 00

THIS WP COVERS:

Work Safety, Cleaning Instructions, Inspection Instructions, Repair Instructions, Tagging Wires and Hoses

INITIAL SETUP:

Maintenance Level

Organizational

Tools and Special Tools

Tool Kit, General Mechanic's

Materials/Parts

Brush, Scrub (Item 1, WP 0060 00)
 Cloth, Abrasive (Item 2, WP 0060 00)
 Rags, Wiping (Item 9, WP 0060 00)
 Solvent, Cleaning (Item 10, WP 0060 00)

References

TM 9-214
 TM 9-247
 WP 0037 00

GENERAL

These general maintenance instructions contain general shop practices and specific methods you must be familiar with to properly maintain your trailer. You should read and understand these practices and methods before performing any Organizational tasks.

Before beginning a task, find out how much repair, modification, or replacement is needed to fix the equipment. Sometimes the reason for equipment failure can be seen right away, and complete teardown is not necessary. Disassemble equipment only as far as necessary to repair or replace damaged or broken parts.

The following "Initial Setup" information applies to all procedures:

1. Resources are not listed unless they apply to the procedure.
2. Personnel are listed only if more than one technician is required to complete the task. If "Personnel Required" is not listed, one mechanic can complete the task.

All tags and forms attached to equipment must be checked to learn the reason for equipment's removal from service. Modification Work Orders (MWOs) and technical bulletins must also be checked for equipment changes and updates.

In some cases, a part may be damaged by removal. If the part appears to be good, and other parts behind it are not defective, leave it on and continue with the procedure. Here are a few simple rules:

1. Do not remove dowel pins or studs unless loose, bent, broken, or otherwise damaged.
2. Do not remove bearings or bushings unless damaged. If you need to remove them to access parts behind, pull bearings and bushings out carefully.
3. Replace all gaskets, seals, lockwashers, cotter pins, preformed packings, and other locking hardware.

WORK SAFETY

Observe all warnings and cautions. Always use power tools carefully.

WORK SAFETY—Continued

Protect yourself against injury. Wear protective gear such as safety goggles or lenses, safety shoes, rubber apron, and gloves.

When lifting heavy parts, have someone help you. Ensure that lifting/stabilizing equipment is working properly, is suitable for the assigned task, and is secure against slipping.

All maintenance should be performed with:

1. Trailer parking brake engaged
2. Towing vehicle in neutral with parking brake engaged, if attached
3. Towing vehicle engine stopped, if attached

CLEANING INSTRUCTIONS**WARNING**

Improper cleaning methods and use of unauthorized cleaning liquids or solvents can injure personnel and damage equipment. To prevent this, refer to TM 9-247 for further instructions.

General

Cleaning instructions will be the same for a majority of parts and components that make up the trailer. The following should apply to all cleaning operations:

1. Clean all parts before inspection, after repair, and before assembly.
2. Keep hands free of grease which can collect dust, dirt, and grit.
3. After cleaning, all parts should be covered or wrapped to protect them from dust and dirt. Parts that are subject to rust should be lightly oiled.

Steam Cleaning

1. Before steam cleaning exterior of trailer, protect all electrical equipment that could be damaged by steam or moisture.
2. Place disassembled parts in a suitable container to steam clean. Parts that are subject to rust should be dried and lightly oiled after cleaning.

Castings, Forgings, and Machined Metal Parts**WARNING**

Solvents can burn easily, can give off harmful vapors, and are harmful to skin and clothing. To avoid injury or death, keep away from open fire and use in a well-ventilated area. If solvent gets on skin or clothing, wash immediately with soap and water.

Clean inner and outer surfaces with cleaning solvent.

Remove grease and accumulated deposits with a stiff bristle brush.

WARNING

Compressed air used for cleaning or drying purposes, or for clearing restrictions, should never exceed 30 psi (207 kPa). Wear protective clothing (goggles/shield, gloves, etc.) and use caution to avoid injury to personnel.

Clear all threaded holes with compressed air to remove dirt and cleaning fluids.

Oil Seals, Electrical Cables, and Flexible Hoses**CAUTION**

Do not wash oil seals, electrical harnesses, and flexible hoses with dry-cleaning solvent or mineral spirits. Serious damage or destruction of material would result.

Wash electrical cables and flexible hoses with a solution of soap and water and wipe dry.

Bearings

Clean bearings in accordance with TM 9-214.

INSPECTION INSTRUCTIONS**NOTE**

All damaged areas should be marked for repair or replacement.

All components and parts must be carefully checked to determine if they are serviceable for use, can be repaired, or must be scrapped.

GENERAL MAINTENANCE INSTRUCTIONS—Continued

0024 00

INSPECTION INSTRUCTIONS—Continued

Inspect drilled and tapped (threaded) holes for the following:

1. Wear, distortion, cracks, and any other damage in or around holes for wear, distortion, cracks, and any other damage
2. Threaded areas for wear, distortion (stretching), and evidence of cross-threading

Inspect metal lines, flexible lines (hoses), and metal fittings for the following:

1. Metal lines for sharp kinks, cracks, bad bends, and dents
2. Flexible lines for fraying, evidence of leakage, and loose metal fittings or connectors
3. Metal fittings and connectors for thread damage and worn or rounded hex heads

Inspect castings, forgings, and machined metal parts for the following:

1. Machined surfaces for nicks, burrs, raised metal, wear, and other damage
2. Inner and outer surfaces for breaks and cracks

Inspect bearings in accordance with TM 9-214.

REPAIR INSTRUCTIONS

Any repair procedure peculiar to a specific part or component is covered in the WP relating to that item. After repair, clean all parts thoroughly to prevent dirt, metal chips, or other foreign material from entering any working parts.

Repair casting, forgings, and machined metal parts using the following instructions:

1. Repair minor cracked casting or forgings.

WARNING

Solvents can burn easily, can give off harmful vapors, and are harmful to skin and clothing. To avoid injury or death, keep away from open fire and use in a well-ventilated area. If solvent gets on skin or clothing, wash immediately with soap and water.

2. Repair minor damage to machined surfaces with a fine mill file or an abrasive cloth dipped in cleaning solvent.
3. Replace any deeply nicked machined surface that could affect the assembly operation.
4. Repair minor damage to threaded capscrew holes with thread tap of same size to prevent cutting oversize.

Refer to WP 0037 00 for maintenance on metal lines, flexible lines (hoses), and metal fittings.

REPAIR INSTRUCTIONS—Continued

After repair, clean all parts thoroughly to prevent dirt, metal chips, or other foreign material from entering any working parts.

TAGGING WIRES AND HOSES

As soon as the first wire, hose, or tube is disconnected, write number “1” on two tags. Secure one tag to the wire, hose, or tube and the other tag to the terminal, nipple, or fitting. After disconnecting the second wire, hose, or tube, write number “2” on two tags. Secure one tag to the wire, hose, or tube, and the second tag to the terminal, nipple, or fitting. Do the same for all wires, hoses, and tubes.

Note which numbers you used, in pencil, on art in this manual. This will help you to accurately re-tag, if tags are removed to perform cleaning and maintenance work.

Remove all tags when finished.

END OF TASK

ELECTRICAL SCHEMATIC

0025 00

THIS WP COVERS:
Electrical Schematic

INITIAL SETUP:
Maintenance Level
Organizational

References
WP 0002 00
WP 0028 00

M105A3 TRAILER ELECTRICAL SCHEMATIC

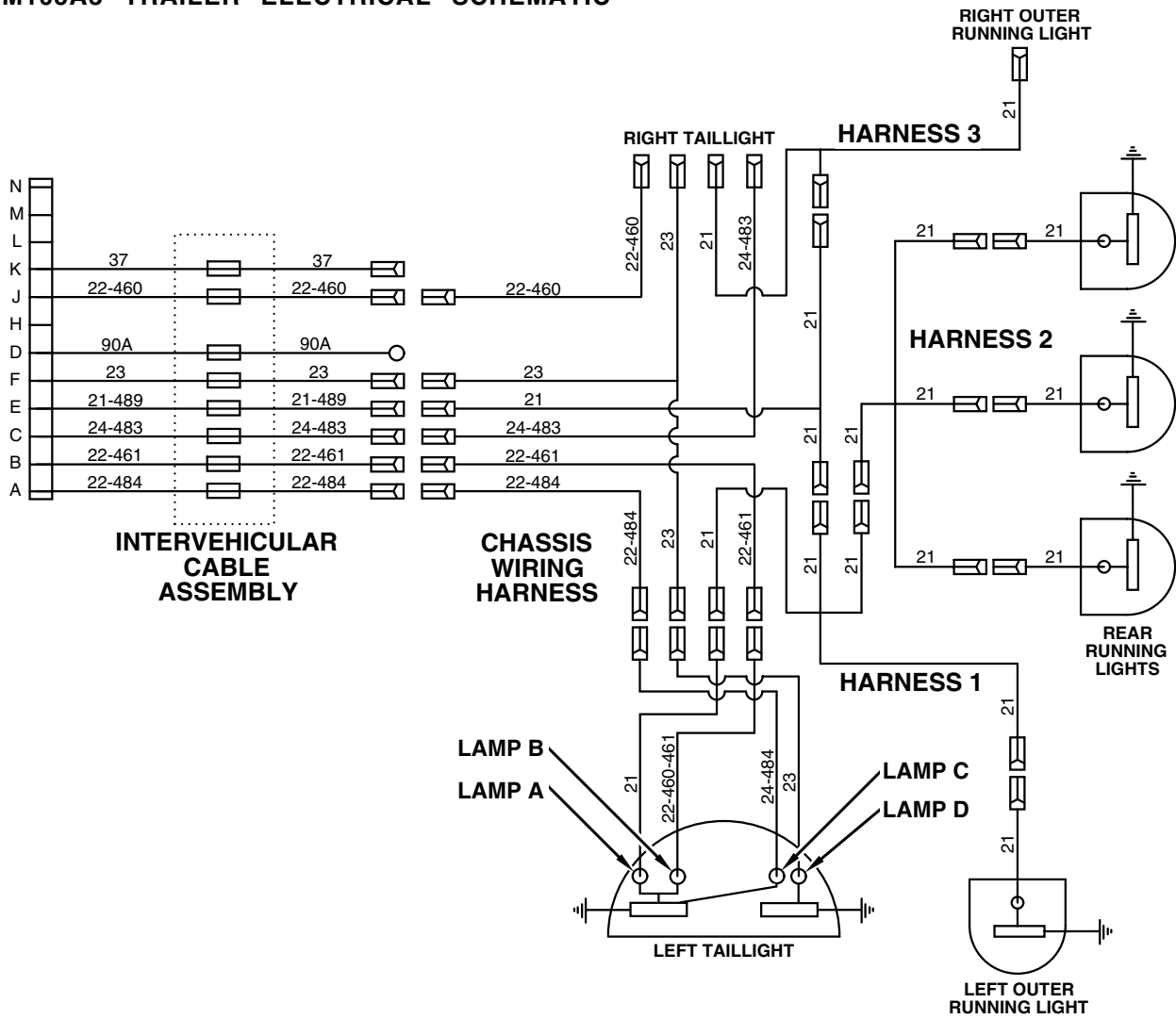

NOTE

Refer to page 0002 00-5 for the locator view of these cables, and to WP 0028 00 for removal/installation views.

COMPOSITE LIGHT MAINTENANCE

0026 00

THIS WP COVERS:

Lamp/LED Replacement, Composite Light Removal, Composite Light Installation

INITIAL SETUP:

Maintenance Level

Organizational

Tools and Special Tools

Tool Kit, General Mechanic's

Materials/Parts

Marker Tags (as required) (Item 6,
WP 0060 00)
Lamps (4) (Items 1 & 2, WP 0061 00)
LEDs (4) (Items 33 & 34, WP 0061 00)
Lockwashers (4) (Item 18, WP 0061 00)

References

WP 0030 00

Equipment Conditions

Intervehicular Cable Assembly Disconnected
From Towing Vehicle (page 0007 00-5)

LAMP/LED REPLACEMENT

1. Loosen six screws (1) and remove lens (2) from body (4).
2. Inspect preformed packing (3) for damage. If damaged, remove and discard.
3. Remove two lamps (5) and LEDs (6) by pushing in and turning counterclockwise.
4. Install two new lamps (5) and LEDs (6) by pushing in and turning clockwise.
5. If removed, install new preformed packing (3) in lens (2).
6. Install lens (2) on body (4) and tighten six screws (1).

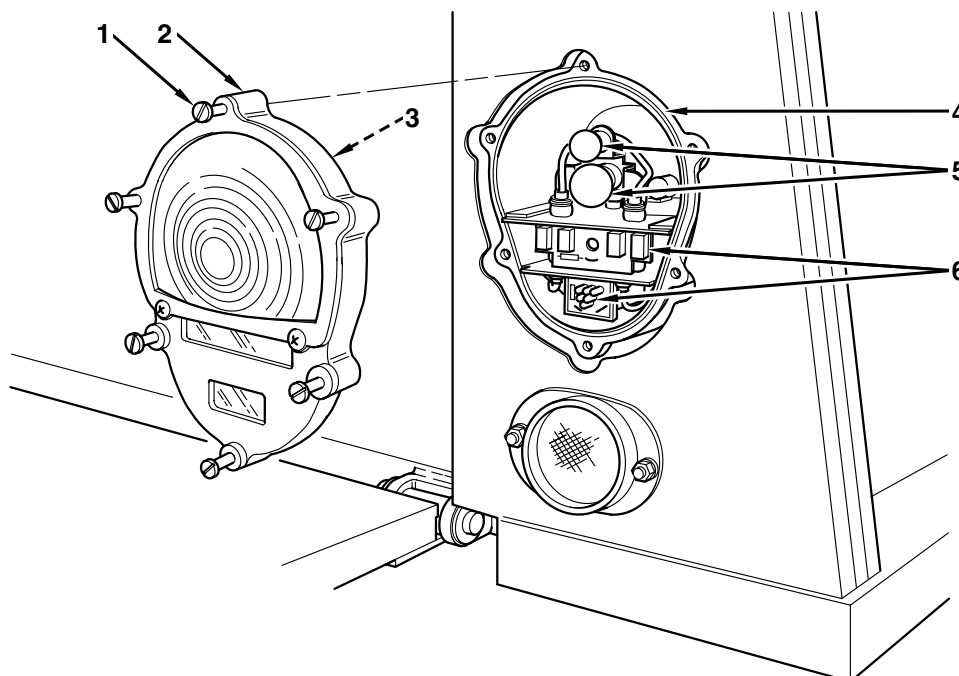

COMPOSITE LIGHT REMOVAL

NOTE

Right and left composite lights (10) are removed the same way. This procedure covers one composite light.

1. Remove two plastic plugs (7), screws (8), and lockwashers (9). Discard lockwashers.

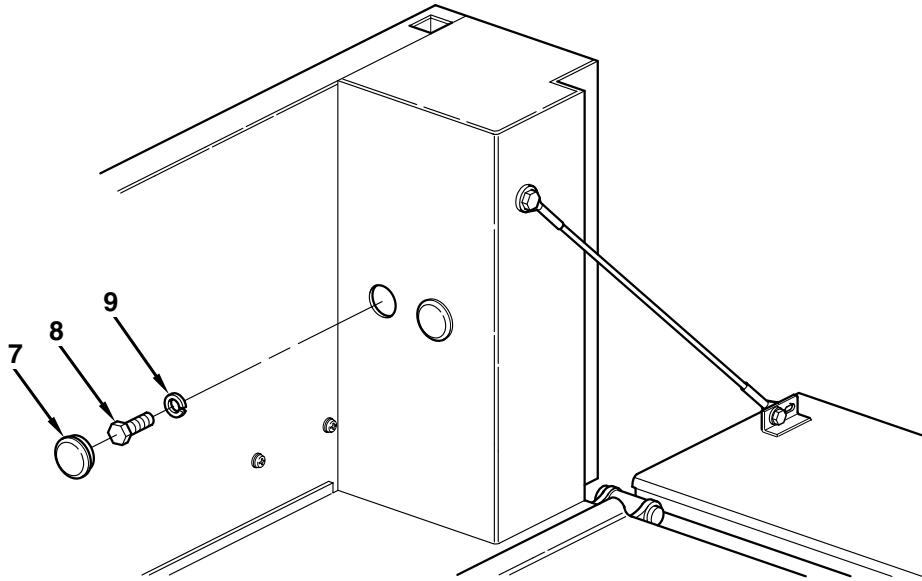

2. Tag wires for installation if identification bands are missing or not legible (WP 0030 00).
3. Pull out composite light (10) from housing (11), disconnect four plug connectors (12), and remove composite light.

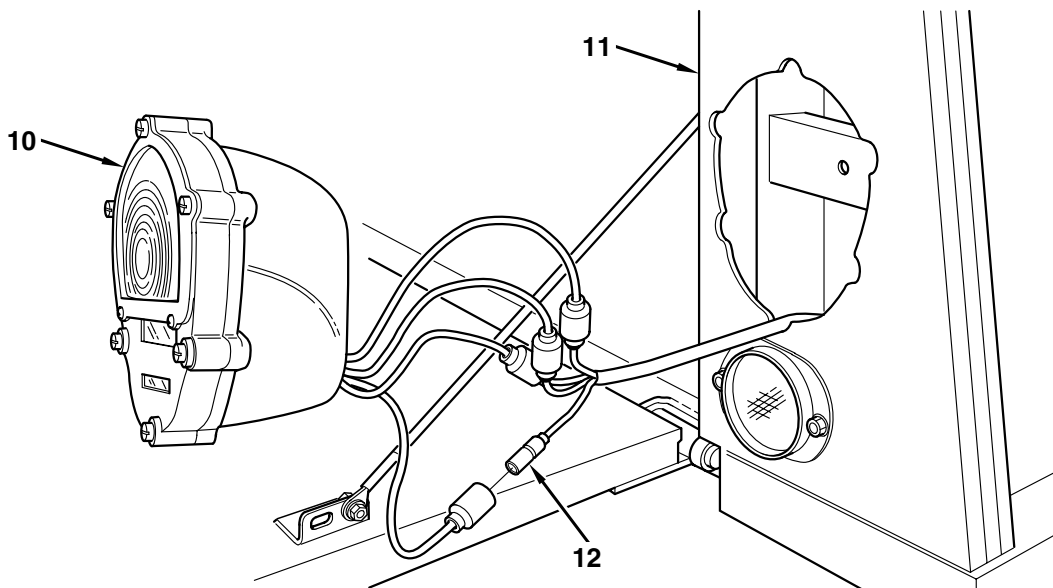

COMPOSITE LIGHT INSTALLATION

NOTE

Right and left composite lights (10) are installed the same way. This procedure covers one composite light.

1. Connect four plug connectors (12) and remove tags if used.
2. Position composite light (10) in housing (11).

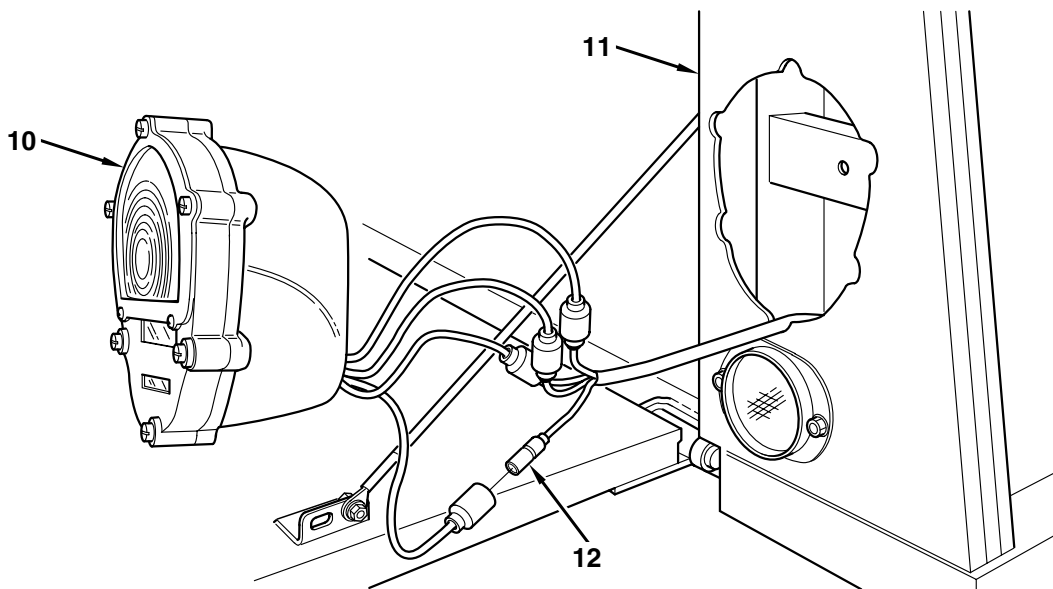

3. Install two new lockwashers (9), screws (8), and plastic plugs (7).

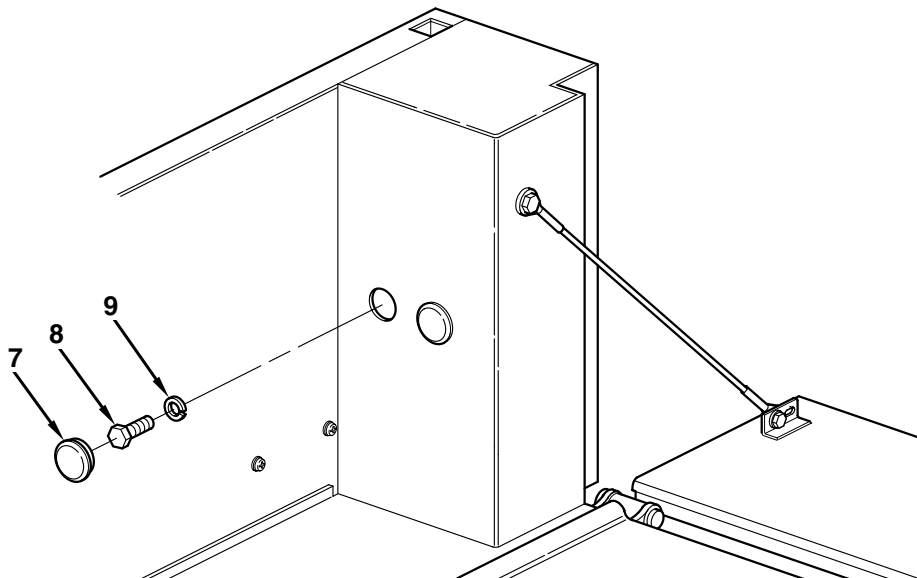

COMPOSITE LIGHT MAINTENANCE—Continued

0026 00

FOLLOW-ON TASKS

1. Connect intervehicular cable assembly to towing vehicle (page 0007 00-5).
2. Check operation of light.

END OF TASK

RUNNING LIGHT MAINTENANCE

0027 00

THIS WP COVERS:

Lamp Replacement, Running Light Removal, Running Light Installation

INITIAL SETUP:

Maintenance Level

Organizational

Tools and Special Tools

Tool Kit, General Mechanic's

Materials/Parts

Marker Tags (as required) (Item 6,
WP 0060 00)
Lamps (5) (Item 35, WP 0061 00)
Lockwashers (20) (Items 7 & 10, WP 0061 00))

Equipment Conditions

Composite Lights Removed (WP 0026 00)
Intervehicular Cable Assembly Disconnected
From Towing Vehicle (page 0007 00-5)

LAMP REPLACEMENT

1. Remove two screws (2) and lens (1).
2. Remove lamp (3) by pushing in and turning counterclockwise.
3. Install new lamp (3) by pushing in and turning clockwise.
4. Install lens (1) and two screws (2).

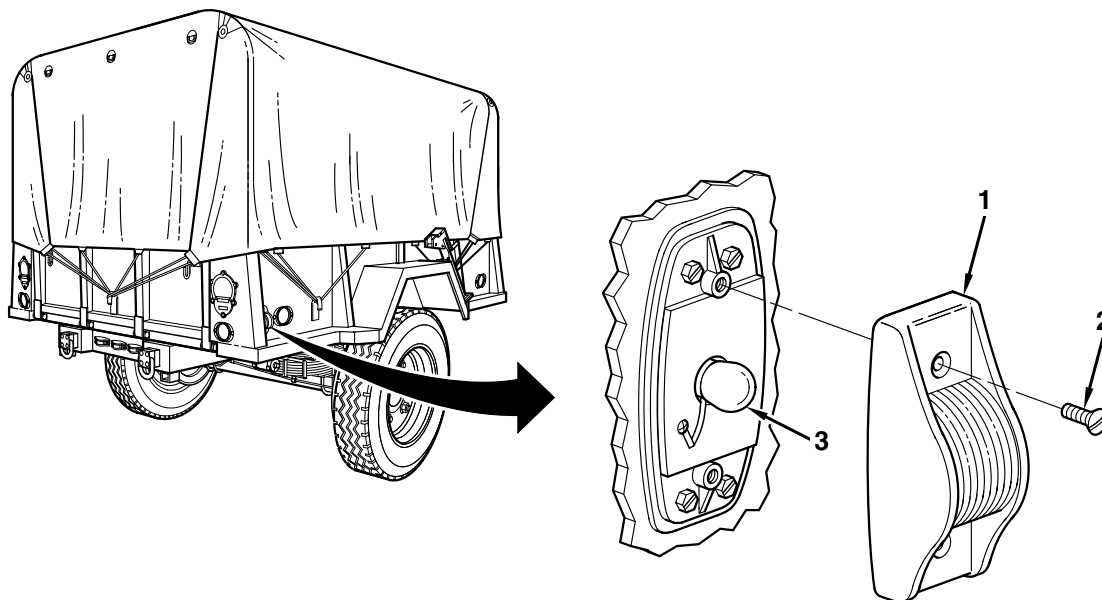

RUNNING LIGHT REMOVAL

NOTE

All five running lights are removed the same way. This procedure covers one running light.

1. Disconnect plug connector (9).
2. Remove two screws (2), lens (1), and bulb (3).
3. Remove four nuts (8), lockwashers (7), screws (6), running light base (5), and gasket (4). Inspect gasket and discard if damaged. Discard lockwashers.

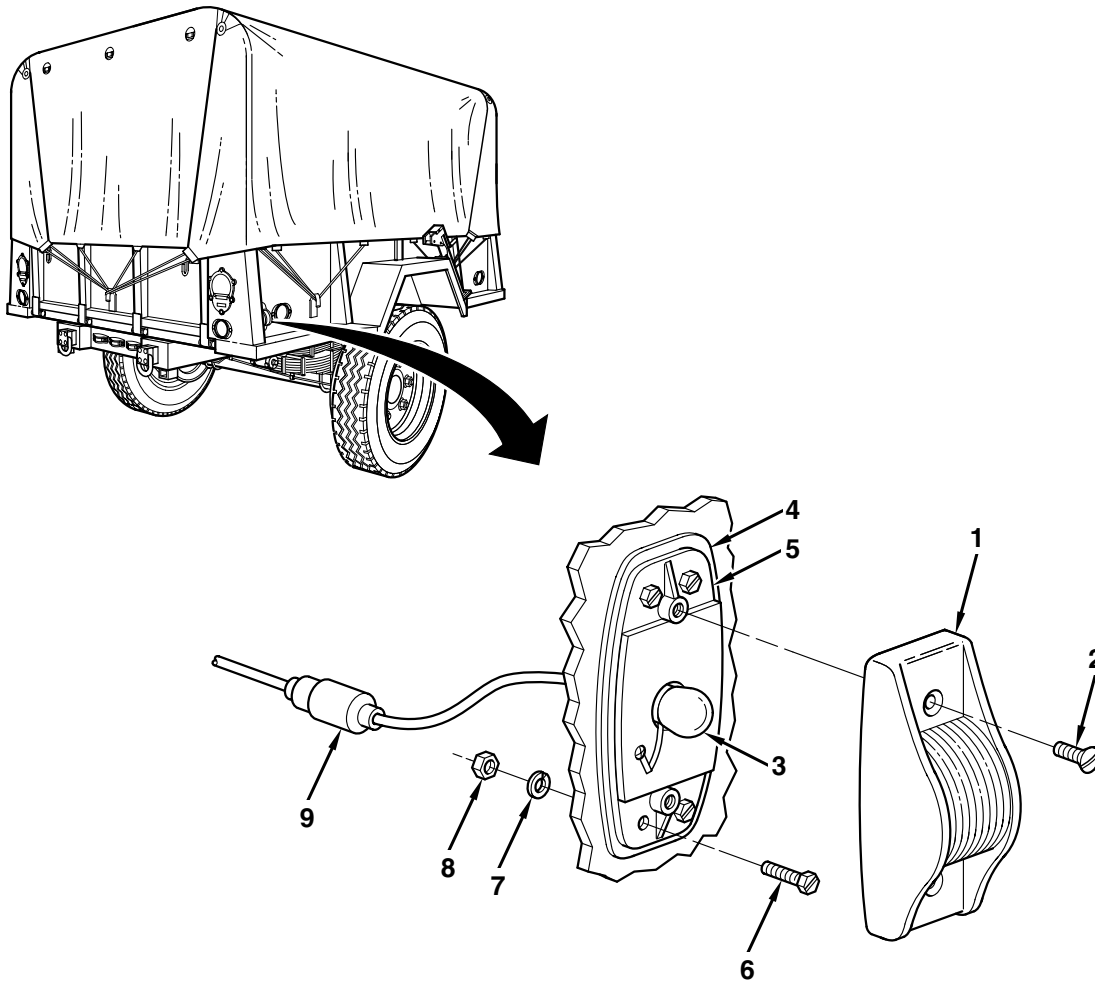

RUNNING LIGHT INSTALLATION

NOTE

All running lights are installed the same way. This procedure covers one running light.

1. Install gasket (4) or new gasket if old one was discarded, running light base (5), four screws (6), new lockwashers (7), and nuts (8).
2. Install bulb (3), lens (1), and two screws (2).
3. Connect plug connector (9).

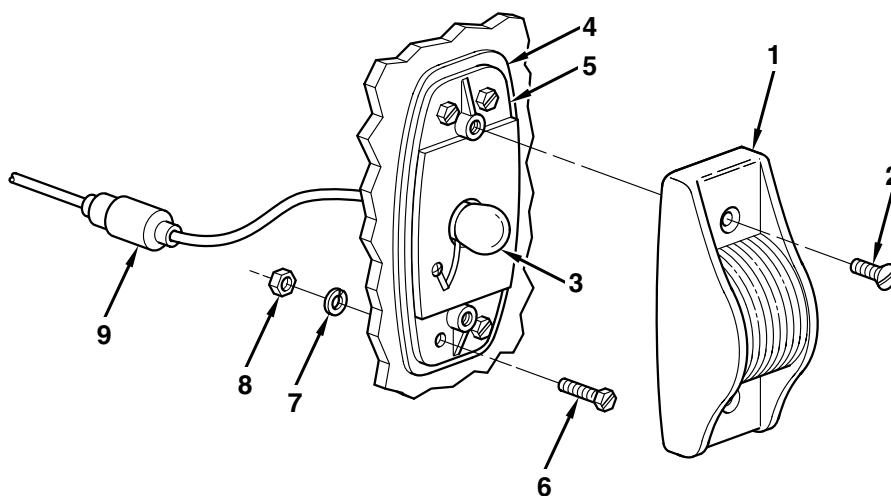

FOLLOW-ON TASKS

1. Connect intervehicular cable assembly to towing vehicle (page 0007 00-5).
2. Check operation of light.

END OF TASK

CHASSIS WIRING HARNESS MAINTENANCE

0028 00

THIS WP COVERS:

Removal, Inspection, Installation

INITIAL SETUP:

Maintenance Level

Organizational

Tools and Special Tools

Multimeter

Tool Kit, General Mechanic's

Materials/Parts

Marker Tags (as required) (Item 6,
WP 0060 00)

Lockwashers (12) (Item 15, WP 0061 00)

References

WP 0002 00

WP 0025 00

WP 0030 00

Equipment Conditions

Composite Lights Removed (WP 0026 00)

Intervehicular Cable Assembly Disconnected

From Towing Vehicle (page 0007 00-5)

Running Lights Disconnected (WP 0027 00)

WARNING

Make sure all electrical power is disconnected before performing any maintenance on electrical system. Serious injury or death may result if proper precautions are not taken.

NOTE

Refer to page 0002 00-5 for the locator view of these cables, and to page 0025 00-1 for the schematic.

REMOVAL

1. Remove nut (1), lockwasher (2), screw (4), and clamp (3) from intervehicular cable assembly (5). Discard lockwasher.
2. Pull back chassis wiring harness (6) until plug connectors (7) are exposed.
3. Tag wires for installation if identification bands are missing or not legible (WP 0030 00).
4. Disconnect six plug connectors (8).
5. Remove 11 nuts (1), lockwashers (2), screws (4), clamps (3), and chassis wiring harness (6). Discard lockwashers.
6. Remove four grommets (7).

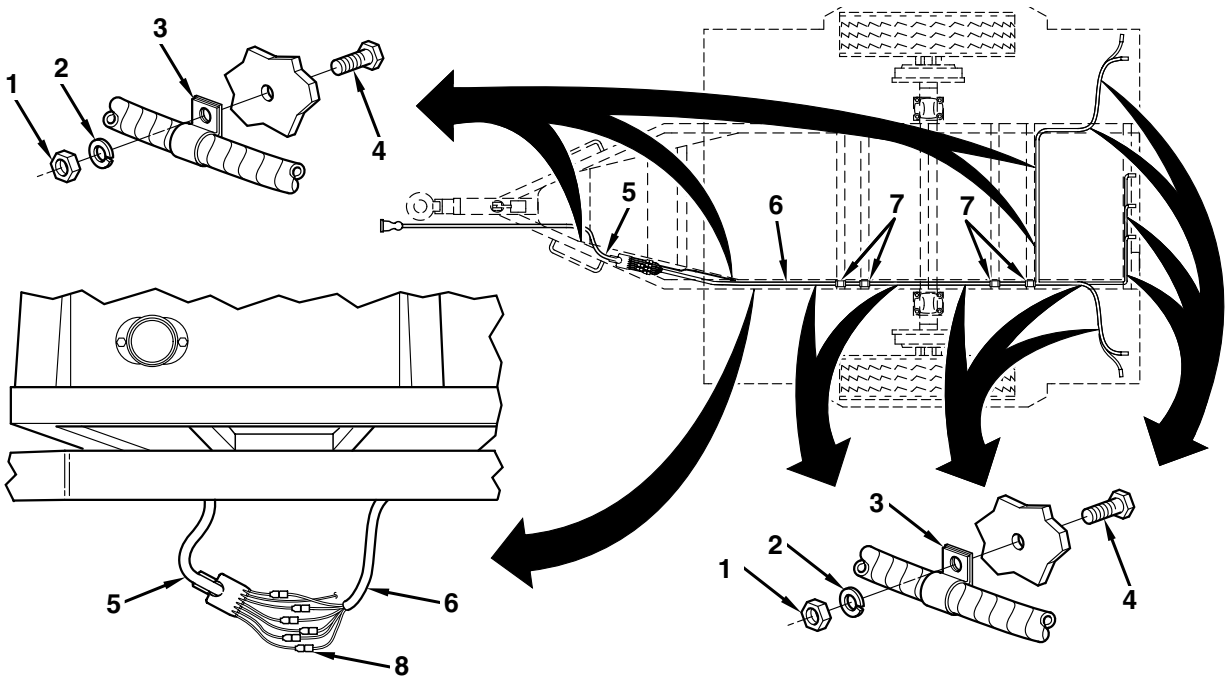

INSPECTION

1. Inspect for cracks, breaks, or other damage.
2. Replace defective parts.

INSTALLATION

1. Install four grommets (7).
2. Position chassis wiring harness (6) and install 11 clamps (3), screws (4), new lockwashers (2), and nuts (1).

INSTALLATION—Continued

3. Connect six plug connectors (8) to intervehicular cable assembly (5).
4. Remove tags if used.
5. Pull forward intervehicular cable assembly (5) until plug connectors (8) are inside frame and there is 60 ± 0.5 in. (152 ± 1 cm) of cable exposed from main plug on end to point where cable is clamped.
6. Install clamp (3), screw (4), new lockwasher (2), and nut (1) on intervehicular cable assembly (5).

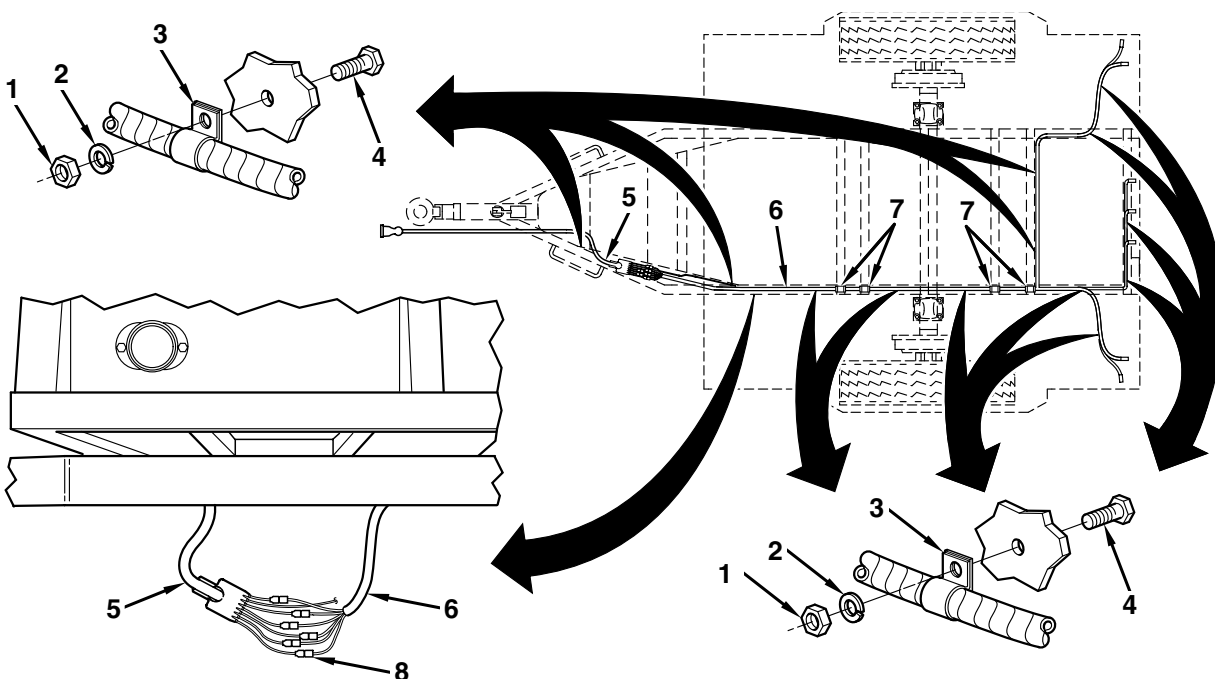

FOLLOW-ON TASKS

1. Install composite lights (WP 0026 00).
2. Connect running lights (WP 0027 00).
3. Connect intervehicular cable assembly to towing vehicle (page 0007 00-5).
4. Check operation of lights.

END OF TASK

INTERVEHICULAR CABLE ASSEMBLY MAINTENANCE

0029 00

THIS WP COVERS:

Removal, Inspection, Installation

INITIAL SETUP:

Maintenance Level

Organizational

Tools and Special Tools

Tool Kit, General Mechanic's

Materials/Parts

Marker Tags (as required) (Item 6,
WP 0060 00)

Lockwashers (2) (Item 15, WP 0061 00)

References

WP 0030 00

Equipment Conditions

Intervehicular Cable Assembly Disconnected From Towing Vehicle (page 0007 00-5)

WARNING

Make sure all electrical power is disconnected before performing any maintenance on electrical system. Serious injury or death may result if proper precautions are not taken.

REMOVAL

1. Remove nut (5), lockwasher (4), screw (1), and clamp (3) from intervehicular cable assembly (2). Discard lockwasher.
2. Remove nut (6), lockwasher (7), screw (10), clamp (9), and disconnect ground wire (8). Discard lockwasher.
3. Pull back chassis wiring harness (11) until plug connectors (12) are exposed.
4. Tag wires for installation if identification bands are missing or not legible (WP 0030 00).
5. Disconnect six plug connectors (12).
6. Remove intervehicular cable assembly (2) by pulling out from front.

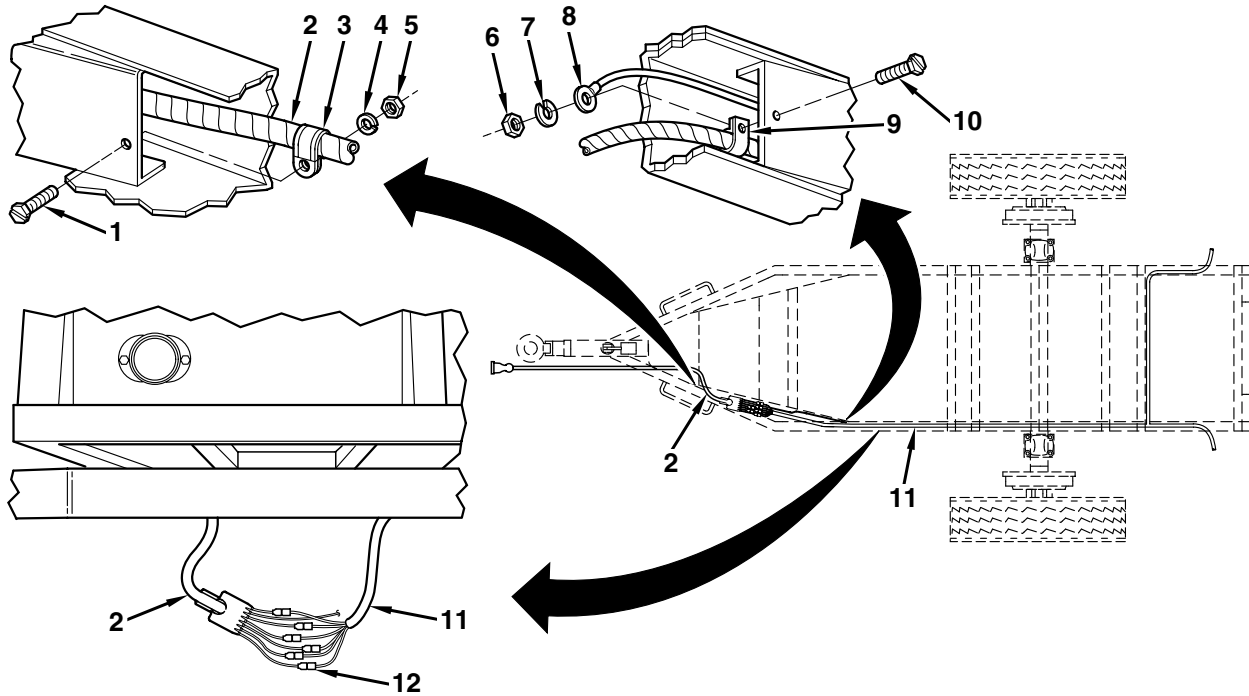

INSPECTION

1. Inspect for cracks, breaks, or other damage.
2. Replace defective parts.

INSTALLATION

1. Slide intervehicular cable assembly (2) inside frame from front until plug connectors (12) are exposed.
2. Connect six plug connectors (12) to chassis wiring harness (11).
3. Remove tags if used.
4. Pull forward intervehicular cable assembly (2) until plug connectors (12) are inside frame and there is 60 ± 0.5 in. (152 ± 1 cm) of cable exposed from main plug on end to point where cable is clamped.
5. Install ground wire (8), clamp (9), screw (10), new lockwasher (7), and nut (6).
6. Install clamp (3), screw (1), new lockwasher (4), and nut (5) on intervehicular cable assembly (2).

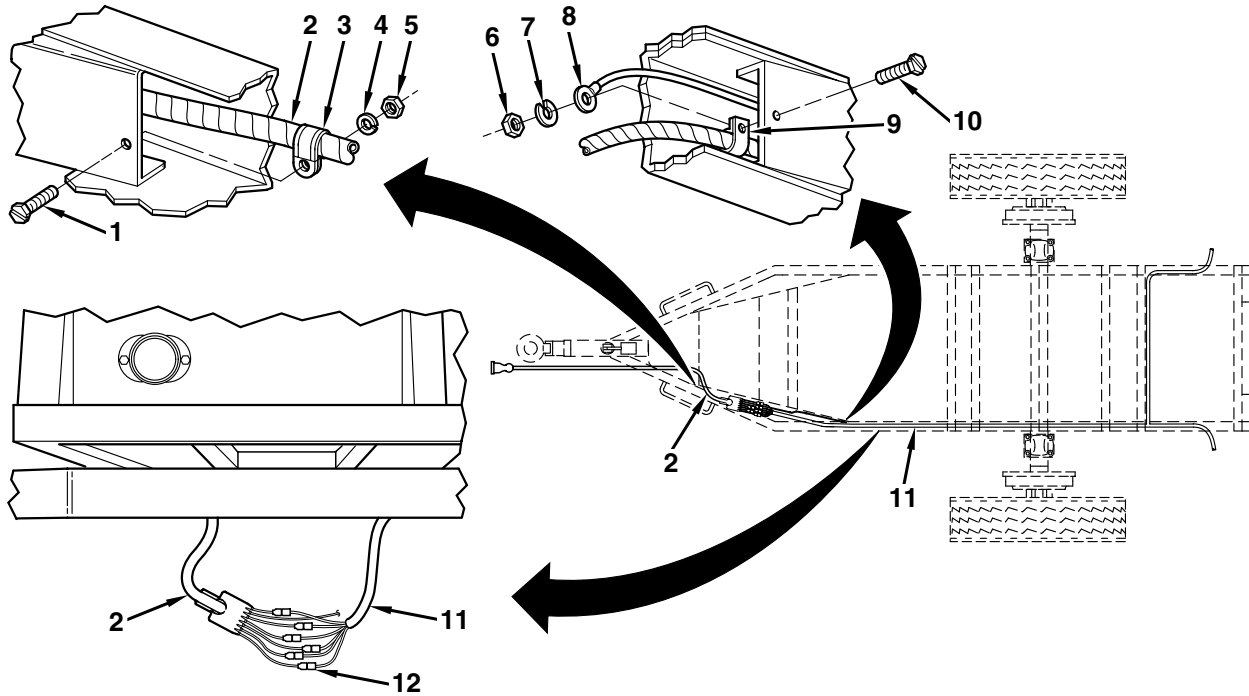

FOLLOW-ON TASKS

1. Connect intervehicular cable assembly to towing vehicle (page 0007 00-5).
2. Check operation of lights.

END OF TASK

WIRING HARNESS AND CABLE ASSEMBLY REPAIR

0030 00

THIS WP COVERS:

Identification Band Replacement, Terminal Replacement, Male Connector Repair, Female Connector Repair

INITIAL SETUP:

Maintenance Level

Organizational

Materials/Parts

Contacts (as required)
 Identification Bands (as required)
 Terminals (as required)

Tools and Special Tools

Electric Etcher
 Terminal Kit
 Tool Kit, Electrical Connector
 Tool Kit, General Mechanic's

Equipment Conditions

Intervehicular Cable Assembly Disconnected
 From Towing Vehicle (WP 0007 00)

IDENTIFICATION BAND REPLACEMENT

1. Remove identification band (2) from wire lead (1) and discard.
2. Mark new identification band (2) with proper identification number.
3. Position new identification band (2) on wire lead (1) and bend tabs over wire lead.

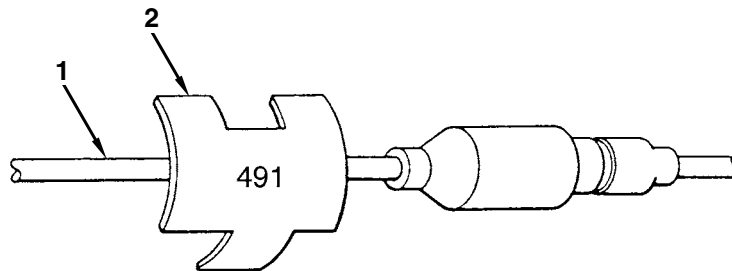

TERMINAL REPLACEMENT

1. Cut terminal (3) off wire lead (4) and discard terminal.
2. Strip insulation off wire lead (4) equal to depth of new terminal (3).
3. Position new terminal (3) on wire lead (4). Crimp terminal.

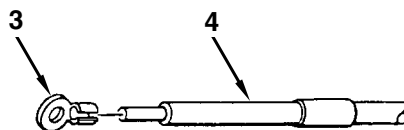

MALE CONNECTOR REPAIR

1. Slide shell (8) back and remove washer (7) from wire lead (6). Cut contact (5) from wire lead and discard contact. Remove shell.
2. Strip insulation off wire lead (6) equal to depth of new contact (5).
3. Slide shell (8) on wire lead (6).
4. Position new contact (5) on wire lead (6) and crimp new contact.
5. Position washer (7) on wire lead (6). Slide shell (8) over washer and contact (5).

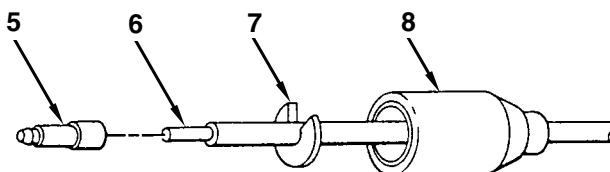
**FEMALE CONNECTOR REPAIR**

1. Slide connector (12) and insulator (11) back and cut terminal (9) from wire lead (10). Discard terminal.
2. Remove insulator (11) and connector (12) from wire lead (10).
3. Strip insulation off wire lead (10) equal to depth of new terminal (9).
4. Slide connector (12) and insulator (11) on wire lead (10).
5. Position new terminal (9) on wire lead (10) and crimp new terminal.
6. Slide insulator (11) and connector (12) over terminal (9).

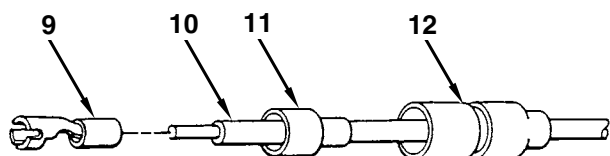
**FOLLOW-ON TASK**

Connect intervehicular cable assembly to towing vehicle (WP 0007 00).

END OF TASK

HANDBRAKE LEVER REPLACEMENT

0031 00

THIS WP COVERS:

Removal, Installation

INITIAL SETUP:

Maintenance Level

Organizational

Tools and Special Tools

Tool Kit, General Mechanic's

Materials/Parts

Cotter Pin (Item 4, WP 0061 00)

Lockwashers (4) (Item 17, WP 0061 00)

References

WP 0019 00

REMOVAL

WARNING

If trailer is not coupled to towing vehicle, ensure that landing gear is lowered and locked and wheels are securely chocked. Failure to follow this warning may cause trailer to roll, resulting in injury to personnel or damage to equipment.

1. Remove cotter pin (10), flatwasher (9), clevis pin (2), and disconnect yoke (4) from handbrake lever (1). Discard cotter pin.
2. Remove four nuts (5), lockwashers (6), eight flatwashers (7), four screws (8), and handbrake lever (1) from frame assembly (3). Discard lockwashers.

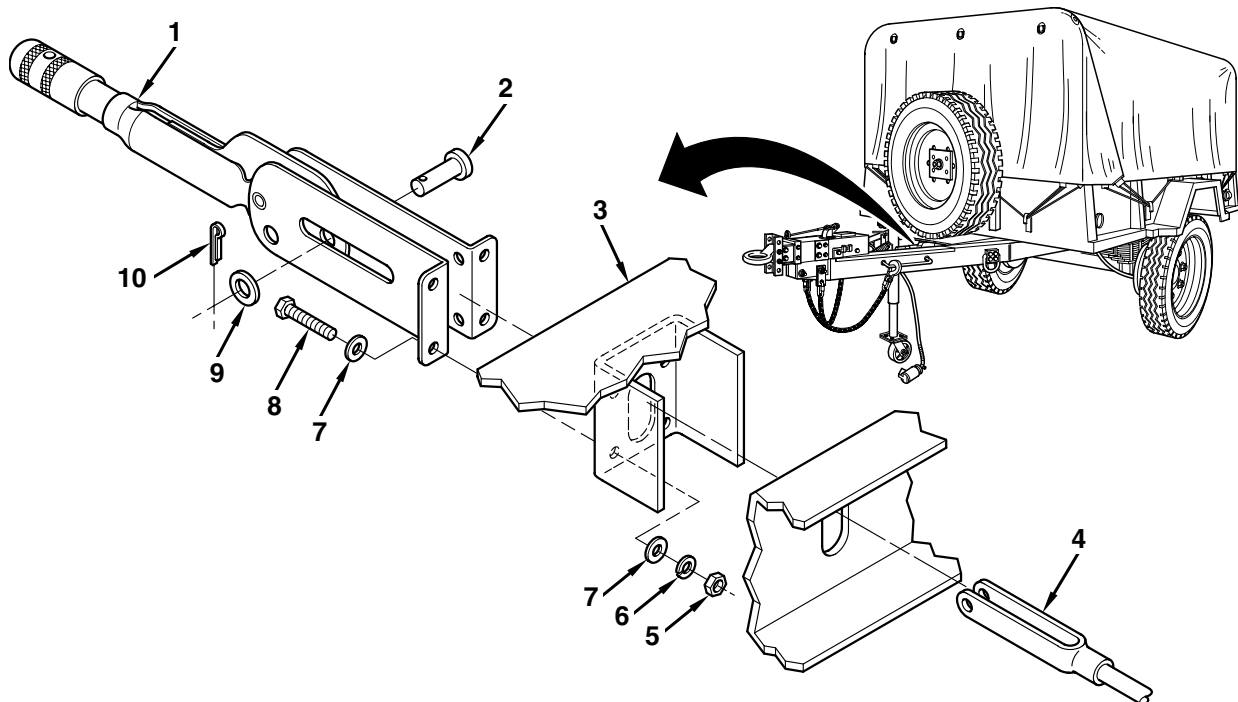

INSTALLATION

WARNING

If trailer is not coupled to towing vehicle, ensure that landing gear is lowered and locked and wheels are securely chocked. Failure to follow this warning may cause trailer to roll, resulting in injury to personnel or damage to equipment.

1. Install handbrake lever (1) on frame assembly (3) with four screws (8), eight flatwashers (7), four new lockwashers (6), and nuts (5).
2. Connect yoke (4) to handbrake lever (1) with clevis pin (2), flatwasher (9), and new cotter pin (10).

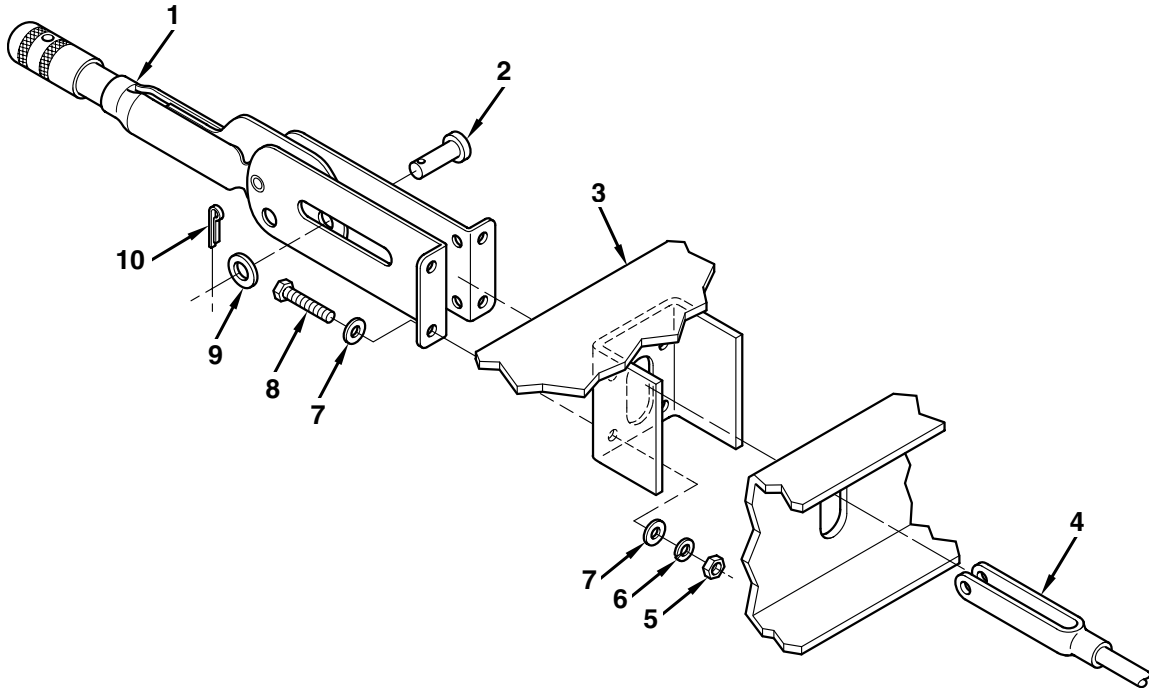

FOLLOW-ON TASK

Adjust handbrake lever (WP 0019 00).

END OF TASK

HANDBRAKE LINKAGE AND CABLES MAINTENANCE

0032 00

THIS WP COVERS:

Removal, Installation, Adjustment

INITIAL SETUP:

Maintenance Level

Organizational

Tools and Special Tools

Jackstands (2)

Tool Kit, General Mechanic's

Materials/Parts

Cotter Pins (4) (Item 4, WP 0061 00)

Lockwashers (12) (Items 13, 16 & 17,
WP 0061 00)

References

page 0033 00-5

Equipment Conditions

Hubs and Brakedrums Removed (WP 0039 00)

REMOVAL

WARNING

If trailer is not coupled to towing vehicle, ensure that landing gear is lowered and locked. Failure to follow this warning may cause trailer to roll, resulting in injury to personnel or damage to equipment.

1. Remove cotter pin (5), flatwasher (4), clevis pin (2), and disconnect yoke (3) from handbrake lever (1). Discard cotter pin.

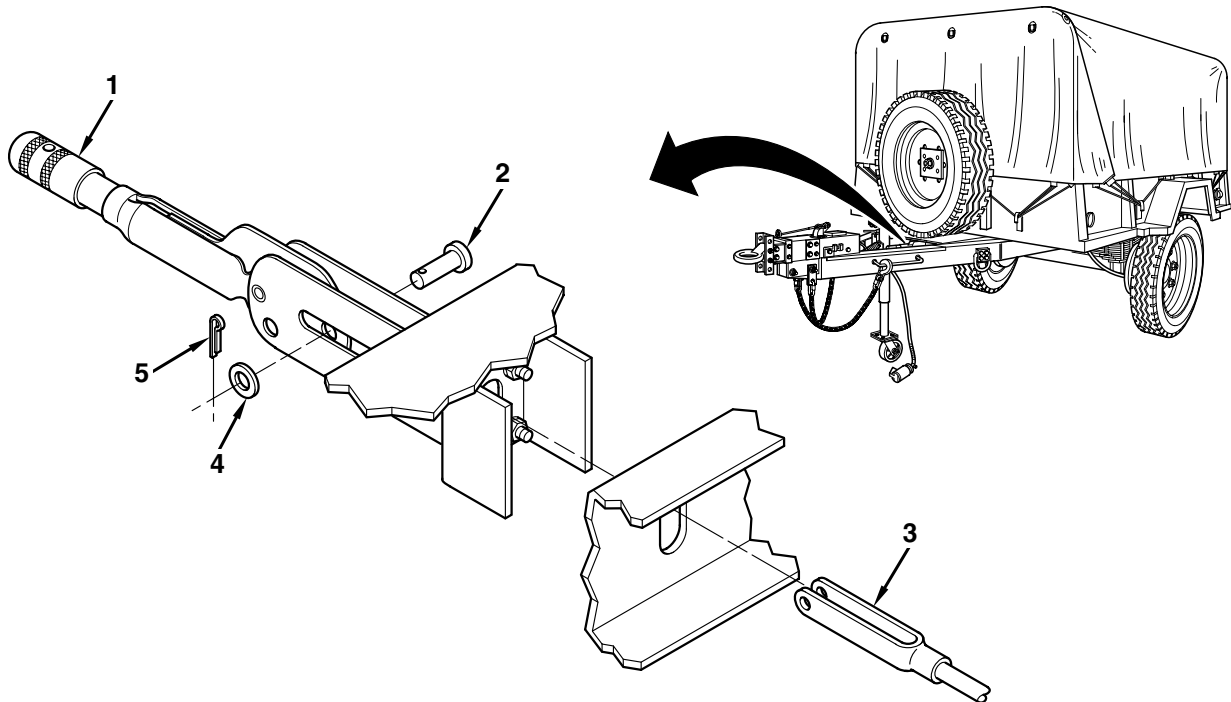

REMOVAL—Continued

2. Loosen nut (11). Remove cotter pin (13), clevis pin (9), yoke (10), nut (11), and rod (12). Discard cotter pin.
3. Remove cotter pin (7) and clevis pin (6). Discard cotter pin.
4. Repeat step 3 for other side.
5. Remove six nuts (14), lockwashers (15), flatwashers (16), screws (18), flatwashers (17), and shaft assembly (8). Discard lockwashers.

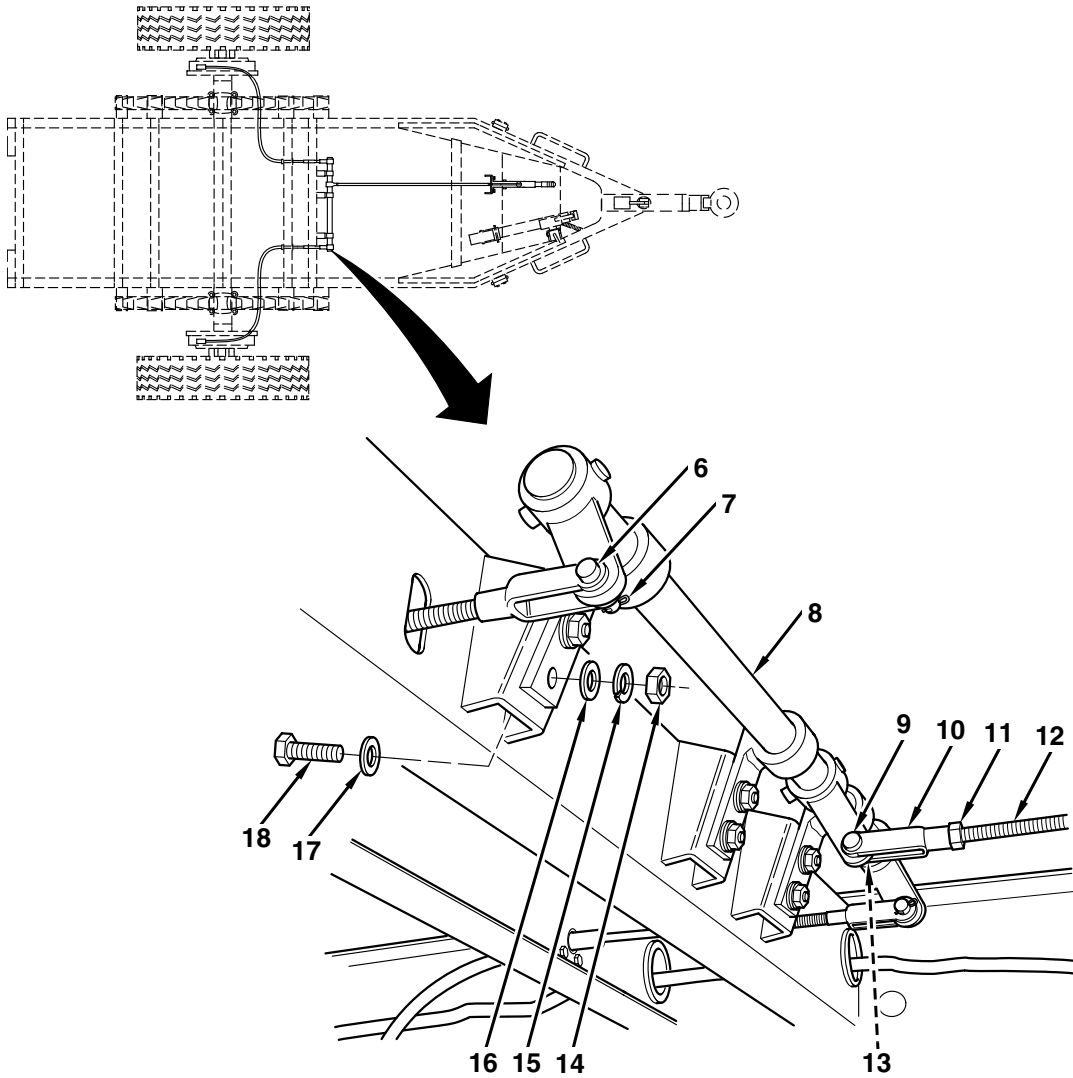

REMOVAL—Continued

6. Remove yoke (20) from handbrake cable assembly (19).
7. Remove nut (29), lockwasher (28), two flatwashers (27), screw (26), and pull out cable assembly (19). Discard lockwasher.
8. Remove two nuts (25), lockwashers (24), flatwashers (23), screws (21), and cable block (22). Discard lockwashers.
9. Repeat steps 6 through 8 for other side.

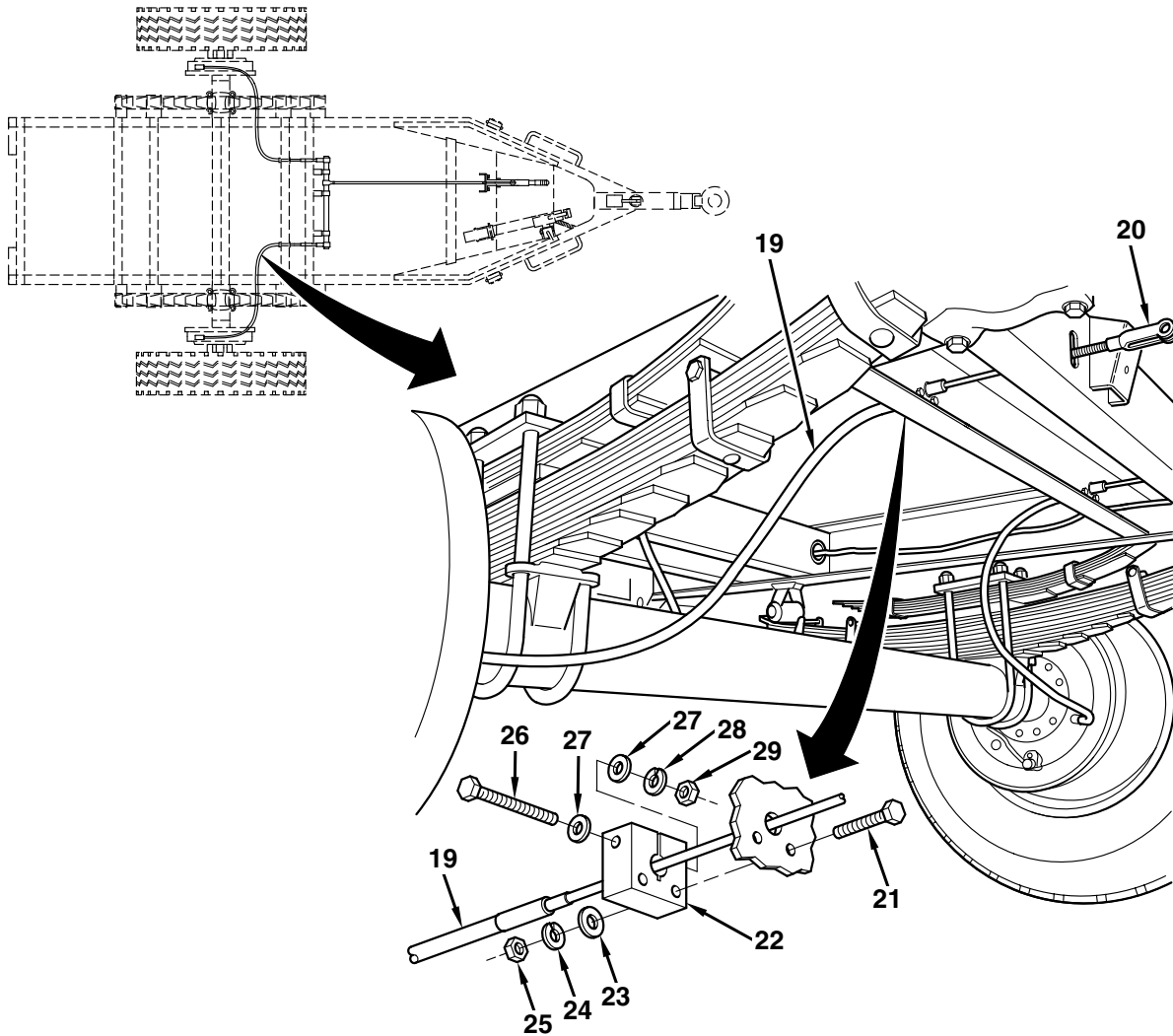

REMOVAL—Continued

10. Disconnect handbrake cable assembly (19) from brake lever (30).
11. Loosen two nuts (32) from guide bracket (33) and backing plate (31).
12. Remove handbrake cable assembly (19).
13. Inspect cable assembly (19) for cracks, breaks, or damage.
14. Replace defective parts.
15. Repeat steps 10 through 14 for other side.

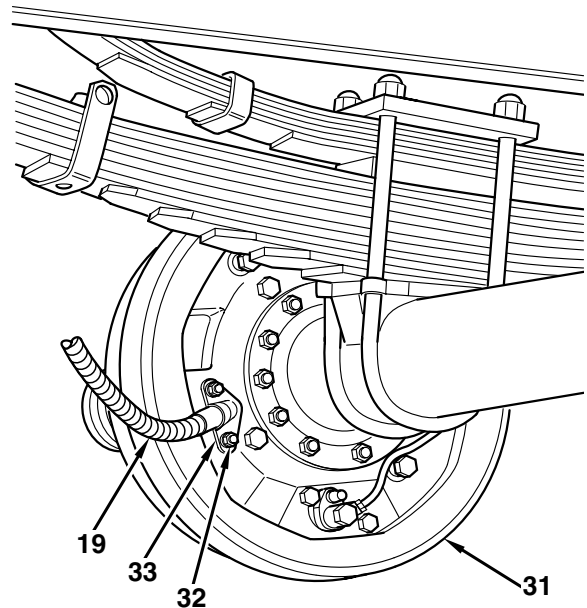
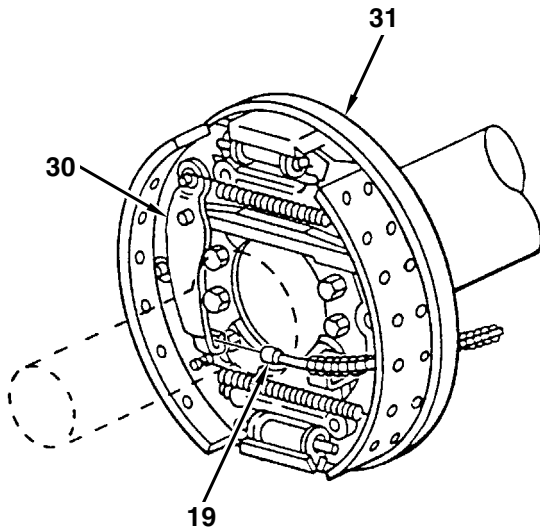

INSTALLATION

WARNING

If trailer is not coupled to towing vehicle, ensure that landing gear is lowered and locked. Failure to follow this warning may cause trailer to roll, resulting in injury to personnel or damage to equipment.

1. Insert handbrake cable assembly (19) through guide bracket (33) and backing plate (31).
2. Tighten two nuts (32).
3. Connect handbrake cable assembly (19) to brake lever (30).
4. Repeat steps 1 through 3 for other side.

INSTALLATION—Continued

5. Slide handbrake cable assembly (19) through cable block (22). Solid sheath on cable assembly should be positioned 0.25 in. (6.4 mm) from back side of cable block.

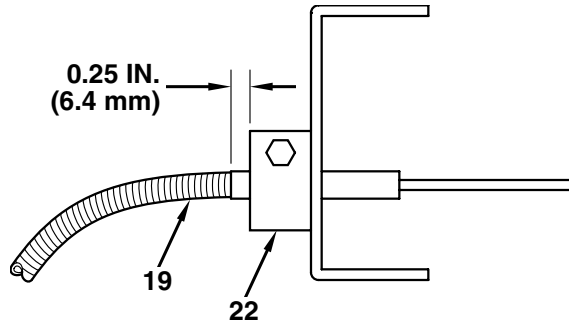

6. Install screw (26), two flatwashers (27), new lockwasher (28), and nut (29).
7. Install cable block (22), two screws (21), flatwashers (23), new lockwashers (24), and nuts (25).
8. Install yoke (20) on end of handbrake cable assembly (21). Install turnbuckle 0.875 in. (22.2 mm) onto cable assembly end.

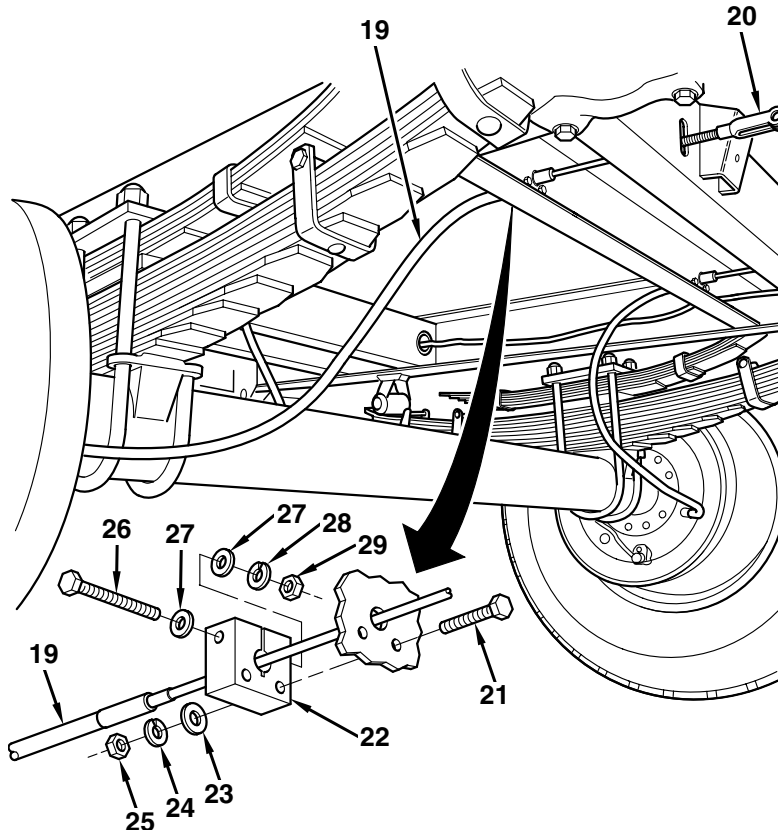

INSTALLATION—Continued

9. Repeat steps 5 through 8 for other side.
10. Install shaft assembly (8), six flatwashers (17), screws (18), flatwashers (16), new lockwashers (15), and nuts (14).
11. Install clevis pin (6) and new cotter pin (7).
12. Repeat step 11 for other side.
13. Install rod (12), nut (11), yoke (10), clevis pin (9), and new cotter pin (13). Yoke should be installed 1 in. (25.4 mm) onto end of rod.

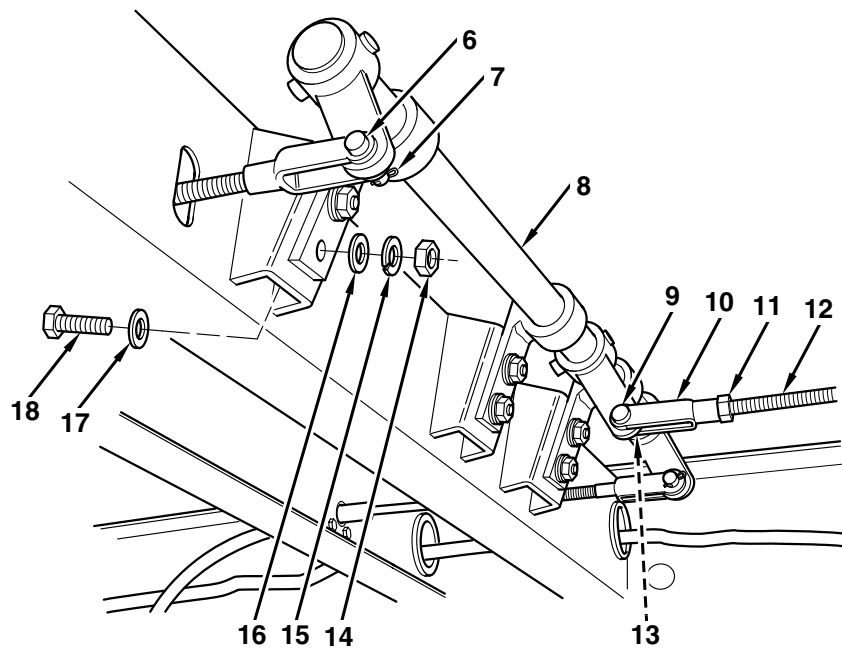

INSTALLATION—Continued

14. Install yoke (3), clevis pin (2), flatwasher (4), and new cotter pin (5) on handbrake lever (1). Yoke should be installed 1 in. (25.4 mm) onto end of rod.

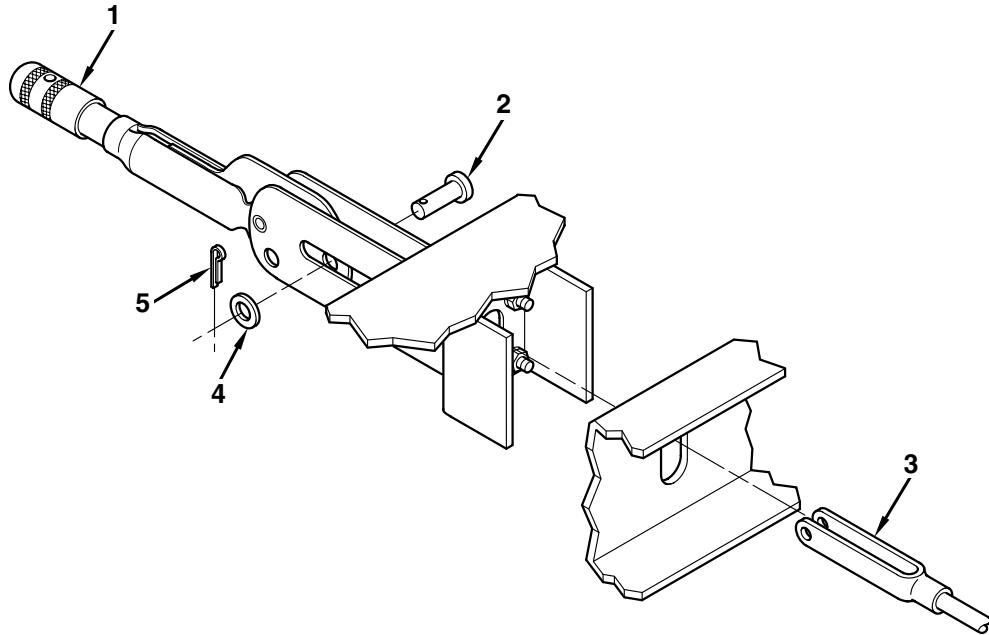

15. Install hubs and brakedrums (WP 0039 00).

ADJUSTMENT

WARNING

If trailer is not coupled to towing vehicle, ensure that landing gear is lowered and locked and wheels are securely chocked. Failure to follow this warning may cause trailer to roll, resulting in injury to personnel or damage to equipment.

NOTE

- Handbrake is properly adjusted when additional force is required to move handbrake lever (1) beyond 2/3 distance of travel toward applied position.
 - Ensure proper brake shoe clearance before adjusting linkage (page 0033 00-5).
1. Raise one side of trailer with rear jack and place a jackstand on corner of rear crossmember. Lower and remove rear jack. Repeat for other side.
 2. Release handbrake by raising handbrake lever (1) up to vertical position.

ADJUSTMENT—Continued

NOTE

If only one wheel engages, go to step 7.

3. Set adjusting knob on handbrake lever (1) by turning clockwise as far as possible. Then turn knob counterclockwise 2 full turns. Handbrake lever is now set.
4. Ensure that yoke (10) and yoke (3) are installed on rod (12) equally. This should be 1 in. (25.4 mm) from threaded end of yoke (10) and yoke (3) to ends of rod.
5. Adjust turnbuckle (10) first, rotating toward front of trailer. Only rotate 1/2 to 1 full turn at a time and retest after every adjustment. Not more than 1 or 2 full turns should be needed. If necessary, adjust clevis (3) toward rear of trailer again in small increments and test after each adjustment.
6. Install clevis pin (9) and new cotter pin (13). Tighten nut (11).
7. Remove cotter pin (7) and clevis pin (6). Discard cotter pin.
8. Rotate turnbuckle (20) as required to eliminate excess slack or tension. Rotate both turnbuckles at the same time. Turnbuckles should not interfere with frame when parking brake assembly is rotated through its full motion.
9. Install both clevis pins (6) and actuate handbrake lever. Turn each wheel and note the drag. Remove both clevis pins (6) and turn turnbuckles (20) as required to set equal drag on each wheel.
10. Repeat step 9 until wheels equally lock.
11. Install clevis pin (6) and new cotter pin (7).

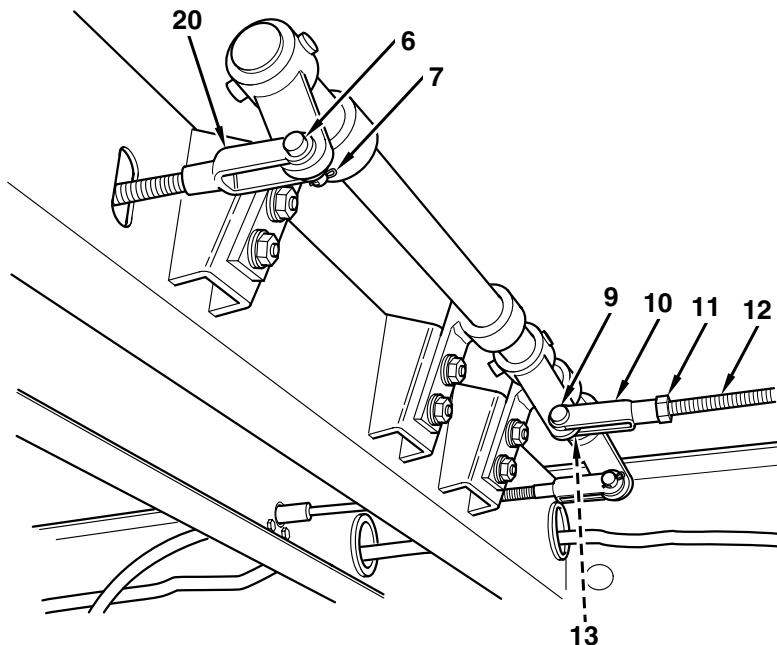

END OF TASK

SERVICE BRAKE ASSEMBLY MAINTENANCE

0033 00

THIS WP COVERS:Disassembly, Cleaning, Inspection, Assembly, Adjustment

INITIAL SETUP:**Maintenance Level**

Organizational

Tools and Special Tools

Jackstands (2)

Tool Kit, General Mechanic's

Materials/Parts

Solvent, Cleaning (Item 10, WP 0060 00)

Lockwashers (36) (Items 8, 9 & 16,

WP 0061 00)

References

WP 0032 00

WP 0038 00

Equipment Conditions

Axle Hydraulic Lines Disconnected From Backing

Plate, if Removing Backing Plate (WP 0037 00)

Hub and Brakedrum Removed (WP 0039 00)

DISASSEMBLY**WARNING**

Do not handle brakeshoes, brakedrums, or other brake components unless area has been properly cleaned. There may be hazardous dust on these components which can be dangerous if you touch it or breathe it. Wear an approved filter mask and gloves. Never use compressed air or a dry brush to clean brake components. Dust may be removed using an industrial-type vacuum cleaner. Clean dust or mud away from brake components with water and a wet, soft cloth. Failure to follow this warning may result in serious illness or death.

DISASSEMBLY—Continued

NOTE

If replacing brakeshoes (8 and 17) only, perform steps 1 through 5.

1. Remove two springs (1) from pins (6, 18, 23, and 29).
2. Disconnect handbrake cable (24) from brake lever (5).
3. Remove two slotted washers (2), flatwashers (3), spring washers (4), brake lever (5), and link (7) from pins (6 and 23).
4. Remove screw (30), lockwasher (31), flatwasher (32), sleeve (33), and brakeshoe (8) from backing plate (11). Discard lockwasher.
5. Remove nut (20), lockwasher (19), flatwasher (21), sleeve (22), bolt (14), and brakeshoe (17) from backing plate (11). Discard lockwasher.
6. Remove 12 nuts (15), lockwashers (16), bolts (26), cable ramp (25), two supports (12), and backing plate (11) from axle (13). Discard lockwashers.
7. Remove brake adjusting screw (28) and slack adjusting wheel (27) from each support (12).
8. Remove four nuts (10) and lockwashers (9) from pins (6, 18, 23, and 29). Remove pins from brakeshoes (8 and 17). Discard lockwashers.

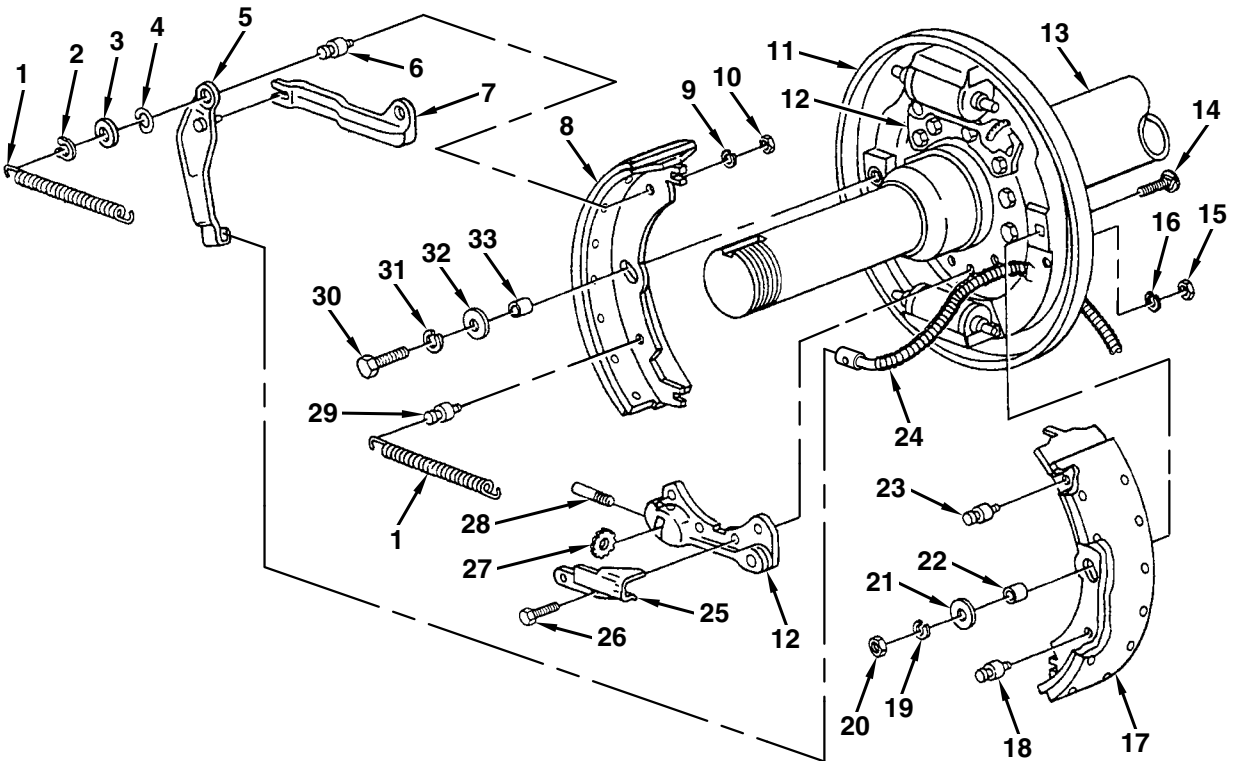

CLEANING**WARNING**

- Do not handle brakeshoes, brakedrums, or other brake components unless area has been properly cleaned. There may be hazardous dust on these components which can be dangerous if you touch it or breathe it. Wear an approved filter mask and gloves. Never use compressed air or a dry brush to clean brake components. Dust may be removed using an industrial-type vacuum cleaner. Clean dust or mud away from brake components with water and a wet, soft cloth. Failure to follow this warning may result in serious illness or death.
- Solvents can burn easily, can give off harmful vapors, and are harmful to skin and clothing. To avoid injury or death, keep away from open fire and use in a well-ventilated area. If solvent gets on skin or clothing, wash immediately with soap and water.

Clean all parts with cleaning solvent. Dry thoroughly.

INSPECTION

1. Inspect all removed components for rust, obvious defects, and excessive wear. Replace any rusted, defective, or worn parts.
2. Inspect brakeshoe linings (34) for cracks and wear. Replace brakeshoe if:
 - a. Brakeshoe is cracked
 - b. Brakeshoe lining is less than 0.125 in. (3.2 mm) in thickness
 - c. Depth of rivet heads (35) is not at least 0.063 in. (1.6 mm) below brakeshoe lining, or
 - d. Grease is present

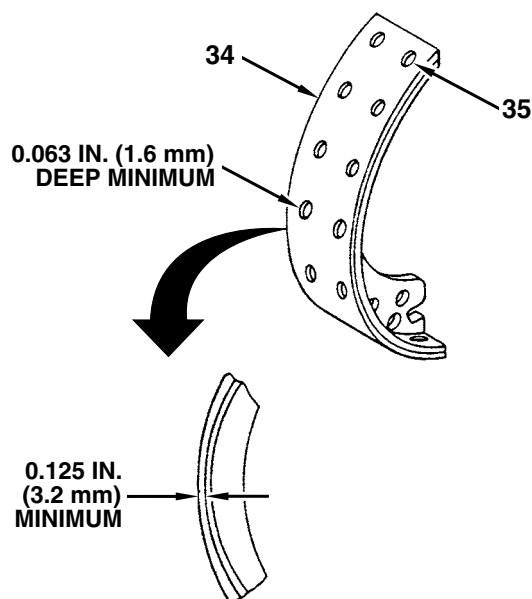

ASSEMBLY

NOTE

If replacing brakeshoes (8 and 17) only, perform steps 4 through 9.

1. Install pins (6, 18, 23, and 29) on brakeshoes (8 and 17) with four new lockwashers (9) and nuts (10).
2. Install slack adjusting wheel (27) and brake adjusting screw (28) on each support (12).
3. Position backing plate (11), two supports (12), and cable ramp (25) on axle (13) and install 12 bolts (26), new lockwashers (16), and nuts (15).
4. Position brakeshoe (17) on backing plate (11) and install bolt (14), sleeve (22), flatwasher (21), new lockwasher (19), and nut (20).
5. Position brakeshoe (8) on backing plate (11) and install sleeve (33), flatwasher (32), new lockwasher (31), and screw (30).
6. Install link (7) on pin (23). Install brake lever (5) on pin (6). Pin on brake lever must engage slot in link.
7. Install two spring washers (4), flatwashers (3), and slotted washers (2) on pins (6 and 23).
8. Install two springs (1) on pins (6, 18, 23, and 29).
9. Connect handbrake cable (24) to brake lever (5).

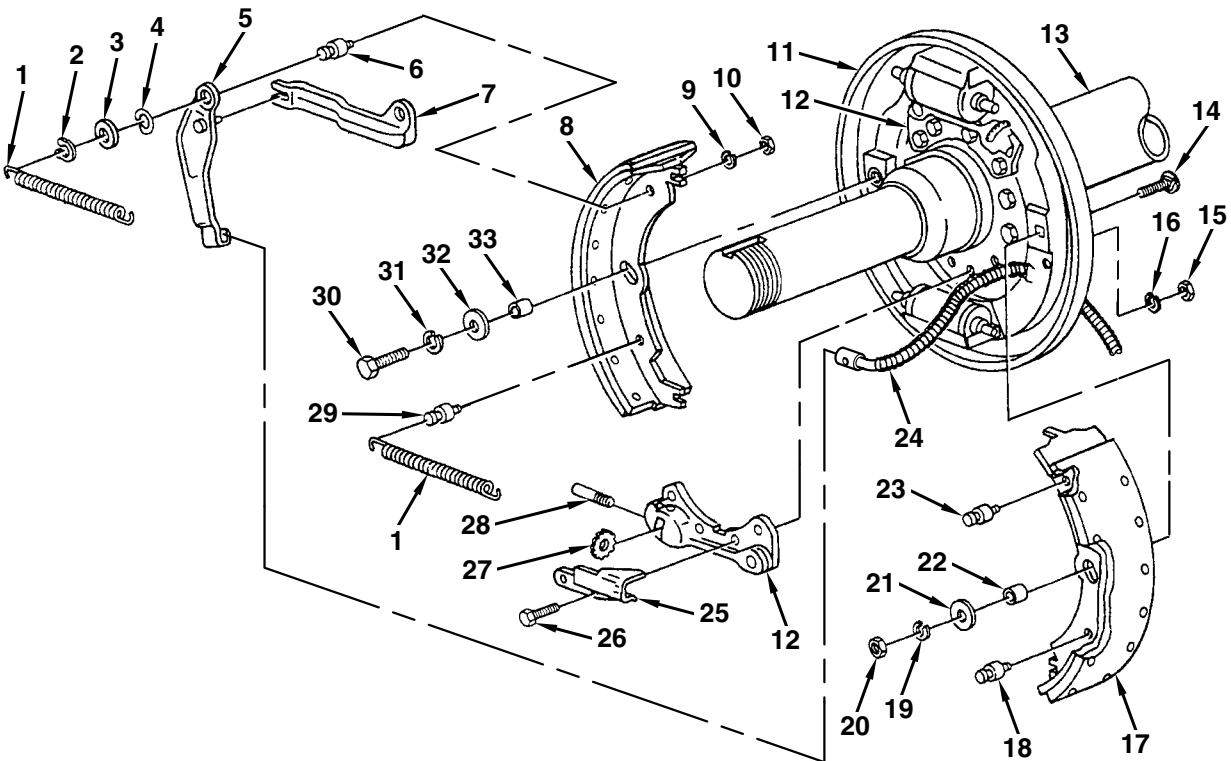

ASSEMBLY—Continued

10. If disconnected, connect axle hydraulic lines to backing plate (WP 0037 00).
11. Install hub and brakedrum (WP 0039 00).

ADJUSTMENT

NOTE

- To ensure an accurate adjustment, this procedure must be performed when brakeshoes are cool.
- Perform this adjustment at each wheel to adjust brakes.

1. Raise one side of trailer with rear jack and place a jackstand on corner of rear crossmember. Lower and remove rear jack. Repeat for other side.
2. On passenger (right) side of trailer, turn upper brakeshoe adjusting bolt (36) and lower brakeshoe adjusting bolt (37) clockwise until brakes are completely released. Check to see that wheel turns freely.
3. On driver (left) side of trailer, turn upper brakeshoe adjusting bolt (36) and lower brakeshoe adjusting bolt (37) counterclockwise until brakes are completely released. Check to see that wheel turns freely.

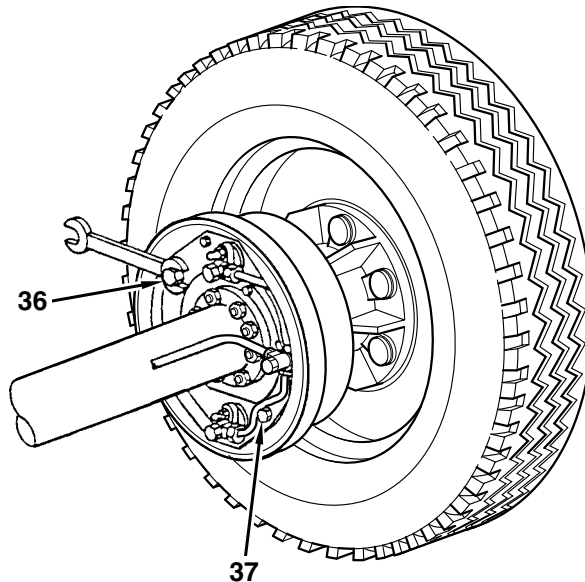

NOTE

Overtightened bearing is evident if a drag occurs when brakes are completely backed off.

ADJUSTMENT—Continued

4. If a drag is present, check to see if drum (hub) has been overtightened. Re-assemble bearings and drum so that wheel turns freely (WP 0039 00).
5. On passenger (right) side of trailer, turn upper brakeshoe adjusting bolt (36) counterclockwise until a slight drag is felt, then back off 4 full turns to allow wheel to turn freely with no drag. Wheel should make several rotations by itself before coming to a stop. Repeat for lower brakeshoe adjusting bolt (37).
6. On driver (left) side of trailer, turn upper brakeshoe adjusting bolt (36) clockwise until a slight drag is felt, then back off 4 full turns to allow wheel to turn freely with no drag. Wheel should make several rotations by itself before coming to a stop. Repeat for lower brakeshoe adjusting bolt (37).

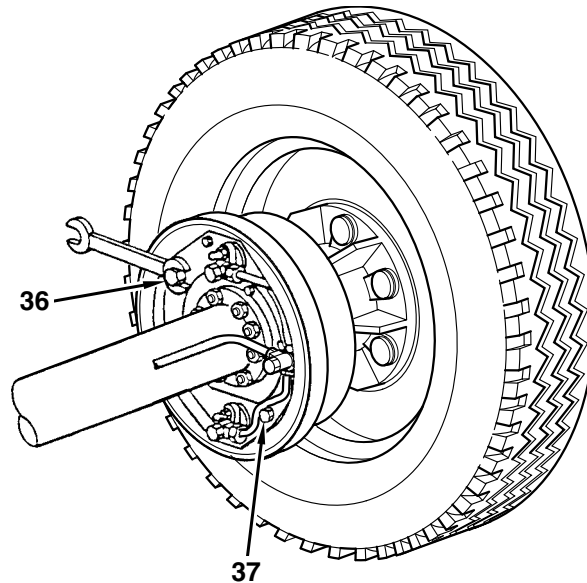

NOTE

After an initial break-in period, brakes may need to be re-adjusted. If required, repeat steps 1 through 6.

FOLLOW-ON TASKS

1. Bleed brakes if axle hydraulic lines were disconnected from backing plate (WP 0038 00).
2. Adjust handbrake linkage and cables (WP 0032 00).

END OF TASK

BRAKE ACTUATOR REPLACEMENT

0034 00

THIS WP COVERS:

Removal, Cleaning, Installation

INITIAL SETUP:

Maintenance Level

Organizational

Tools and Special Tools

Drain Pan
Tool Kit, General Mechanic's

Materials/Parts

Rags, Wiping (Item 9, WP 0060 00)
Brake Actuator (Item 27, WP 0061 00)
Breakaway Lever Assy (Item 28, WP 0061 00)
Breakaway Lock—Left (Item 30, WP 0061 00)
Breakaway Lock—Right (Item 29, WP 0061 00)
Cotter Pins (2) (Item 5, WP 0061 00)
Gasket (Item 31, WP 0061 00)
Lockwashers (6) (Items 15 & 17, WP 0061 00)

References

WP 0038 00

Equipment Conditions

Drawbar Coupler Removed (WP 0041 00)
Safety Chains Removed (WP 0042 00)

REMOVAL

NOTE

Use a suitable container to catch any draining brake fluid. Ensure that all spills are cleaned up.

1. Disconnect hose (5) from tube assembly (6).
2. Remove nut (4), lockwasher (3), screw (7), clamp (2), and hose (5).

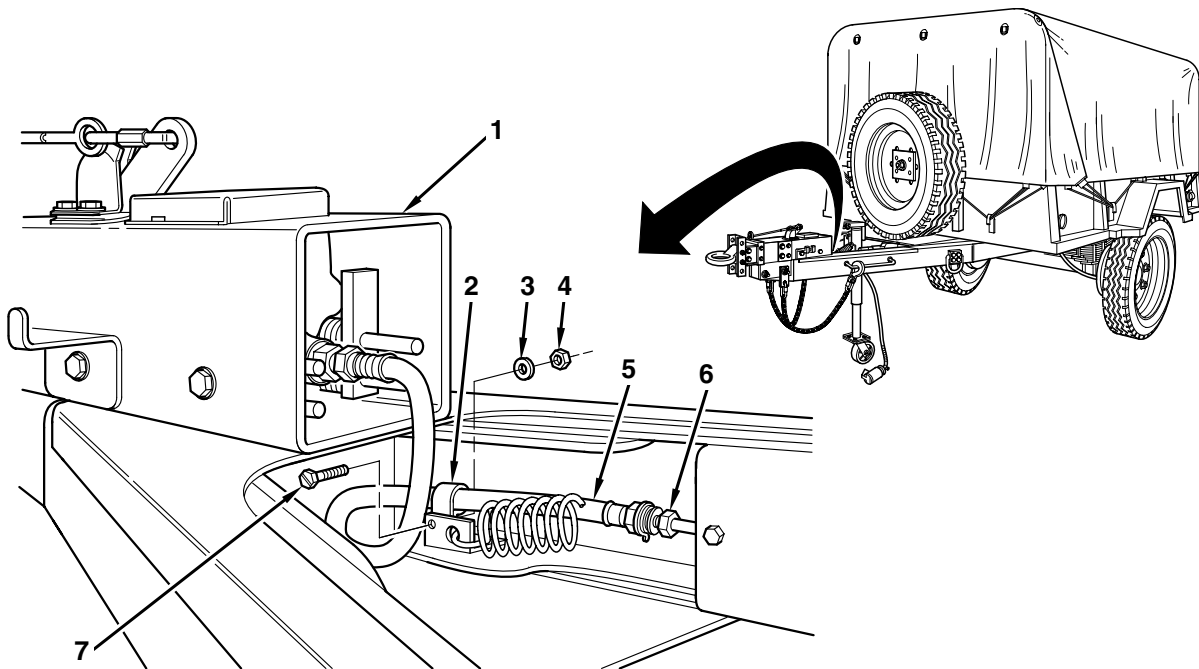

BRAKE ACTUATOR REPLACEMENT—Continued

0034 00

REMOVAL—Continued

3. Remove four screws (13), lockwashers (12), flatwashers (11), two breakaway locks (14), gasket (10), and breakaway lever (15) with breakaway chain (16) attached. Discard lockwashers, breakaway locks, gasket, and breakaway lever.
4. Remove bolt (19), lockwasher (18), and cable holder (17).
5. Remove cotter pin (20), nut (21), flatwasher (22), screw (8), flatwasher (9), and brake actuator (1). Discard cotter pin and brake actuator.

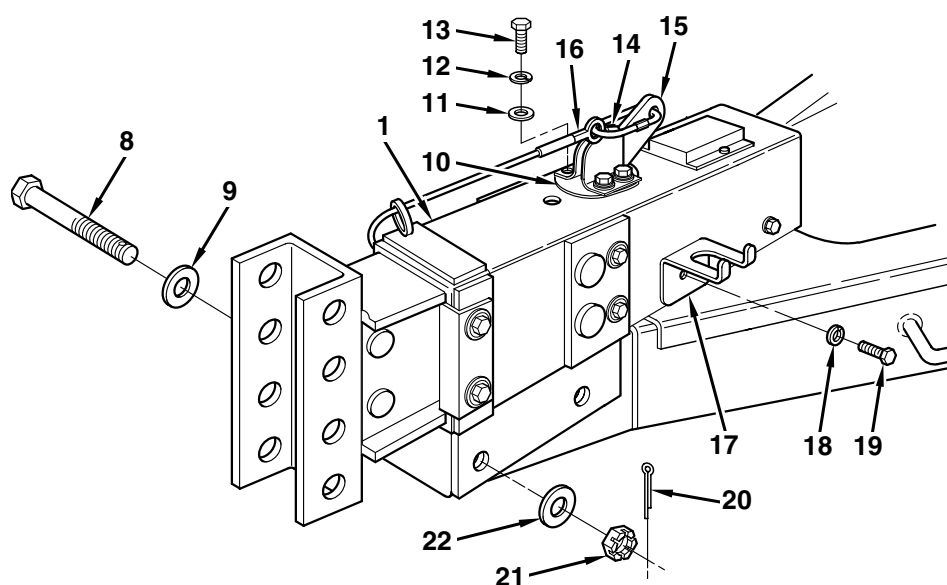
**CLEANING**

Clean area under brake actuator.

INSTALLATION**NOTE**

A suitable container should be used to catch any draining brake fluid. Ensure that all spills are cleaned up.

1. Install new brake actuator (1), flatwasher (9), screw (8), flatwasher (22), nut (21), and new cotter pin (20).
2. Install cable holder (17), new lockwasher (18), and bolt (19).
3. Install new breakaway lever (15) with breakaway cable (16) attached, new gasket (10), two new breakaway locks (14), four flatwashers (11), new lockwashers (12), and screws (13).

INSTALLATION—Continued

4. Connect hose (5) to brake actuator (1).
5. Install hose (5) to tube assembly (6).
6. Install clamp (2), screw (7), new lockwasher (3), and nut (4).

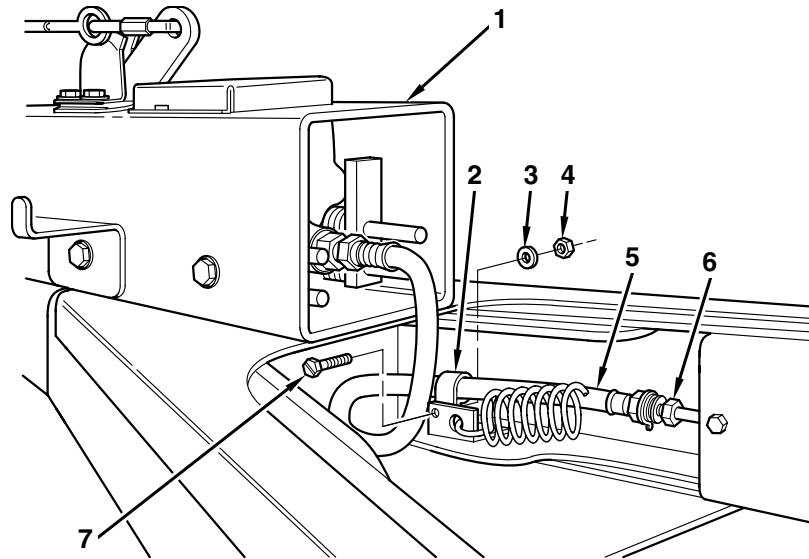

FOLLOW-ON TASKS

1. Install safety chains (WP 0042 00).
2. Install drawbar coupler (WP 0041 00).
3. Bleed brakes (WP 0038 00).

END OF TASK

EMERGENCY BRAKING BREAKAWAY LEVER RESET

0035 00

THIS WP COVERS:

Reset

INITIAL SETUP:

Maintenance Level

Organizational

Tools and Special Tools

Tool Kit, General Mechanic's

Materials/Parts

- Breakaway Lever Assy (Item 28, WP 0061 00)
- Breakaway Lock—Left (Item 30, WP 0061 00)
- Breakaway Lock—Right (Item 29, WP 0061 00)
- Gasket (Item 31, WP 0061 00)
- Lockwashers (4) (Item 17, WP 0061 00)

References

WP 0034 00

RESET

1. Remove four screws (1), lockwashers (2), flatwashers (3), right and left breakaway locks (4 and 6), breakaway lever assembly (7), and gasket (5). Discard lockwashers, gasket, breakaway locks, and breakaway lever assembly.

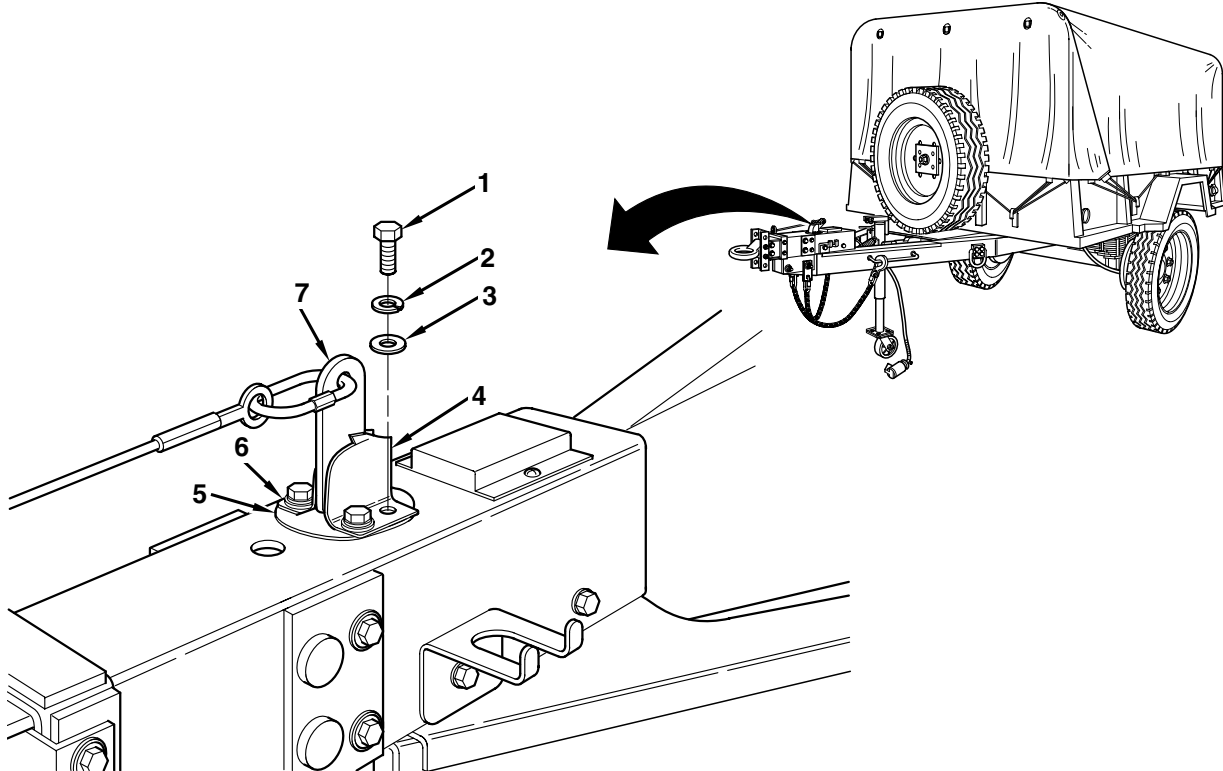

RESET—Continued

2. Install new gasket (5), new breakaway lever assembly (7), new right and left breakaway locks (4 and 6), four flatwashers (3), new lockwashers (2), and screws (1).

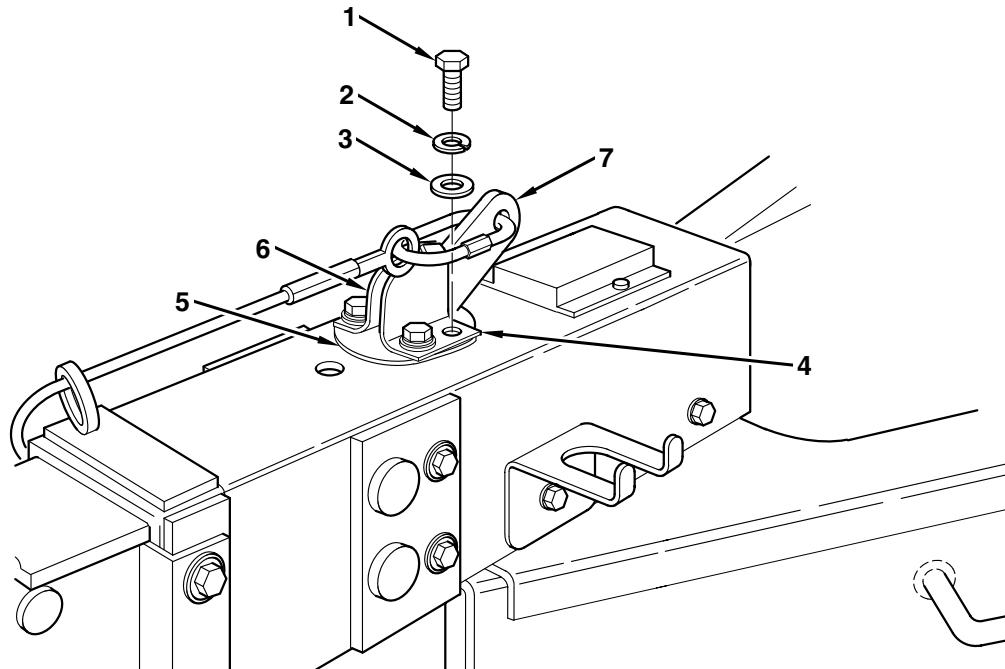

END OF TASK

WHEEL CYLINDER REPLACEMENT

0036 00

THIS WP COVERS:

Removal, Installation

INITIAL SETUP:

Maintenance Level

Organizational

Tools and Special Tools

Drain Pan
Tool Kit, General Mechanic's

Materials/Parts

Rags, Wiping (Item 9, WP 0060 00)

References

WP 0038 00

Equipment Conditions

Service Brakes Disassembled (WP 0033 00)

REMOVAL

NOTE

- Wheel cylinders (5) in right and left service brake assemblies are removed the same way. This procedure covers one service brake assembly.
- A suitable container should be used to catch any draining brake fluid. Ensure that all spills are cleaned up.

1. Remove bolt (1), flatwasher (2), and spacer (4) from connector (3) and wheel cylinder (5).
2. Remove two screws (8), wheel cylinder (5), and shield (6) from backing plate (7).
3. Repeat steps 1 and 2 for other wheel cylinder.

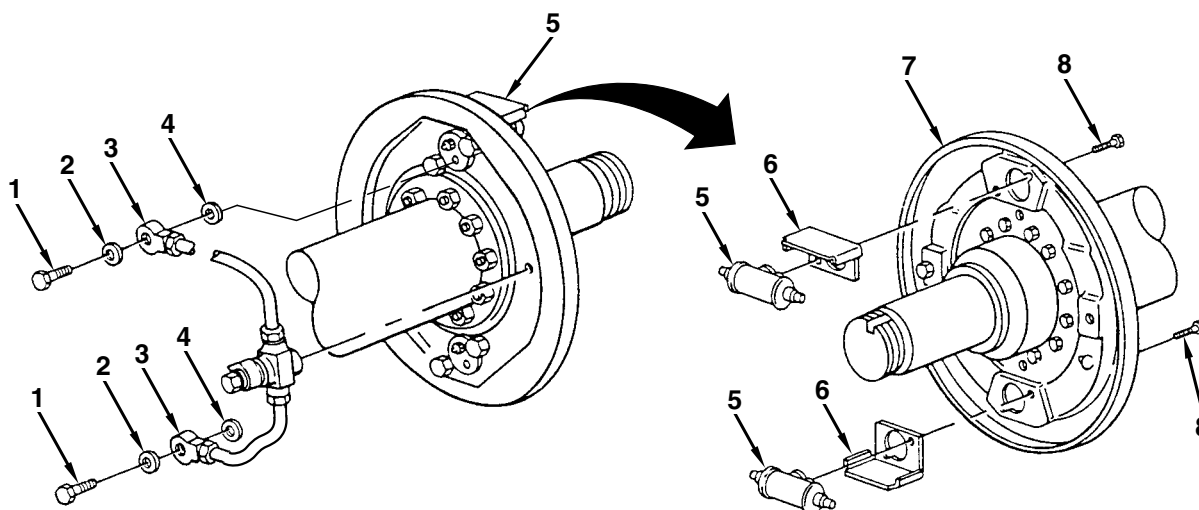

WHEEL CYLINDER REPLACEMENT—Continued

0036 00

INSTALLATION

NOTE

Wheel cylinders (5) in right and left service brake assemblies are installed the same way. This procedure covers one service brake assembly.

1. Position shield (6) and wheel cylinder (5) on backing plate (7) and install two screws (8).
2. Install spacer (4), flatwasher (2), and bolt (1) on connector (3) and wheel cylinder (5).
3. Repeat steps 1 and 2 for other wheel cylinder.

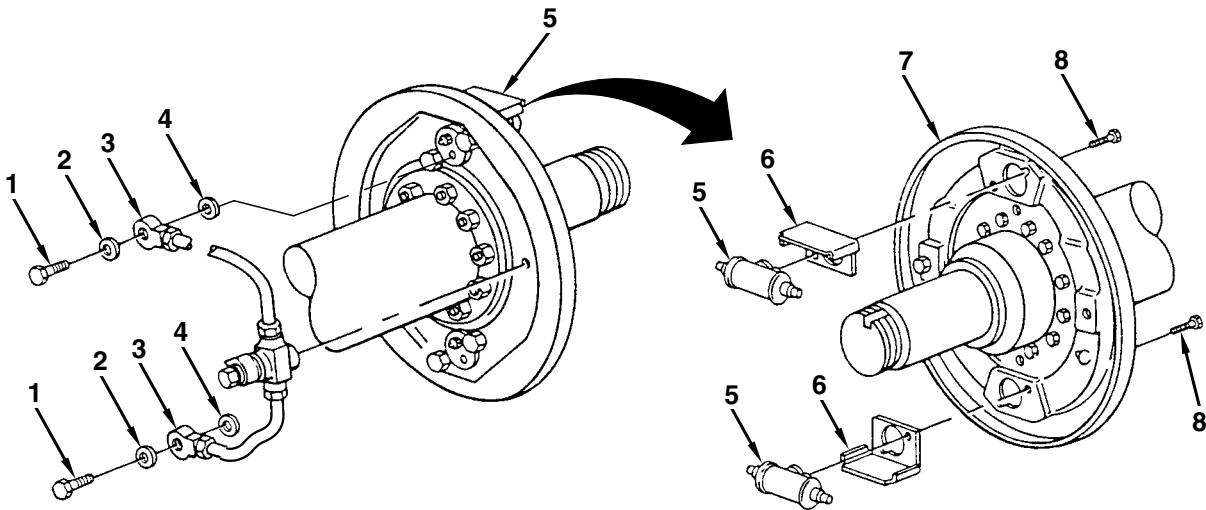

FOLLOW-ON TASKS

1. Assemble service brakes (WP 0033 00).
2. Bleed brakes (WP 0038 00).

END OF TASK

HYDRAULIC BRAKE LINES AND FITTINGS REPLACEMENT

0037 00

THIS WP COVERS:

Removal, Installation

INITIAL SETUP:

Maintenance Level

Organizational

Tools and Special Tools

Drain Pan

Tool Kit, General Mechanic's

Materials/Parts

Rags, Wiping (Item 9, WP 0060 00)

Lockwashers (7) (Items 15 & 16, WP 0061 00)

References

WP 0038 00

REMOVAL

WARNING

If trailer is not coupled to towing vehicle, ensure that landing gear is lowered and locked and wheels are securely chocked. Failure to follow this warning may cause trailer to roll, resulting in injury to personnel or damage to equipment.

NOTE

A suitable container should be used to catch any draining brake fluid. Ensure that all spills are cleaned up.

Rear Hose

1. Disconnect tube (2) from hose (1).
2. Remove clip (3), hose (1), two nuts (5), lockwashers (6), screws (7), and bracket (4). Discard lockwashers.
3. Remove hose (1) from union tee (8).

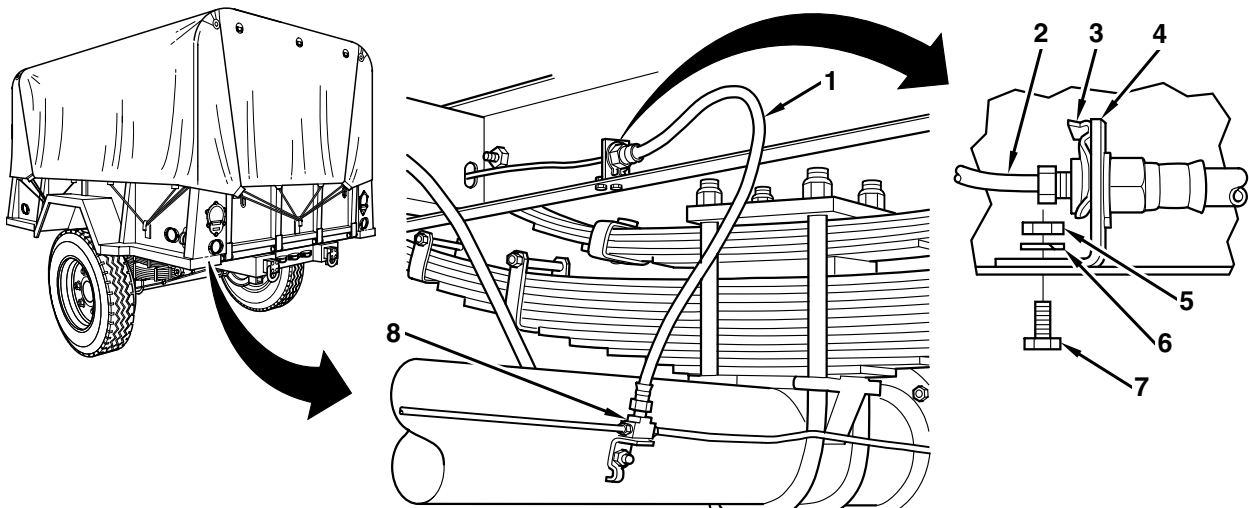

REMOVAL—Continued

Axle Tube Assemblies and Union Tee

1. Remove tube assembly (11).
2. Remove nut (14), lockwasher (15), clamp (8), and tube assembly (9). Discard lockwasher.
3. Remove nut (12), lockwasher (13), and union tee (10). Discard lockwasher.

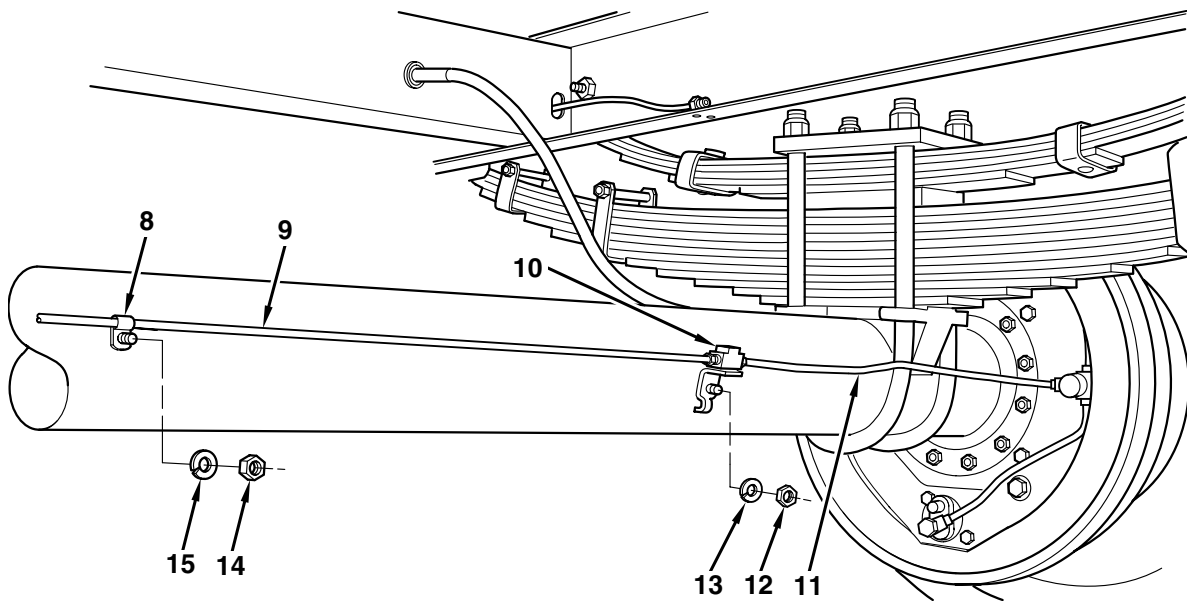

Backing Plate Tube Assemblies

1. Remove tube assemblies (16 and 17).
2. Repeat step 1 for other side.

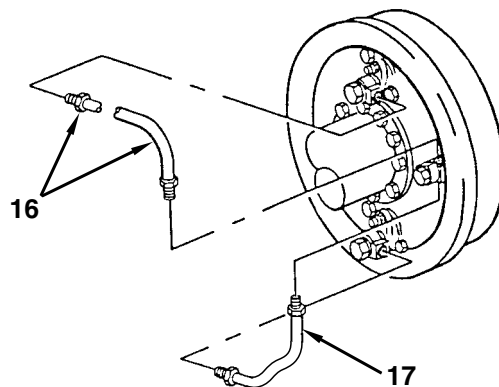

REMOVAL—Continued

Middle Tubes and Front Hose

1. Remove nut (21), lockwasher (20), screw (18), and clamp (19). Disconnect front hose (22) from middle tube (33) and remove front hose from brake actuator.
2. Remove nut (23), lockwasher (24), screw (26), and clamp (25). Discard lockwasher.
3. Remove two nuts (27), lockwashers (28), screws (30), clamps (29), middle tubes (31 and 33), and union (32). Discard lockwashers.

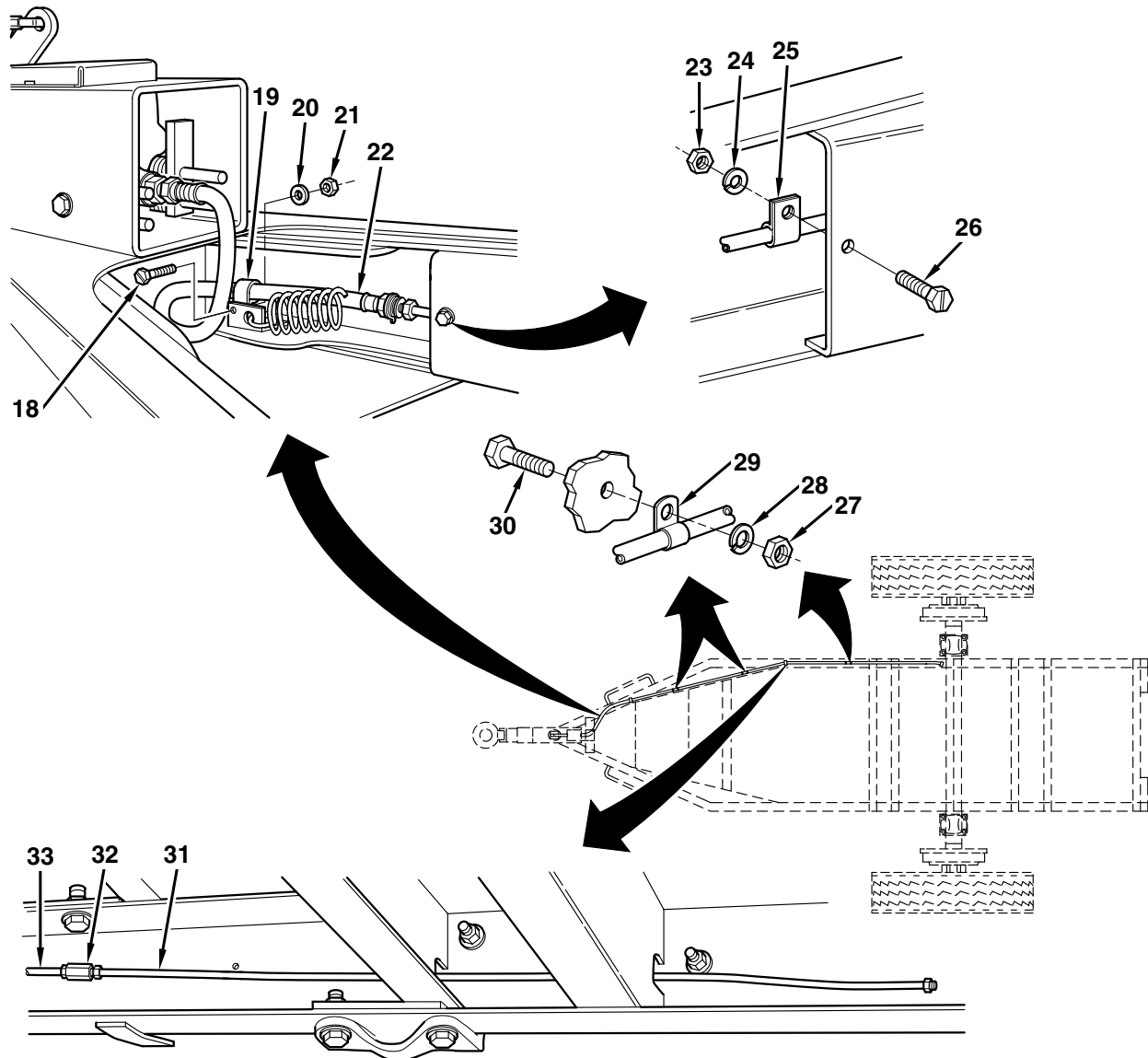

INSTALLATION

Front Hose and Middle Tubes

1. Install middle tubes (31 and 33), union (32), two clamps (29), screws (30), new lockwashers (28), and nuts (27).
2. Install clamp (25), screw (26), new lockwasher (24), and nut (23).
3. Connect front hose (22) to brake actuator. Then connect other end to middle tube (33). Install clamp (19), screw (18), new lockwasher (20), and nut (21).

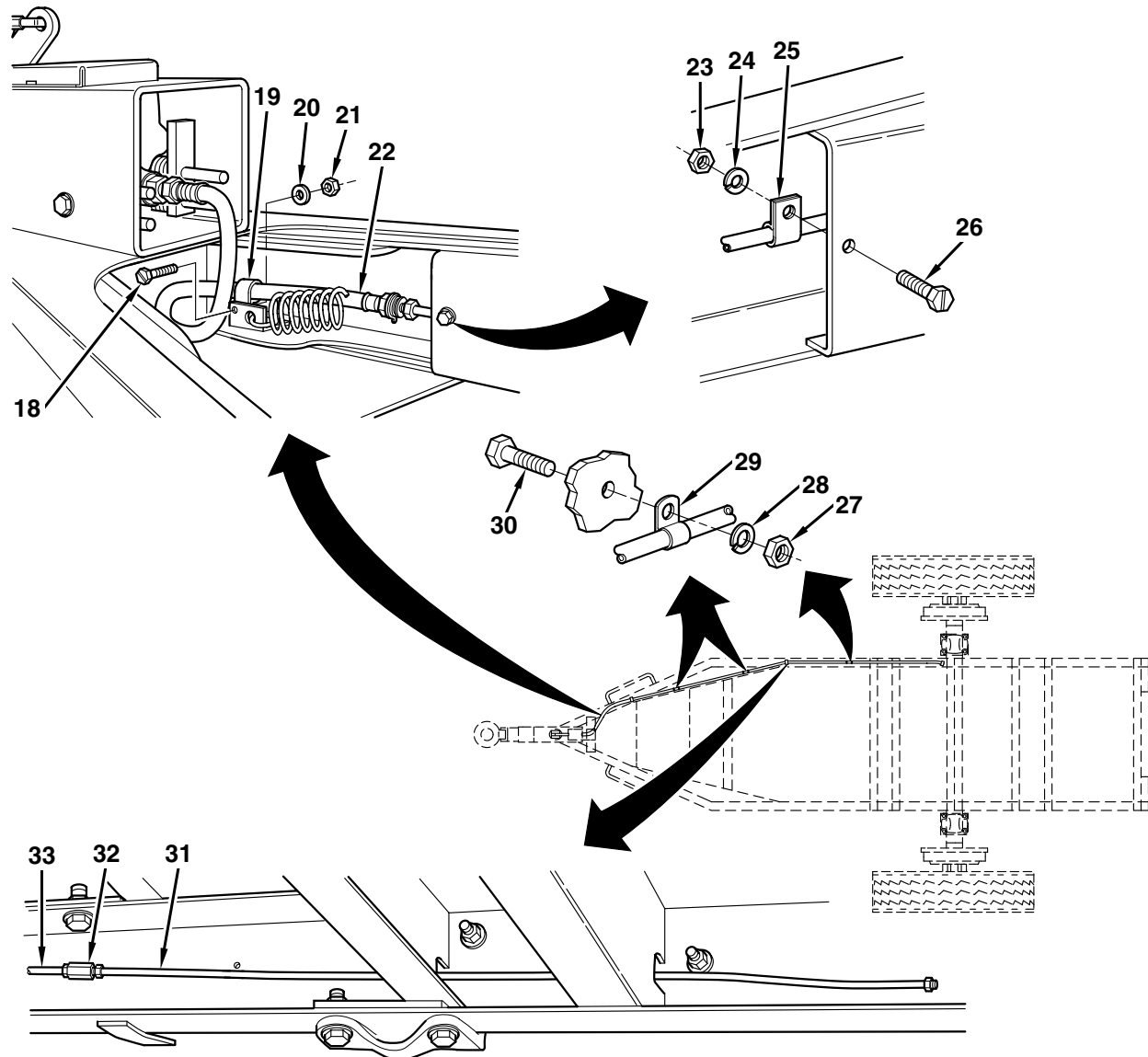

INSTALLATION—Continued

Backing Plate Tube Assemblies

1. Install tube assemblies (17 and 16).
2. Repeat step 1 for other side.

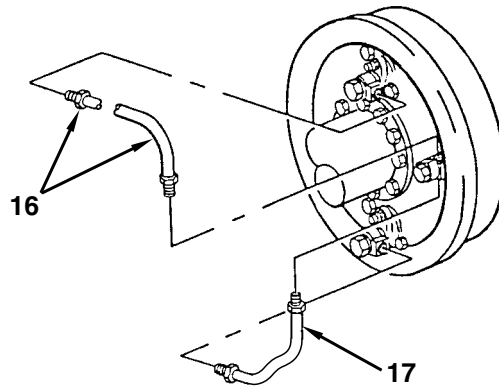

Axle Tube Assemblies and Union Tee

1. Install union tee (10), new lockwasher (13), and nut (12).
2. Install tube assembly (9), clamp (8), new lockwasher (15), and nut (14).
3. Install tube assembly (11).

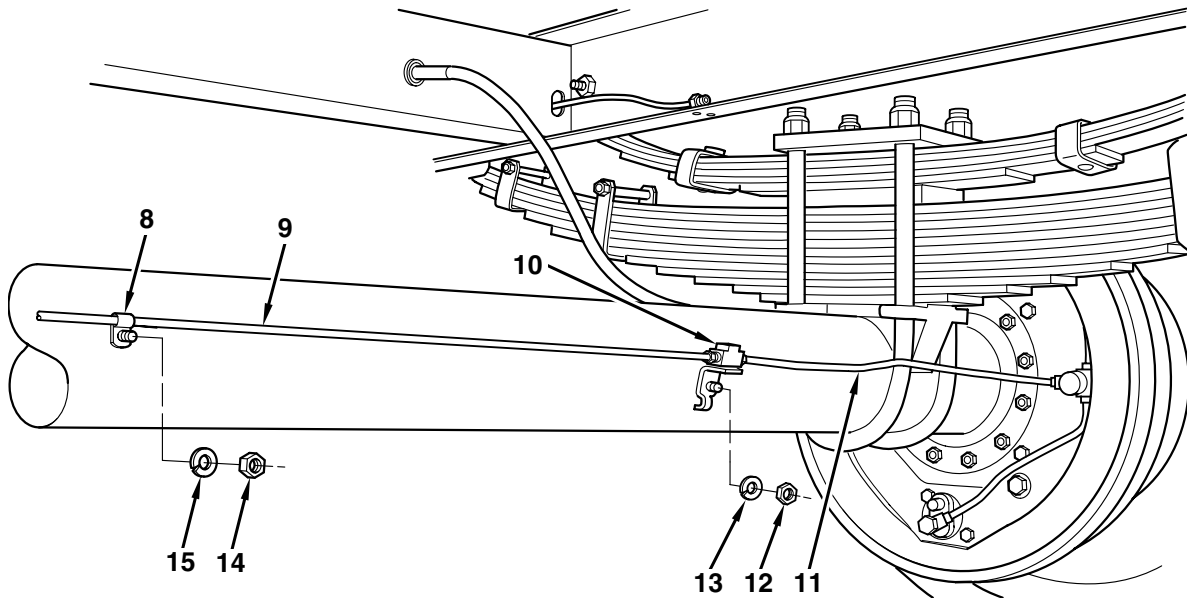

INSTALLATION—Continued

Rear Hose

1. Install bracket (4), two screws (7), new lockwashers (6), and nuts (5).
2. Install hose (1) to union tee (8).
3. Connect hose (1) to tube (2) and install clip (3).

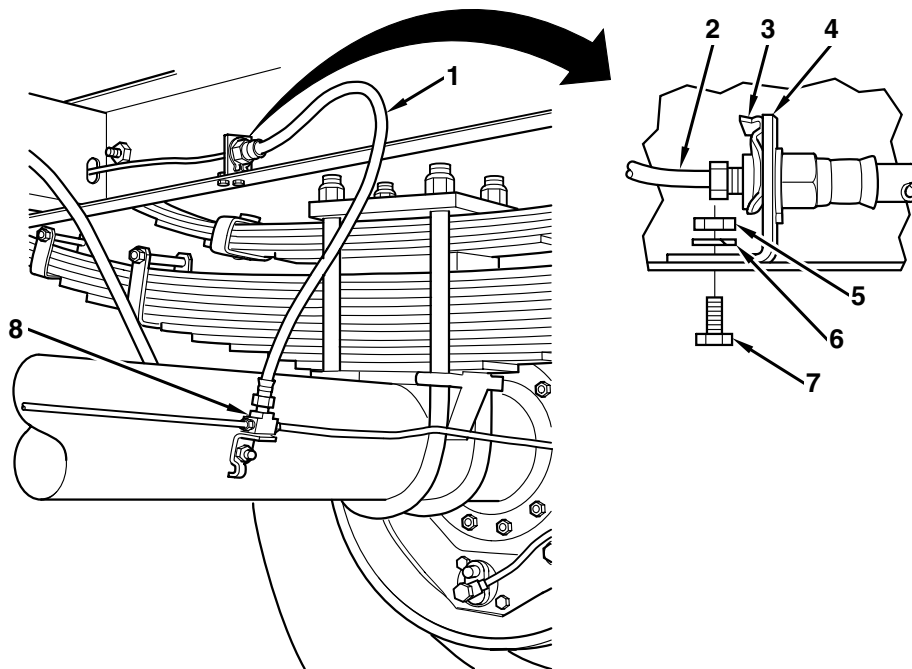

FOLLOW-ON TASK

Bleed brakes (WP 0038 00).

END OF TASK

BLEEDING BRAKE SYSTEM0038 00

THIS WP COVERS:Pressure Bleeding

INITIAL SETUP:**Maintenance Level**

Organizational

Tools and Special Tools

Drain Pan

Tool Kit, General Mechanic's

Utility Pail

Materials/Parts

Fluid, Brake (Item 4, WP 0060 00)

Rags, Wiping (Item 9, WP 0060 00)

Tubing, Plastic (Item 11, WP 0060 00)

Cotter Pins (2) (Item 5, WP 0061 00)

PersonnelTwo

PRESSURE BLEEDING**WARNING**

- When performing maintenance on brake system, ensure that landing gear is lowered and locked and that wheels are securely chocked. Failure to follow this warning may cause trailer to roll, resulting in serious injury or death to personnel.
- Drawbar is heavy—up to 400 lb (181 kg) loaded tongue weight. Do not attempt to lift drawbar. Use landing gear to raise and lower drawbar. Failure to follow this warning may result in serious injury or death.
- Eye injury may result if brake fluid comes in contact with eyes. Always wear eye protection when working with brake fluid. Failure to follow this warning may result in injury to personnel.
- Use only fresh brake fluid from a sealed container; do not reuse fluid. After filling and bleeding, be sure to refill master cylinder to 3/4 full. Failure to maintain an adequate fluid level may cause brake failure, resulting in injury to personnel or damage to equipment.

NOTE

- Ensure that fluid level in master cylinder is 3/4 full at all times during this task to avoid allowing air to enter hydraulic system.
- A suitable container should be used to catch any draining brake fluid. Ensure that all spills are cleaned up.

1. Disconnect trailer from towing vehicle and raise trailer tongue with landing gear until horizontal.

PRESSURE BLEEDING—Continued

2. Install one end of bleeder hose (1) to driver's side (left) upper wheel cylinder bleeder fitting (2) and other end of hose in clean container (3).

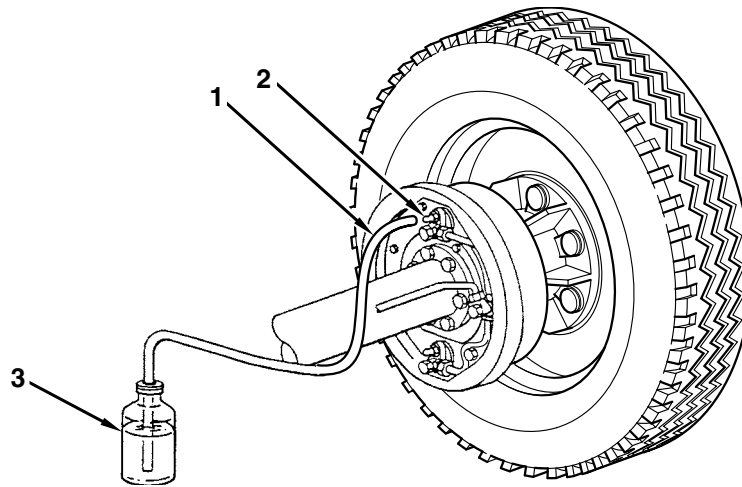

3. Remove two screws (6) and cover (5).

CAUTION

Dirt, water, or grease will contaminate brake fluid, causing brake system damage. Clean exterior of master cylinder (8) and filler cap (7) before removing cap.

4. Remove filler cap (7) from master cylinder (8).
5. Install brake bleeder interface fitting (4) on master cylinder (8).

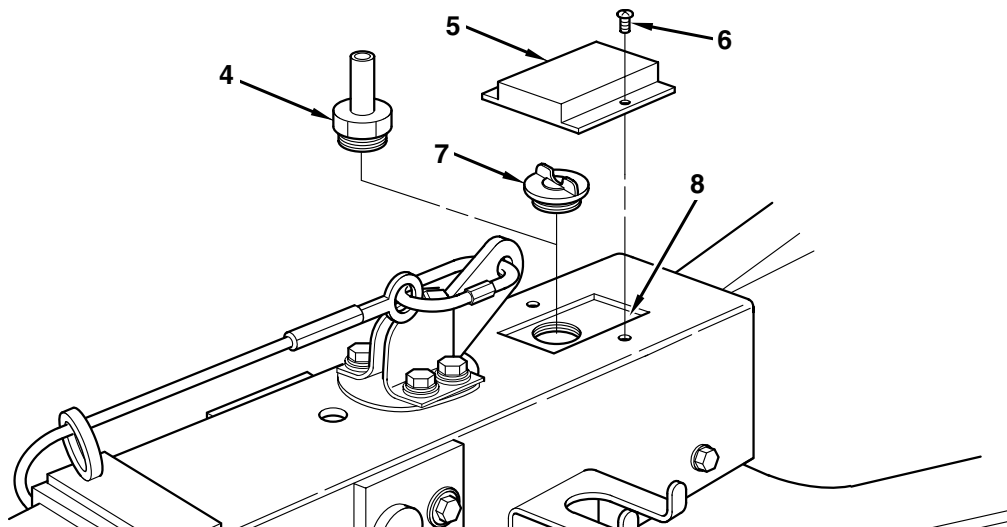

PRESSURE BLEEDING—Continued

6. Ensure that valve (10) on brake bleeder quick disconnect (9) is closed, then connect quick disconnect to brake bleeder interface fitting (4).
7. If pressure gauge (12) on canister (13) indicates positive pressure, bleed pressure through air passage valve (14).
8. Remove top (11) of canister (13). Using a long, blunt object, make sure bladder in canister is depressed. Bleed pressure through air passage valve (14) while slowly depressing blunt object. Fill canister with sufficient amount of brake fluid. Replace top.

WARNING

Excessive air pressure could cause injury to personnel or damage to equipment. Use care when using air pressure equipment. Failure to follow this warning may result in injury to personnel or damage to equipment.

9. Insert 20 psi (138 kPa) of air into canister (13) through air passage valve (14) until gauge (12) indicates 20 psi (138 kPa). Carefully open driver's side (left) upper bleeder valve.
10. Open brake bleeder valve (10) 2 turns.

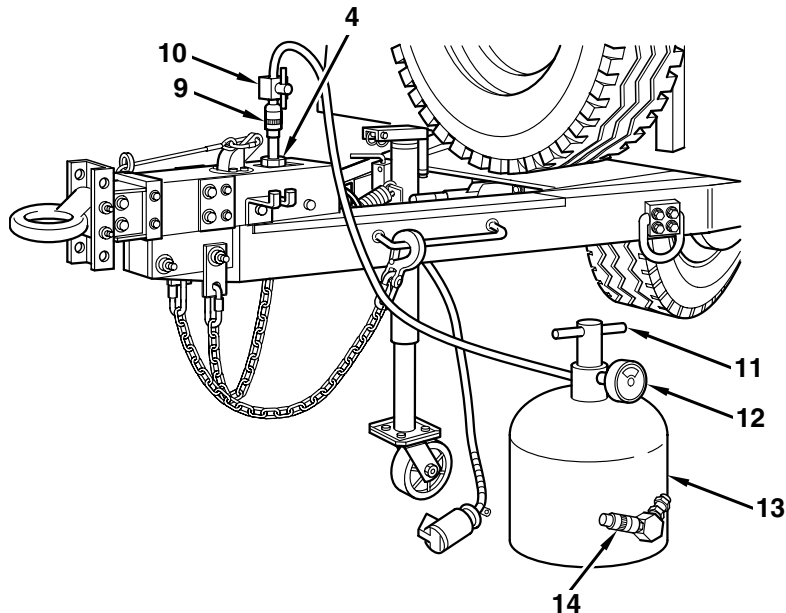

NOTE

Bleeding both wheel cylinders is performed in the same manner. Ensure both wheel cylinders are bled by starting at the top and then bleeding the bottom.

PRESSURE BLEEDING—Continued

11. Starting with driver's side (left) upper bleeder valve (2), drain brake fluid into container (3). Continue draining until brake fluid is free of air bubbles. Close wheel cylinder bleeder fitting.
12. Repeat steps 2 through 11 for driver's side (left) bottom wheel cylinder bleeder fitting, passenger's (right) upper wheel cylinder bleeder fitting, and passenger's (right) lower wheel cylinder bleeder fitting.

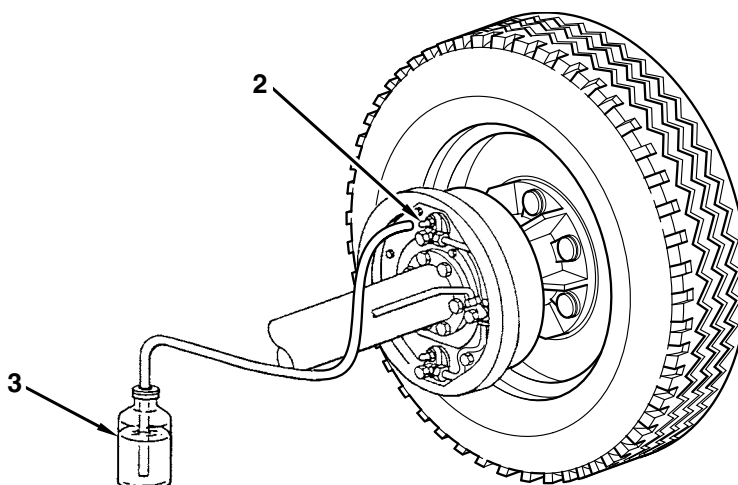

13. Close brake bleeder valve (10).
14. Remove quick disconnect (9) from brake bleeder interface fitting (4). Remove brake bleeder interface fitting.
15. Bleed air from brake bleeder canister (13) at air passage valve (14).

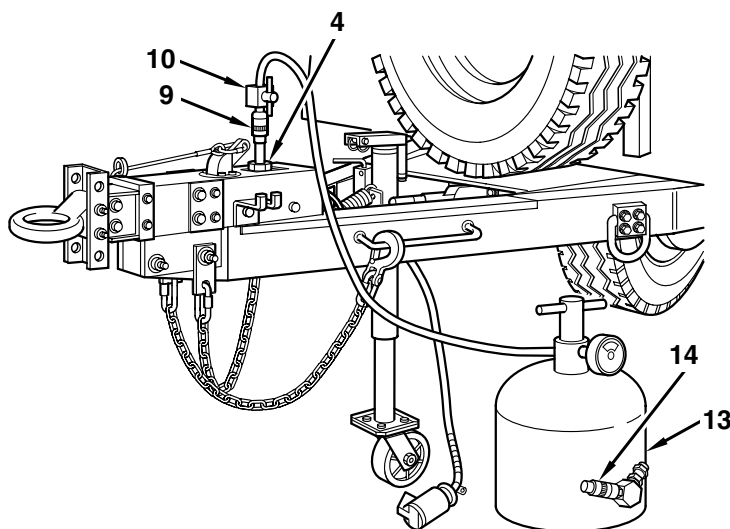

PRESSURE BLEEDING—Continued

16. Master cylinder (8) should be approximately 3/4 full. Add brake fluid as necessary.
17. Remove two cotter pins (16) and master pins (17). Discard cotter pins.
18. Move inner casing (15) slowly back and forth while watching inside of master cylinder (8) being careful not to pull inner casing out of actuator. Continue movement back and forth several times until no air bubbles are visible in master cylinder.
19. Install two master pins (17) and new cotter pins (16).

CAUTION

**Do not use any tool to tighten filler cap (7)—finger-tighten only.
Failure to follow this caution could result in damage to equipment.**

20. Install filler cap (7) on master cylinder (8).
21. Install cover (5) and two screws (6).

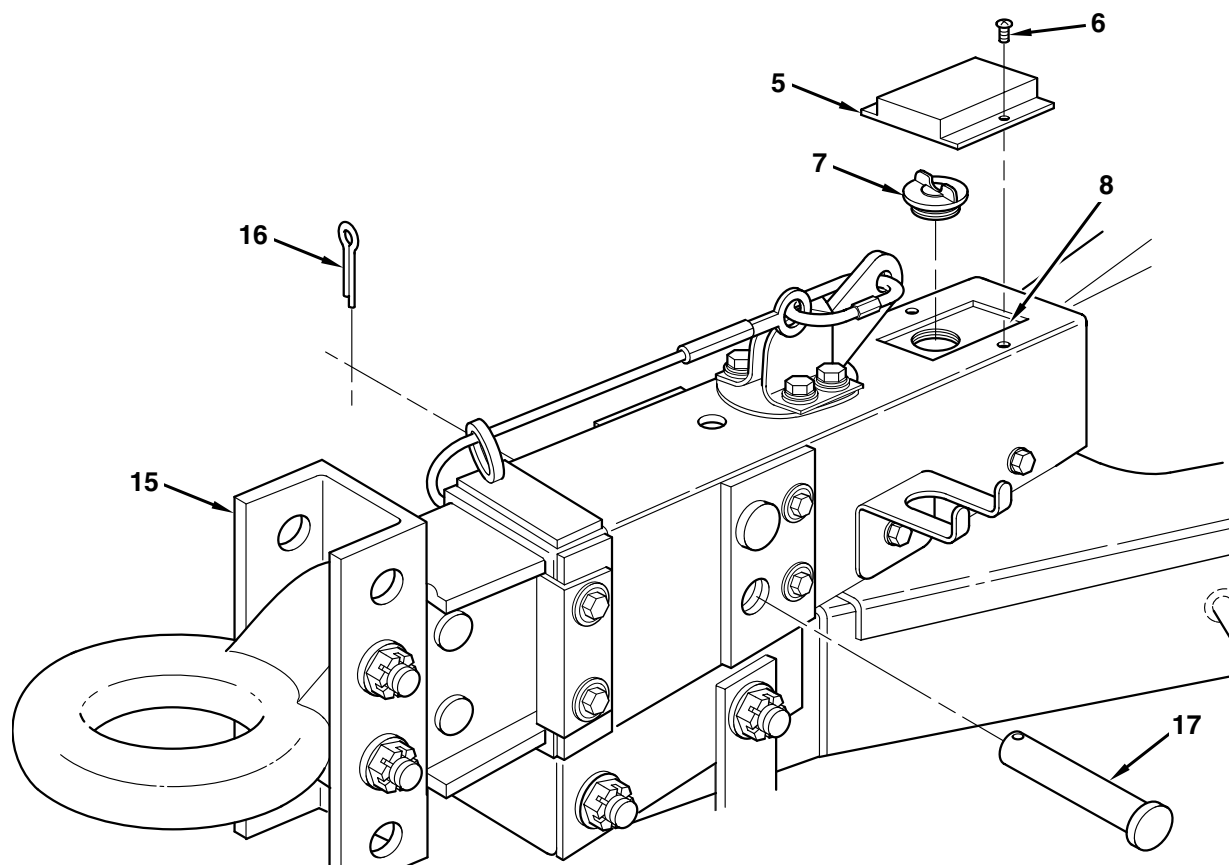
**END OF TASK**

**BRAKEDRUM, WHEEL HUB, AND WHEEL
BEARING MAINTENANCE**

0039 00

THIS WP COVERS:

Removal, Disassembly, Assembly, Installation, Wheel Bearing Adjustment

INITIAL SETUP:

Maintenance Level

Organizational

Tools and Special Tools

Jackstand

Socket, Socket Wrench, 3/4-in. Drive (Wheel
Bearings)

Tool Kit, General Mechanics'

Materials/Parts

Grease (Item 5, WP 0060 00)

Solvent, Cleaning (Item 10, WP 0060 00)

Gaskets (2) (Item 32, WP 0061 00)

Lockwashers (6) (Item 16, WP 0061 00)

Seals, Oil (2) (Item 36, WP 0061 00)

References

TM 9-214

WP 0033 00

Equipment Conditions

Wheel Removed (WP 0020 00)

REMOVAL

NOTE

Right and left brakedrums/wheel hubs/wheel bearings are removed and disassembled the same way. This procedure covers one side.

**BRAKEDRUM, WHEEL HUB, AND WHEEL
BEARING MAINTENANCE—Continued**

0039 00

REMOVAL—Continued

1. Position a suitable jackstand under axle (15). Lower and remove rear jack.
2. Remove three screws (1), lockwashers (2), hubcap (3), and gasket (4) from hub (10). Discard lockwashers and gasket.
3. Remove outer adjusting nut (5), keyed washer (6), and inner adjusting nut (7) from hub (10) and axle (15).
4. Pull hub (10) out slightly on axle (15) to loosen outer wheel bearing cone (8). Remove outer wheel bearing cone from hub and axle.

WARNING

Do not handle brakeshoes, brakedrums, or other brake components unless area has been properly cleaned. There may be hazardous dust on these components which can be dangerous if you touch it or breathe it. Wear an approved filter mask and gloves. Never use compressed air or a dry brush to clean brake components. Dust may be removed using an industrial-type vacuum cleaner. Clean dust or mud away from brake components with water and a wet, soft cloth. Failure to follow this warning may result in serious illness or death.

5. Remove hub (10) and brakedrum (12) from axle (15).
6. Tap inner wheel bearing cone (20), oil seal (19), and spacer sleeve (16) out of hub (10) or axle (15). Discard oil seal.

WARNING

Solvents can burn easily, can give off harmful vapors, and are harmful to skin and clothing. To avoid injury or death, keep away from open fire and use in a well-ventilated area. If solvent gets on skin or clothing, wash immediately with soap and water.

NOTE

If outer and inner wheel bearing cones (8 and 20) need replacing, bearing cups (9) must also be replaced (see DISASSEMBLY on following pages).

7. Clean and inspect outer and inner wheel bearing cones (8 and 20) in accordance with TM 9-214. Discard if damaged.

BRAKEDRUM, WHEEL HUB, AND WHEEL BEARING MAINTENANCE—Continued

0039 00

REMOVAL—Continued

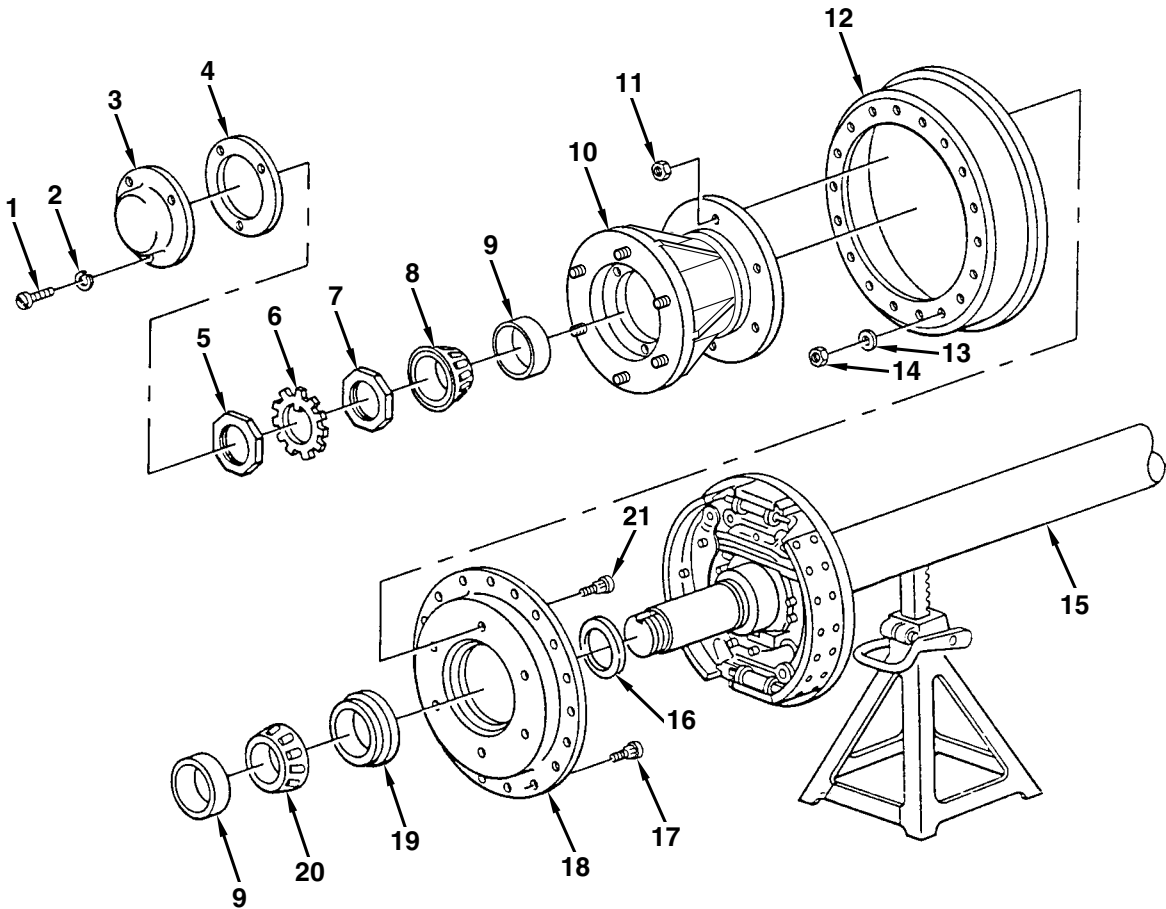

DISASSEMBLY

WARNING

Do not handle brakeshoes, brakedrums, or other brake components unless area has been properly cleaned. There may be hazardous dust on these components which can be dangerous if you touch it or breathe it. Wear an approved filter mask and gloves. Never use compressed air or a dry brush to clean brake components. Dust may be removed using an industrial-type vacuum cleaner. Clean dust or mud away from brake components with water and a wet, soft cloth. Failure to follow this warning may result in serious illness or death.

BRAKEDRUM, WHEEL HUB, AND WHEEL BEARING MAINTENANCE—Continued

0039 00

DISASSEMBLY—Continued

1. Remove six nuts (11) and bolts (21) and remove adapter plate (18) and brakedrum (12) from hub (10).
2. Remove 18 nuts (14), flatwashers (13), bolts (17), and adapter plate (18) from brakedrum (12).

NOTE

Perform step 3 only if bearing cups (9) are being replaced. Bearing cups should always be replaced when outer and inner wheel bearing cones (8 and 20) are replaced.

3. Tap two bearing cups (9) out of hub (10).
4. If damaged, remove six wheel bolts (22) from hub (10).

ASSEMBLY

NOTE

Right and left brakedrums/wheel hubs/wheel bearings are assembled, installed, and adjusted the same way. This procedure covers one side.

1. If removed, install six wheel bolts (22) in hub (10).
2. If removed, tap two bearing cups (9) into hub (10).
3. Position adapter plate (18) on brakedrum (12), and install 18 bolts (17), flatwashers (13), and nuts (14).
4. Position adapter plate (18) and brakedrum (12) on hub (10) and install six bolts (21) and nuts (11).

NOTE

- **Refer to TM 9-214 for instructions for packing outer and inner wheel bearing cones (8 and 20).**
- **When installing spacer sleeve (16), ensure that flange faces inside of trailer.**

5. Pack inner wheel bearing cone (20) with grease. Install inner wheel bearing cone, new oil seal (19), and spacer sleeve (16) on hub (10).

INSTALLATION

1. Install hub (10) and brakedrum (12) on axle (15).
2. Pack outer wheel bearing cone (8) with grease. Install outer wheel bearing cone and inner adjusting nut (7) on hub (10) and axle (15).

WHEEL BEARING ADJUSTMENT

1. Tighten inner adjusting nut (7) while turning hub (10) and brakedrum (12) until drag is felt.

BRAKEDRUM, WHEEL HUB, AND WHEEL BEARING MAINTENANCE—Continued

0039 00

WHEEL BEARING ADJUSTMENT—Continued

2. Rotate hub (10) and brakedrum (12) one full turn. Loosen inner adjusting nut (7) while rocking hub back and forth until looseness is felt.
3. Tighten inner adjusting nut (7) slowly while rocking hub (10) until looseness is no longer felt.
4. Install keyed washer (6) and outer adjusting nut (5) on axle (15). Bend tabs of keyed washer over flat of outer adjusting nut.
5. Install new gasket (4) and hubcap (3) on hub (10) with three new lockwashers (2) and screws (1).
6. Install rear jack and raise trailer. Remove jackstand from axle (15).

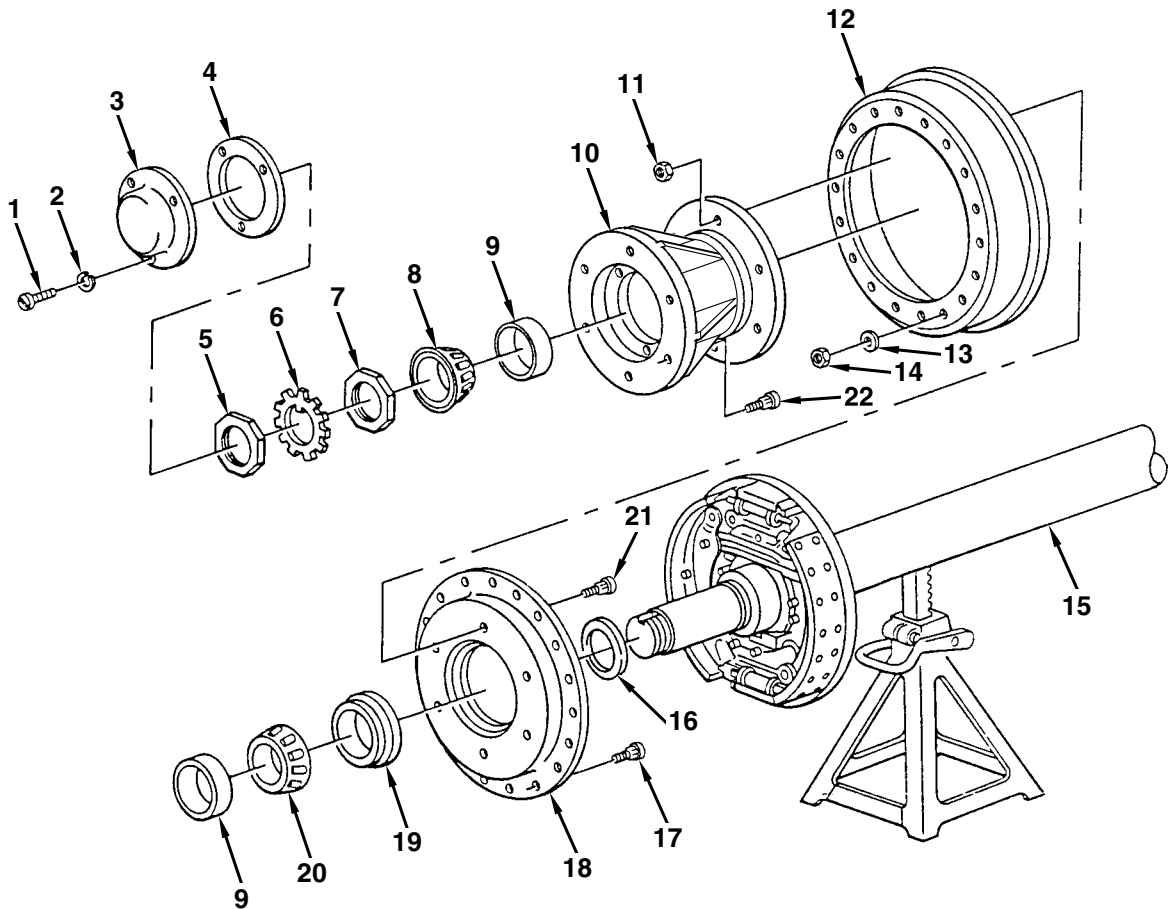

**BRAKEDRUM, WHEEL HUB, AND WHEEL
BEARING MAINTENANCE—Continued**

0039 00

FOLLOW-ON TASKS

1. Install wheel (WP 0020 00).
2. Adjust brakes (WP 0033 00).

END OF TASK

TIRE MAINTENANCE

0040 00

Refer to TM 9-2610-200-24 for instructions on tire maintenance.

DRAWBAR COUPLER REPLACEMENT

0041 00

THIS WP COVERS:

Removal, Installation

INITIAL SETUP:

Maintenance Level

Organizational

Tools and Special Tools

Tool Kit, General Mechanic's

Materials/Parts

Cotter Pins (2) (Item 5, WP 0061 00)

REMOVAL

WARNING

Ensure that landing gear is lowered and locked and wheels are securely chocked. Failure to follow this warning may cause trailer to roll, resulting in injury to personnel or damage to equipment.

Remove two cotter pins (3), nuts (4), screws (1), eight (number may vary) flatwashers (2), and drawbar coupler (5). Discard cotter pins.

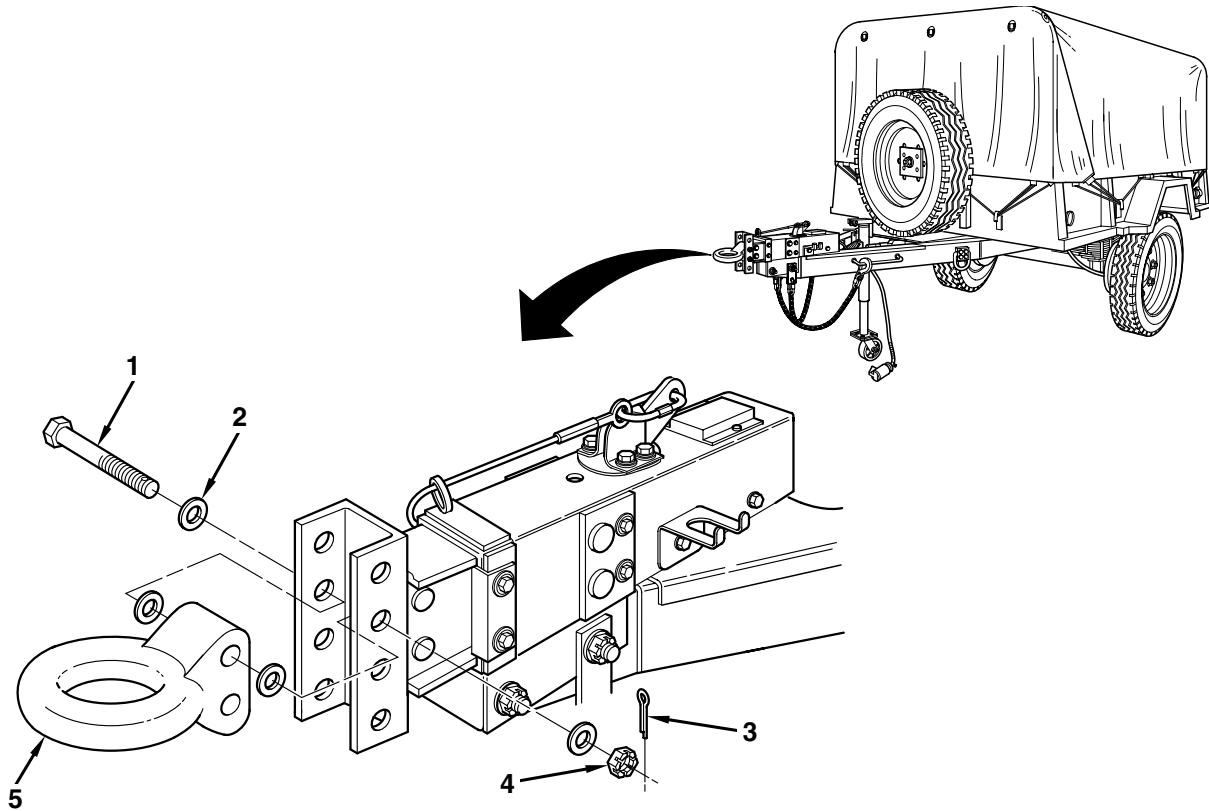

INSTALLATION

WARNING

Ensure that landing gear is lowered and locked and wheels are securely chocked. Failure to follow this warning may cause trailer to roll, resulting in injury to personnel or damage to equipment.

NOTE

Torque each nut (4) to 20 lb-ft (27.1 N•m) and then tighten to next hole for cotter pin (3).

Install drawbar coupler (5), eight (as necessary) flatwashers (2), two screws (1), nuts (4), and new cotter pins (3).

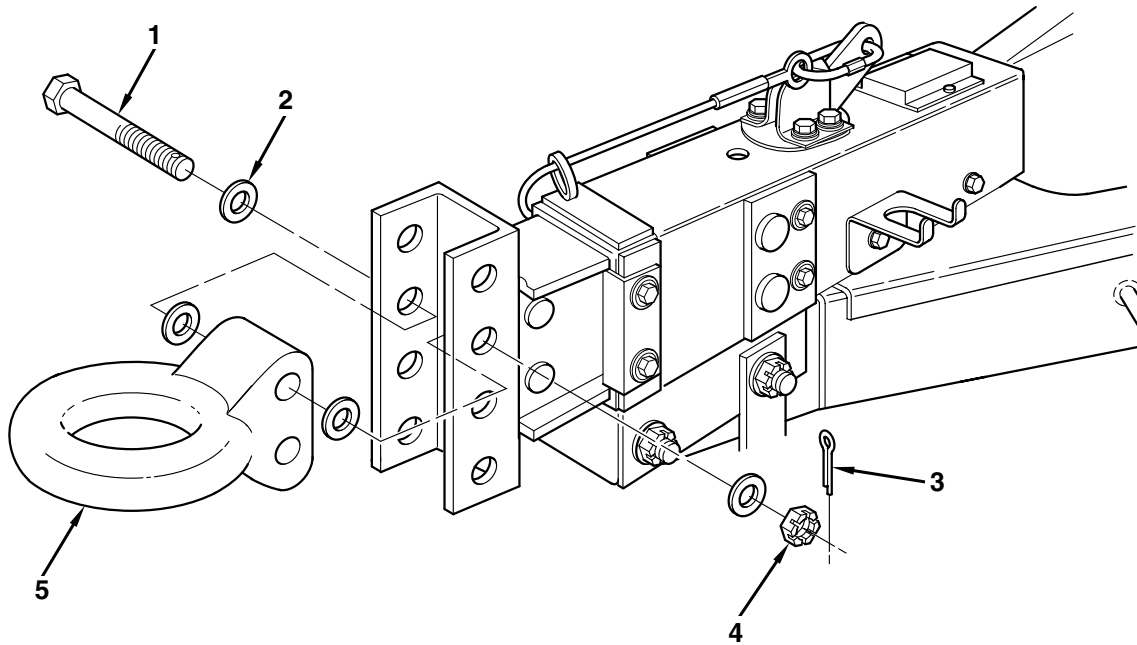

END OF TASK

SAFETY CHAIN REPLACEMENT

0042 00

THIS WP COVERS:

Removal, Installation

INITIAL SETUP:

Maintenance Level

Organizational

Tools and Special Tools

Tool Kit, General Mechanic's

Materials/Parts

Cotter Pin (Item 5, WP 0061 00)

REMOVAL

NOTE

- There are two safety chains and they are removed the same way. This procedure covers one safety chain.
- The breakaway cable is connected to the left safety chain and must be disconnected before removing the left safety chain.

1. Remove cotter pin (1), nut (2), flatwasher (3), screw (5), flatwasher (4), and safety chain (6). Discard cotter pin.

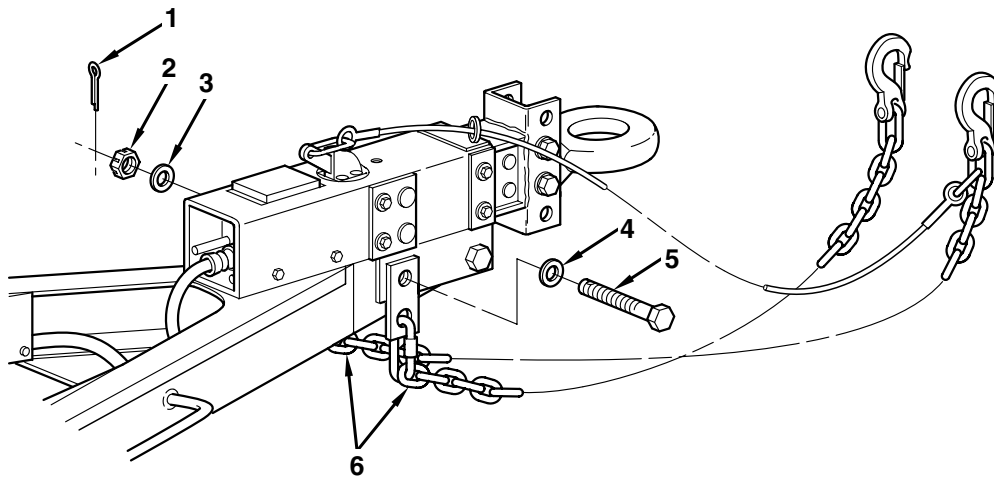

INSTALLATION

NOTE

- There are two safety chains and they are installed the same way. This procedure covers one safety chain.
- The breakaway cable must be reconnected to the left safety chain after installing the left safety chain.

1. Install safety chain (6), flatwasher (4), screw (5), flatwasher (3), nut (2), and new cotter pin (1).

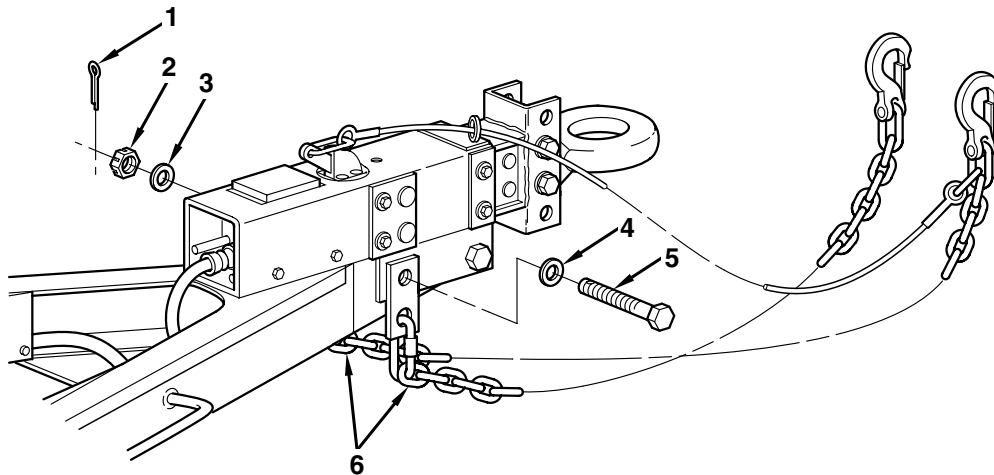

END OF TASK

LANDING GEAR MAINTENANCE

0043 00

THIS WP COVERS:

Removal, Cleaning, Inspection and Replacement, Installation

INITIAL SETUP:

Maintenance Level

Organizational

Tools and Special Tools

Floor Jack
 Jackstands (2)
 Tool Kit, General Mechanic's

Materials/Parts

Brush, Scrub (Item 1, WP 0060 00)
 Solvent, Cleaning (Item 10, WP 0060 00)
 Landing Gear (Item 26, WP 0061 00)
 Locknuts (2) (Items 21 & 22, WP 0061 00)
 Lockwashers (5) (Items 11 & 18, WP 0061 00)

REMOVAL

1. Raise trailer tongue with floor jack and position two jackstands under frame assembly (1). Remove floor jack.
2. Remove four nuts (18), lockwashers (19), flatwashers (20), screws (21), and caster (17). Discard lockwashers.
3. Remove locknut (3), flatwasher (4), bolt (6), flatwasher (5), spring (7), and handle (2). Discard locknut.
4. Disconnect spring (11). Remove screw (14), lockwasher (13), locknut (15), flatwasher (16), screw (10), flatwasher (9), release handle (12), and landing gear (8). Discard lockwasher, locknut, and landing gear.

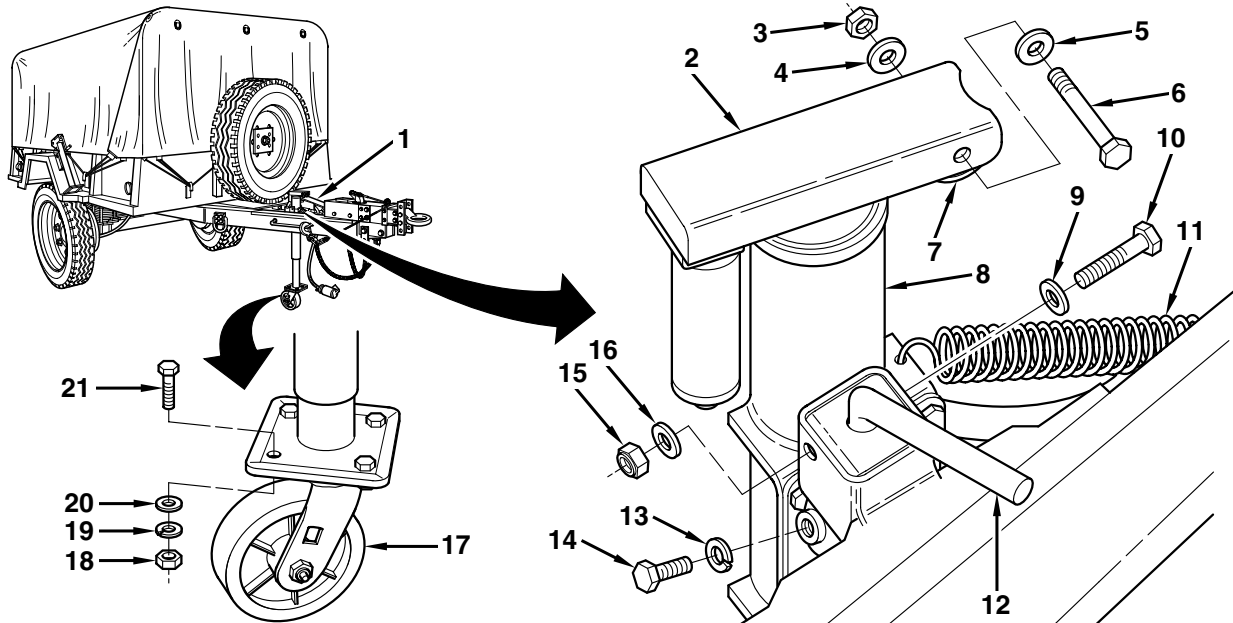

CLEANING

1. Remove dirt and mud with water and brush.

WARNING

Solvents can burn easily, can give off harmful vapors, and are harmful to skin and clothing. To avoid injury or death, keep away from open fire and use in a well-ventilated area. If solvent gets on skin or clothing, wash immediately with soap and water.

2. Remove grease and oil with cleaning solvent.

INSPECTION AND REPLACEMENT

Inspect parts for cracks, dents, rust, corrosion, or other damage. Repair or replace parts as required.

INSTALLATION

1. Install new landing gear (8), release handle (12), new lockwasher (13), screw (14), flatwasher (9), screw (10), flatwasher (16), and new locknut (15). Connect spring (5).
2. Install handle (2), spring (7), flatwasher (5), bolt (6), flatwasher (4), and new locknut (3).
3. Install caster (17), four screws (21), flatwashers (20), new lockwashers (19), and nuts (18).
4. Raise trailer tongue with floor jack and remove two jackstands and floor jack.

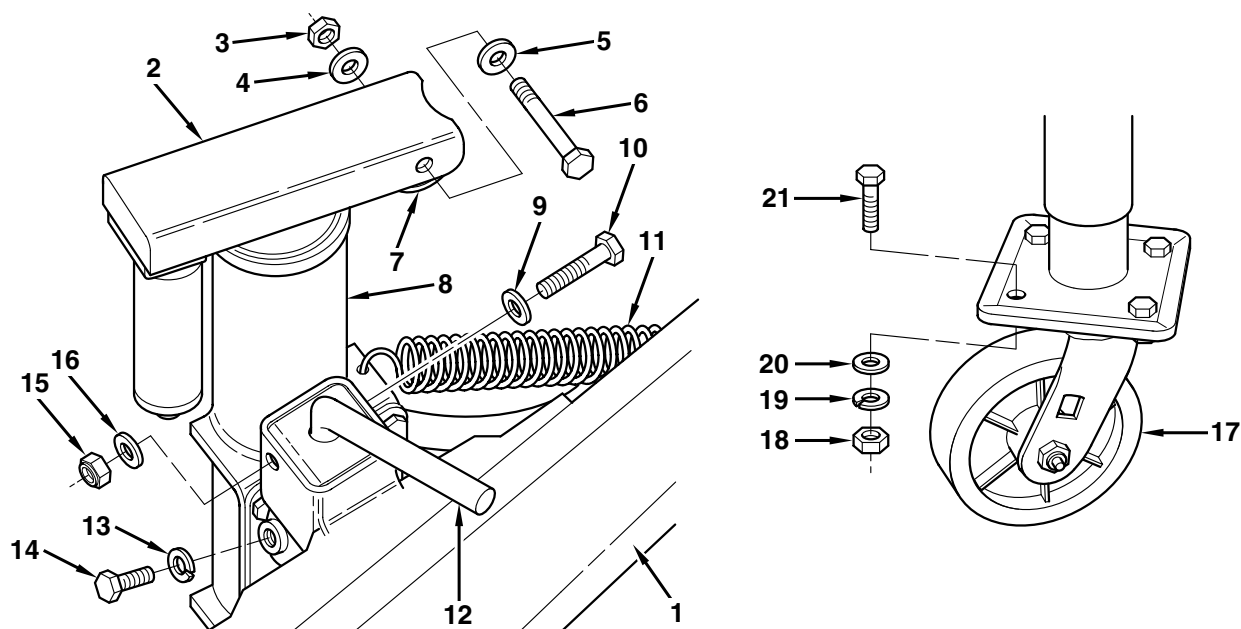

END OF TASK

SPRING MAINTENANCE

0044 00

THIS WP COVERS:

Removal, Cleaning and Inspection, Installation

INITIAL SETUP:

Maintenance Level

Organizational

Tools and Special Tools

Floor Jack
 Jackstand
 Tool Kit, General Mechanic's

Materials/Parts

Brush, Scrub (Item 1, WP 0060 00)
 Solvent, Cleaning (Item 10, WP 0060 00)
 Locknuts (44) (Items 19 & 20, WP 0061 00)

Personnel

Two

References

WP 0023 00

Equipment Conditions

Wheel Removed (WP 0020 00)

REMOVAL

NOTE

Right and left springs are removed the same way. This procedure covers one spring.

1. Position trailer on level surface with front end resting on landing gear. Raise side of trailer with rear jack and place a jackstand on corner of rear crossmember. Lower and remove rear jack.

REMOVAL—Continued

2. Place floor jack under axle just enough to support weight of axle.
3. Remove four locknuts (19), two U-bolts (28), plates (18 and 32), and auxiliary spring (33) from spring (31). Discard locknuts.
4. Lower floor jack enough to give 1 in. (2.5 cm) clearance between spring (31) and axle.
5. Remove grease fitting (27), two locknuts (25), flatwashers (24), screws (23), and pin (26) from spring shackle (21). Discard locknuts.
6. Remove grease fitting (22), locknut (10), flatwasher (9), screw (7), pin (20), and spring shackle (21) from spring hanger (8). Discard locknut.
7. Remove grease fitting (29), locknut (14), flatwasher (15), and screw (17) from spring hanger (16). Discard locknut.
8. Tap pin (30) out of spring hanger (16). Remove spring (31).
9. Remove eight locknuts (2), flatwashers (1), screws (6), flatwashers (5), and two spring hangers (8 and 16). Discard locknuts.
10. Remove six locknuts (3), flatwashers (4), screws (12), flatwashers (13), and two brackets (11). Discard locknuts.

REMOVAL—Continued

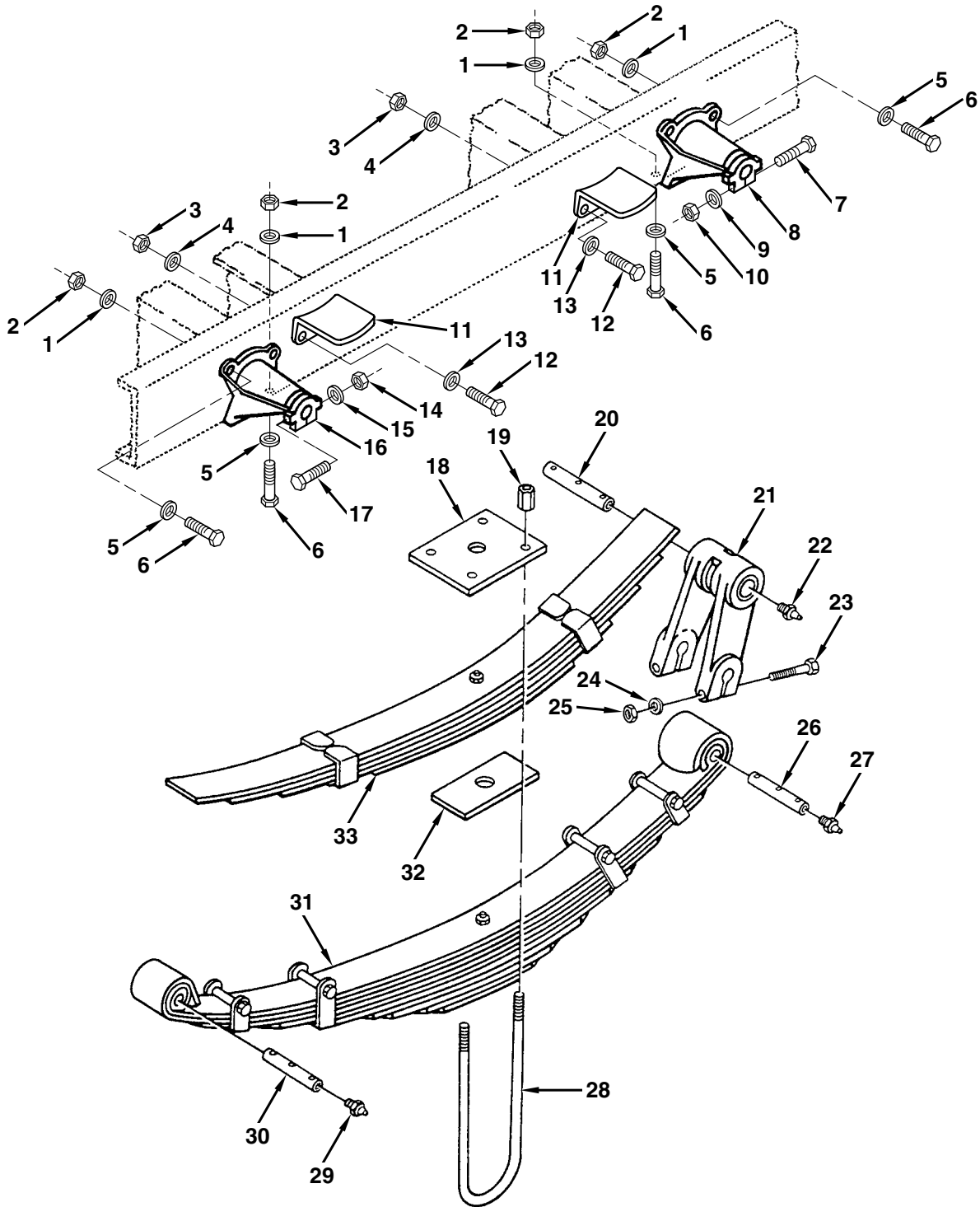

CLEANING AND INSPECTION**WARNING**

Solvents can burn easily, can give off harmful vapors, and are harmful to skin and clothing. To avoid injury or death, keep away from open fire and use in a well-ventilated area. If solvent gets on skin or clothing, wash immediately with soap and water.

1. Clean all parts with cleaning solvent. Dry thoroughly.
2. Inspect for loose, missing, or damaged hardware.
3. Inspect spring for cracks, breaks, and excessive wear.
4. Inspect for rust or corrosion.
5. Replace spring if defective or excessive wear is apparent.

INSTALLATION**NOTE**

Right and left springs are installed the same way. This procedure covers one spring.

1. Install two brackets (11), six flatwashers (13), screws (12), flatwashers (4), and new locknuts (3).
2. Install two spring hangers (8 and 16), eight flatwashers (5), screws (6), flatwashers (1), and new locknuts (2).
3. Position spring (31) at spring hanger (16) and tap in pin (30), aligning groove for screw (17).
4. Install screw (17), flatwasher (15), new locknut (14), and grease fitting (29) to spring hanger (16).
5. Position spring shackle (21) at spring hanger (8) and install pin (20) with groove aligned for screw (7). Install screw, flatwasher (9), new locknut (10), and grease fitting (22).
6. Position spring (31) in shackle (21) on spring hanger (8). Tap pin (26) in shackle.
7. Install two screws (23), flatwashers (24), new locknuts (25), and grease fitting (27) in shackle (21).
8. Raise axle with floor jack enough to align axle with spring (31).
9. Position plates (18 and 32) and auxiliary spring (33) on spring (31) and install two U-bolts (28) and four new locknuts (19). Tighten nuts to a torque of 223 lb-ft (302 N•m).
10. Lower and remove floor jack. Install rear jack and remove jackstand.

INSTALLATION—Continued

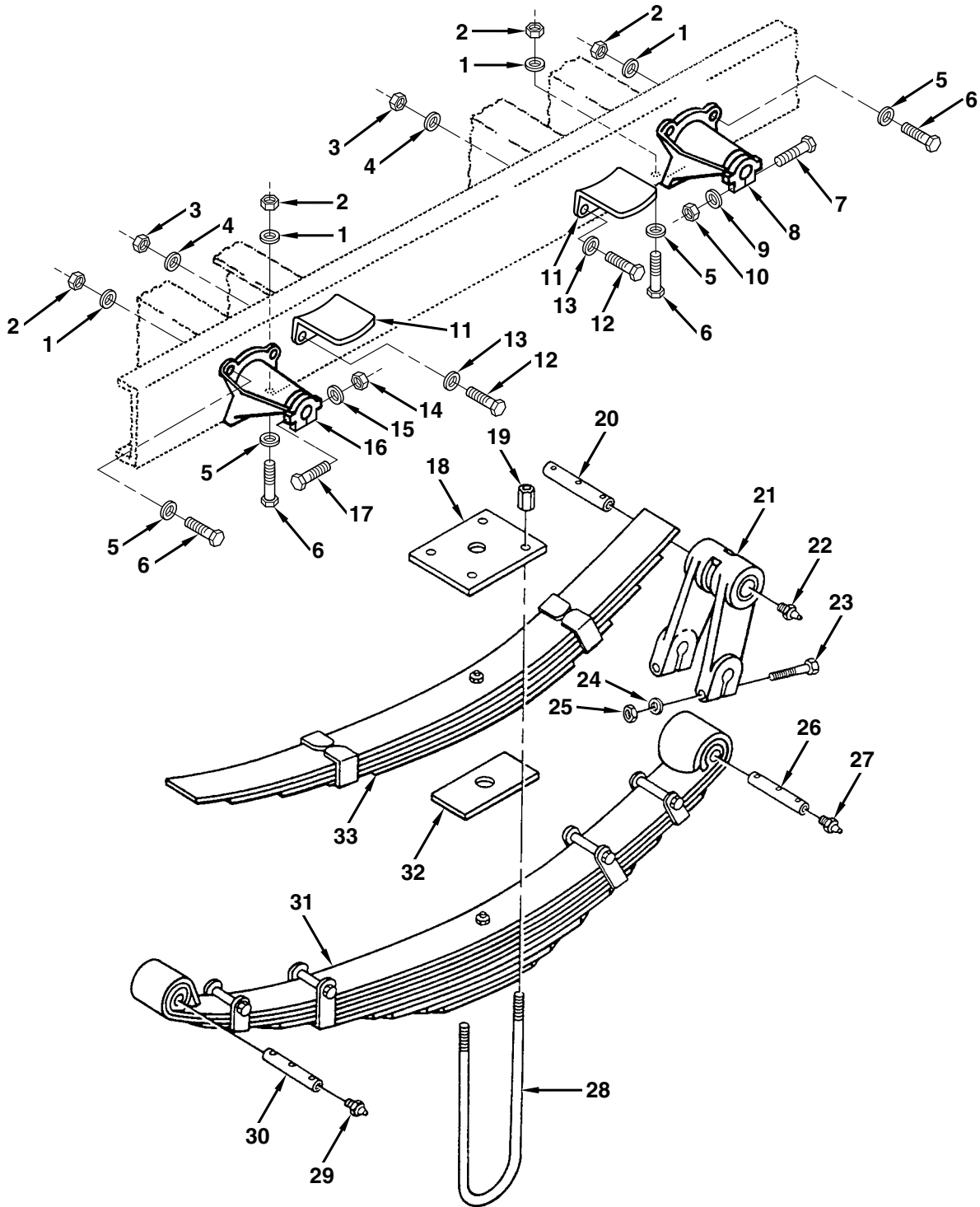

SPRING MAINTENANCE—Continued

0044 00

FOLLOW-ON TASKS

1. Lubricate spring pins (WP 0023 00).
2. Install wheel (WP 0020 00).

END OF TASK

CARGO TIEDOWN REPLACEMENT

0045 00

THIS WP COVERS:
Removal, Installation

INITIAL SETUP:
Maintenance Level
Organizational

Tools and Special Tools
Tool Kit, General Mechanic's

Materials/Parts
Lockwashers (24) (Item 17, WP 0061 00)

REMOVAL

NOTE

There are six cargo tiedowns (2) and they are removed the same way.
This procedure covers one cargo tiedown.

Remove four nuts (5), lockwashers (4), flatwashers (3), screws (1), and cargo tiedown (2). Discard lockwashers.

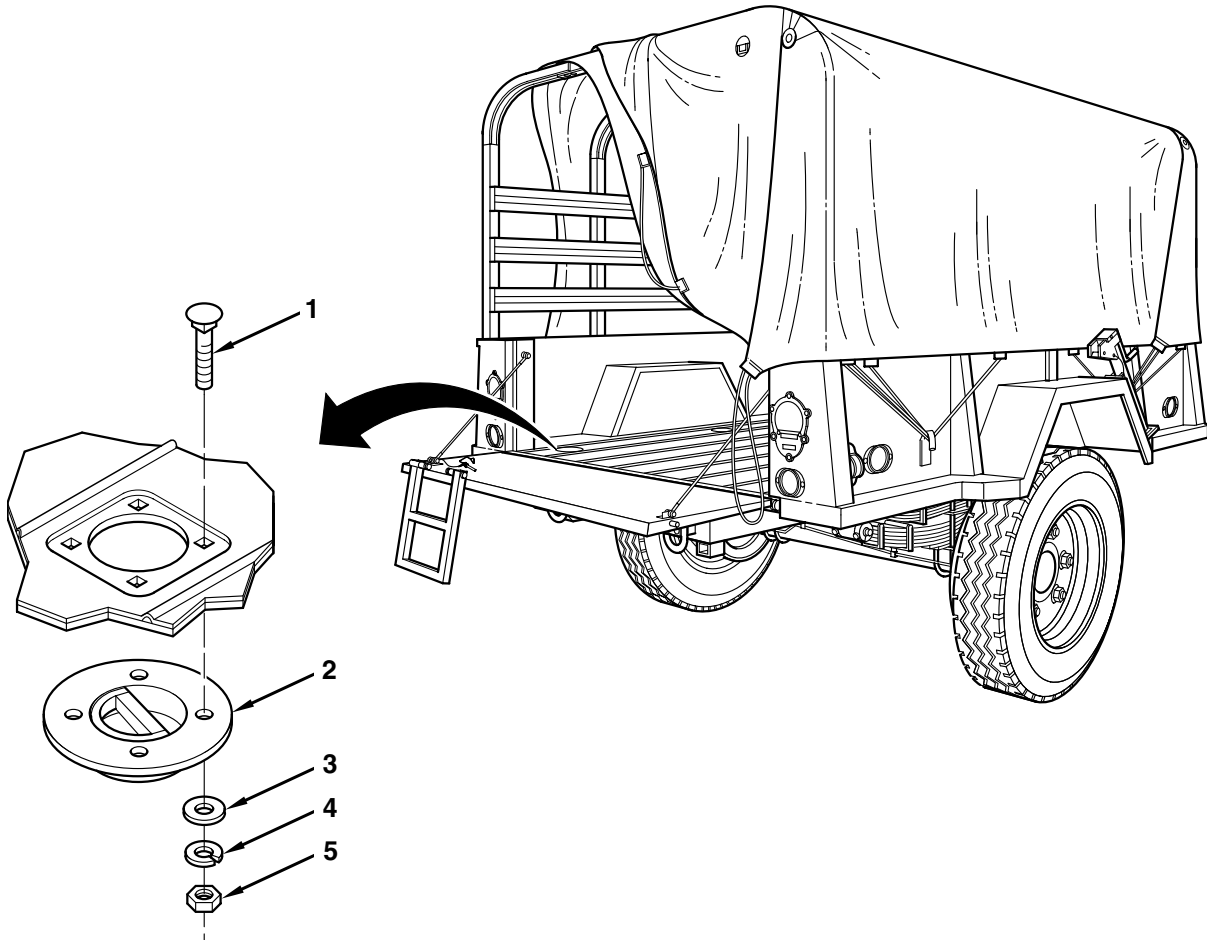

INSTALLATION

NOTE

There are six cargo tiedowns (2) and they are installed the same way. This procedure covers one cargo tiedown.

Install cargo tiedown (2), four screws (1), flatwashers (3), new lockwashers (4), and nuts (5).

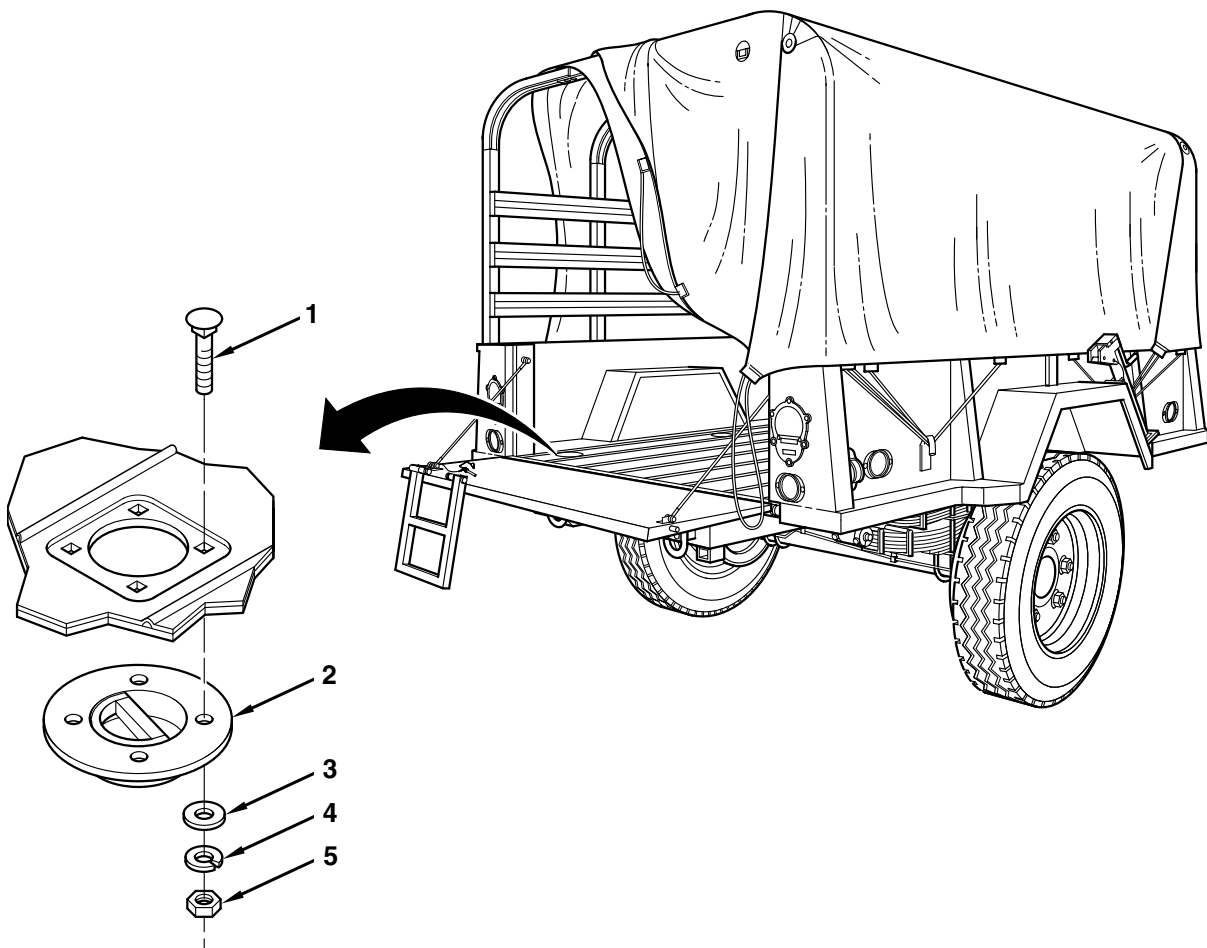

END OF TASK

TAILGATE REPLACEMENT

0046 00

THIS WP COVERS:

Removal, Installation

INITIAL SETUP:

Maintenance Level

Organizational

Tools and Special Tools

Tool Kit, General Mechanic's

Materials/Parts

Cotter Pins (4) (Item 6, WP 0061 00)
Locknuts (12) (Items 12, 21, 22 & 23,
WP 0061 00)

Personnel

Two

Equipment Conditions

Composite Lights Removed (WP 0026 00)

REMOVAL

1. Remove two locknuts (3), screws (1), six flatwashers (2), and ladder (4). Discard locknuts.

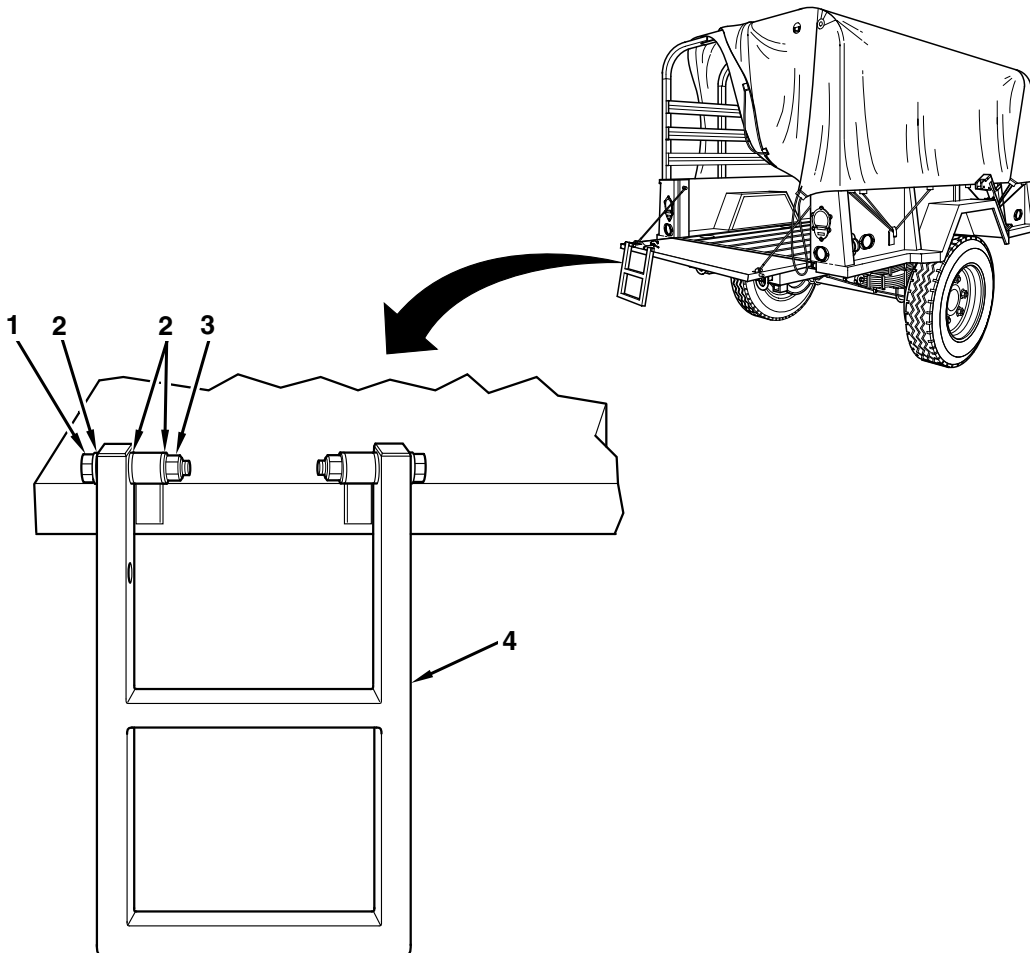

REMOVAL—Continued

NOTE

- Assistance is required to support tailgate (13) for steps 2 through 4.
 - There is a lockpin (6) on the left side of the tailgate only.
2. Support tailgate (13) in open position and remove locknut (5), three flatwashers (8), screw (9), lockpin (6), and disconnect safety cable (7). Discard locknut.
 3. Remove locknut (10), three flatwashers (11), screw (12), and safety cable (7). Discard locknut.

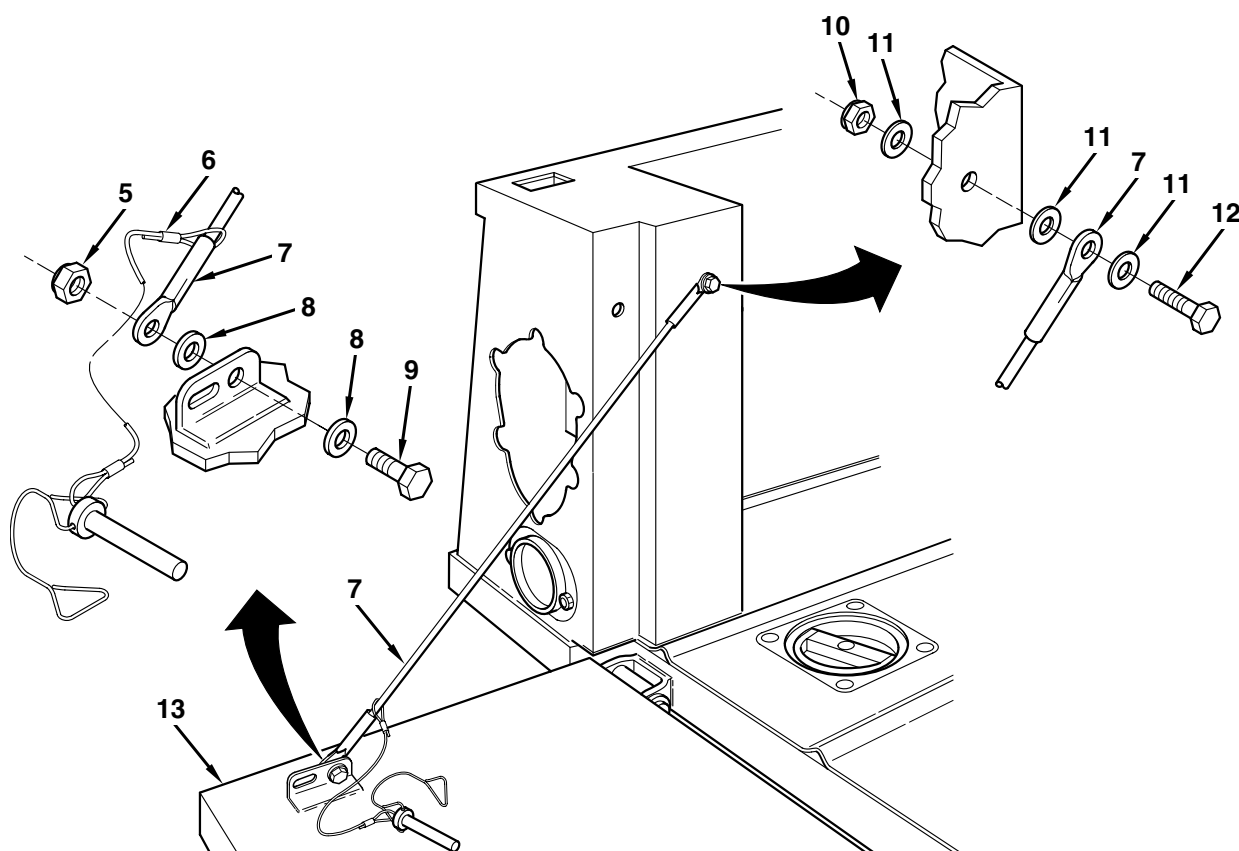

4. Repeat steps 2 and 3 for other side.

REMOVAL—Continued

NOTE

Assistance is required to support and remove tailgate (13) for step 5.

5. Support tailgate (13) in closed position and remove four cotter pins (22), pins (23), and tailgate. Discard cotter pins.
6. Remove two locknuts (14), four flatwashers (15), two bolts (17), and latches (16). Discard locknuts.
7. Remove four screws (18), lockwashers (19), flatwashers (20), and two hinges (21). Discard lockwashers.

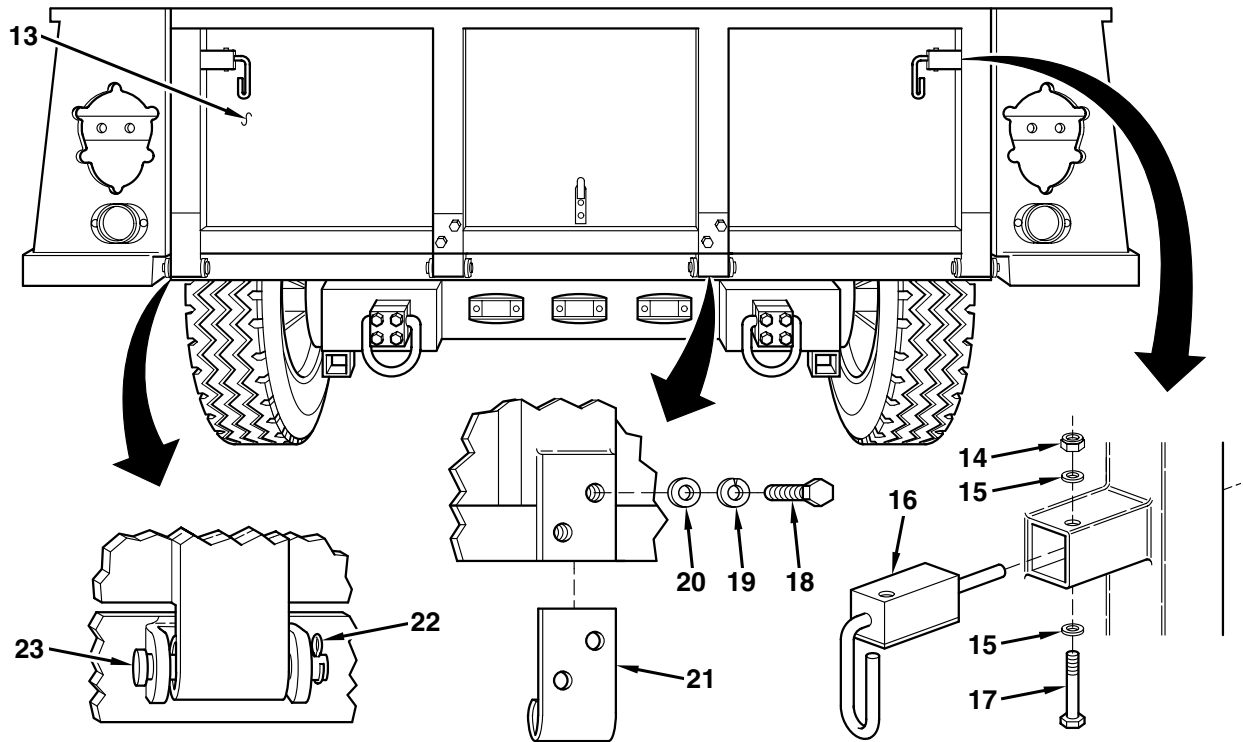

INSTALLATION

1. Install two hinges (21), four new flatwashers (20), lockwashers (19), and screws (18).
2. Install two latches (16), four flatwashers (15), two bolts (17), and new locknuts (14).

NOTE

Assistance is required to support tailgate (13) for step 3.

3. Support tailgate (13) in closed position and install four pins (23) and new cotter pins (22).

INSTALLATION—Continued

NOTE

- Assistance is required to support tailgate (13) for steps 4 through 6.
- There is a lockpin (6) on the left side of the tailgate only.

4. Support tailgate in open position and connect safety cable (7) by installing screw (9), three flatwashers (8), lockpin (7), and new locknut (5).

NOTE

Twist safety cable (7) 1 time before installing to prevent interference with cargo box when closing tailgate.

5. Install safety cable (7), screw (12), three flatwashers (11), and new locknut (10).

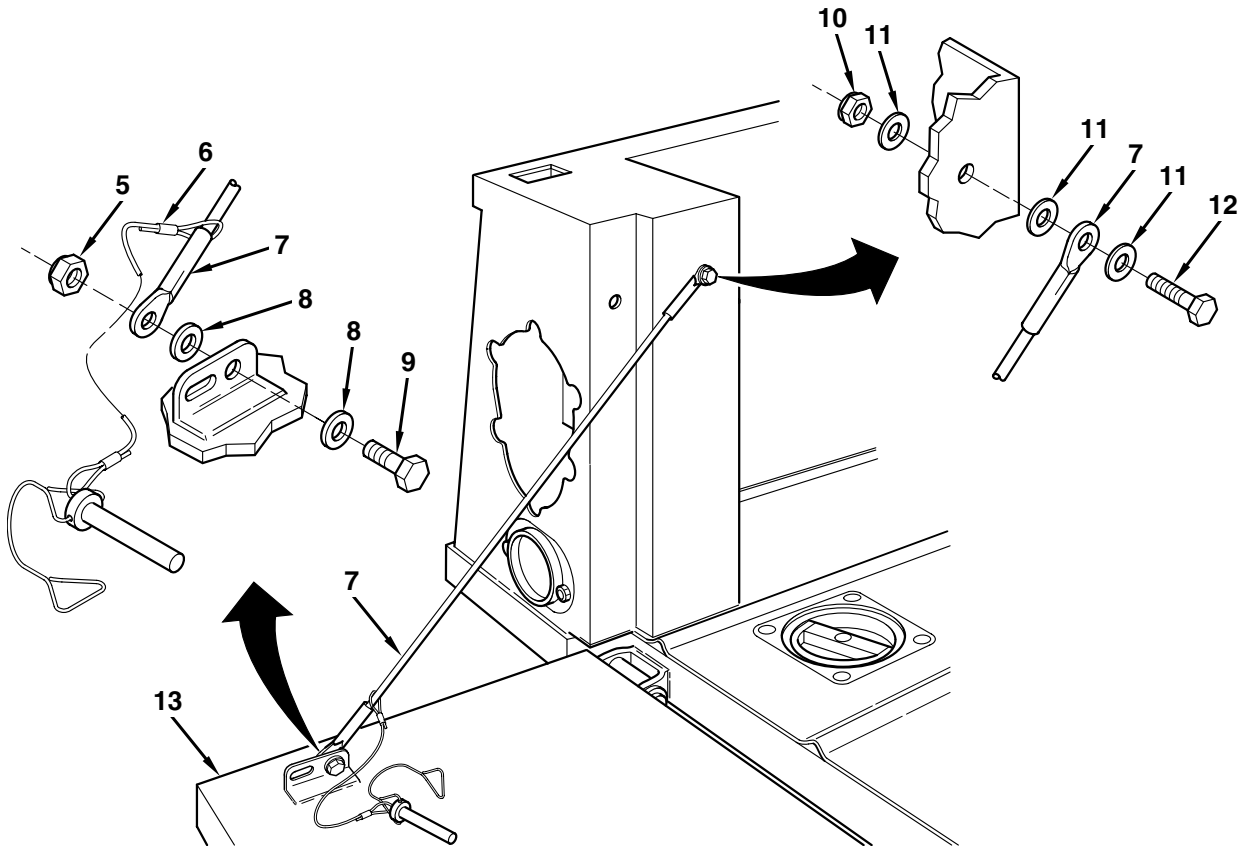

6. Repeat steps 4 and 5 for other side.

INSTALLATION—Continued

7. Install ladder (4), two screws (1), six flatwashers (2), and two new locknuts (3).

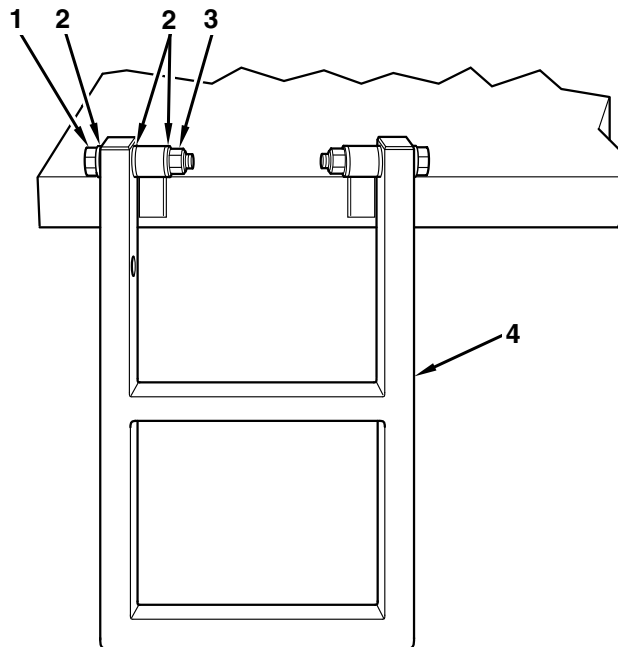

FOLLOW-ON TASK

Install composite lights (WP 0026 00).

END OF TASK

SPARE WHEEL RACK MAINTENANCE

0047 00

THIS WP COVERS:

Removal, Installation, Adjustment

INITIAL SETUP:

Maintenance Level

Organizational

Tools and Special Tools

Tool Kit, General Mechanic's

Materials/Parts

Lockwashers (4) (Item 17, WP 0061 00)

Equipment Conditions

Spare Wheel Removed (WP 0020 00)

Personnel

Two

REMOVAL

Remove four nuts (3), lockwashers (2), screws (4), and hub support (1).

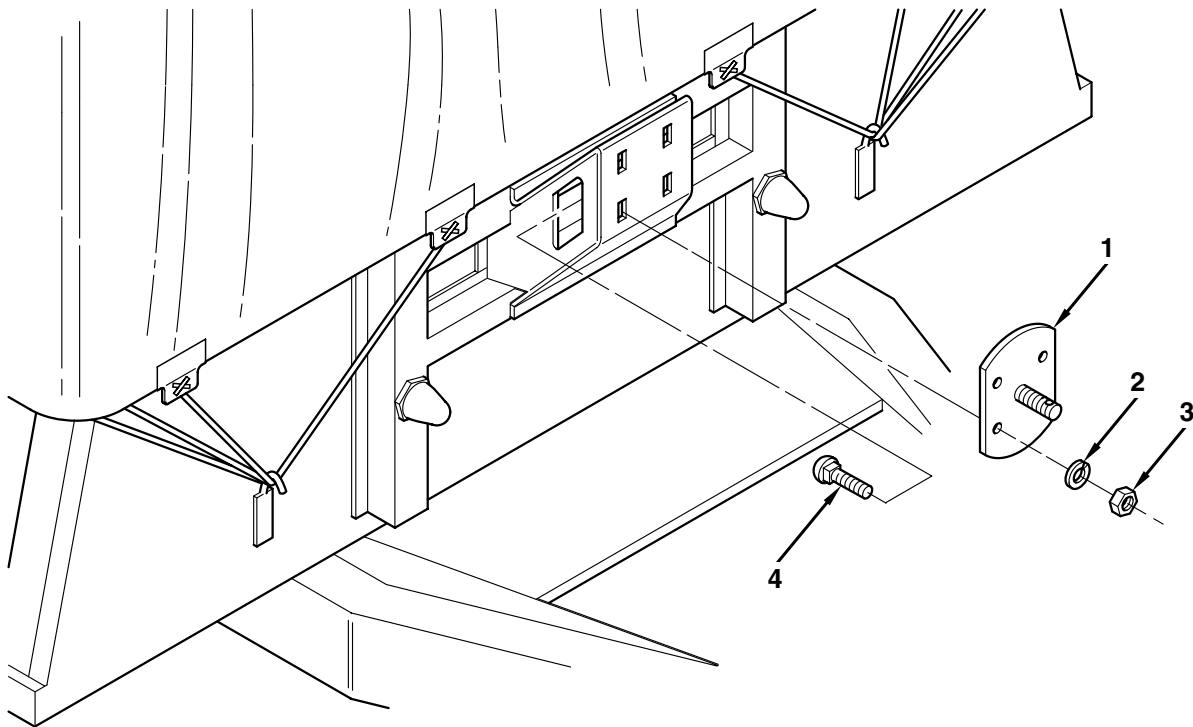

INSTALLATION

Install hub support (1), four screws (4), new lockwashers (2), and nuts (3).

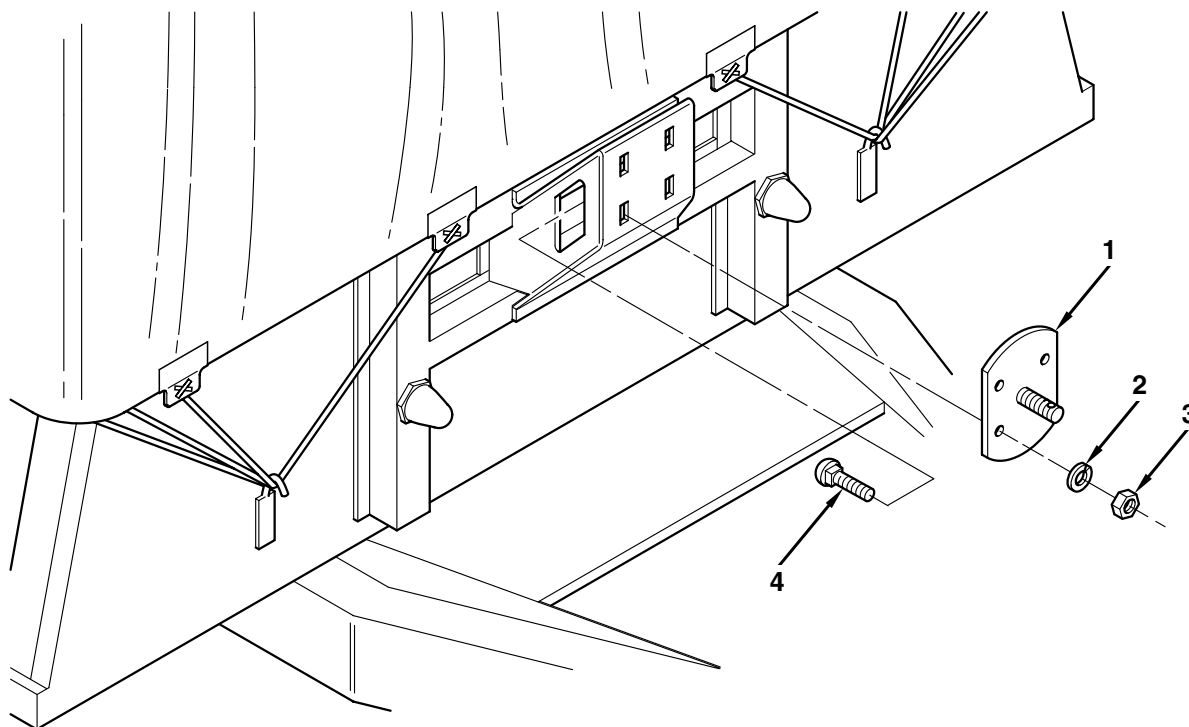
**ADJUSTMENT**

1. Loosen but do not remove four nuts (3).

WARNING

Spare wheel weighs 185 lb (84 kg). Use two people to hold spare wheel in place during adjustment. Failure to follow this warning could result in injury to personnel.

2. Holding spare wheel in place, adjust hub support (1) so that it fits in center hole in spare wheel. Tighten four nuts (3).

FOLLOW-ON TASK

Install spare wheel (WP 0020 00).

END OF TASK

D-RING REPLACEMENT

0048 00

THIS WP COVERS:

Removal, Installation

INITIAL SETUP:

Maintenance Level

Organizational

Tools and Special Tools

Tool Kit, General Mechanic's

Materials/Parts

Locknuts (16) (Item 24, WP 0061 00)

REMOVAL

NOTE

There are four D-rings (4) and they are removed the same way. This procedure covers one D-ring.

Remove four locknuts (5), screws (3), eight flatwashers (2), retaining block (1), and D-ring (4). Discard locknuts.

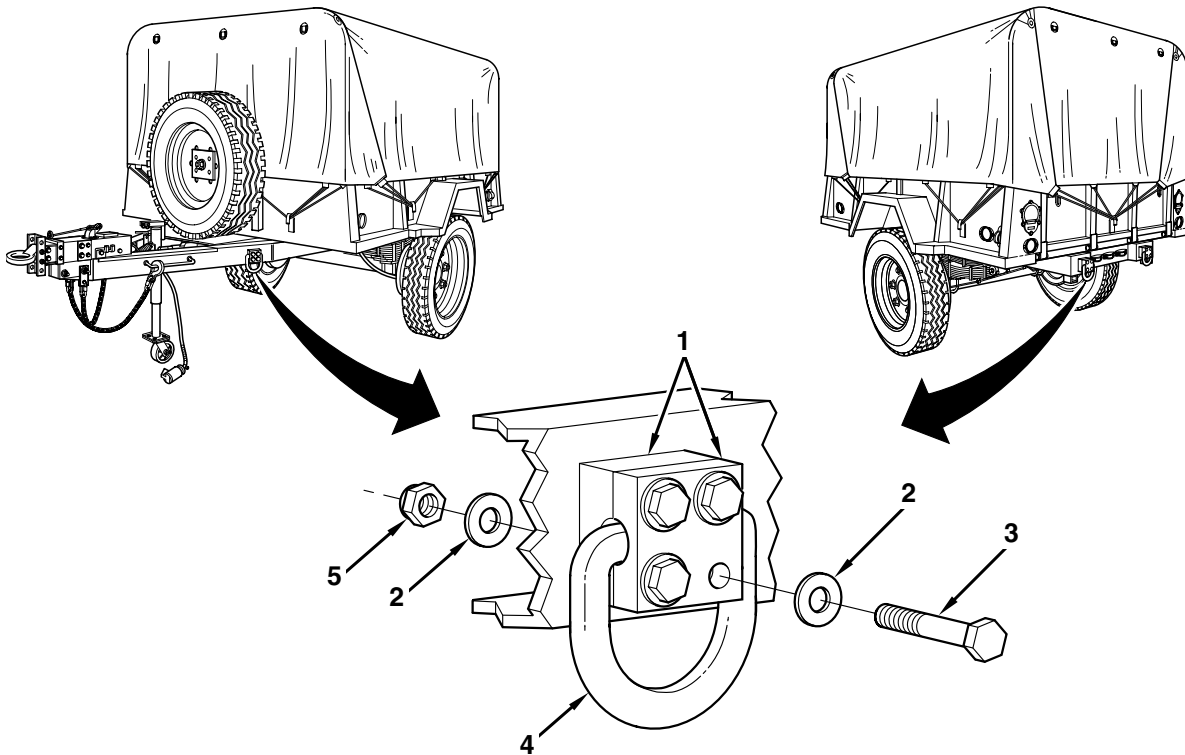

INSTALLATION

NOTE

- There are four D-rings (4) and they are installed the same way. This procedure covers one D-ring.
- Install thicker segment of retaining block (1) on inside.

Install D-ring (4), retaining block (1), eight flatwashers (2), four screws (3), and new locknuts (5). Tighten screws to a torque of 80 lb-ft (108 N•m).

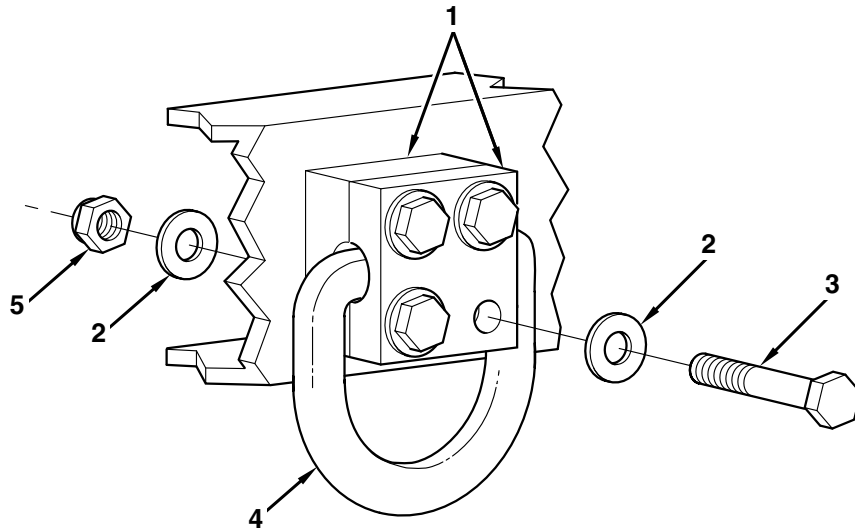

END OF TASK

REFLECTOR REPLACEMENT

0049 00

THIS WP COVERS:

Removal, Installation

INITIAL SETUP:

Maintenance Level

Organizational

Tools and Special Tools

Tool Kit, General Mechanic's

Materials/Parts

Lockwashers (12) (Item 16, WP 0061 00)

Equipment Conditions

Composite Lights Removed (WP 0026 00)

REMOVAL

NOTE

There are six reflectors (3) (four red and two amber) and they are removed the same way. This procedure covers one reflector.

Remove two nuts (5), lockwashers (4), screws (1), flatwashers (2), and reflector (3). Discard lockwashers.

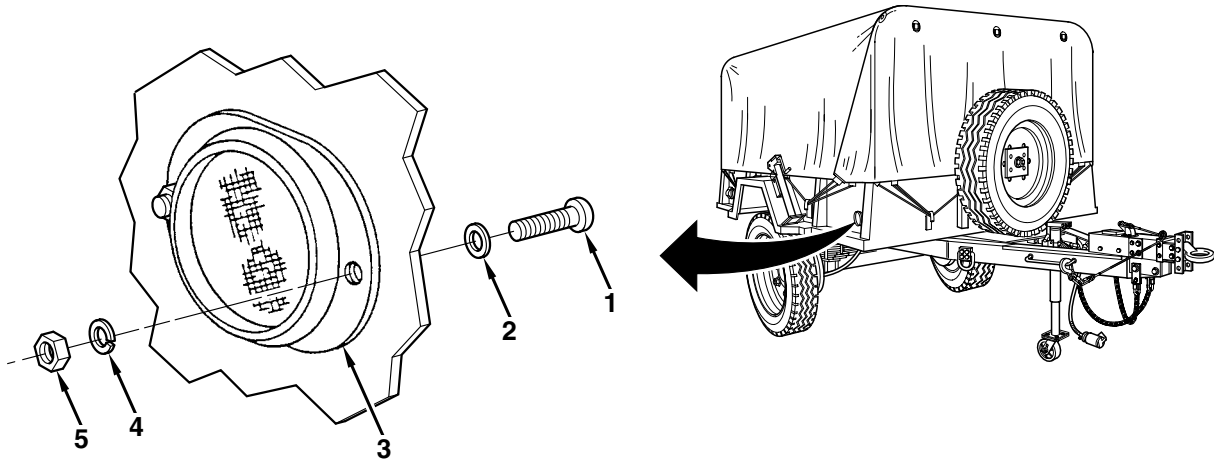

INSTALLATION

NOTE

- **There are six reflectors (3) (four red and two amber) and they are installed the same way. This procedure covers one reflector.**
- **Install two amber reflectors on right-front side and left-front side.**

Install reflector (3), two flatwashers (2), screws (1), new lockwashers (4), and nuts (5).

REFLECTOR—Continued

0049 00

FOLLOW-ON TASK

Install composite lights (WP 0026 00).

END OF TASK

DATA PLATE REPLACEMENT

0050 00

THIS WP COVERS:

Removal, Installation

INITIAL SETUP:

Maintenance Level

Organizational

Tools and Special Tools

Tool Kit, General Mechanic's

Materials/Parts

Rivets (8) (Item 3, WP 0061 00)

REMOVAL

Remove eight rivets (1) and data plate (2).

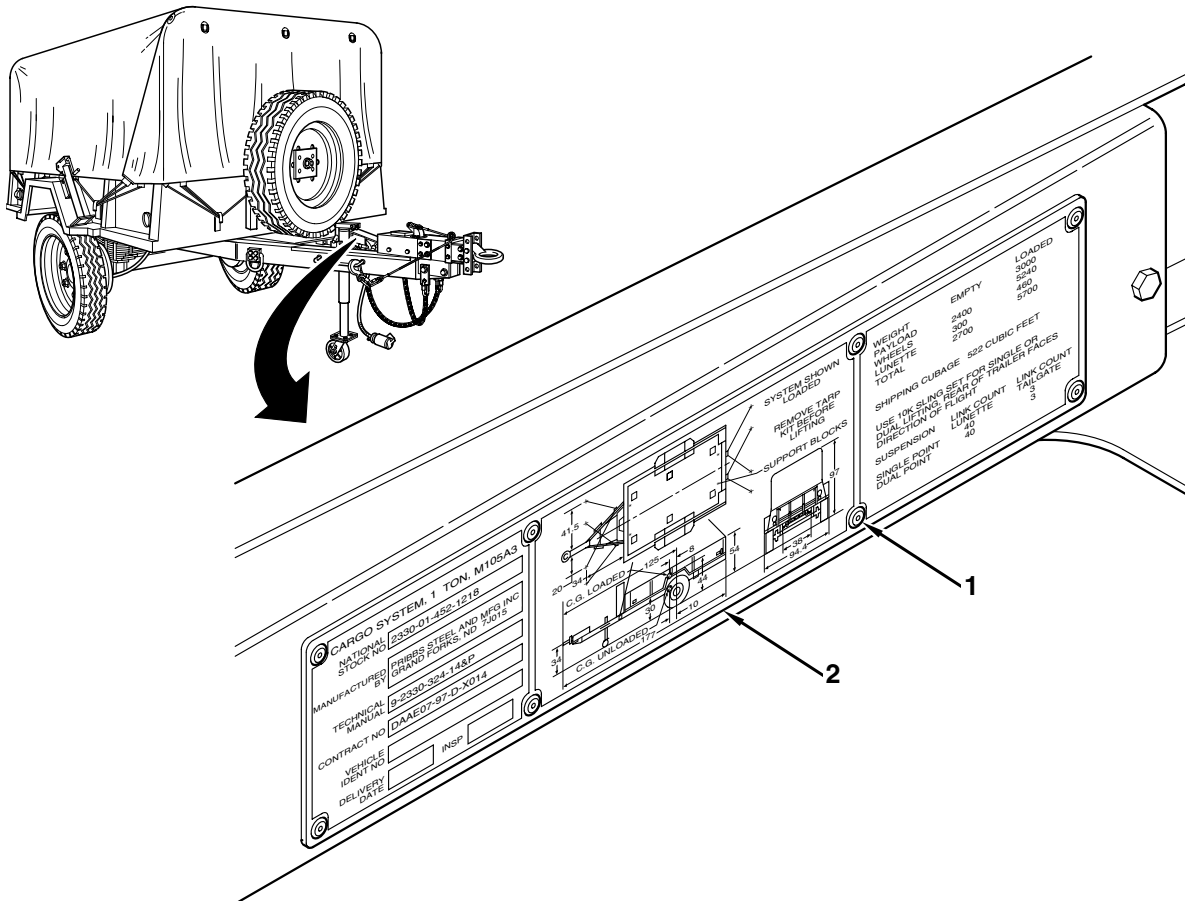

INSTALLATION

Install data plate (2) and eight rivets (1).

END OF TASK

PREPARATION FOR STORAGE OR SHIPMENT

0051 00

THIS WP COVERS:Storage, Shipment

INITIAL SETUP:**Maintenance Level**

Organizational

References

TB 43-0209

TM 55-21

References—Cont.

TM 55-601

TM 743-200-1

WP 0018 00

WP 0021 00

WP 0023 00

GENERAL

This section contains requirements and procedures for administrative storage of equipment that is issued to and in use by Army activities worldwide.

The requirements specified herein are necessary to maintain equipment in administrative storage in such a way as to achieve the maximum readiness condition.

Equipment that is placed in administrative storage should be capable of being readied to perform its mission within a 24-hour period, or as otherwise may be prescribed by the approving authority. Before equipment is placed in administrative storage, a current Preventive Maintenance Checks and Services (PMCS) must be completed and deficiencies corrected.

Report equipment in administrative storage as prescribed for all reportable equipment.

Perform inspections, maintenance services, and lubrication as specified herein.

Records and reports to be maintained for equipment in administrative storage are those prescribed by DA PAM 738-750 for equipment in use.

A 10% variance is acceptable on time, running hours, or mileage used to determine the required maintenance actions.

Accomplishment of applicable PMCS, as mentioned throughout this WP, will be on a quarterly basis.

DEFINITION OF ADMINISTRATIVE STORAGE

The placement of equipment in administrative storage can be for short periods of time when a shortage of maintenance effort exists. Items should be ready for use within the time factors as determined by the directing authority. During the storage period, appropriate maintenance records will be kept.

PREPARATION OF EQUIPMENT FOR ADMINISTRATIVE STORAGE**Storage Site**

1. Select the best available site for administrative storage. Separate stored equipment from equipment in use. Conspicuously mark the area "ADMINISTRATIVE STORAGE."

Storage Site—Continued

2. Covered space is preferred. When sufficient covered space for all items to be stored is not available, priority should be given to items which are most susceptible to deterioration from the elements. SB 740-98-1 should be used as a guide for establishing which items are most susceptible to deterioration.
3. Open sites should be improved hardstand, if possible. Unimproved sites should be firm, well-drained, and kept free of excessive vegetation.

Storage Plan

1. Store equipment so as to provide maximum protection from the elements and to provide access for inspection, maintenance, and exercising. Anticipate removal or deployment problems and take suitable precautions.
2. Take into account environmental conditions, such as extreme heat or cold, high humidity, blowing sand or loose debris, soft ground, mud, heavy snow, and take adequate precautions
3. Establish a fire plan and provide for adequate firefighting equipment and personnel.

Maintenance Services and Inspection

1. Prior to storage, perform the next scheduled organizational PMCS.
2. Inspect and approve the equipment prior to storage. Do not place equipment in storage in a nonmission-capable condition.
3. Lubricate equipment in accordance with applicable lubrications instructions located at WPs 0018 00 and 0023 00.

Additional Authorization List (AAL) Items

1. Process AAL items simultaneously with the major item to which they are assigned.
2. If possible, store AAL items with the major item.
3. If stored apart from the major item, mark AAL items with tags indicating the major item, its registration or serial number, and location, and store in protective-type closures. In addition, place a tag or list indicating the location of the removed items in a conspicuous place on the major item.

Correction of Shortcomings and Deficiencies

Correct all shortcomings and deficiencies prior to storage, or obtain a waiver from the approving authority.

General Cleaning, Painting, and Preservation

CAUTION

Do not direct water or steam, under pressure, against electrical wires or any exterior opening. Failure to follow this caution may result in damage to equipment.

General Cleaning, Painting, and Preservation—Continued

1. Clean all equipment of dirt, grease, and other contaminants in accordance with applicable provisions of this manual. Do not use vapor degreasing. Remove foreign objects that are wedged in tire treads.
2. Remove rust and damaged paint by scraping, wire brushing, sanding, or buffing. Sand to a smooth finish and spot paint as necessary. Refer to TB 43-0209 and TM 43-0139.
3. After cleaning and drying, immediately coat unpainted metal surfaces with oil or grease, as appropriate (WPs 0018 00 and 0023 00).

NOTE

Air circulation under draped covers reduces deterioration from moisture and heat.

4. Place equipment and provide blocking or framing to allow ventilation and water drainage. Support cover away from item surfaces, which may rust, rot, or mildew.

CARE OF EQUIPMENT IN ADMINISTRATIVE STORAGE

Maintenance Services

After equipment has been placed in administrative storage, inspect, service, and exercise as specified in this manual. Refer to DA PAM 710.

Inspection

Inspection will usually be visual and must consist of at least a walk-around examination of all equipment to detect any deficiencies. Inspect equipment in open storage weekly and equipment in covered storage monthly. Inspect all equipment immediately after any severe storm or environmental change. The following are examples of things to look for during a visual inspection:

1. Low or flat tires
2. Condition of preservatives, seals, and wraps
3. Torn, frayed, or split canvas covers and tops
4. Corrosion or other deterioration
5. Missing or damaged parts
6. Water in components
7. Any other readily recognizable shortcomings or deficiencies

Repair During Administrative Storage

Keep equipment in an optimum state of readiness. Accomplish the required services and repairs as expeditiously as possible. Whenever possible, perform all maintenance on-site.

PREPARATION FOR STORAGE OR SHIPMENT—Continued

0051 00

Exercising

Exercise equipment in accordance with Table 1, Exercise Schedule, and the following instructions:

1. **Vehicle Major Exercise.** Depreserve equipment by removing only that material restricting exercise. Close all drains, remove blocks, latch tailgates, and perform all before-operation checks. Couple trailer to towing vehicle, and drive for at least 25 miles (40 km/h). Make several right and left 90° turns. Make several hard braking stops without skidding. Do the following during exercising when it is convenient and safe: operate all other functional components and perform all during- and after-operation checks.
2. **Scheduled Services.** Scheduled services will include inspection per “Inspection” above, and will be conducted in accordance with Table 1, Exercise Schedule. Lubricate in accordance with instructions in WPs 0018 00 and 0023 00.
3. **Corrective Action.** Immediately take action to correct shortcomings and deficiencies noted. Record inspection and exercise results on DA Form 2404/DA Form 5988/E. Record and report all maintenance actions on DA Form 2407. After exercising, restore the preservation to the original condition.

Table 1. Exercise Schedule.

Weeks	2	4	6	8	10	12	14	16	18	20	22	24
PMCS						X						X
Scheduled Services		X		X		X		X		X		
Major Exercise												X

Rotation

To ensure utilization of all assigned materiel, rotate items in accordance with rotational plan that will keep equipment in operational condition and reduce maintenance efforts.

PROCEDURES FOR COMMON COMPONENTS AND MISCELLANEOUS ITEMS

Tires

Visually inspect tires during each walk-around inspection. This inspection includes checking tires with a tire gage. Inflate, repair, or replace as necessary those found to be low, damaged, or excessively worn. Mark inflated and repaired tires with a crayon for checking at the next inspection.

Seals

Seals may develop leaks during storage, or shortly thereafter. If leaking persists, refer to the applicable maintenance section in this manual for corrective maintenance procedures.

REMOVAL OF EQUIPMENT FROM ADMINISTRATIVE STORAGE

Activation

Restore the equipment to normal operating condition in accordance with the instructions contained in WP 0021 00.

REMOVAL OF EQUIPMENT FROM ADMINISTRATIVE STORAGE—Continued

Servicing

Resume the maintenance service schedule in effect at the commencement of storage, or service the equipment before the scheduled dates in order to produce a staggered maintenance workload.

PREPARATION OF EQUIPMENT FOR SHIPMENT

Refer to TM 55-21 and TM 55-601 for additional instructions on processing, storage, and shipment of materiel.

Trailers that have been removed from storage for shipment do not have to be reprocessed if they will reach their destination within the administrative storage period. Reprocess only if inspection reveals any corrosion, or if anticipated in-transit weather conditions make it necessary.

When a trailer is received that has already been processed for domestic shipment, as indicated on DD Form 1397, the trailer does not have to be reprocessed for storage unless corrosion and deterioration are found during the inspection upon receipt. List on SF 364 all discrepancies found because of poor preservation, packaging, packing, marking, handling, loading, storage, or excessive preservation. Repairs that cannot be handled by the receiving unit must have tags attached listing needed repairs. A report of these conditions will be submitted by the unit commander for action by an ordnance maintenance unit.

END OF TASK

CHAPTER 7
DIRECT SUPPORT AND GENERAL SUPPORT
MAINTENANCE INSTRUCTIONS
FOR
M105A3 CARGO TRAILER

AXLE REPLACEMENT

0052 00

THIS WP COVERS:

Removal, Cleaning, Inspection and Repair, Installation

INITIAL SETUP:

Maintenance Level

Direct Support and General Support

Materials/Parts

Brush, Scrub (Item 1, WP 0060 00)
 Rags, Wiping (Item 9, WP 0060 00)
 Solvent, Cleaning (Item 10, WP 0060 00)
 Locknuts (8) (Item 25, WP 0061 00)
 Lockwashers (26) (Items 15 & 16, WP 0061 00)

References

WP 0038 00

Tools and Special Tools

Drain Pan
 Floor Jack
 Jackstands (2)
 Tool Kit, General Mechanic's

Personnel

Two

Equipment Conditions

Hubs and Brakedrums Removed (WP 0039 00)
 Wheels Removed (WP 0020 00)

REMOVAL

WARNING

Axle (2) is heavy and awkward to handle. Use caution, provide adequate support, and use assistance during removal. Failure to follow this warning may result in serious injury.

NOTE

Generally, axle assemblies will not be removed unless inspection shows a need for repair or replacement. For inspection purposes, remove wheels (WP 0020 00) and hub and brakedrums (WP 0039 00).

1. Position trailer on level surface with front end resting on landing gear. Raise one side of trailer with stabilizer and place a jackstand on corner of rear crossmember. Lower and remove stabilizer. Repeat for other side.
2. Place a suitable floor jack under midpoint of axle (2).
3. Disconnect handbrake cable (3) from brake lever (1).

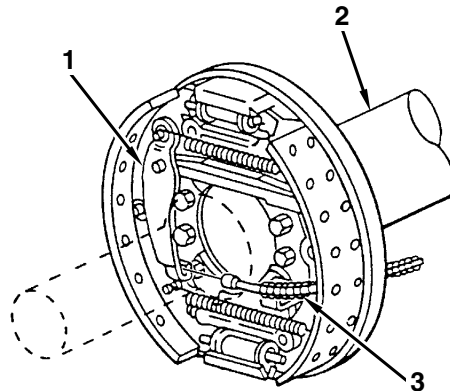

REMOVAL—Continued

4. Loosen two nuts (6) and remove handbrake cable (3) from guide bracket (5) on backing plate (10).

NOTE

A suitable container should be used to catch any draining brake fluid. Ensure that all spills are cleaned up.

5. Loosen nut (7) and disconnect tube (4) from connector (9).
6. Remove 12 nuts (11), lockwashers (12), screws (8), and backing plate (10) from axle (2). Discard lockwashers.
7. Repeat steps 3 through 6 on opposite end of axle (2).

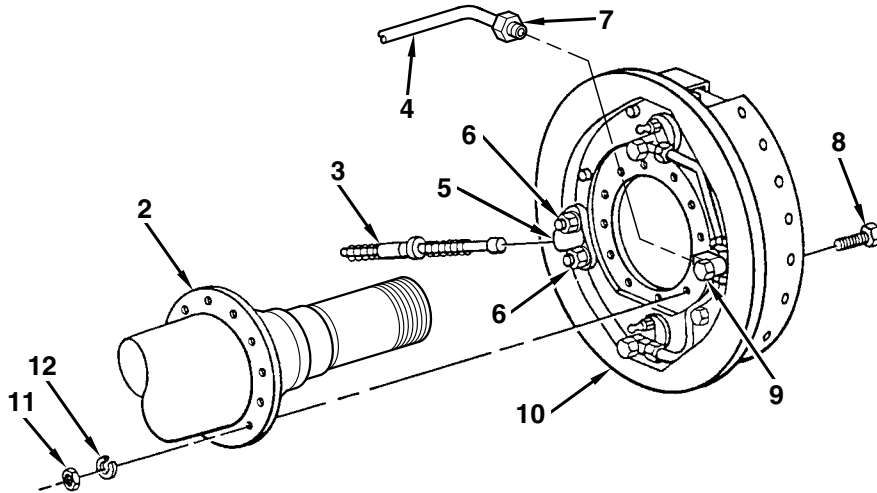

8. Remove nut (13), lockwasher (14), clamp (15), nut (18), lockwasher (17), connector (16), and two tubes (4) from axle (2). Discard lockwashers.

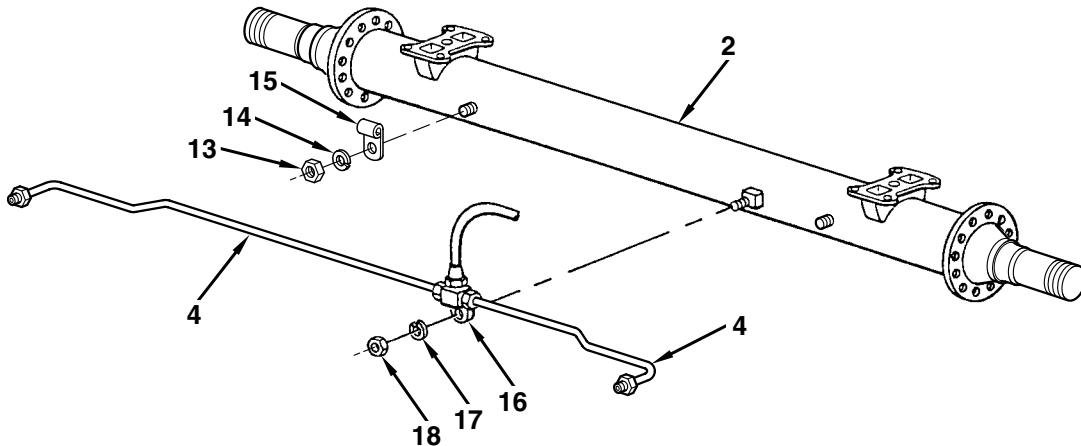

REMOVAL—Continued

9. Using floor jack, raise and support axle (2) at both ends. Remove eight locknuts (20), four U-bolts (22), and two plates (19) from axle and springs (21). Discard locknuts.
10. Carefully lower and remove axle (2) from springs (21).

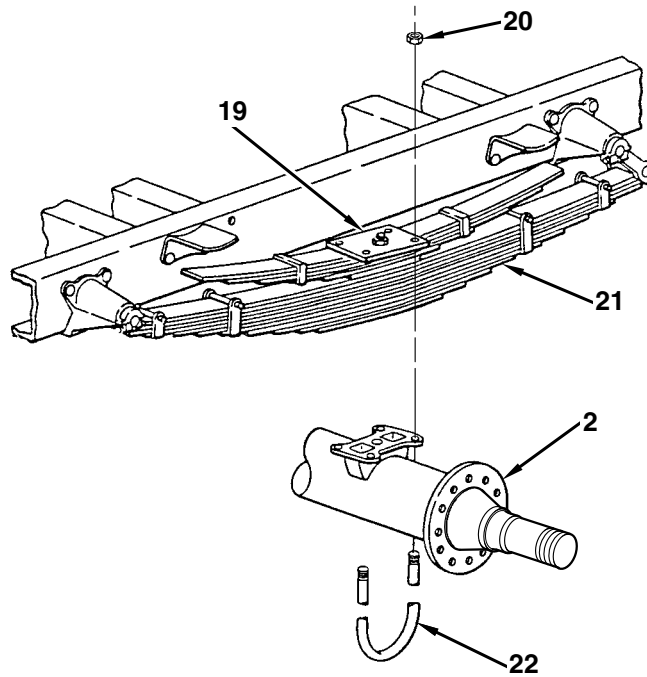

CLEANING

1. Remove dirt with water and brush.

WARNING

Solvents can burn easily, can give off harmful vapors, and are harmful to skin and clothing. To avoid injury or death, keep away from open fire and use in a well-ventilated area. If solvent gets on skin or clothing, wash immediately with soap and water.

2. Remove grease from axle and wheel retaining parts with cleaning solvent.

INSPECTION AND REPAIR

1. Check threads of axle spindle for wear, crossed threads, or other damage.
2. Using fine file, remove burrs, or hand chase threads if necessary.
3. Check axle spindle for bend. Indications of a bent axle spindle are binding bearings, which cannot be adjusted properly, and extremely uneven wear of brake linings. Replace axle if spindle is defective.
4. Check for damaged paint and repaint where necessary.

INSTALLATION

WARNING

Axle (2) is heavy and awkward to handle. Use caution, provide adequate support, and use assistance during installation. Failure to follow this warning may result in serious injury.

1. Position axle (2) on dolly.
2. Place support under axle (2).
3. Carefully raise and position axle (2) on springs (21). Support axle at both ends.
4. Install four U-bolts (22), two plates (19), and eight new locknuts (20) on axle (2) and springs (21).
5. Tighten nuts (20) to a torque of 223 lb-ft (302 N•m).

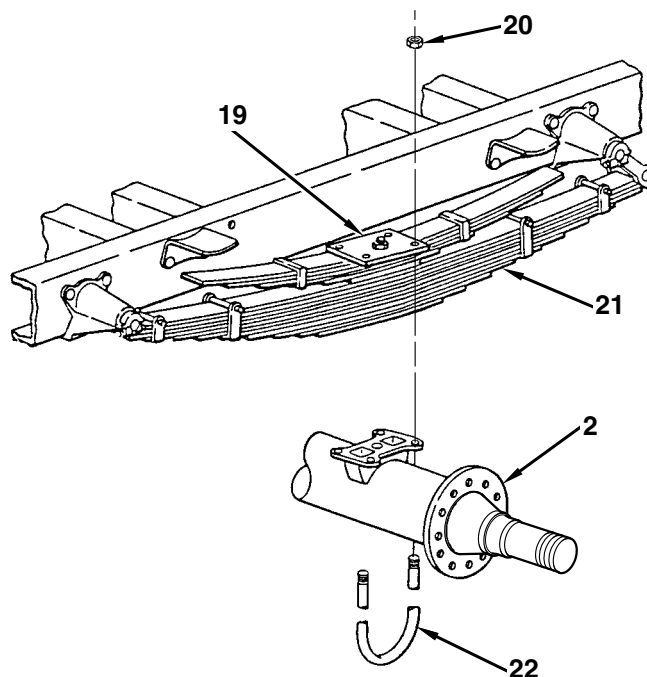

INSTALLATION—Continued

6. Install union tee (16) and two tubes (4) on axle (2) with new lockwasher (17), nut (18), clamp (15), new lockwasher (14), and nut (13).

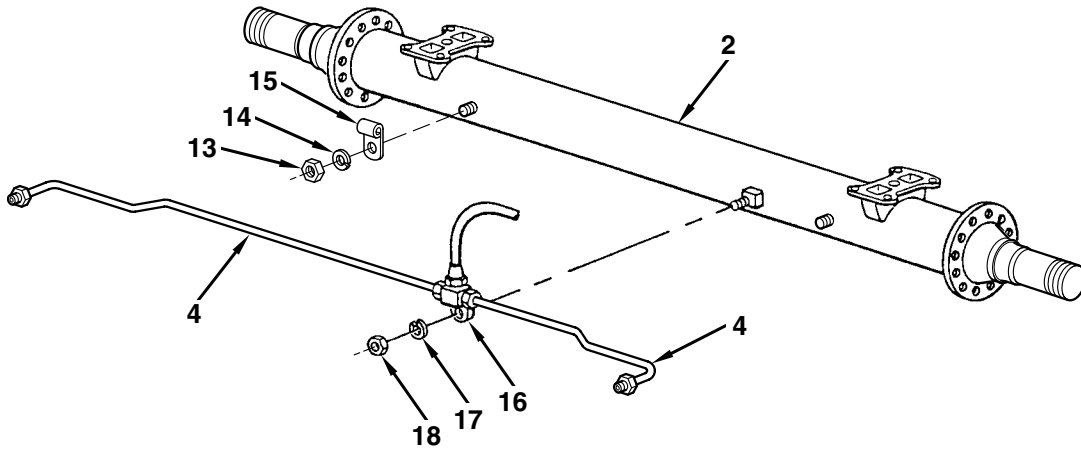

7. Install backing plate (10) on axle (2) with 12 screws (8), flatwashers (13), new lockwashers (12), and nuts (11).
8. Connect tube (4) to connector (9) and tighten nut (7).
9. Position handbrake cable (3) under guide bracket (5) and tighten two nuts (6).

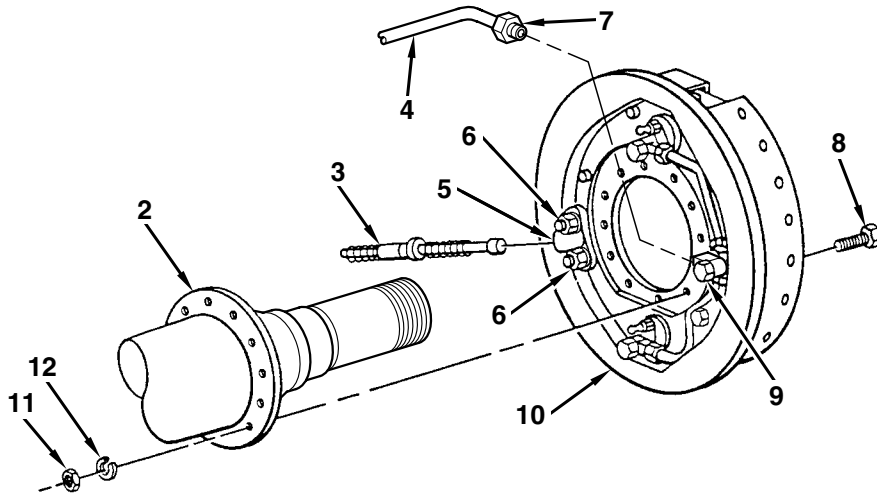

AXLE REPLACEMENT—Continued

0052 00

INSTALLATION—Continued

10. Connect handbrake cable (3) to brake lever (1).
11. Repeat steps 7 through 10 for opposite end of axle (2).
12. Lower and remove floor jack.

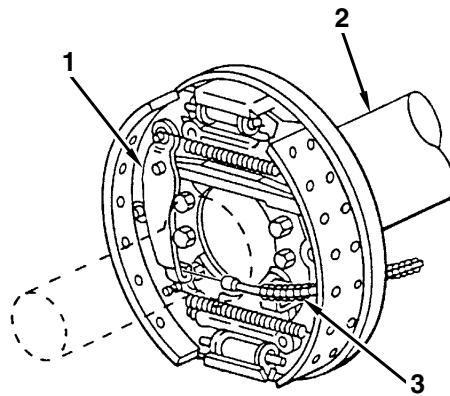

FOLLOW-ON TASKS

1. Install hubs and brakedrums (WP 0039 00).
2. Raise one side of trailer with stabilizer and remove jackstand. Lower and remove stabilizer. Repeat for other side.
3. Bleed brakes (WP 0038 00).

END OF TASK

BRAKEDRUM REPAIR

0053 00

THIS WP COVERS:

Inspection, Repair

INITIAL SETUP:

Maintenance Level

Direct Support and General Support

Tools and Special Tools

Brakedrum Lathe

Dial Indicator

Inside Micrometer

Tool Kit, General Mechanic's

Equipment Conditions

Hub and Brakedrum Removed (WP 0039 00)

INSPECTION

WARNING

Do not handle brakeshoes, brakedrums, or other brake components unless area has been properly cleaned. There may be hazardous dust on these components which can be dangerous if you touch it or breathe it. Wear an approved filter mask and gloves. Never use compressed air or a dry brush to clean brake components. Dust may be removed using an industrial-type vacuum cleaner. Clean dust or mud away from brake components with water and a wet, soft cloth. Failure to follow this warning may result in serious illness or death.

1. Inspect stud holes (2) for cracks (3). Discard brakedrum (1) if cracks are present.

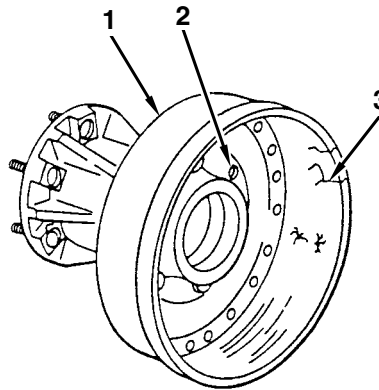

INSPECTION—Continued

WARNING

Do not use a brakedrum that exceeds maximum wear specifications. Failure to follow this warning may result in brake failure and serious injury or death.

2. Inspect braking surface (6) for cracks (3), heat checking (4), and scoring (5). Reface braking surface if damaged (see "REPAIR" below).
3. Inspect braking surface (6) or out-of-round at 45° intervals. Out-of-round should not exceed 0.006 in. (0.15 mm). If runout exceeds 0.006 in. (0.15 mm), reface braking surface (see "REPAIR" below).
4. Measure inside diameter of brakedrum (1). Discard brakedrum if inside diameter exceeds 15.23 in. (38.68 cm).

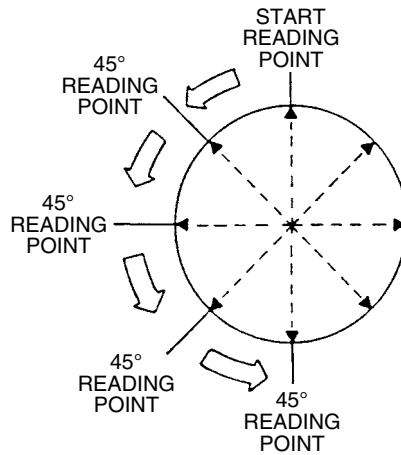
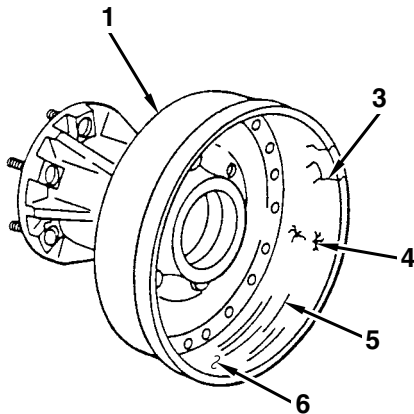

REPAIR

WARNING

Do not use a brakedrum that exceeds maximum wear specifications. Failure to follow this warning may result in brake failure and serious injury or death.

1. Reface braking surface (6) with brakedrum lathe, removing a maximum of 0.01 in. (0.25 mm) per cut.
2. Discard brakedrum (1) if inside diameter exceeds 15.23 in. (38.68 cm) after repair.

FOLLOW-ON TASK

Install hub and brakedrum (WP 0039 00).

END OF TASK

TIRE REPAIR

0054 00

Refer to TM 9-2610-200-24 for instructions on tire repair.

FRAME ASSEMBLY REPAIR

0055 00

1. Repair of frame assembly consists of welding, straightening, and reconditioning of damaged part or parts.
2. Repair frame assembly in accordance with TM 9-2300-247-40.

CARGO BODY MAINTENANCE

0056 00

THIS WP COVERS:

Removal, Repair, Installation

INITIAL SETUP:

Maintenance Level

Direct Support and General Support

Tools and Special Tools

Tool Kit, General Mechanic's

Materials/Parts

Lockwashers (12) (Item 14, WP 0061 00)

Personnel

Two

References

TM 43-0139

Equipment Conditions

Composite Lights Removed (WP 0026 00)
Reflectors Removed (WP 0049 00)
Running Lights Removed (WP 0027 00)
Spare Wheel Removed (WP 0020 00)
Tailgate Removed (WP 0046 00)

REMOVAL

WARNING

To remove cargo body, connect front and rear cargo tiedowns to a lifting device. While this operation is being performed, stand clear. Failure to follow this warning may result in serious injury or death.

REMOVAL—Continued

1. Remove 12 nuts (5), lockwashers (6), flatwashers (4), screws (3), and flatwashers (2). Discard lockwashers.
2. Using a suitable lifting device, remove cargo body (1) from frame assembly (7).

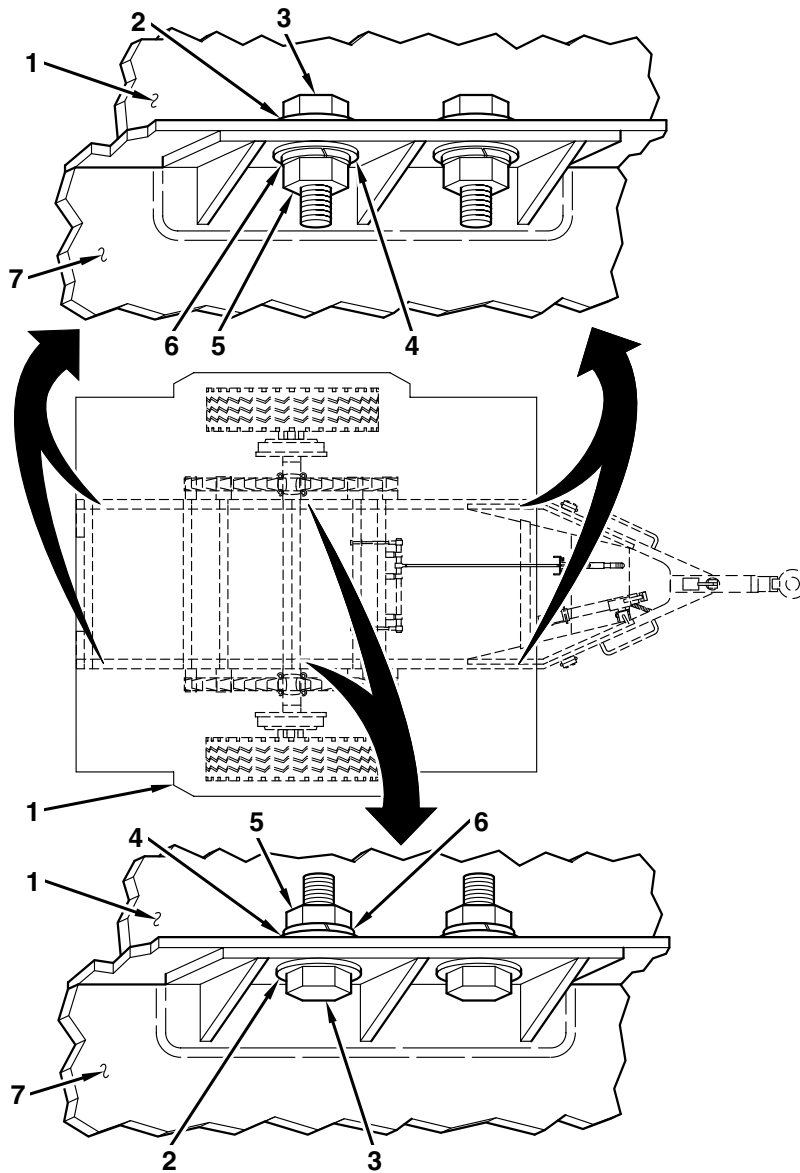

REMOVAL—Continued

3. Remove two bumpers (8) and washers (9).
4. Loosen two nuts (13) and remove two jounce tops (10), spacers (11), washers (12), and nuts.
5. Remove two grommets (14).
6. Remove lockpin (15) from bracket (16) and remove stabilizer (17).

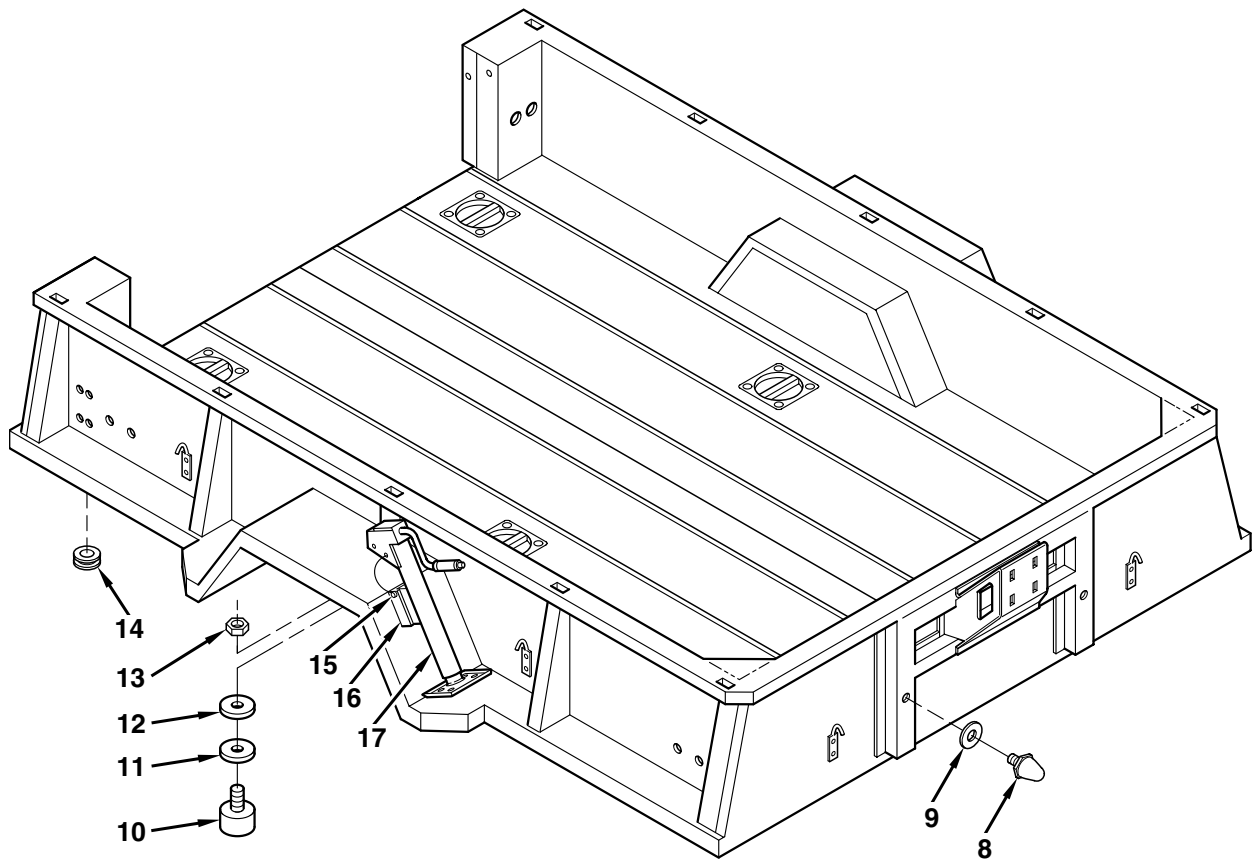

REPAIR

1. Repairs to cargo body consist of welding and restoring any damaged part or parts.
2. Cargo body repairs shall be in accordance with TM 43-0139.

INSTALLATION

1. Install stabilizer (17) by installing lockpin (15) to bracket (16).
2. Install two grommets (14).
3. Install two nuts (13), washers (12), spacers (11), jounce stops (10) and tighten two nuts.
4. Install two washers (9) and bumpers (8).

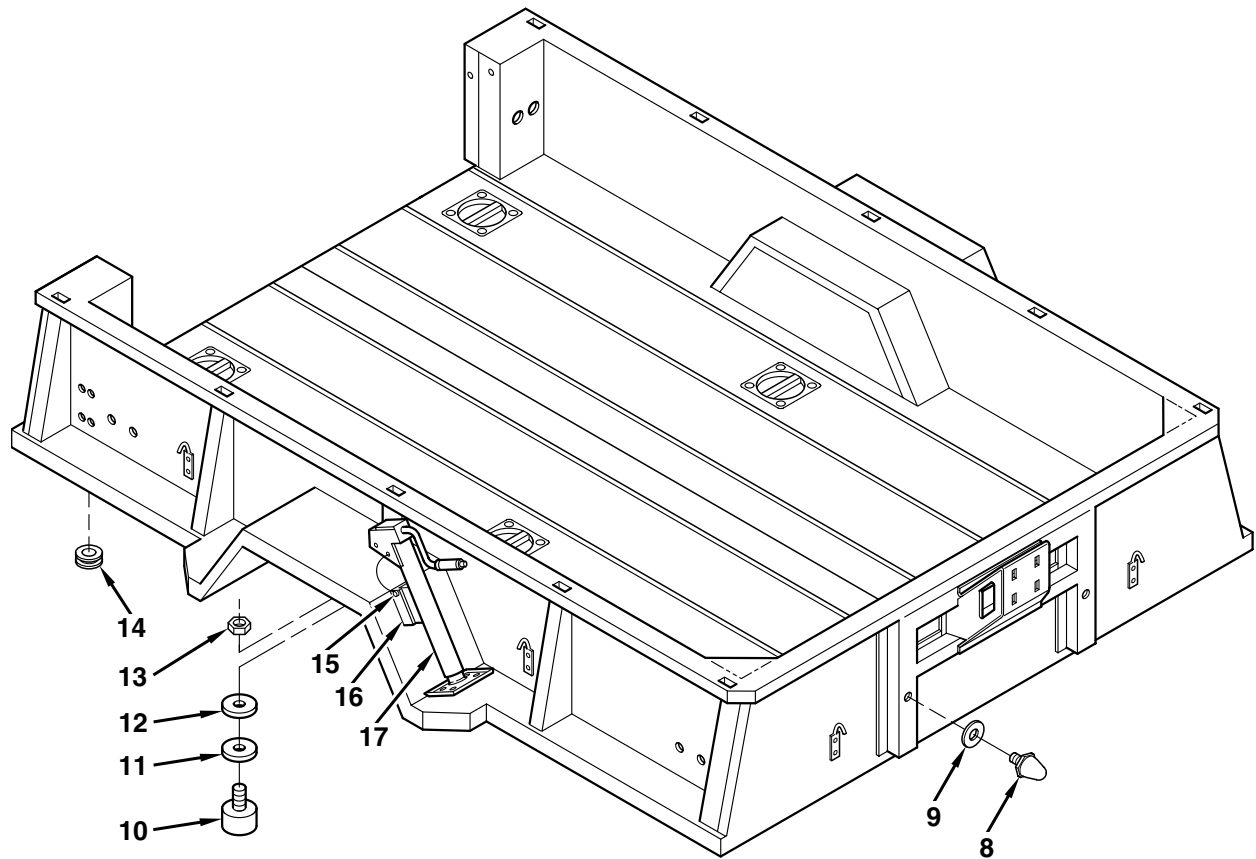

INSTALLATION—Continued

WARNING

To install cargo body, connect front and rear cargo tiedowns to a lifting device. While this operation is being performed, stand clear. Failure to follow this warning may result in serious injury or death.

5. Lift cargo body (1) into position on frame assembly (7).
6. Install 12 flatwashers (2), screws (3), flatwashers (4), new lockwashers (6), and nuts (5). Torque nuts to 159 lb-ft (216 N•m).

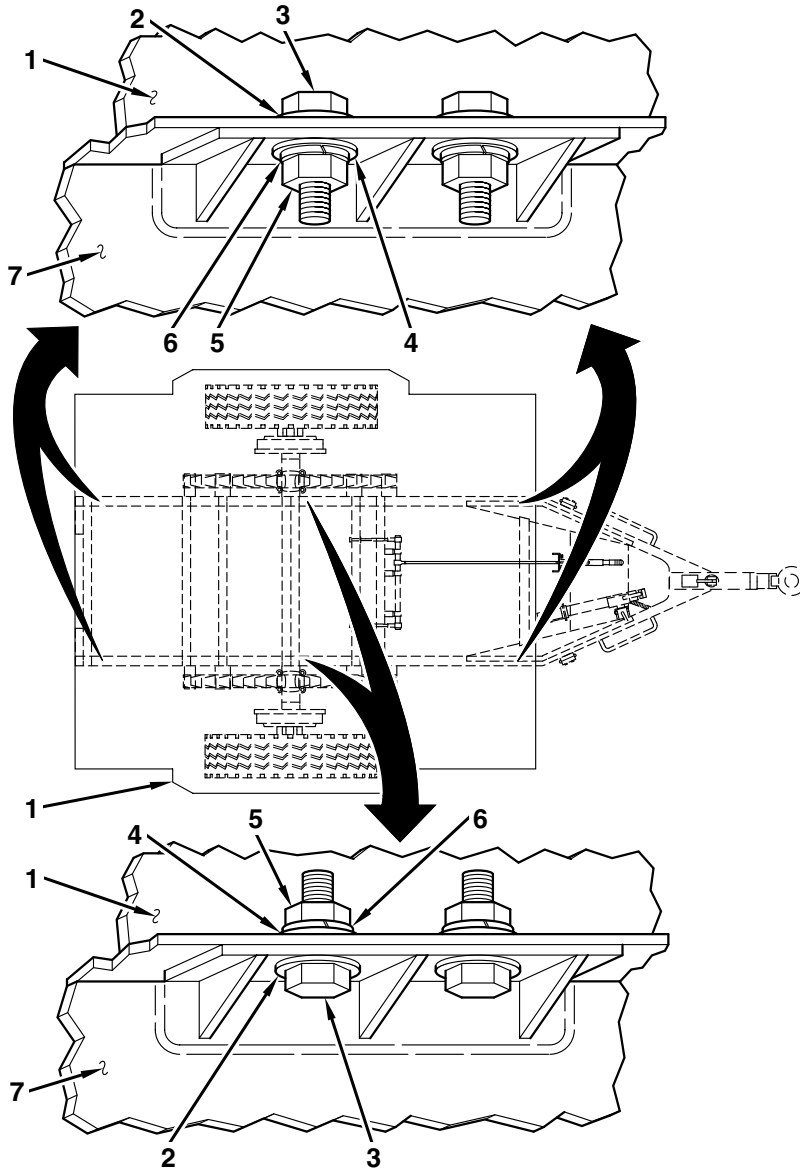

CARGO BODY MAINTENANCE—Continued

0056 00

FOLLOW-ON TASKS

1. Install tailgate (WP 0046 00).
2. Install spare wheel (WP 0020 00).
3. Install running lights (WP 0027 00).
4. Install reflectors (WP 0049 00).
5. Install composite lights (WP 0026 00).

END OF TASK

CHAPTER 8
SUPPORTING INFORMATION
FOR
M105A3 CARGO TRAILER

REFERENCES

0057 00

SCOPE

This WP lists the Army regulation, common tables of allowances, field manuals, forms, pamphlets, technical bulletins, and technical manuals referenced in this manual.

MILITARY PUBLICATION INDEX AND GENERAL REFERENCES

The following index and general references should be consulted frequently for the latest changes or revisions to references listed in this WP and for new publications relating to materiel covered in this publication.

Military Publication Index

Consolidated Index of Army Publications and Blank Forms DA PAM 25-30

ARMY REGULATION

Army Logistics Readiness and Sustainability AR 700-138

COMMON TABLES OF ALLOWANCES

Army Medical Department Expendable/Durable Items.....CTA 8-100
 Expendable/Durable Items (Except Medical, Class V, Repair Parts, and Heraldic
 Items).....CTA 50-970

FIELD MANUALS

Army Motor Transport Units and Operations..... FM 55-30
 Manual for the Wheeled Vehicle Driver.....FM 21-305
 Multiservice Helicopter Sling Load Single Point Load-Rigging Procedures.....FM 10-450-4
 Multiservice Helicopter Sling Load Dual Point Load-Rigging ProceduresFM 10-450-5
 Operation and Maintenance of Ordnance Materiel in Cold Weather (0° to -65°F)..... FM 9-207

FORMS

Equipment Inspection and Maintenance Worksheet DA Form 2404
 Equipment Log Assembly (Records) DA Form 2408
 Maintenance Request DA Form 2407
 Preventive Maintenance Schedule and Record.....DD Form 314
 Processing and Deprocessing Record for Shipment, Storage, and Issue of
 Vehicles and Spare Engines.....DD Form 1397
 Product Quality Deficiency Report..... SF 368

PAMPHLET

The Army Maintenance Management System (TAMMS)
 Users ManualDA PAM 750-8

TECHNICAL BULLETINS

Color, Marking, and Camouflage Painting of Military Vehicles, Construction
Equipment, and Materials Handling Equipment..... TB 43-0209
Tactical Wheeled Vehicles: Repair of Frames.....TB 9-2300-247-40

TECHNICAL MANUALS

Inspection, Care, and Maintenance of Antifriction Bearings..... TM 9-214
Materials Used for Cleaning, Preserving, Abrading, and Cementing Ordnance
Materiel and Related Materials Including Chemicals TM 9-247
Painting Instructions for Army Materiel.....TM 43-0139
Procedures for Destruction of Tank-Automotive Equipment to Prevent Enemy Use TM 750-244-6
Transportability Criteria and Guidance for Loading and Unloading Multilevel RailcarsTM 55-625
Railway Operating and Safety RulesTM 55-21

TM 9-2330-324-14&P
APPENDIX B
MAINTENANCE ALLOCATION CHART (MAC)
Section 1: INTRODUCTION

B-1. General

This introduction provides a general explanation of all maintenance and repair functions authorized at the two maintenance levels under the Two-Level Maintenance System concept.

The MAC (immediately following the introduction) designates overall authority and responsibility for the performance of maintenance functions on the identified end item or component. The application of the maintenance functions to the end item or component shall be consistent with the capacities and capabilities of the designated maintenance levels, which are shown on the MAC in column (4) as:

Field — includes two subcolumns, Unit (C (operator/crew) and O (unit) maintenance) and Direct Support (F) maintenance

Sustainment — includes two subcolumns, general support (H) and depot (D)

The tools and test equipment requirements (immediately following the MAC) list the tools and test equipment (both special tools and common tool sets) required for each maintenance function as referenced for the MAC).

The remarks (immediately following the tools and test equipment requirements) contain supplemental instructions and explanatory notes for a particular maintenance function.

B-2. Maintenance Functions

Maintenance functions are limited to and defined as follows:

1. Inspect. To determine the serviceability of an item by comparing its physical, mechanical, and/or electrical characteristics with established standards through examination (e.g.; by sight, sound, or feel). This includes scheduled inspection and gagings and evaluation of cannon tubes.
2. Test. To verify serviceability by measuring the mechanical, pneumatic, hydraulic, or electrical characteristics of an item and comparing those characteristics with prescribed standards on a scheduled basis, i.e., load testing of lift devices and hydrostatic testing of pressure hoses.
3. Service. Operations required periodically to keep an item in proper operating condition, e.g., to clean (includes decontaminate, when required), to preserve, to drain, to paint, or to replenish fuel, lubricants, chemical fluids, or gases. This includes scheduled exercising and purging or recoil mechanisms.
4. Adjust. To maintain or regulate, within prescribed limits, by bringing into proper position, or by setting the operating characteristics to specified parameters.
5. Align. To adjust specified variable elements of an item to bring about optimum or desired performance.
6. Calibrate. To determine and cause corrections to be made or be adjusted on instruments of test, measuring, and diagnostic equipment used in precision measurement. Consists of comparisons of two instruments, one of which is a certified standard of known accuracy, to detect and adjust any discrepancy in the accuracy of the instrument being compared.

TM 9-2330-324-14&P
APPENDIX B
MAINTENANCE ALLOCATION CHART (MAC)
Section 1: INTRODUCTION

7. Remove/Install. To remove and install the same item when required to perform service or other maintenance functions. Install may be the act of emplacing, seating, or fixing into position a spare, repair part, or module (component or assembly) in a manner to allow the proper functioning of an equipment or system.
8. Replace. To remove an unserviceable item and install a serviceable counterpart in its place. "Replace" is authorized by the MAC and assigned maintenance level is shown as the third position code of the Source, Maintenance, and Recoverability (SMR) code.
9. Repair. The application of maintenance services, including fault location/troubleshooting, removal/installation, disassembly/assembly procedures, and maintenance actions to identify troubles and restore serviceability to an item by correcting specific damage, fault, malfunction, or failure in a part, subassembly, module (component or assembly), end item, or system.

NOTE

The following definitions are applicable to the "repair" maintenance function services:
Inspect, test, service, adjust, align, calibrate, and/or replace.

- Fault location/troubleshooting. The process of investigating and detecting the cause of equipment malfunctioning; the act of isolating a fault within a system of Unit Under Test (UUT).
 - Disassembly/assembly. The step-by-step breakdown (taking apart) of a spare/functional group coded item to the level of its least component, that is assigned an SMR code of the level of maintenance under consideration (i.e., identified as maintenance significant).
 - Actions. Welding, grinding, riveting, straightening, facing, machining, and/or resurfacing.
10. Overhaul. That maintenance effort (service/action) prescribed to restore an item to a completely serviceable/operational condition as required by maintenance standards in appropriate technical publications. Overhaul is normally the highest degree of maintenance performed by the Army. Overhaul does not normally return an item to "like new" condition.
 11. Rebuild. Consists of those services/actions necessary for the restoration of unserviceable equipment to a "like new" condition in accordance with original manufacturing standards. Rebuild is the highest degree of material maintenance applied to Army equipment. The rebuild operation includes the act of returning to zero those age measurements (e.g., hours/miles) considered in classifying Army equipment/components.

Explanation of Columns in the MAC

Column (1) Group Number. Column (1) lists FGC numbers, the purpose of which is to identify maintenance significant components, assemblies, subassemblies, and modules with the Next Higher Assembly (NHA).

Column (2) Component/Assembly. Column (2) contains the item names of components, assemblies, subassemblies, and modules for which maintenance is authorized.

TM 9-2330-324-14&P
APPENDIX B
MAINTENANCE ALLOCATION CHART (MAC)
Section 1: INTRODUCTION

Column (3) Maintenance Function. Column (3) lists the functions to be performed on the item listed in column (2). (For a detailed explanation of these functions, refer to "Maintenance Functions" outlined above).

Column (4) Maintenance Level. Column (4) specifies each level of maintenance authorized to perform each function listed in column (3), by indicating work time required (expressed as man-hours in whole hours or decimals) in the appropriate subcolumn. This work time figure represents the active time required to perform that maintenance function at the indicated level of maintenance. If the number or complexity of the tasks within the listed maintenance function varies at different maintenance levels, appropriate work time figures are to be shown for each level. The work time figure represents the average time required to restore an item (assembly, subassembly, component, module end item, or system) to a serviceable condition under typical field operating conditions. This time includes preparation time (including any necessary disassembly/assembly time), troubleshooting/fault location time, and quality assurance time in addition to the time required to perform the specific tasks identified for the maintenance functions authorized in the MAC. The symbol designations for the various maintenance functions are as follows:

Field:

C Operator or crew maintenance
O Unit maintenance
F Direction support maintenance

Sustainment:

H General support maintenance
D Depot maintenance

NOTE

The "L" maintenance level is not included in column (4) of the MAC. Functions to this level of maintenance are identified by a work time figure in the "H" column of column (4), and an associated reference code is used in the REMARKS column (6). This code is keyed to the remarks and the SRA complete repair application is explained there.

Column (5) Tools and Equipment Reference Code. Column (5) specifies, by code, those common tool sets (not individual tools), common Test, Measurement and Diagnostic Equipment (TMDE), and special tools, special TMDE and special support equipment required to perform the designated function. Codes are keyed to the entries in the tools and test equipment table.

Column (6) Remarks Code. When applicable, this column contains a letter code, in alphabetical order, which is keyed to the remarks table entries.

Explanation of Columns in the Tools and Test Equipment Requirements

Column (1) Tool or Test Equipment Reference Code. The tool or test equipment reference code correlates with a code used in column (5) of the MAC.

Column (2) Maintenance Level. The lowest level of maintenance authorized to use the tool or test equipment.

Column (3) Nomenclature. Name or identification of the tool or test equipment.

Column (4) National Stock Number (NSN). The NSN of the tool or test equipment.

TM 9-2330-324-14&P
APPENDIX B
MAINTENANCE ALLOCATION CHART (MAC)
Section 1: INTRODUCTION

Column (5) Tool Number. The manufacturer's part number, model number, or type number.

Explanation of Columns in the Remarks

Column (1) Remarks Code. The code recorded in column (6) of the MAC.

Column (2) Remarks. This column lists information pertinent to the maintenance function being performed as indicated in the MAC.

Table 1. MAC for CHASSIS, TRAILER: GENERATOR, 2 1/2-TON, 2-WHEEL, M200A1

(1) GROUP NUMBER	(2) COMPONENT/ ASSEMBLY	(3) MAINTENANCE FUNCTION	(4) MAINTENANCE LEVEL					(5) TOOLS AND EQPT	(6) REMARKS
			FIELD		SUSTAINMENT				
			UNIT	DS	GS	DEPOT			
			C	O	F	H	D		

Table 2. Tools and Test Equipment for CHASSIS, TRAILER: GENERATOR, 2 1/2-TON, 2-WHEEL, M200A1

(1) TOOLS OR TEST EQUIPMENT	(2) MAINTENANCE LEVEL	(3) NOMENCLATURE	(5) NATIONAL STOCK NUMBER	(6) TOOL NUMBER

Table 3. Remarks for CHASSIS, TRAILER: GENERATOR, 2 1/2-TON, 2-WHEEL, M200A1

REMARK CODES	REMARKS

SECTION II. MAINTENANCE ALLOCATION CHART—Continued. M105A3 Cargo Trailer

(1) GROUP NUMBER	(2) COMPONENT/ ASSEMBLY	(3) MAINTENANCE FUNCTION	(4)					(5) TOOLS AND EQUIPMENT	(6) REMARKS		
			FIELD		SUSTAINMENT						
			UNIT		DS	GS	DEPOT				
C	O	F	H	D							
06 0609	ELECTRICAL SYSTEM <i>Lights</i>	Composite Light		0.2					1		
		Repair		0.2					1, 2, 3	A	
	Running Light	Replace		0.2					1		
		Repair		0.2					1, 2, 3	A	
	0613	Chassis Wiring Harness	Replace		0.5					1	
			Repair		0.5					1, 2, 3, 9, 18, 19	B
		Intervehicular Cable Assembly	Replace		0.2					1	
			Repair		0.2					1, 2, 3, 9, 18, 19	B
	11 1100	REAR AXLE <i>Rear Axle Assembly</i>	Replace						5.0	1, 2, 13, 17, 20	
	12 1201	BRAKES <i>Handbrake</i>									
Handbrake Lever	Adjust	0.2									
	Replace		1.0						1		
Handbrake Linkage and Cables	Adjust		0.5						1		
	Replace		1.5						1, 20		
1202	<i>Service Brakes</i>	Adjust		0.2					1		
Brakeshoes	Replace		1.5						1, 2, 7, 20		
1204	<i>Hydraulic Brake System</i>	Bleed		0.5					1, 2		
Brake Actuator	Replace		1.0						1, 2, 17		
Breakaway Lever	Reset		0.5						1		
Wheel Cylinders	Replace		1.5						1, 2, 7, 17		
Brake Lines and Fittings	Replace		1.5						1, 2, 16, 17		

SECTION II. MAINTENANCE ALLOCATION CHART—Continued. M105A3 Cargo Trailer

(1) GROUP NUMBER	(2) COMPONENT/ ASSEMBLY	(3) MAINTENANCE FUNCTION	(4)					(5) TOOLS AND EQUIPMENT	(6) REMARKS
			FIELD		SUSTAINMENT				
			UNIT		DS	GS	DEPOT		
C	O	F	H	D					
13 1311	WHEELS <i>WHEEL ASSEMBLY</i>	Brakedrum	Replace	1.0				1, 2, 7	C
			Repair		1.5			1, 4, 8, 12, 14, 20	
		Wheel Hub	Replace	1.5				1, 2, 7, 18, 20	
		Wheel Bearings	Service	1.5				1, 2	
			Adjust	0.5				1, 2, 7	
			Replace	1.5				1, 2, 7, 18, 20	
		Oil Seal	Replace	1.0					
1313 <i>Tires and Tubes</i>	Tires	Replace	0.5					D	
		Repair		2.0			1, 2		
		Repair			2.0		1, 2		
15 1501	FRAME, TOWING ATTACHMENTS, AND DRAWBAR <i>Frame Assembly</i>				4.0			1, 2, 4, 5, 6	E, F
		1503 <i>Pintles and Towing Attachments</i>	Drawbar Coupler	Adjust	0.2				
Replace	0.5						1		
Safety Chain	Replace		0.5				1		
D-Ring	Replace		0.5				1		
1507 <i>Landing Gear, Leveling Jacks</i>	Landing Gear		Replace	1.0				1, 2, 13, 20	

SECTION II. MAINTENANCE ALLOCATION CHART—Continued. M105A3 Cargo Trailer

(1) GROUP NUMBER	(2) COMPONENT/ ASSEMBLY	(3) MAINTENANCE FUNCTION	(4)					(5) TOOLS AND EQUIPMENT	(6) REMARKS
			FIELD		SUSTAINMENT				
			UNIT		DS	GS	DEPOT		
C	O	F	H	D					
16 <i>1601</i>	SPRINGS AND SHOCK ABSORBERS <i>Springs</i>								
	Main Spring	Replace		2.5					1, 2, 13, 20
	Auxiliary Spring	Replace		1.0					1, 2, 13, 20
18 <i>1802</i>	BODY <i>Fenders</i>	Repair		1.5					1, 2, 4, 5, 6 F, G
<i>1810</i>	<i>Cargo Body</i>	Replace			1.5				1
		Repair			1.5				1, 2, 4, 5, 6 F, G
	Cargo Tiedown	Replace		0.5					1
	Tailgate	Replace		0.5					1
	Spare Wheel Rack	Replace		0.5					1
		Adjust		0.2					1
22 <i>2201</i>	ACCESSORY ITEMS <i>Canvas</i>	Replace		0.2					1
<i>2202</i>	<i>Accessory Items</i>								
	Reflector	Replace		0.2					1
<i>2210</i>	<i>Data Plates</i>	Replace		0.2					1

SECTION III. TOOLS AND TEST EQUIPMENT REQUIREMENT

(1)	(2)	(3)	(4)	(5)	
REFERENCE CODE	MAINTENACE CATEGORY	NOMENCLATURE	NATIONAL STOCK NUMBER	TOOL NUMBER	
1	O	Tool Kit, General Mechanic's: Automotive	5180-00-177-7033	SC 5180-90-N26	
2	O	Shop Equipment, Automotive Maintenance and Repair: Organizational Maintenance, Common No. 1, Less Power	4910-00-754-0654	SC 4910-95-A74	
3	O	Shop Equipment, Automotive Maintenance and Repair: Organizational Maintenance, Supplemental No. 1	4910-00-754-0653	SC 4910-95-A73	
4	F	Shop Equipment, Automotive Maintenance and Repair: Field Maintenance, Supplemental Set No. 2, Less Power	4910-00-754-0707	SC 4910-95-A63	
5	F	Tool Kit, Welder's	5180-00-754-0661	SC 5180-90-N39	
6	F	Shop Equipment, Welding, S/E Welding, Field Maintenance	3470-00-357-7268	SC 3470-95-A08	
7	O	Socket, Socket Wrench, 3/4-in. – Drive (Wheel Bearings)	5120-01-105-8593		
8	O	Caliper, Micrometer, Inside	5210-00-221-1921	SC 4910-95-A63	
9	O	Etcher, Electric	5130-00-596-8404	SC 4910-95-A74	
10	O	Gage, Depth, Tire Tread	5210-00-019-3050	SC 4910-95-A74	
11	O	Gage, Tire Pressure	5210-01-430-5212	CTA 50-970	
12	O	Indicator, Dial	5210-00-277-8840	SC 4910-95-A63	
13	O	Jack, Hydraulic, Hand, Self-Contained, 12-Ton Capacity	5120-00-224-7330	SC 4910-95-A74	
14	F	Lathe, Brake Drum	4910-01-028-9849	4100	
15	O	Multimeter, Digital	6625-01-139-2512	CTA 50-970	
16	O	Pail, Utility	7240-00-160-0455	CTA 50-970	
17	O	Pan, Drain, 4-Gallon Capacity, With Handles	4910-00-387-9592	17942	
18	O	Terminal Kit	5940-00-450-5802	SC 4910-95-A74	

SECTION III. TOOLS AND TEST EQUIPMENT REQUIREMENT

(1)	(2)	(3)	(4)	(5)	
REFERENCE CODE	MAINTENANCE CATEGORY	NOMENCLATURE	NATIONAL STOCK NUMBER	TOOL NUMBER	
19	O	Tool Kit, Electrical Connector Repair	5180-00-876-9336	CTA 50-970	
20	O	Trestle, Motor vehicle Maintenance (Jack Stands)	4910-00-251-8013	SC 4910-95-A74	

Section IV. REMARKS

REFERENCE CODE	REMARKS
A	Composite light repair is limited to door, preformed packing, and lamp/LED replacement.
B	Chassis wiring harness and intervehicular cable assembly repair is limited to terminal, lug, insulator, shell, and hardware replacement.
C	Brakedrum repair is limited to refacing braking surface using a brakedrum lathe.
D	Refer to TM 9-2610-200-24 for tire repair.
E	Refer for TB 9-2300-247-40 for frame assembly repair.
F	Frame assembly, fender, and cargo body repair consists of welding, straightening, and reconditioning of damaged part or parts.
G	Refer to TM 43-0139 for fender and cargo body repair.

INTRODUCTION

General

This WP lists additional items you are authorized for the support of the M105A3 Trailer.

Explanation of Columns in the AAL

Column (1)—Illus Number. Gives you the number of the item illustrated.

Column (2)—Part Number. Identifies the part number of the item to be used for requisitioning purposes.

Column (3)—Nomenclature. Identifies the Federal item name (in all capital letters). The stowage location of AAL is also included in this column.

Column (4)—Unit of Measure (U/M). Indicates the measure used in performing the actual operation/maintenance function. This measure is expressed by a two-character alphabetical abbreviation.

Column (5)—Qty Req. Indicates the quantity of the item authorized to be used with/on the equipment.

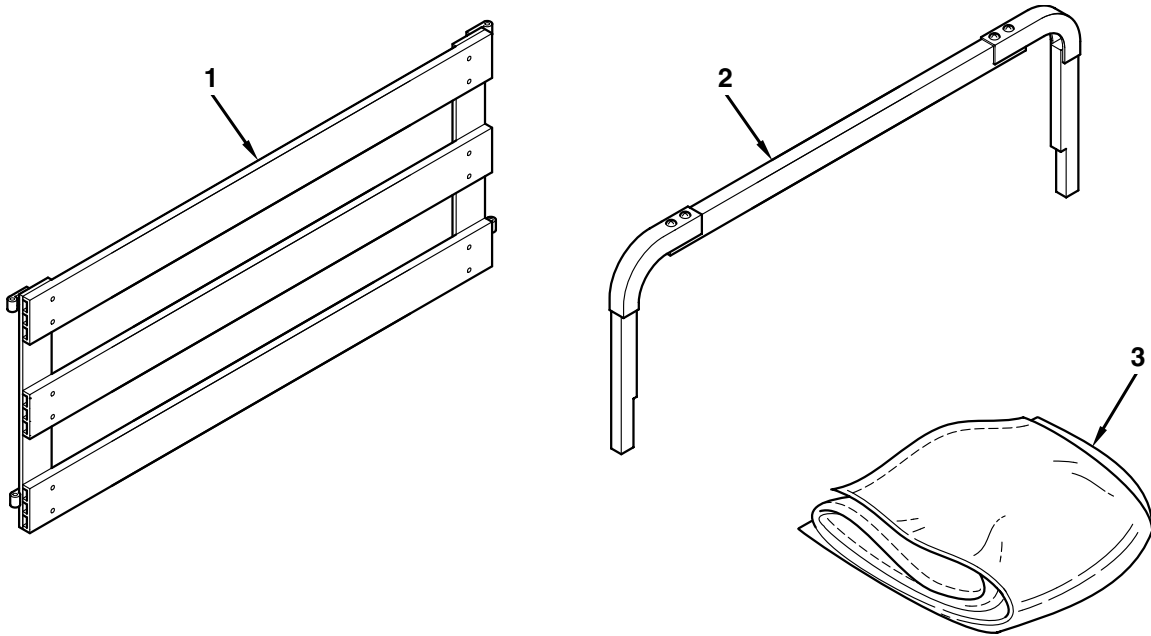

Table 1. AAL.

(1) ILLUS NUMBER	(2) PART NUMBER	(3) NOMENCLATURE	(4) U/M	(5) QTY REQ
1	1059020	FRONT STAKE RACK (in interior of cargo body)	EA	1
2	1059130	ROOF BOW (in interior of cargo body)	EA	5
3	1059180	TARPAULIN (in interior of cargo body)	EA	1

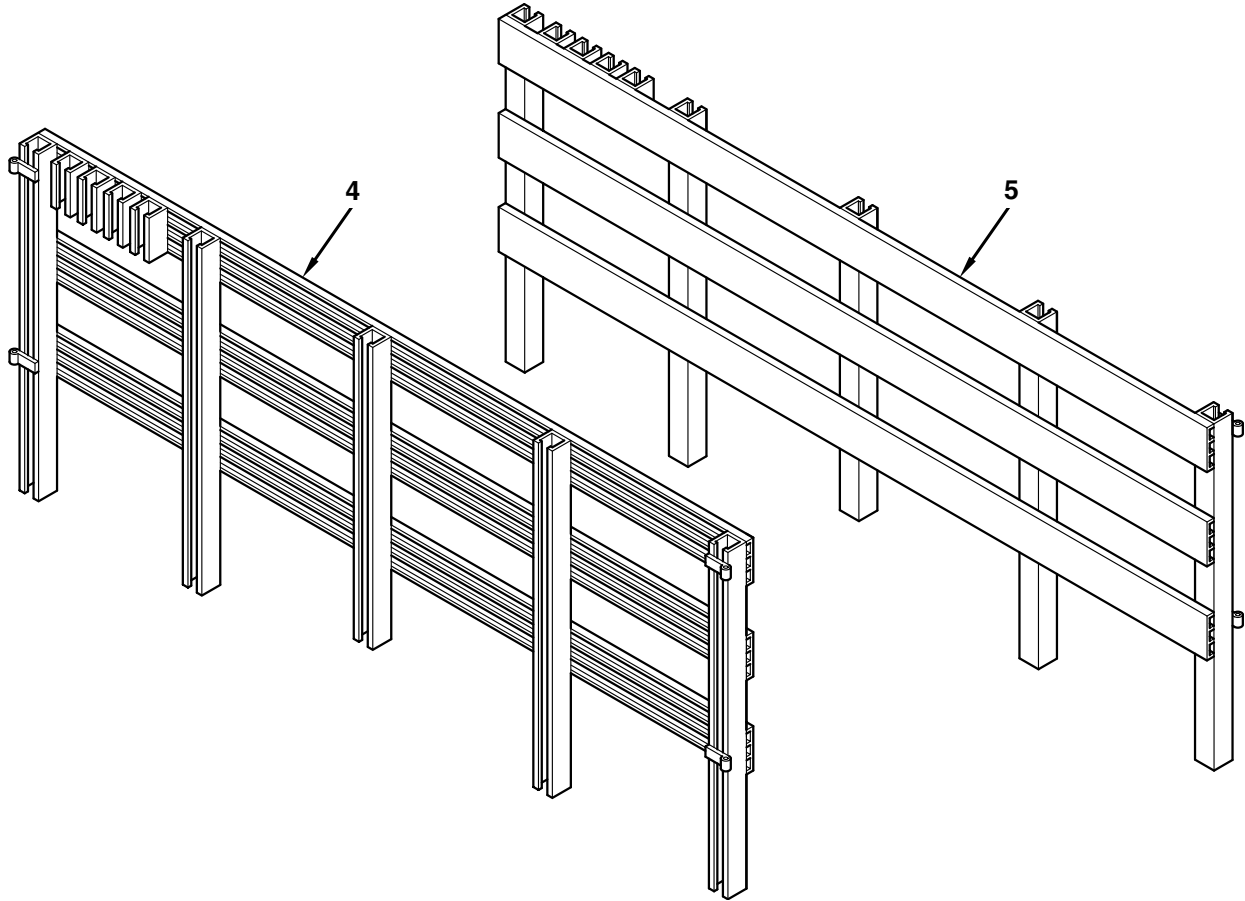
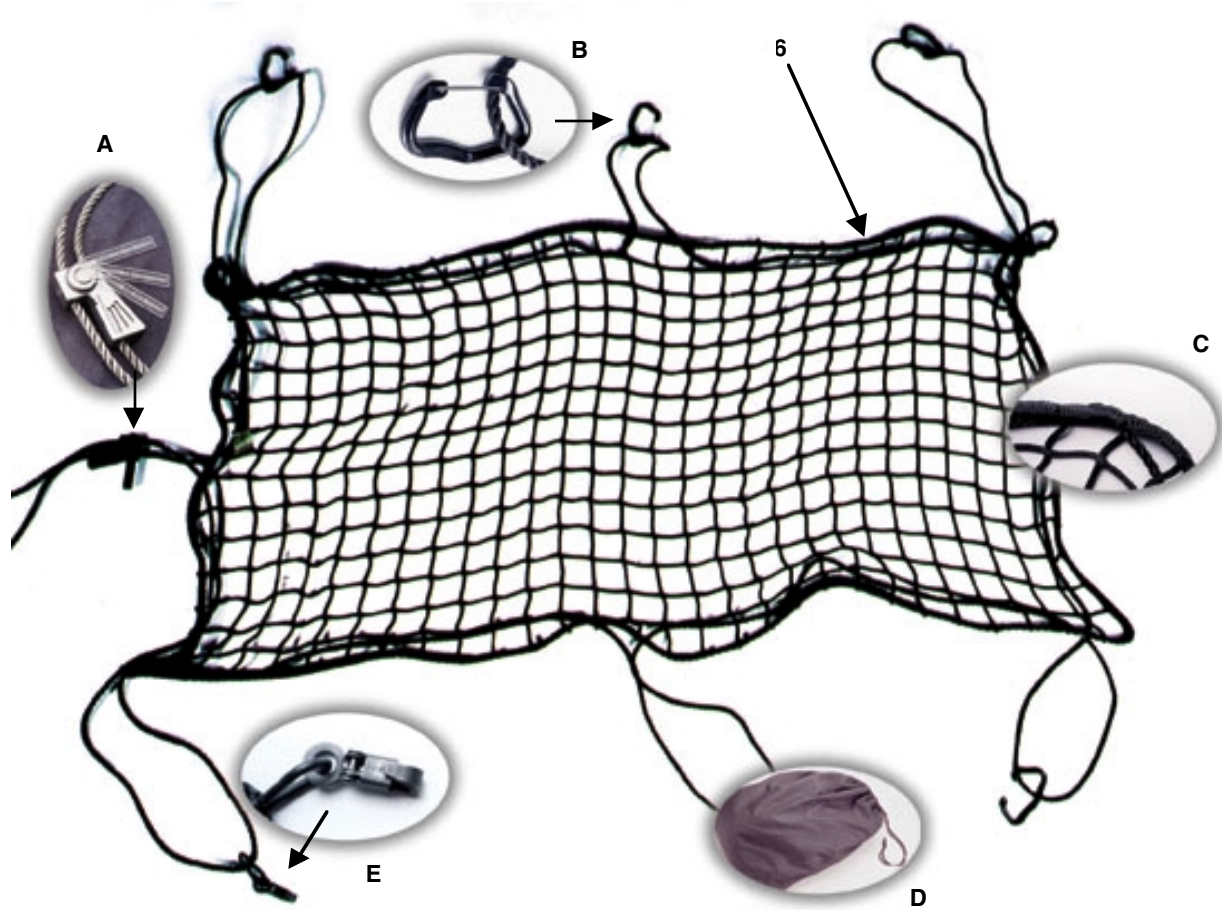

Table 1. AAL—Continued.

(1) ILLUS NUMBER	(2) PART NUMBER	(3) NOMENCLATURE	(4) U/M	(5) QTY REQ
4	1059010-1	LEFT SIDE STAKE RACK (in interior of cargo body)	EA	1
5	1059010-2	RIGHT SIDE STAKE RACK (in interior of cargo body)	EA	1



—KEY—

- A: Cinch lock slides up to right at 90° to open for tightening or letting out more cinch rope.
- B: Aluminum carabiners can attach to numerous points of the trailer.
- C: Cinch rope affixed to rope border to indicate the centerpoint and prevent accidental removal of the cinch rope. Cinch rope can be pulled out at numerous points to adjust to various load shapes and heights, and then pulled taut to tighten load.
- D: Black nylon stow bag allows for stowage when cargo net is not in use.
- E: Safety snap hooks and locking "J" snap hooks can attach to the trailer's "D" rings.

Table 1. AAL—Continued.

(1) ILLUS NUMBER	(2) PART NUMBER	(3) NOMENCLATURE	(4) U/M	(5) QTY REQ
6	B9154-078-114-2R	CARGO NET (in interior of cargo body)	EA	1

EXPENDABLE AND DURABLE ITEMS LIST

0060 00

INTRODUCTION**Scope**

This WP lists expendable and durable items that you will need to operate and maintain the M105A3 Trailer. This list is for informational purposes only and is not authority to requisition the listed items. These items are authorized to you by CTA 50-970, Expendable/Durable Items (Except Medical, Class V, Repair Parts, and Heraldic Items), or CTA 8-100, Army Medical Department Expendable/Durable Items.

Explanation of Columns in Table 1. Expendable and Durable Items List

Column (1)—Item Number. This number is assigned to the entry in the list and is referenced in the narrative instructions to identify the item (e.g., Use brake fluid (Item 4, WP 0060 00).

Column (2)—Level. This column identifies the lowest level of maintenance that requires the listed item:

C = Operator/Crew

O = Organizational

Column (3)—National Stock Number (NSN). This is the NSN assigned to the item which you can use to requisition it.

Column (4)—Item Name, Description, Commercial and Government Entity Code (CAGEC), and Part Number (P/N). This column provides the other information you need to identify the item.

Column (5)—Unit of Measure (U/M). This code shows the physical measurement or count of an item, such as gallon, dozen, gross, etc.

Table 1. Expendable and Durable Items List.

(1) ITEM NUMBER	(2) LEVEL	(3) NSN	(4) ITEM NAME, DESCRIPTION, CAGEC, PART NUMBER	(5) U/M
1	O	7920-00-061-0038	BRUSH, SCRUB	EA
2	O	5350-00-221-0872	CLOTH, ABRASIVE	EA
3	O	6850-01-435-6476	COMPOUND, CLEANING AND LUBRICATING	EA
4	O		FLUID, BRAKE, AUTOMOTIVE MIL-B-46176	
		9150-01-102-9455	1-Gallon Can	GL
		9150-01-123-3152	5-Gallon Can	GL
		9150-01-072-8379	55-Gallon Drum	GL
5	O		GREASE, AUTOMOTIVE AND ARTILLERY MIL-G-10924	
		9150-01-197-7688	2-1/4-Ounce Tube	OZ
		9150-01-197-7690	1.75-Pound can	LB
		9150-01-197-7689	6.5-Pound Can	LB
		9150-01-197-7692	35-Pound Can	LB
6	O	9905-00-537-8954	MARKER TAG	EA
7	C		OIL, LUBRICATING, INTERNAL COMBUSTION ENGINE, TACTICAL SERVICE MIL-L-2104	
		9150-01-178-4726	1-Quart Can	QT
		9150-00-188-9858	5-Gallon Can	GL
		9150-00-189-6729	55-Gallon Drum	GL
8	C		OIL, LUBRICATING, INTERNAL COMBUSTION ENGINE, ARCTIC MIL-L-46167	
		9150-00-402-4478	1-Quart Can	QT
		9150-00-401-2372	5-Gallon Can	GL
		9150-00-491-7197	55-Gallon Drum	GL
9	C	7920-00-205-1711	RAG, WIPING	LB
10	C	7930-01-328-2030	SOLVENT, CLEANING COMPOUND, DETERGENT, PF05	GL
11	O	9330-01-038-3486	TUBING, PLASTIC, 1/2-IN. DIAMETER	FT

MANDATORY REPLACEMENT PARTS LIST

0061 00

GENERAL

This WP lists all mandatory replacement parts referenced in the initial setups and procedures. These are items that must be replaced during maintenance whether they have failed or not.

Explanation of Columns in Table 1. Mandatory Replacement Parts List

Column (1)—Item Number. This number is assigned to the entry in the list and is referenced in the narrative instructions to identify the item.

Column (2)—Part Number. This column identifies the part number of the item.

Column (3)—National Stock Number (NSN). This is the NSN assigned to the item which you can use to requisition it.

Column (4)—Nomenclature This column provides the item name.

Column (5)—Quantity (QTY). This is the total quantity of the item.

MANDATORY REPLACEMENT PARTS LIST—Continued

0061 00

Table 1. Mandatory Replacement Parts List.

(1) ITEM NUMBER	(2) PARTNUMBER	(3) NSN	(4) NOMENCLATURE	(5) QTY.
1	A-A-52463-B10	6240-00-447-3779	LAMP	2
2	A52463-1-09	6240-00-019-3093	LAMP	2
3	MS20604S4T5		RIVET	8
4	MS24665-285	5315-01-359-1451	COTTER PIN	5
5	MS24665-423	5315-00-013-7228	COTTER PIN	8
6	MS24665-436	5315-00-236-8368	COTTER PIN	4
7	MS35335-32	5310-00-596-7691	LOCKWASHER	5
8	MS35335-35	5310-00-627-6128	LOCKWASHER	24
9	MS35335-37	5310-00-209-5116	LOCKWASHER	8
10	MS35338-24	5310-00-043-2226	LOCKWASHER	15
11	MS35338-25	5310-00-012-1637	LOCKWASHER	1
12	MS35338-26	5310-00-012-0214	LOCKWASHER	4
13	MS35338-27	5310-00-543-2705	LOCKWASHER	2
14	MS35338-30	5310-00-012-0898	LOCKWASHER	12
15	MS35338-43	5310-00-045-3296	LOCKWASHER	23
16	MS35338-44	5310-00-582-5965	LOCKWASHER	51
17	MS35338-45	5310-00-407-9566	LOCKWASHER	47
18	MS35338-46	5310-00-637-9541	LOCKWASHER	8
19	MS51922-17	5310-00-087-4652	LOCKNUT	36
20	MS51922-61	5310-00-832-9719	LOCKNUT	8
21	MS51943-31	5310-00-061-4650	LOCKNUT	3
22	M45913/1-4CG5C	5310-00-088-1251	LOCKNUT	5
23	M45913/1-8CBB	5310-00-008-7843	LOCKNUT	2

MANDATORY REPLACEMENT PARTS LIST—Continued

0061 00

Table 1. Mandatory Replacement Parts List—Continued.

(1) ITEM NUMBER	(2) PARTNUMBER	(3) NSN	(4) NOMENCLATURE	(5) QTY.
24	M45913/1-8CG5C	5310-00-225-6993	LOCKNUT	16
25	M45913/2-12FG5C	5310-00-832-9719	LOCKNUT	8
26	1052000		LANDING GEAR	1
27	1054100		BRAKE ACTUATOR	1
28	1054400		BREAKAWAY LEVER ASSEMBLY	2
29	1054430-1		BREAKAWAY LOCK—RIGHT	2
30	1054430-2		BREAKAWAY LOCK—LEFT	2
31	1054440		GASKET	2
32	10910885	5330-00-246-8223	GASKET	2
33	12360850-1	6220-01-284-2709	LED	2
34	12360870-2	6220-01-297-3217	LED	2
35	1251	6240-00-019-0877	LAMP	5
36	7411429	5330-00-741-1429	OIL SEAL	2

SCOPE

The RPSTL lists and authorizes spares and repair parts; special tools; special test, measurement, and diagnostic equipment (TMDE); and other special support equipment required for performance of organizational, direct support and general support maintenance of the M105A3 1-1/2 ton 2-wheel cargo trailer. It authorizes the requisitioning, issue, and disposition of spares, repair parts, and special tools as indicated by the source, maintenance, and recoverability (SMR) codes.

GENERAL

In addition to the Introduction work package, this RPSTL is divided into the following work packages.

1. Repair Parts List Work Packages. Work packages containing lists of spares and repair parts authorized by this RPSTL for use in the performance of maintenance. These work packages also include parts which must be removed for replacement of the authorized parts. Parts lists are composed of functional groups in ascending alphanumeric sequence, with parts in each group listed in ascending figure and item number sequence. Sending units, brackets, filters, and bolts are listed with the component they mount on. Bulk materials are listed by item name in FIG. BULK at the end of the work packages. Repair parts kits are listed separately in their own functional group and work package. Repair parts for reparable special tools are also listed in a separate work package. Items listed are shown on the associated illustrations.
2. Special Tools List Work Packages. Work packages containing lists of special tools, special TMDE, and special support equipment authorized by this RPSTL (as indicated by Basis of Issue (BOI) information in the DESCRIPTION AND USABLE ON CODE (UOC) column). Tools that are components of common tool sets and/or Class VII are not listed.
3. Cross-Reference Indexes Work Packages. There are two cross-reference indexes work packages in this RPSTL; the National Stock Number (NSN) Index work package and the Part Number (P/N) work package. The National Stock Number Index work package refers you to the figure and item number. The Part Number Index work package refers you to the figure and item number.

EXPLANATION OF COLUMNS IN THE REPAIR PARTS LISTS AND SPECIAL TOOLS LIST WORK PACKAGES.

ITEM NO. (Column (1)). Indicates the number used to identify items called out in the illustration.

SMR CODE (Column (2)). The SMR code containing supply/requisitioning information, maintenance level authorization criteria, and disposition instruction, as shown in the following breakout:

Source Code	Maintenance Code	Recoverability Code
xx	xx	x
1 st two positions: How to get an item.	3 rd position: Who can Install, replace, or use item.	4 th position: Who can complete repair* on the item.
		5 th position: Who determines disposition action on unserviceable items.

*Complete repair: Maintenance capacity, capability, and authority to perform all corrective maintenance tasks of the "Repair" function in a use/user environment in order to restore serviceability to a failed item.

Source Code. The source code tells you how you get an item needed for maintenance, repair, or overhaul of an end item/equipment. Explanations of source codes follow:

Source Code

Application/Explanation

PA
PB
PC
PD
PE
PF
PG

Stock items; use the applicable NSN to requisition/request items with these source codes. They are authorized to the level indicated by the code entered in the 3rd position of the SMR code.

NOTE

Items coded PC are subject to deterioration.

KD
KF
KB

Items with these codes are not to be requested/requisitioned individually. They are part of a kit which is authorized to the maintenance level indicated in the 3rd position of the SMR code. The complete kit must be requisitioned and applied.

MO-Made at unit/
AVUM level
MF-Made at DS/
AVIM level
MH-Made at GS
level
ML-Made at SRA
MD-Made at depot

Items with these codes are not to be requisitioned/requested individually. They must be made from bulk material which is identified by the P/N in the DESCRIPTION AND USABLE ON CODE (UOC) column and listed in the bulk material group work package of the RPSTL. If the item is authorized to you by the 3rd position code of the SMR code, but the source code indicates it is made at higher level, order the item from higher level of maintenance.

AO-Assembled by
unit/AVUM level
AF-Assembled by
DS/AVIM level
AH-Assembled by
GS level
AL-Assembled by
SRA
AD-Assembled by
depot

Items with these codes are not to be requested/requisitioned individually. The parts that make up the assembled item must be requisitioned of fabricated and assembled at the level of maintenance indicated by the source code. If the 3rd position of the SMR code authorizes you to replace the item, but the source code indicates the item is assembled at a higher level, order the item from the the higher level of maintenance.

XA	Do not requisition an "XA" coded item. Order the next higher assembly. (Refer to NOTE below.)
XB	If an item is not available from salvage, order it using the CAGEC and P/N.
XC	Installation drawings, diagrams, instruction sheets, field service drawings; identified by manufacturer's P/N.
XD	Item is not stocked. Order an XD-coded item through normal supply channels using the CAGEC and P/N given, if no NSN is available.

NOTE

Cannibalization or controlled exchange, when authorized, may be used as a source of supply for items with the above source codes except for those items source coded "XA" or those aircraft support items restricted by requirements of AR 750-1.

Maintenance Code. Maintenance codes tell you the level(s) of maintenance authorized to use and repair support items. The maintenance codes are entered in the third and fourth positions of the SMR code as follows:

Third Position. The maintenance code entered in the third position tells you the lowest maintenance level authorized to remove, replace, and use an item. The maintenance code entered in the third position will indicate authorization to the following levels of maintenance:

Maintenance Code

Application/Explanation

- C- Crew or operator maintenance done within unit/AVUM maintenance.
- O- Unit level/AVUM maintenance can remove, replace, and use the item.
- F- Direct support/AVIM maintenance can remove, replace, and use the item.
- H- General support maintenance can remove, replace, and use the item.
- L- Specialized repair activity can remove, replace, and use the item.
- D- Depot can remove, replace, and use the item.

Fourth Position. The maintenance code entered in the fourth position tells you whether or not the item is to be repaired and identifies the lowest maintenance level with the capability to do complete repair (perform all authorized repair functions).

NOTE

Some limited repair may be done on the item at a lower level of maintenance, if authorized by the Maintenance Allocation Chart (MAC) and SMR codes.

**Maintenance
Code****Application/Explanation**

- O - Unit/AVUM is the lowest level that can do complete repair of the item.
- F - Direct support/AVIM is the lowest level that can do complete repair of the item.
- H - General support is the lowest level that can do complete repair of the item.
- L - Specialized repair activity is the lowest level that can do complete repair of the item.
- D - Depot is the lowest level that can do complete repair of the item.
- Z - Nonrepairable. No repair is authorized.
- B - No repair is Authorized. No parts or special tools are authorized for maintenance of "B" coded item. However, the item may be reconditioned by adjusting, lubricating, etc., at the user level.

Recoverability Code. Recoverability codes are assigned to items to indicate the disposition action on unserviceable items. The recoverability code is shown in the fifth position of the SMR code as follows:

**Recoverability
Code****Application/Explanation**

- Z - Nonrepairable item. When unserviceable, condemn and dispose of the item at the level of maintenance shown in the third position of the SMR code.
- O - Repairable item. When uneconomically repairable, condemn and dispose of the item at the unit level.
- F - Repairable item. When uneconomically repairable, condemn and dispose of the item at the direct support level.
- H - Repairable item. When uneconomically repairable, condemn and dispose of the item at the general support level.
- D - Repairable item. When beyond lower level repair capability, return to depot. Condemnation and disposal of item are not authorized below depot level.
- L - Repairable item. Condemnation and disposal of item are not authorized below Specialized Repair Activity (SRA).
- A - Item requires special handling or condemnation procedures because of specific reasons (such as precious metal content, high dollar value, critical material, or hazardous material). Refer to appropriate manuals/directives for specific instructions.

NSN (Column (3)). The NSN for an item is listed in this column.

CAGEC (Column (4)). The commercial and Government Entity Code (CAGEC) is a five-digit code which is used to identify the manufacturer, distributor, or Government agency/activity that supplies the item.

PART NUMBER (Column (5)). Indicates the primary number used by the manufacturer (individual, company, firm, corporation, or Government activity), which controls the design and characteristics of the item by means of its engineering drawings, specifications, standards, and inspection requirements to identify an item or range of items.

NOTE

When you use an NSN to requisition an item, the item you receive may have a different P/N from the one listed.

DESCRIPTION AND USEABLE ON CODE (UOC) (Column (6)). This column includes the following information.

1. The federal item name, and when required, a minimum description to identify the item.
2. P/Ns of bulk materials are referenced in this column in the line entry to be manufactured or fabricated.
3. Hardness Critical Item (HCI). A support item that provides the equipment with special protection from electromagnetic pulse (EMP) damage during a nuclear attack.
4. The statement END OF FIGURE appears just below the last item description column (6) for a given figure in both the repair parts list and the special tools list work packages.

QTY (Column (7)). The QTY (quantity per figure) column indicates the quantity of the item used in the breakout shown on the illustration/figure, which is prepared for a functional group, subfunctional group, or an assembly. A "V" appearing in this column instead of a quantity indicates that the quantity is variable and quantity may change from application to application.

EXPLANATION OF CROSS-REFERENCE INDEXES WORK PACKAGES FORMAT AND COLUMNS

1. National Stock Number (NSN) Index Work Package.

STOCK NUMBER Column. This column lists the NSN in National item identification number (NIIN) sequence. The NIIN consists of the last nine digits of the NSN.

NSN
 (e.g., 5385-01-574-1476)
 NIIN

When using this column to locate an item, ignore the first four digits of the NSN. However the complete NSN should be used when ordering items by stock number.

FIG. Column. This column lists the number of the figure where the item is identified/located. The figures are in numerical order in the repair parts list and special tools list work packages.

ITEM Column. The item number identifies the item associated with the figure listed in the adjacent FIG. column. This item is also identified by the NSN listed on the same line.

2. Part Number (P/N) Index Work Package. P/Ns in this index are listed in ascending alphanumeric sequence (vertical arrangement of letter and number combinations which places the first letter or digit of each group in order A through Z, followed by the numbers 0 through 9 and each following letter or digit in like order).

RPSTL INTRODUCTION0062 00

PART NUMBER Column. Indicates the P/N assigned to the item.

FIG. Column. This column lists the number of the figure where the item is identified/located in the repair parts list and special tools list work packages.

ITEM Column. The item number is the number assigned to the item as it appears in the figure referenced in the adjacent figure number column.

SPECIAL INFORMATION

UOC. The UOC appears in the lower left corner of the Description Column heading. Useable on codes are shown as "UOC: ..." in the Description Column (justified left) on the first line under the applicable item/nomenclature. Uncoded items are applicable to all models. Identification of the UOCs used in the RPSTL are:

<u>Code</u>	<u>Used On</u>
717	M105A3

Fabrication Instructions. Bulk materials required to manufacture items are listed in the bulk material functional group of this RPSTL. Part numbers for bulk materials are also referenced in the Description Column of the line item entry for the item to be manufactured/fabricated. Detailed fabrication instructions for items source coded to be manufactured or fabricated are found in Appendix (x) of this manual.

Index Numbers. Items which have the word BULK in the figure column will have an index number shown in the item number column. This index number is a cross-reference between the NSN / P/N index work packages and the bulk material list in the repair parts list work package.

HOW TO LOCATE REPAIR PARTS

1. When NSNs or P/Ns Are Not Known.

First. Using the table of contents, determine the assembly group to which the item belongs. This is necessary since figures are prepared for assembly groups and subassembly groups, and lists are divided into the same groups.

Second. Find the figure covering the functional group or the subfunctional group to which the item belongs.

Third. Identify the item on the figure and note the number(s).

Fourth. Look in the repair parts list work packages for the figure and item numbers. The NSNs and part numbers are on the same line as the associated item numbers.

2. When NSN Is Known.

First. If you have the NSN, look in the STOCK NUMBER column NSN index work package. The NSN is arranged in NIIN sequence. Note the figure and item number next to the NSN.

Second. Turn to the figure and locate the item number. Verify that the item is the one you are looking for.

RPSTL INTRODUCTION

0062 00

3. When P/N Is Known.

First. If you have the P/N and not the NSN look in the PART NUMBER column of the part number index work package. Identify the figure and item number.

Second. Look up the item on the figure in the applicable repair parts list work package.

ABBREVIATIONS

No uncommon abbreviations are used in this RPSTL.

GROUP 0609 REAR COMPOSITE MARKER LIGHT

0063 00

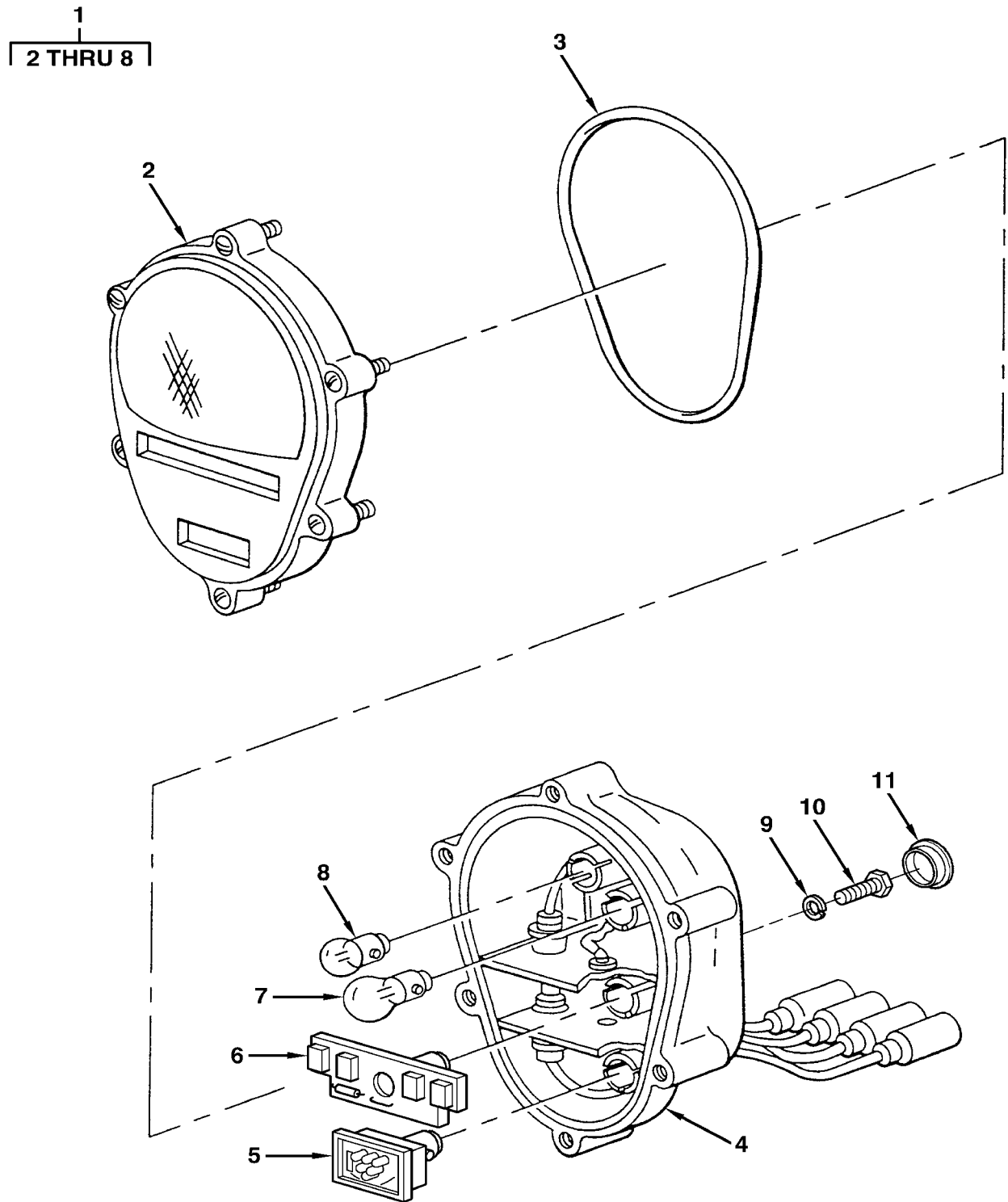

FIGURE 1. REAR COMPOSITE MARKER LIGHT

GROUP 0609 REAR COMPOSITE MARKER LIGHT REPAIR PARTS LIST - Continued

0063 00

(1) ITEM NO.	(2) SMR CODE	(3) NSN	(4) CAGEC	(5) PART NUMBER	(6) DESCRIPTION AND USABLE ON CODE (UOC)	(7) QTY
GROUP 0609 LIGHTS						
FIG. 1 REAR COMPOSITE MARKER LIGHT						
DBGS	1 PF000	6220-01-093-4439	96906	MS52125-2	STOP LIGHT-TAILLIGHT COMPOSITE.....	2
DBGW	2 PAOZZ	6220-00-179-4324	19207	11639535	LENS LIGHT.....	1
DBHA	3 PAOZZ	5331-00-462-0907	19207	11639519-2	PACKING,PREFORMED.....	1
DBHE	4 XAOZZ	6220-01-067-4717	19207	11639520	BODY ASSEMBLY.....	1
DBHJ	5 PAOZZ	6220-01-297-3217	19207	12360870-2	DIODE,LIGHT EMITTING.....	1
DBHN	6 PAOZZ	6220-01-284-2709	19207	12360850-1	DIODE,LIGHT EMITTING.....	1
DBHS	7 PAOZZ	6240-01-447-3779	81348	A-A-52463-B10	LAMP,INCANDESCENT.....	1
DBHW	8 PAOZZ	6240-00-019-3093	58536	A52463-1-09	LAMP,INCANDESCENT.....	1
DBJA	9 PAOZZ	5310-00-637-9541	96906	MS35338-46	WASHER,LOCK 3/8.....	4
DBJEA	10 PAOZZ	5305-00-115-9526	80204	B1821BH038C075D	SCREW,CAP,HEXAGON,H 3/8-16X3/4 GR 5.....	4
DBJJA	11 PAOZZ		7J015	1055070	PLUG.....	4
END OF FIGURE						

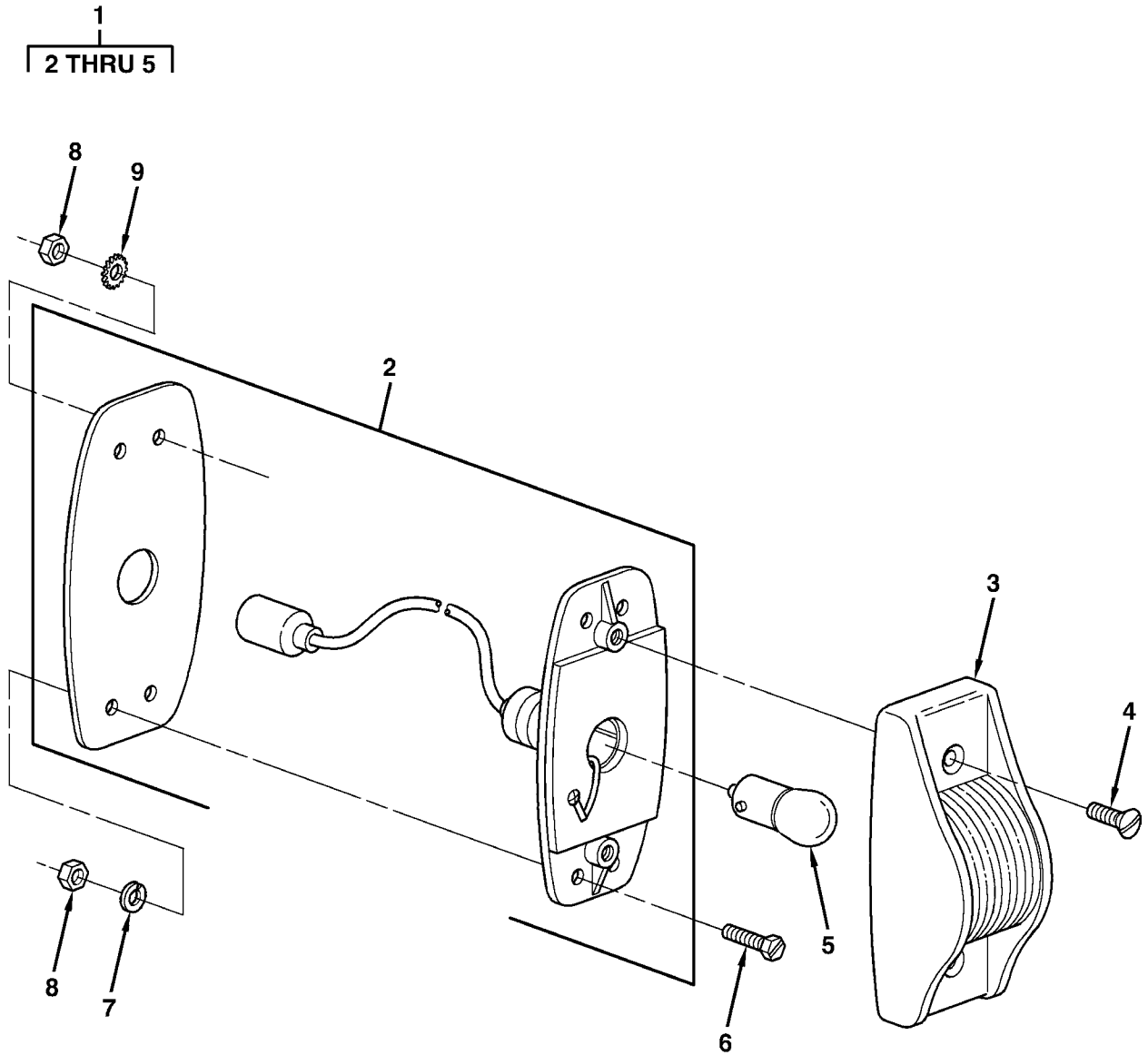

FIGURE 2. RUNNING LIGHTS

GROUP 0609 RUNNING LIGHTS REPAIR PARTS LIST - Continued

0064 00

(1) ITEM NO.	(2) SMR CODE	(3) NSN	(4) CAGEC	(5) PART NUMBER	(6) DESCRIPTION AND USABLE ON CODE (UOC)	(7) QTY
GROUP 0609 LIGHTS						
FIG. 2 RUNNING LIGHTS						
DBAEA	1 PA000	6220-00-726-1916	96906	MS35423-2	LIGHT, MARKER CLEARANCE RED .	5
DBAD	2 XA0ZZ	6220-00-729-9295	96906	MS35422-1	LIGHT BODY	5
DBAJ	3 PA0ZZ	6220-00-299-7426	96906	MS35421-2	LENS, RED	5
DBAN	4 PA0ZZ	5305-00-984-6214	96906	MS35206-267	SCREW, MACHINE #10-24X1...	10
DBAS	5 PA0ZZ	6240-00-019-0877	80204	1251	LAMP	5
DBAWA	6 PA0ZZ	5305-00-240-0194	96906	MS51849-76	SCREW, MACHINE 3/16-24X3/4 .	20
DBBAA	7 PA0ZZ	5310-00-043-2226	96906	MS35338-24	WASHER, LOCK NO 10	15
DBBE	8 PA0ZZ	5310-00-934-9758	96906	MS35649-202	NUT, PLAIN HEXAGON 3/16-24 .	20
DBBJ	9 PA0ZZ	5310-00-596-7691	96906	MS35335-32	WASHER, LOCK #10	5
END OF FIGURE						

1
| 2 THRU 8 |

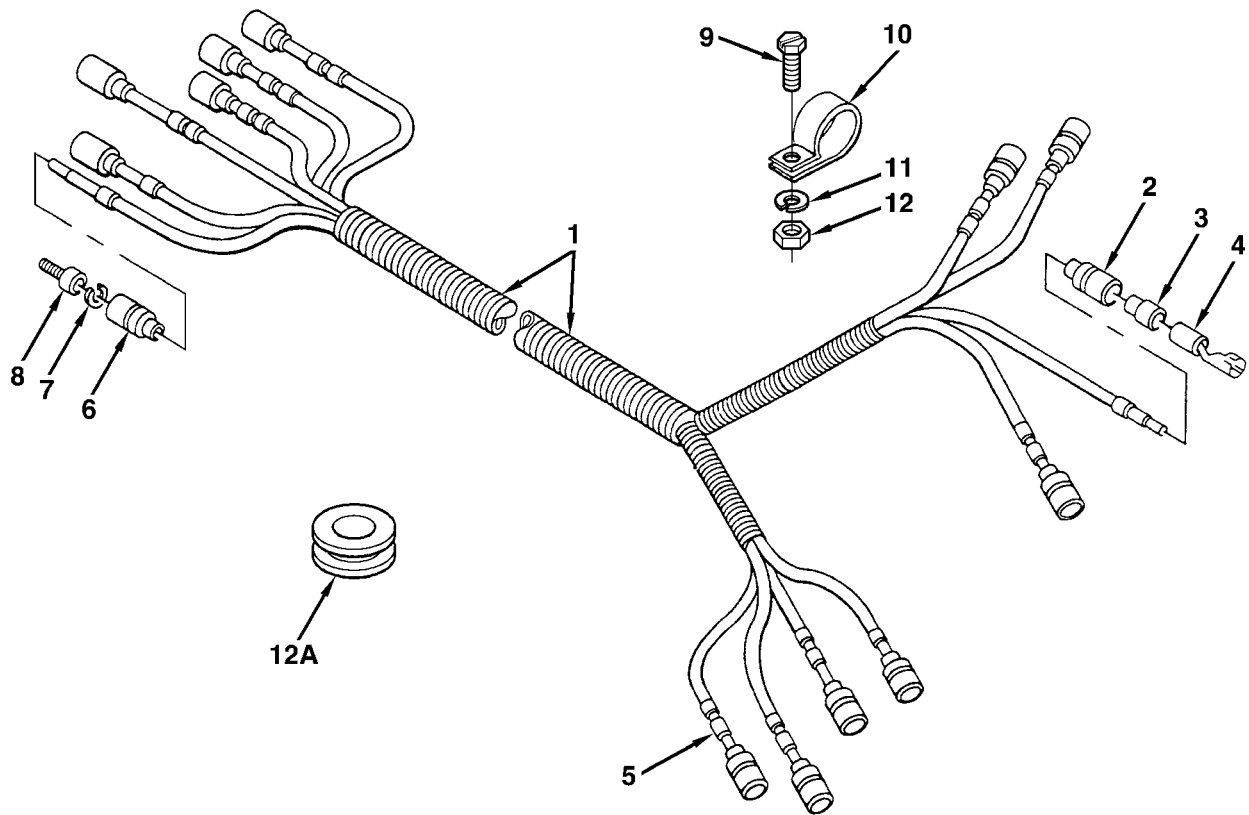

FIGURE 3. CHASSIS WIRING HARNESS

14
|
15 AND 16 |

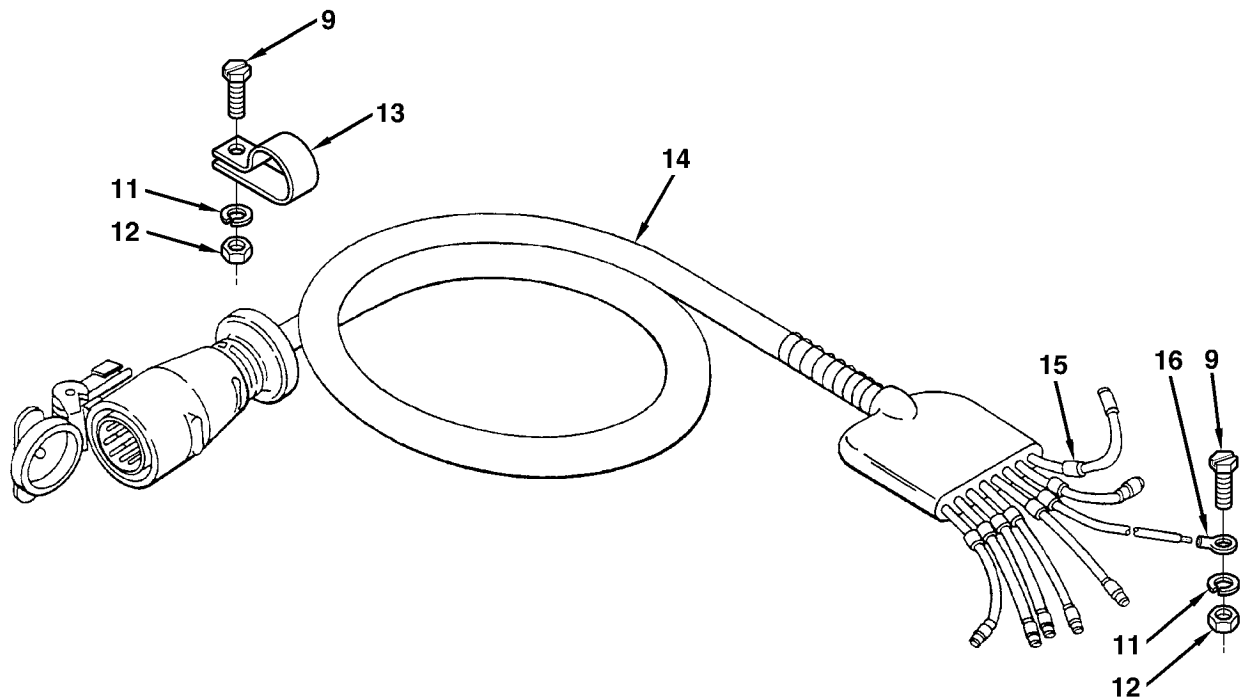

FIGURE 3. CHASSIS WIRING HARNESS

GROUP 0613 CHASSIS WIRING HARNESS

0065 00

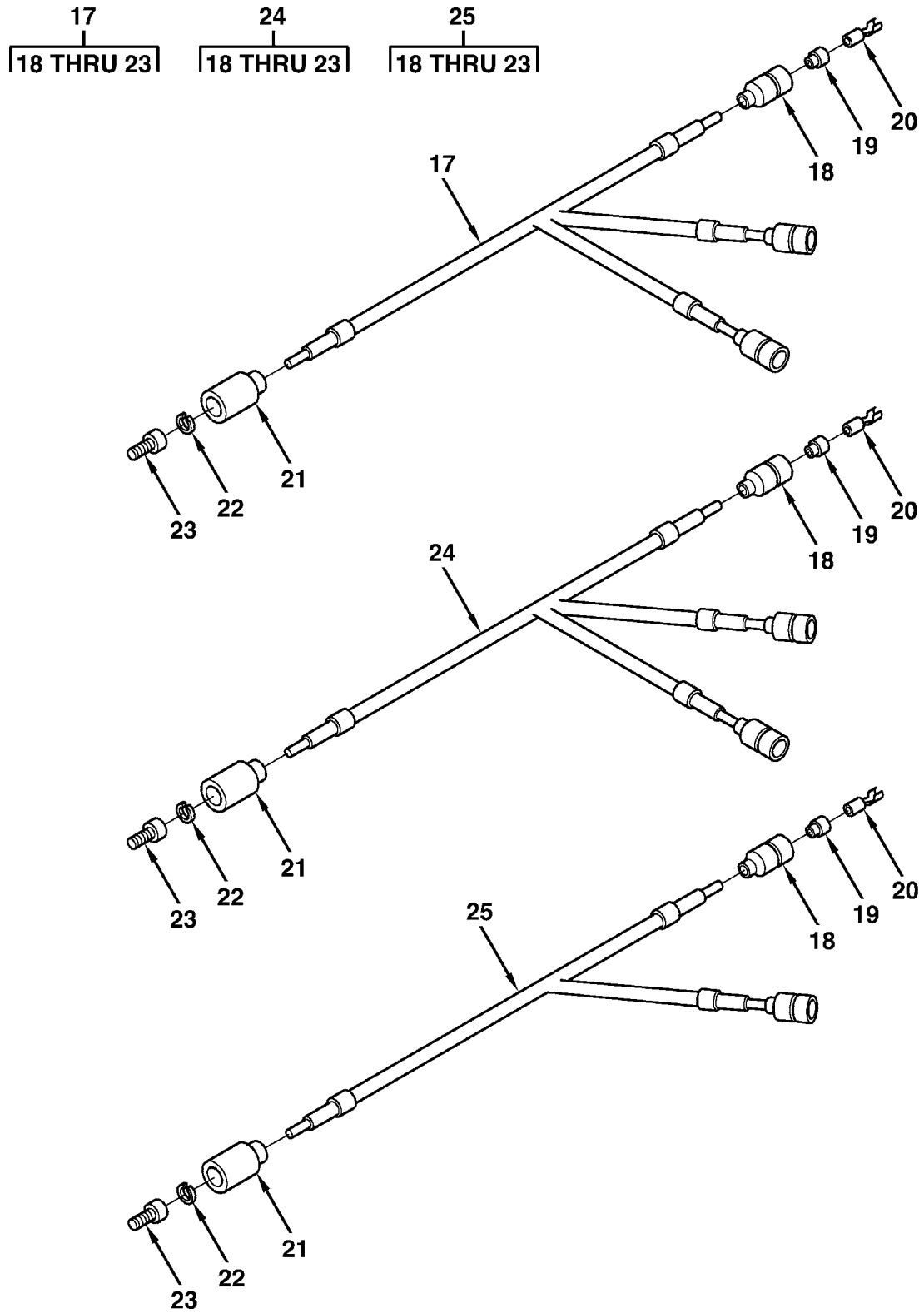

FIGURE 3. CHASSIS WIRING HARNESS

GROUP 0613 CHASSIS WIRING HARNESS REPAIR PARTS LIST - Continued

0065 00

(1) ITEM NO.	(2) SMR CODE	(3) NSN	(4) CAGEC	(5) PART NUMBER	(6) DESCRIPTION AND USABLE ON CODE (UOC)	(7) QTY
					GROUP 0613 HULL OR CHASSIS WIRING HARNESS	
					FIG. 3 CHASSIS WIRING HARNESS	
DBCJ	1 PA000	5845-01-168-0148	7J015	1055020	HARNESS,WIRING	1
DBCN	2 PAOZZ	5935-00-833-8561	19207	8338561	SHELL, ELECTRICAL	8
DBCS	3 PAOZZ	5970-00-833-8562	19207	8338562	INSULATOR, BUSHING	8
DBCW	4 PAOZZ	5940-00-399-6676	19207	8338564	TERMINAL ASSEMBLY	8
DBDA	5 PAOZZ		96906	MS39020-1	BAND MARKER	22
DBDE	6 PAOZZ	5935-00-572-9180	19207	8338566	SHELL, ELECTRICAL	6
DBDJ	7 PAOZZ	5310-00-833-8567	19207	8338567	WASHER,SLOTTED	6
DBDN	8 PAOZZ	5999-00-057-2929	19204	572929	CONTACT, ELECTRICAL	6
DBDSA	9 PAOZZ	5305-00-240-0194	96906	MS51849-76	SCREW,MACHINE NO 10-24X3/4 .	12
DBDW	10 PAOZZ	5340-00-057-2904	96906	MS21333-71	CLAMP, LOOP	12
DBEA	11 PAOZZ	5310-00-045-3296	96906	MS35338-43	WASHER,LOCK NO 10	12
DBEE	12 PAOZZ	5310-00-934-9758	96906	MS35649-202	NUT, PLAIN, HEXAGON NO 10-24	12
DBEK	13 PAOZZ		7J015	1055090	GROMMET	4
DBENA	14 PAOZZ	5340-01-487-5091	7J015	1055005	STRAP, RUBBERIZED 3/4	1
DBESA	15 PA000	6150-01-492-2003	7J015	1055030	CABLE ASSEMBLY	1
DBEW	16 PAOZZ		96906	MS39020-1	BAND MARKER	8
DBFA	17 PAOZZ	5940-00-230-0515	81343	AS25036-154	TERMINAL, LUG	1
DBFE	18 PA000	6150-01-492-2004	7J015	1055040	HARNESS,WIRING	1
DBFJ	19 PAOZZ	5935-00-833-8561	19207	8338561	SHELL, ELECTRICAL	8
DBFN	20 PAOZZ	5970-00-833-8562	19207	8338562	INSULATOR, BUSHING	8
DBFS	21 PAOZZ	5940-00-399-6676	19207	8338564	TERMINAL ASSEMBLY	8
DBFW	22 PAOZZ	5835-00-572-9180	19207	8338566	SHELL, ELECTRICAL	3
DBGA	23 PAOZZ	5310-00-833-8567	19207	8338567	WASHER,SLOTTED	3
DBGE	24 PAOZZ	5999-00-057-2929	19204	572929	CONTACT	3
DBGJ	25 PA000	6150-01-492-2005	7J015	1055050	HARNESS,WIRING	1
DBGN	26 PA000	6150-01-492-2006	7J015	1055060	HARNESS,WIRING	1
					END OF FIGURE	

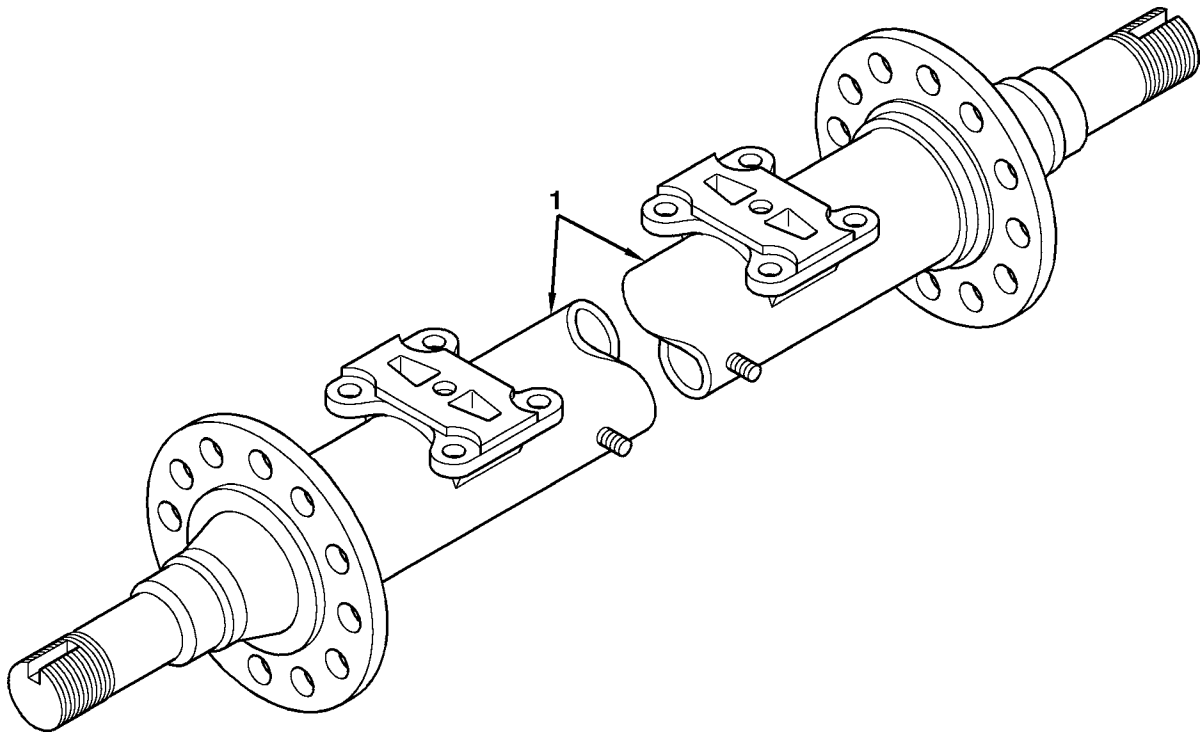

FIGURE 4. REAR AXLE

GROUP 1100 REAR AXLE REPAIR PARTS LIST - Continued

0066 00

(1) ITEM NO.	(2) SMR CODE	(3) NSN	(4) CAGEC	(5) PART NUMBER	(6) DESCRIPTION AND USABLE ON CODE (UOC)	(7) QTY
					GROUP 1100 REAR AXLE	
					FIG. 4 REAR AXLE	
DJACA	1 XBFZZ		7J015	1056100	REAR AXLE	1
					END OF FIGURE	

GROUP 1201 HANDBRAKE LINKAGE

0067 00

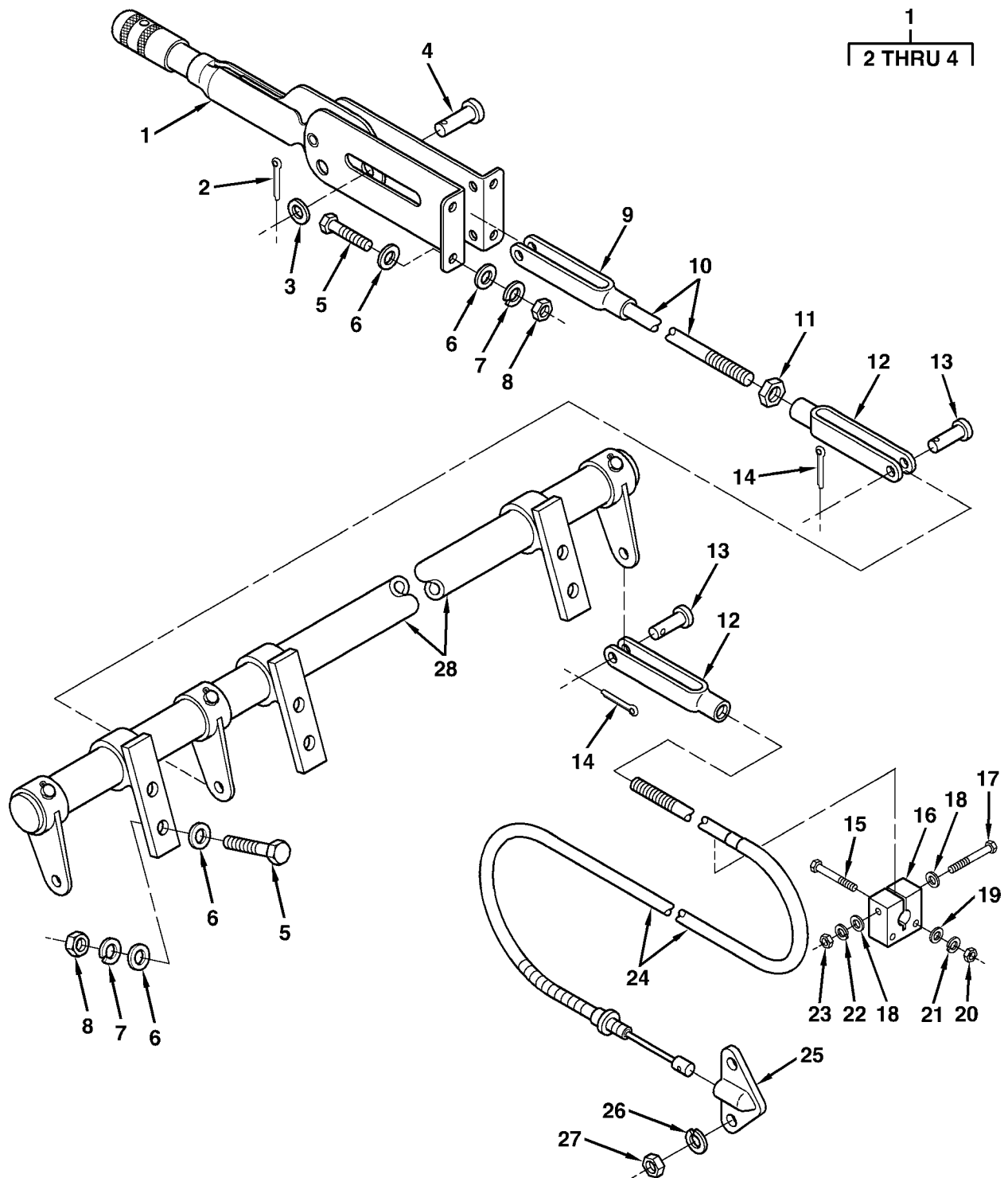

FIGURE 5. HANDBRAKE LINKAGE

GROUP 1201 HANDBRAKE LINKAGE REPAIR PARTS LIST - Continued

0067 00

(1) ITEM NO.	(2) SMR CODE	(3) NSN	(4) CAGEC	(5) PART NUMBER	(6) DESCRIPTION AND USABLE ON CODE (UOC)	(7) QTY
GROUP 1201 HANDBRAKE						
FIG. 5 HANDBRAKE LINKAGE						
DDAE	1 PA000	3040-01-169-7388	92867	02183400	HANDBRAKE.....	1
DDAJ	2 PA0ZZ	5315-01-359-1451	80205	MS24665-285	PIN,COTTER 3/32x1.....	1
DDAS	3 PA0ZZ	5310-00-081-4219	96906	MS27183-12	FLATWASHER 11/32.....	1
DDAV	4 PA0ZZ	5315-00-903-5943	96906	MS20392-4C39	PIN,STRAIGHT HEADED 5/16x1 7/32.....	1
DDAW	5 PA0ZZ	5306-00-225-8499	96906	MS90725-34	BOLT, MACHINE 5/16-18X1....	10
DDBEA	6 PA0ZZ	5310-00-809-3078	96906	MS27183-11	FLATWASHER 5/16.....	20
DDBJ	7 PA0ZZ	5310-00-407-9566	96906	MS35338-45	WASHER,LOCK 5/16.....	12
DDBS	8 PA0ZZ	5310-00-880-7744	96906	MS51967-5	NUT, PLAIN HEXAGON 5/16-18.	10
DDCJ	9 PA0ZZ	5340-01-487-5752	7J015	1053075	SPECIAL LINKAGE.....	1
DDBU	10 PA0ZZ	5306-01-487-5691	7J015	1053080	ROD ASSEMBLY.....	1
DDCS	11 PA0ZZ	5310-00-732-0559	96906	MS51968-8	NUT, PLAIN HEXAGON 3/8-24..	1
DDBN	12 PA0ZZ	5340-01-487-5368	7J015	1053070	LINKAGE.....	3
DDCE	13 PA0ZZ	5315-00-825-8353	96906	MS20392-5C29	PIN,STRAIGHT HEADED 3/8X29/32.....	3
DDAJ	14 PA0ZZ	5315-01-359-1451	80205	MS24665-285	PIN, COTTER 3/32x1.....	3
DDDA	15 PA0ZZ	5306-01-303-2815	96906	MS90725-13	SCREW 1/4-20X1 3/4.....	4
DDDE	16 PA0ZZ	5340-01-492-0907	7J015	1053095	BLOCK,CABLE.....	2
DDDJA	17 PA0ZZ	5305-00-543-2866	80204	B1821BH038C250N	SCREW, CAP, HEXAGON HEAD 3/8-16X2 1/2.....	2
DDDM	18 PA0ZZ	5310-00-080-6004	96906	MS27183-14	FLATWASHER 3/8.....	4
DDDN	19 PA0ZZ	5310-00-619-4848	96906	99-51505-017	FLATWASHER 1/4.....	8
DDDSA	20 PA0ZZ	5310-00-761-6882	96906	MS51967-2	NUT, PLAIN, HEXAGON 14/20..	4
DDDW	21 PA0ZZ	5310-00-582-5965	96906	MS35338-44	WASHER,LOCK 1/4.....	4
DDDZ	22 PA0ZZ	5310-00-543-2705	96906	MS35338-27	WASHER,LOCK 3/8.....	2
DDEAA	23 PA0ZZ	5310-00-732-0558	96906	MS51967-8	NUT,PLAIN,HEXAGON 3/8-16...	2
DJEA	24 PA0ZZ	2530-00-441-0210	58536	A-A-52168-4	CABLE ASSEMBLY.....	2
DDEJ	25 PA0ZZ	5342-00-991-4342	30076	339589	GUIDE,BRACKET LH.....	1
DDEN	25 PA0ZZ	5342-00-987-2565	63477	F19636	GUIDE,BRACKET RH.....	1
DDER	26 PA0ZZ	5310-00-274-8715	96906	MS35338-63	WASHER,LOCK 1/4.....	4
DDES	27 PA0ZZ	5310-00-761-6882	96906	MS51967-2	NUT,PLAIN,HEXAGON 14/20....	4
DDAN	28 PA0ZZ	3040-01-487-5119	7J015	1053010	SHAFT ASSEMBLY.....	1
END OF FIGURE						

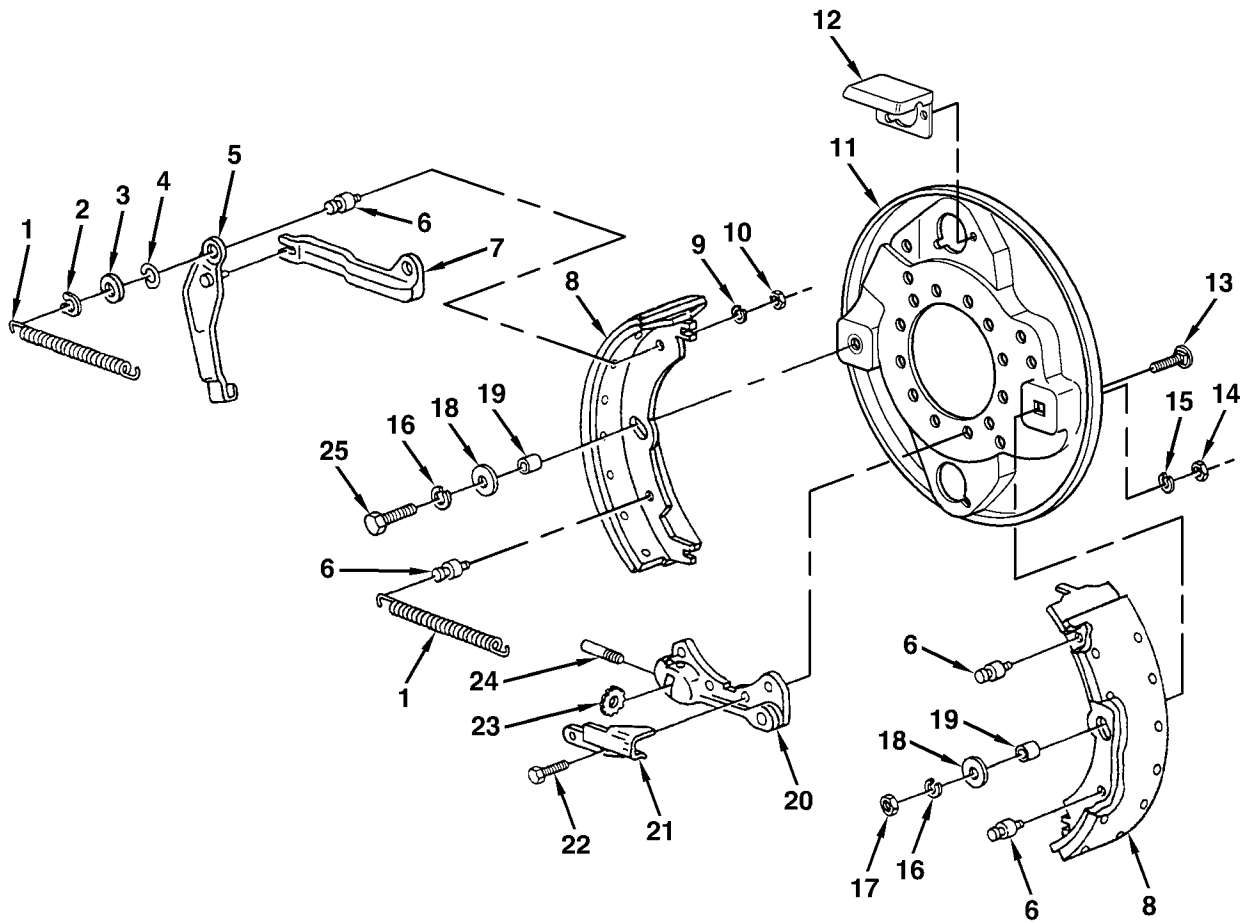

FIGURE 6. SERVICE BRAKE

GROUP 1202 SERVICE BRAKE REPAIR PARTS LIST - Continued

0068 00

(1) ITEM NO.	(2) SMR CODE	(3) NSN	(4) CAGEC	(5) PART NUMBER	(6) DESCRIPTION AND USABLE ON CODE (UOC)	(7) QTY
GROUP 1202 SERVICE BRAKES						
FIG. 6 SERVICE BRAKE						
DKLA	1 PAOZZ	5360-00-699-9018	19207	8720515	SPRING,HELICAL.....	8
DKFG	2 PAOZZ	5310-00-322-7260	19207	8733937	WASHER,SLOTTED 1.....	8
DKRG	3 PAOZZ	5310-00-314-0765	19207	8733936	FLATWASHER 7/8.....	8
DKGA	4 PAOZZ	5310-00-314-0764	19207	8733935	WASHER,SPRING 7/8.....	8
DKUEA	5 PAOZZ	2530-00-973-2355	19207	8733911	LEVER,BRAKE LH.....	1
DKUN	5 PAOZZ	2530-00-973-2356	19207	8733912	LEVER,BRAKE RH.....	1
DKRN	6 PAOZZ	5315-00-322-7261	63477	FC-17758	PIN, SERVICE BRAKE 13/32X5/32	8
DKQU	7 PAOZZ	3040-00-150-7127	19207	8733926	CONNECTING LINK,LH.....	1
DLGA	7 PAOZZ	3040-00-074-2357	19207	8733927	CONNECTING LINK,RH.....	1
DKDU	8 PAOZZ	2530-00-693-1007	78500	A8-3222W855	BRAKE SHOE.....	4
DKSA	9 PFOZZ	5310-00-209-5116	96906	MS35335-37	WASHER,LOCK 1/2.....	8
DKSE	10 PAOZZ	5310-00-903-3993	96906	MS51970-4	NUT,PLAIN, HEXAGON 7/16-20.	8
DKGGA	11 PAOZZ	2530-01-083-5641	19207	8733933	PLATE,BACKING.....	2
DKSJ	12 PAOZZ	2530-00-741-2068	19207	7412068	SHIELD,BRAKE LH.....	2
DKSN	12 PAOZZ	2530-00-741-2050	63477	F9556	SHIELD,BRAKE RH.....	2
DKKNA	13 PAOZZ	5306-00-741-1760	19207	7411760	BOLT,GUIDE 1/4-28X7/8.....	2
DKTA	14 PAOZZ	5310-00-732-0559	96906	MS51968-8	NUT,PLAIN,HEXAGON 3/8-24...	24
DKTE	15 PAOZZ	5310-00-627-6128	96906	MS35335-35	WASHER,LOCK 25/64.....	24
DKTJ	16 PAOZZ	5310-00-582-5965	96906	MS35338-44	WASHER,LOCK 1/4.....	4
DKTN	17 PAOZZ	5310-00-924-4218	96906	MS51970-1	NUT,PLAIN,HEXAGON 1/4-28...	4
DKTS	18 PAOZZ	5310-00-641-9939	19207	5323088	FLATWASHER 17/64.....	4
DKKP	19 PAOZZ	5365-00-741-2103	19207	7412103	SLEEVE,SPACER.....	4
DKHA	20 PAOZZ	2530-00-159-8755	19207	8733908	SUPPORT ASSY LH.....	2
DLCU	20 PAOZZ	2530-00-159-8756	19207	8733909	SUPPORT ASSY RH	2
DLCGA	21 PAOZZ	2530-00-522-1157	19207	8733892	RAMP,CABLE,LH.....	2
DLBA	21 PAOZZ	2530-00-794-9763	21450	8733893	RAMP,CABLE,RH.....	2
DKTW	22 PAOZZ	5305-00-269-2804	96906	MS90726-61	SCREW,CAP,HEXAGO HEAD 3/8-24X1 1/8.....	8
DKHN	23 PAOZZ	5305-00-770-9149	63477	FC22219	WHEEL,SLACK ADJUS.....	4
DKHG	24 PAOZZ	2530-00-770-9150	19207	8336705	SCREW,BRAKE ADJ LH.....	2
DLDA	24 PAOZZ	2530-00-770-9151	19207	8336789	SCREW,BRAKE ADJ RH.....	2
DLDG	25 PAOZZ	5305-00-269-3241	96906	MS90726-65	SCREW,CAP,HEXAGON HEAD 3/8-24X1 3/4.....	16
DKUA	26 PAOZZ	5305-00-068-0515	80204	B1821BH025F100N	SCREW,CAP,HEXAGON HEAD 1/4-28X1.....	2
END OF FIGURE						

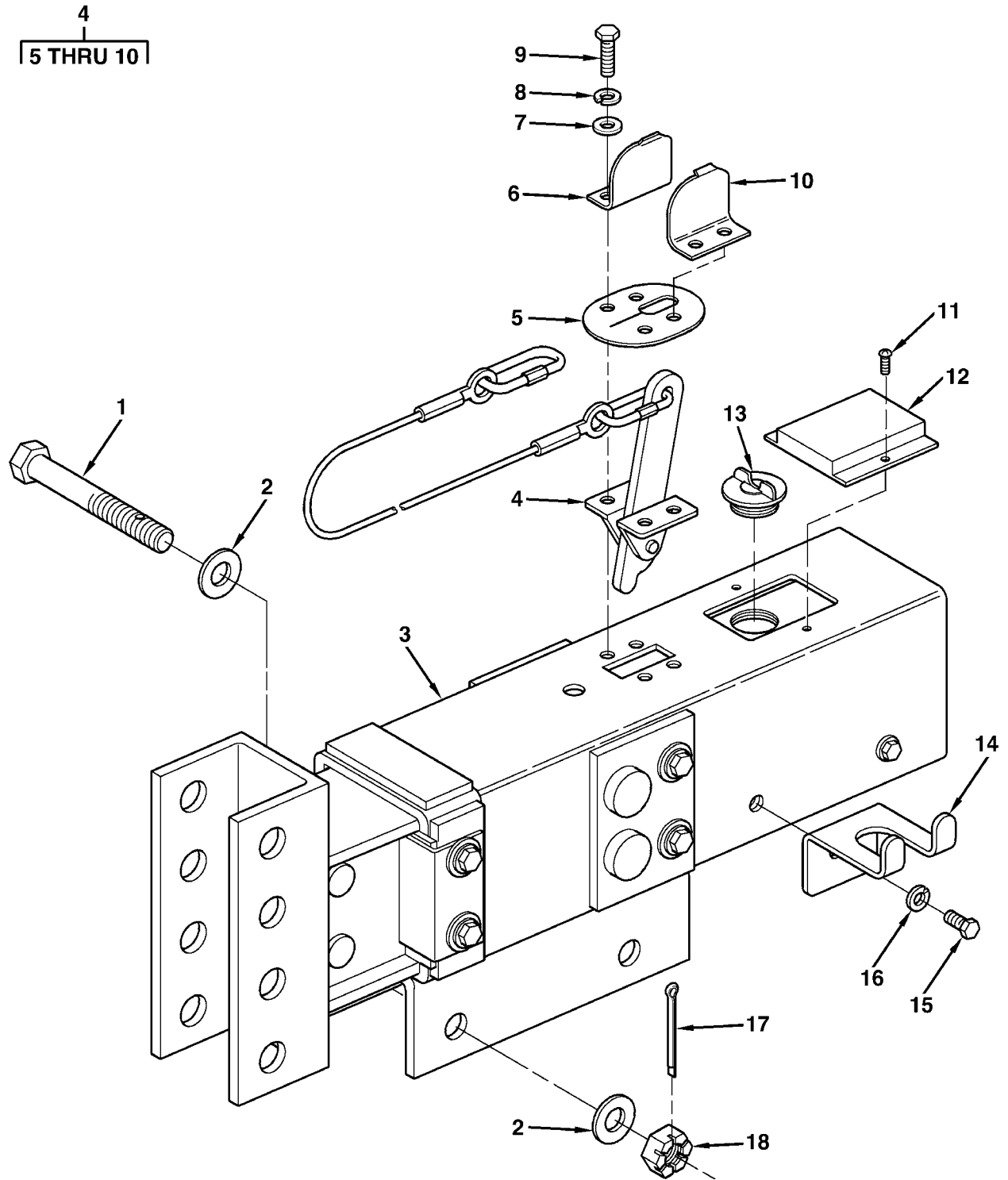

FIGURE 7. BRAKES ACTUATOR ASSEMBLY

GROUP 1204 BRAKES ACTUATOR ASSEMBLY REPAIR PARTS LIST - Continued

0069 00

(1) ITEM NO.	(2) SMR CODE	(3) NSN	(4) CAGEC	(5) PART NUMBER	(6) DESCRIPTION AND USABLE ON CODE (UOC)	(7) QTY
GROUP 1204 HYDRAULIC BRAKE SYSTEM						
FIG. 7 BRAKES ACTUATOR ASSEMBLY						
DCAEA	1 PAOZZ	5306-01-492-0980	7J015	1054610-1	BOLT.....	1
DCAJ	2 PAOZZ	5310-00-809-8533	96906	MS27183-23	FLATWASHER 13/16.....	2
DCAN	3 PAOZZ	2350-01-492-2215	7J015	1054100	ACTUATOR.....	1
DCASA	4 XAOZZ		7J015	1054400	BREAKAWAY LEVER ASSEMBLY ...	1
DCAWA	5 XAOZZ		7J015	1054440	GASKET.....	1
DCBAA	6 XAOZZ		7J015	1054430-1	BREAKAWAY LOCK RH.....	1
DCBE	7 PAOZZ	5310-00-081-4219	96906	MS27183-12	FLATWASHER 11/32.....	4
DCBJ	8 PAOZZ	5310-00-407-9566	96906	MS35338-45	WASHER, LOCK 5/16.....	4
DCBN	9 PAOZZ	5306-01-362-2851	96906	MS90725-32	BOLT, MACHINE 5/16-18X3/4..	4
DCBSA	10 XAOZZ		7J015	1054430-2	BREAKAWAY LOCK LH.....	1
DCCE	11 PAOZZ	5305-00-052-9051	80205	MS24630-36	SCREW, TAPPING 8-32X1 1/2...	2
DCCJ	12 PAOZZ	5340-01-492-0911	7J015	1054570	COVER.....	1
DCCL	13 PAOZZ		7J015	1054516	CAP, MASTER CYLINDER.....	1
DCCM	14 PAOZZ		7J015	1054480	HOLDER, ELECTRIC CABLE.....	1
DCCNA	15 PAOZZ	5306-00-225-8496	96906	MS90725-31	BOLT, MACHINE 5/16-18X5/8 GR 5.....	1
DCCP	16 PAOZZ	5310-00-407-9566	96906	MS35338-45	WASHER, LOCK 5/16.....	1
DCCR	17 PAOZZ	5315-00-013-7228	80205	MS24665-423	PIN, COTTER 5/32X1 1/2.....	1
DCCS	18 PAOZZ	5310-00-850-6881	96906	MS35692-57	NUT, PLAIN, SLOTTED, HEXAGON 3/4-10.....	1
END OF FIGURE						

1
|
2 THRU 4 |

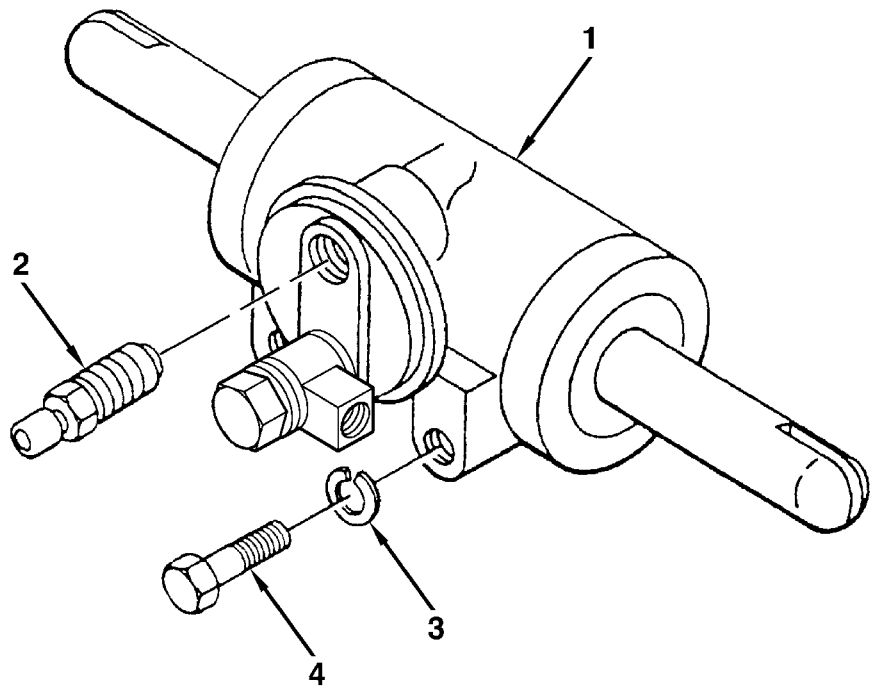

FIGURE 8. WHEEL CYLINDER

GROUP 1204 WHEEL CYLINDER REPAIR PARTS LIST - Continued

0070 00

(1) ITEM NO.	(2) SMR CODE	(3) NSN	(4) CAGEC	(5) PART NUMBER	(6) DESCRIPTION AND USABLE ON CODE (UOC)	(7) QTY
					GROUP 1204 HYDRAULIC BRAKE SYSTEM	
					FIG. 8 WHEEL CYLINDER	
DKMGA	1 PAOZZ	2530-00-741-2065	63477	F14413	CYLINDER ASSEMBLY	1
DKMA	2 PAOZZ	2530-00-737-3260	19207	7373260	VALVE,BLEEDER	4
DKME	3 PAOZZ	5310-00-261-7340	96906	MS35338-8	WASHER,LOCK 3/8	8
DKMJ	4 PAOZZ	5305-00-115-9526	80204	B1821BH038C075D	SCREW,CAP,HEXAGON 3/8-16X3/4	8
					END OF FIGURE	

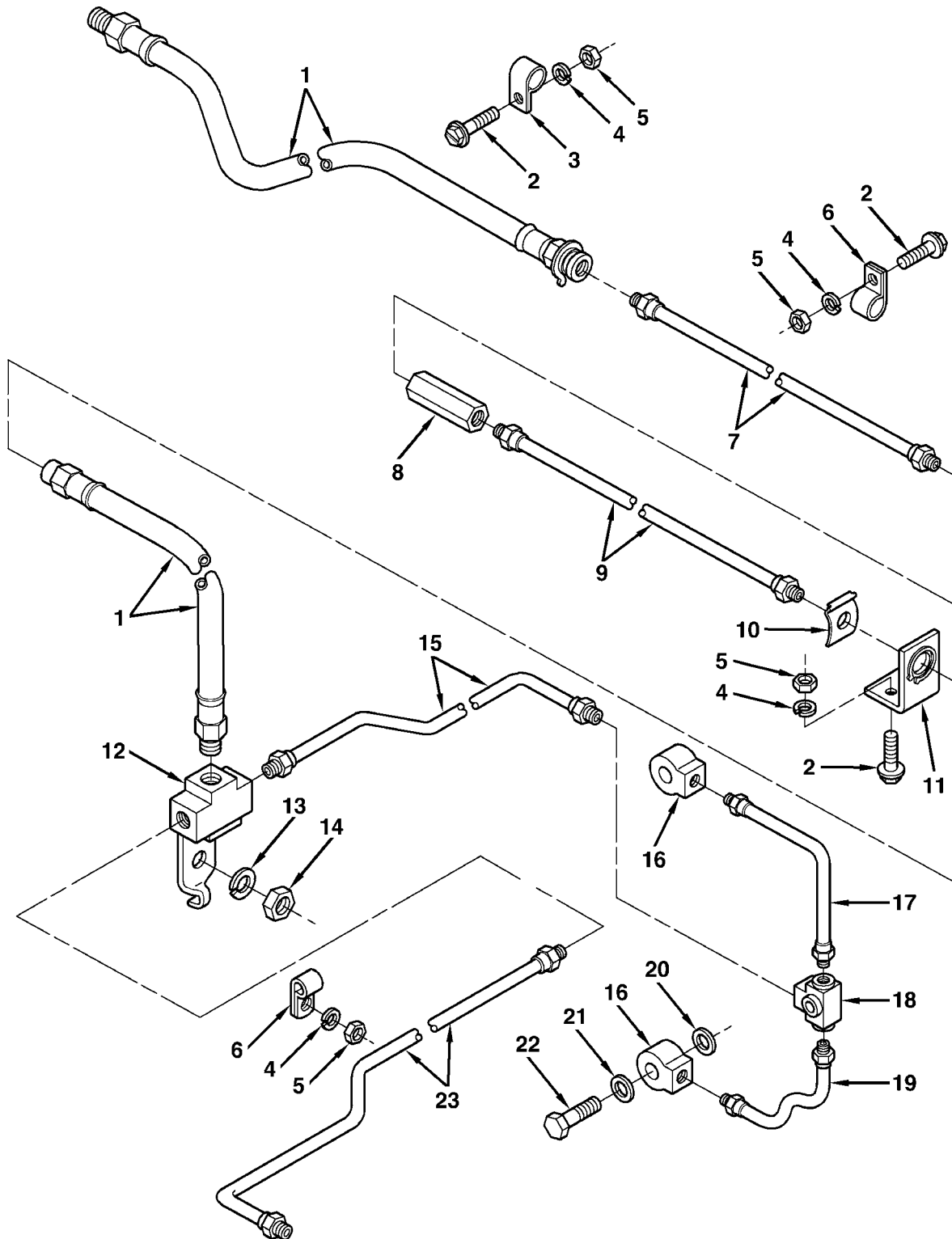

FIGURE 9. HYDRAULIC BRAKE LINES AND FITTINGS

**GROUP 1204 HYDRAULIC BRAKE LINES AND FITTINGS
REPAIR PARTS LIST - Continued**

0071 00

(1) ITEM NO.	(2) SMR CODE	(3) NSN	(4) CAGEC	(5) PART NUMBER	(6) DESCRIPTION AND USABLE ON CODE (UOC)	(7) QTY
					GROUP 1204 HYDRAULIC BRAKE SYSTEM	
					FIG. 9 HYDRAULIC BRAKE LINES AND FITTINGS	
DCDA	1 PAOZZ		7J015	1054010	HOSE	2
DCDEA	2 PAOZZ	5305-00-240-0194	96906	MS51849-76	SCREW,MACHINE NO 10-24X3/4 .	6
DCDG	3 PAOZZ	5340-00-057-2904	96906	MS21333-71	CLAMP,LOOP	1
DCDN	4 PAOZZ	5310-00-045-3296	96906	MS35338-43	WASHER,LOCK NO 10	6
DCDS	5 PAOZZ	5310-00-934-9758	96906	MS35649-202	NUT,PLAIN,HEXAGON 3/16-24 ..	6
DCDJ	6 PAOZZ	5340-01-492-0912	7J015	1054020	CLAMP	4
DCDW	7 PAOZZ	4710-01-492-2219	7J015	1054030	TUBE	1
DCEA	8 PAOZZ	4735-01-492-2221	7J015	1054035	UNION	1
DCEE	9 PAOZZ	4710-01-492-2225	7J015	1054040	TUBE	1
DCEJ	10 PAOZZ	5340-01-492-0919	7J015	1054043	CLIP	1
DCEN	11 PAOZZ	5340-01-492-0922	7J015	1054045	BRACKET	1
DCES	12 PAOZZ	4730-01-492-2227	7J015	1054047	UNION TEE	1
DCEW	13 PAOZZ	5310-00-582-5965	96906	MS35338-44	WASHER,LOCK 1/4	1
DCFA	14 PAOZZ	5310-00-761-6882	96906	MS51967-2	NUT,PLAIN,HEXAGON 1/4-20 ...	1
DCFE	15 PAOZZ	4710-01-492-2229	7J015	1054050	TUBE ASSEMBLY,METALLIC	1
DCFJ	16 PAOZZ	4730-00-419-9425	19207	7745464	CONNECTOR,MULTIPLE	4
DCFN	17 PAOZZ	4710-00-741-1907	63477	FD13351	TUBE ASSEMBLY,RH	1
DKAN	17 PAOZZ	4710-00-566-7133	19207	8733920	TUBE ASSEMBLY,LH	1
DCFW	18 PAOZZ	4730-00-741-1903	56190	FC13927	FITTING	2
DLAN	19 PAOZZ	4710-00-630-9928	19207	8733918	TUBE ASSEMBLY,RH	1
DKAU	19 PAOZZ	4710-00-566-7134	19207	8733922	TUBE ASSEMBLY,LH	1
DKBN	20 PAOZZ	5310-00-741-2088	19207	7412088	SPACER	4
DKBU	21 PAOZZ	5365-00-274-4544	19207	5298653	SPACER,RING	4
DKBG	22 PAOZZ	4730-00-729-6437	82646	7412079	BOLT,FLUID PASSAGE	4
DCGW	23 PAOZZ	4710-01-492-2232	7J015	1054060	TUBE ASSEMBLY METALLIC	1
					END OF FIGURE	

GROUP 1311 WHEEL AND HUB ASSEMBLY

0072 00

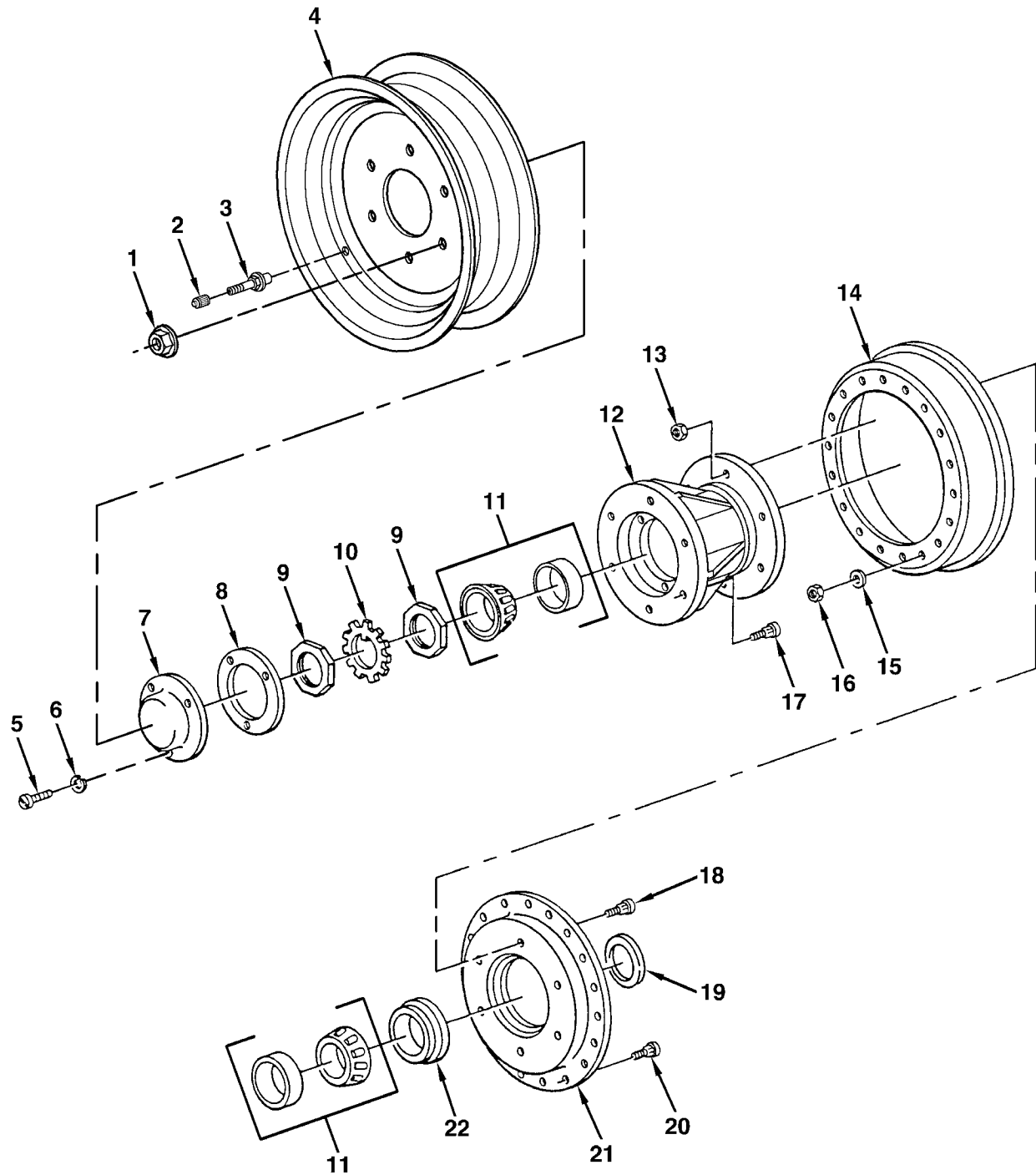

FIGURE 10. WHEEL AND HUB ASSEMBLY

GROUP 1311 WHEEL AND HUB ASSEMBLY REPAIR PARTS LIST - Continued

0072 00

(1) ITEM NO.	(2) SMR CODE	(3) NSN	(4) CAGEC	(5) PART NUMBER	(6) DESCRIPTION AND USABLE ON CODE (UOC)	(7) QTY
GROUP 1311 WHEEL ASSEMBLY						
FIG. 10 WHEEL AND HUB ASSEMBLY						
DJAEA	1 PAOZZ		7J015	1050116	NUT.....	12
DJAJ	2 PAOZZ	2640-01-492-2293	7J015	1050113	CAP.....	3
DJAN	3 PAOZZ	4820-01-492-2240	7J015	1050111	STEM.....	3
DJAS	4 PAOZZ	2530-01-492-2208	7J015	1050110	WHEEL.....	3
DJAW	5 PAOZZ	5305-00-988-1723	96906	MS35206-279	SCREW,MACHINE 1/4-20X1/2...	6
DJAY	6 PAOZZ	5310-00-582-5965	96906	MS35338-44	WASHER, LOCK 1/4.....	6
DJBE	7 PAOZZ	2530-01-492-9908	19207	10910884	CAP,HUB.....	2
DJBU	8 PAOZZ	5330-00-246-8223	19207	10910885	GASKET.....	2
DJDG	9 PAOZZ	5310-00-741-1379	19207	7411379	NUT,ADJUSTING 2 5/8-16.....	4
DJDA	10 PAOZZ	5310-00-741-1378	19207	7411378	WASHER,KEY 2 21/32.....	2
DJBJ	11 PAOZZ	3110-00-100-5951	81348	FFB187/01-490	BEARING,ROLLER TAPE.....	4
DJBA	12 PAOZZ	2530-00-677-0202	19207	8719915	HUB,WHEEL.....	2
DJBW	13 PAOZZ	5310-00-935-3569	96906	MS51943-46	NUT,SELF-LOCKING 3/4-16....	12
DJCE	14 PAOZZ	2530-00-741-1425	19207	8719913	BRAKEDRUM.....	2
DJCJ	15 PAOZZ	5310-00-080-6004	96906	MS27183-14	FLATWASHER 13/32.....	36
DJCU	16 PAOZZ	5310-00-655-9599	19207	8720024	NUT,SELF-LOCKING 5/8-24....	36
DJCW	17 PAOZZ	5306-00-383-4957	96906	MS51946-2	BOLT,RIBBED 3/4-16X2 15/32..	12
DJDE	18 PAOZZ	5306-00-206-1560	96906	MS51946-11	BOLT 2 3/4-16X1 7/16.....	12
DJDU	19 PAOZZ	5365-00-741-1433	19207	7411433	SLEEVE,SPACER.....	2
DJCN	20 PAOZZ	5306-00-335-4768	18876	8720025	BOLT,RIBBED 3/8-24X1 9/32..	36
DJCA	21 PAOZZ	2530-00-741-3231	19207	7413231	PLATE,ADAPTER.....	2
DJDN	22 PAOZZ	5330-00-741-1429	19207	7411429	SEAL,OIL.....	2
END OF FIGURE						

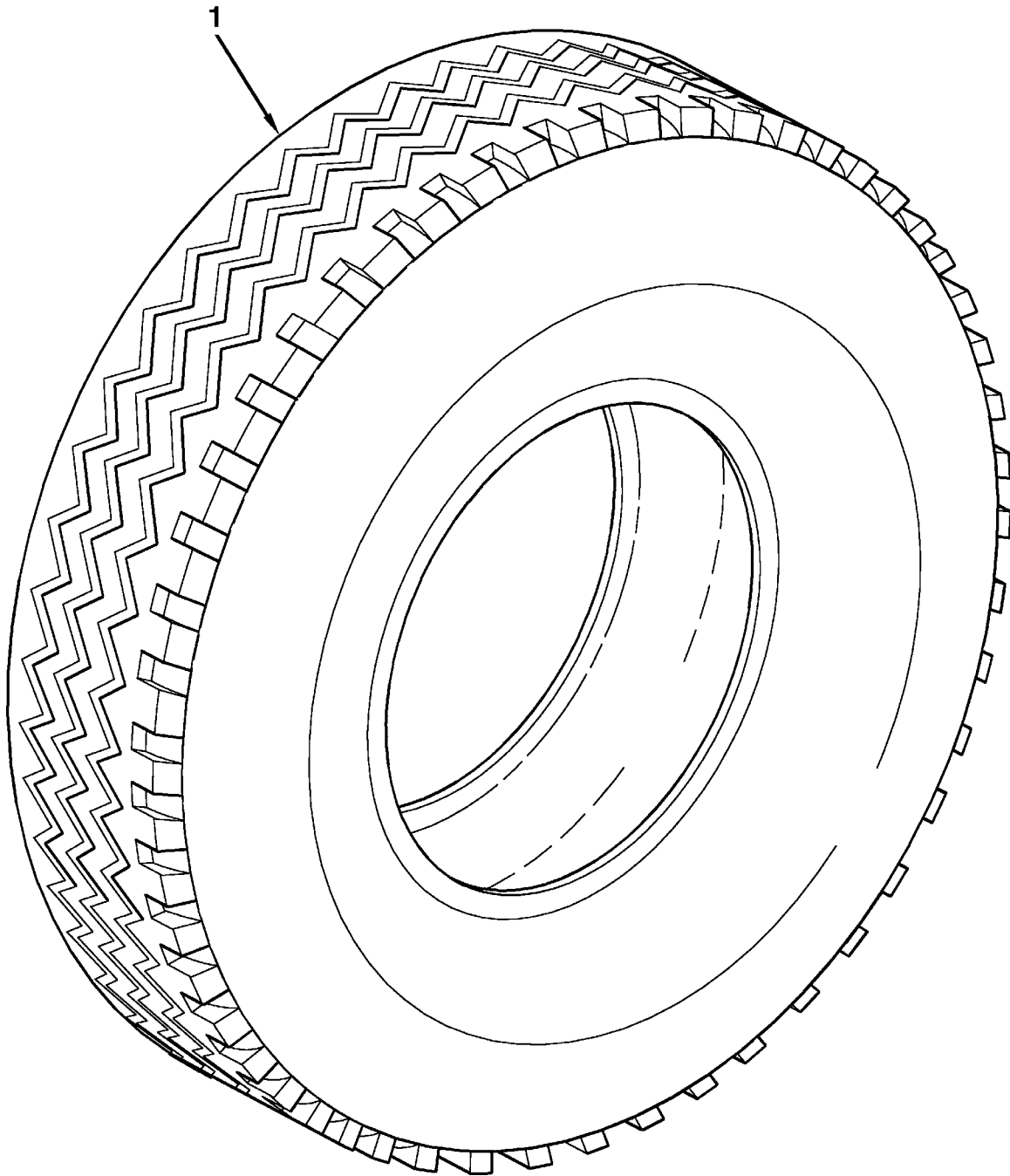

FIGURE 11. TIRE

GROUP 1313 TIRE AND TUBE REPAIR PARTS LIST - Continued

0073 00

(1) ITEM NO.	(2) SMR CODE	(3) NSN	(4) CAGEC	(5) PART NUMBER	(6) DESCRIPTION AND USABLE ON CODE (UOC)	(7) QTY
					GROUP 1313 TIRES	
					FIG. 11 TIRE	
DAEC	1 PAOZZ		5B707	138-769-895	TIRE,PNEUMATIC 10R22.5	3
					END OF FIGURE	

GROUP 1503 DRAWBAR RING AND SAFETY CHAIN

0074 00

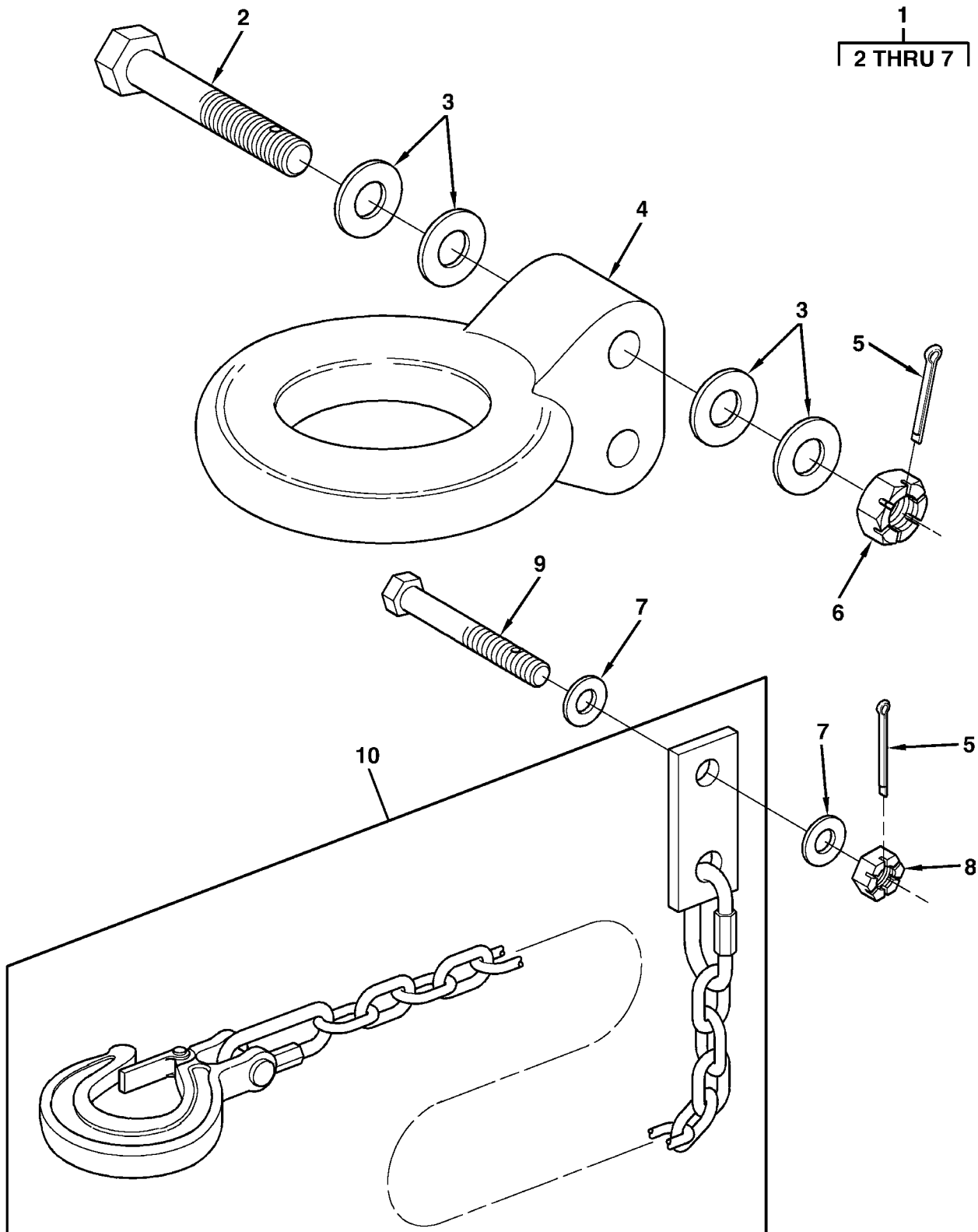

FIGURE 12. DRAWBAR RING AND SAFETY CHAIN

GROUP 1503 DRAWBAR RING AND SAFETY CHAIN REPAIR PARTS LIST - Continued **0074 00**

(1) ITEM NO.	(2) SMR CODE	(3) NSN	(4) CAGEC	(5) PART NUMBER	(6) DESCRIPTION AND USABLE ON CODE (UOC)	(7) QTY
					GROUP 1503 PINTLES AND TOWING ATTACHMENTS	
					FIG. 12 DRAWBAR RING AND SAFETY CHAIN	
DMAC	1	PA000		7J015 1054580	LUNETTE ASSEMBLY.....	1
DMAE	2	PAOZZ	5306-01-492-0929	7J015 1054600	SCREW.....	2
DMAJ	3	PAOZZ	5310-00-823-8803	96906 MS27183-21	FLATWASHER 21/32.....	10
DMAN	4	XAOZZ	2540-01-492-2243	7J015 1054585	COUPLER, DRAWBAR.....	1
DMAWA	5	PAOZZ	5315-00-013-7228	80205 MS24665-423	COTTER PIN 5/32X1 1/2.....	3
DMBAA	6	PAOZZ	5310-00-850-6876	96906 MS35692-49	NUT, SLOTTED 5/8-11.....	2
DMAR	7	PAOZZ	5310-00-809-8533	96906 MS27183-23	FLATWASHER 53/64.....	2
DMASA	8	PAOZZ	5310-00-850-6881	96906 MS35692-57	NUT, SLOTTED 3/4-10.....	1
DMBC	9	PAOZZ	5306-01-492-0980	7J015 1054610-2	BOLT.....	1
DMBEA	10	PAOZZ		7J015 1054620	SAFETY CHAIN ASSEMBLY.....	2
					END OF FIGURE	

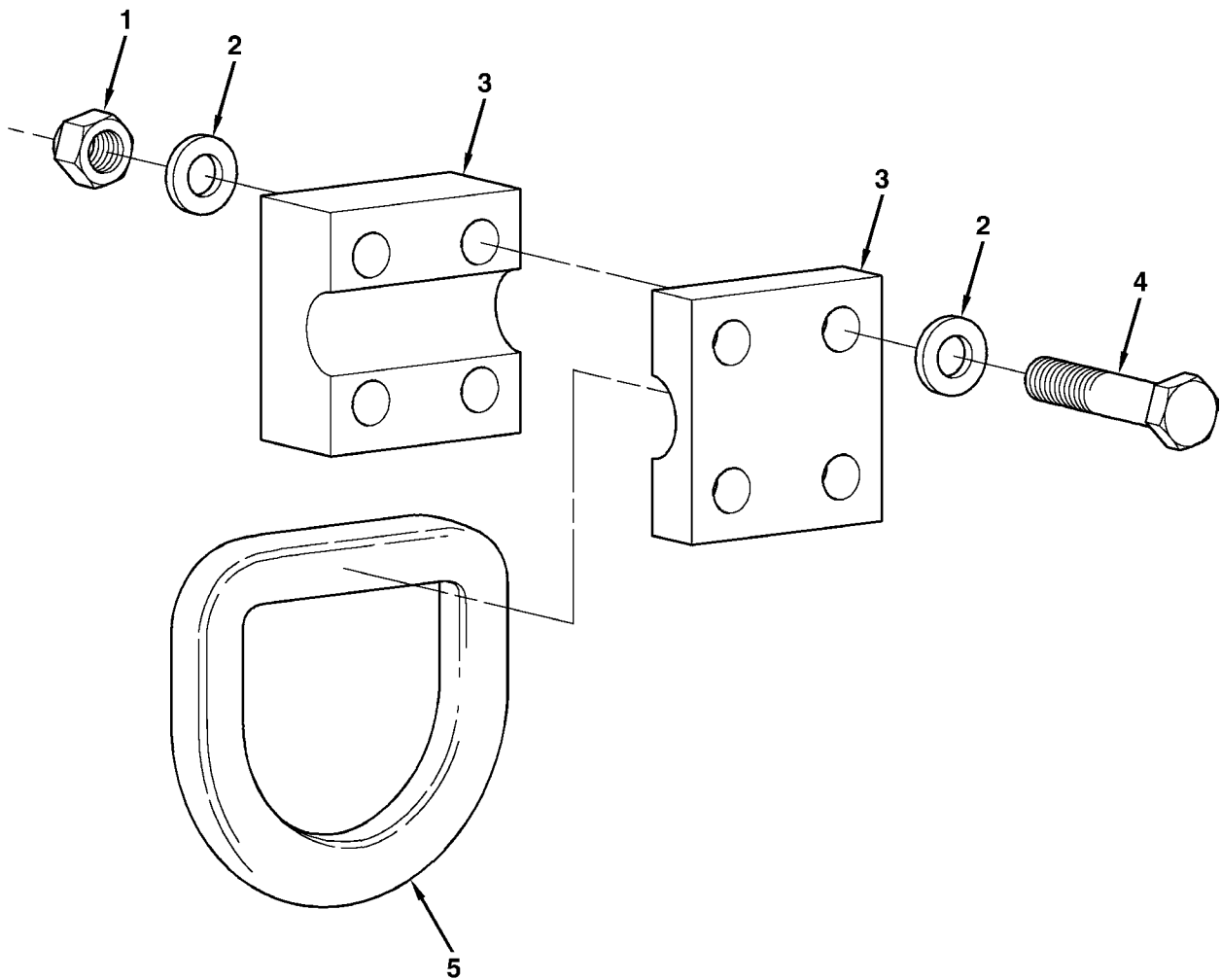

FIGURE 13. D-RINGS

GROUP 1503 D-RINGS REPAIR PARTS LIST - Continued

0075 00

(1) ITEM NO.	(2) SMR CODE	(3) NSN	(4) CAGEC	(5) PART NUMBER	(6) DESCRIPTION AND USABLE ON CODE (UOC)	(7) QTY
					GROUP 1503 PINTLES AND TOWING ATTACHMENTS	
					FIG. 13 D-RINGS	
DAEL	1 PAOZZ	5310-00-225-6993	81349	M45913/1-8CG5C	NUT, SELF-LOCKING 1/2-13....	16
DAEM	2 PAOZZ	5310-00-809-5997	96906	MS27183-17	FLATWASHER 1/2.....	32
DACN	3 PAOZZ	5340-01-487-5091	7J015	1050050	D-RING BLOCK.....	4
DAEK	4 PAOZZ	5305-00-071-2077	80204	B1821BH050C350N	SCREW, CAP, HEXAGON 1/2-13X3 1/2 GR 8.....	16
DACU	5 PAOZZ	5365-01-487-5358	7J015	1050060	D-RING.....	4
					END OF FIGURE	

GROUP 1507 LANDING GEAR

0076 00

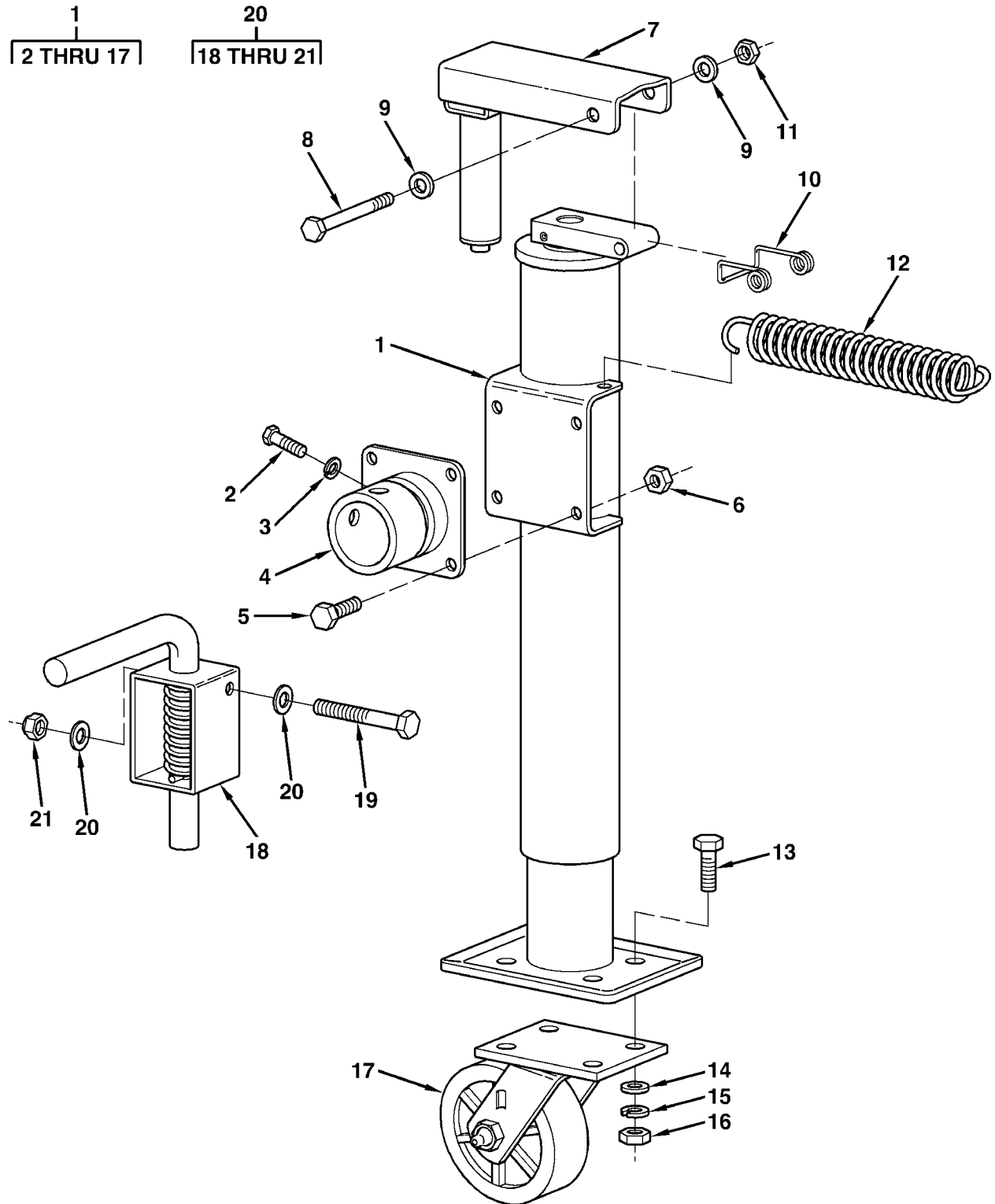

FIGURE 14. LANDING GEAR

GROUP 1507 LANDING GEAR REPAIR PARTS LIST - Continued

0076 00

(1) ITEM NO.	(2) SMR CODE	(3) NSN	(4) CAGEC	(5) PART NUMBER	(6) DESCRIPTION AND USABLE ON CODE (UOC)	(7) QTY
GROUP 1507 LANDING GEAR, LEVELING JACKS						
FIG. 14 LANDING GEAR						
DGAA	1 PA000	2590-01-487-5447	7J015	1052000	LANDING GEAR	1
DGAS	2 PAOZZ	5305-00-068-7837	80204	B1821BH025C063N	SCREW,CAP,HEXAGON 1/4-20X5/8	1
DGAWA	3 PAOZZ	5310-00-012-1637	96906	MS35338-25	WASHER,LOCK 17/64	1
DGAY	4 PAOZZ		7J015	1052013	PLATE	1
DGAZ	5 PAOZZ	5305-00-068-0508	80204	B1821BH025C075N	SCREW,CAP,HEXAGON 1/4-20X3/4 GR 8	4
DGBC	6 PAOZZ	5310-00-088-1251	81349	M45913/1-4CG5C	NUT,SELF-LOCKING 1/4-20 ...	4
DGBEA	7 PA000		7J015	1052001	HANDLE ASSEMBLY	1
DGBG	8 PAOZZ	5305-00-071-2236	80205	MS90725-15	BOLT 1/4-20X2 1/4	2
DGBL	9 PAOZZ	5310-00-823-8804	96906	MS27183-9	FLATWASHER	2
DGBQ	10 PAOZZ		7J015	1052130	HANDLE SPRING 1/4	1
DGBU	11 PAOZZ	5310-00-088-1251	81349	M45913/1-4CG5C	NUT,SELF-LOCKING 1/4-20 ...	1
DGBA	12 PAOZZ	5360-01-492-0948	7J015	1052195	SPRING	1
DGBF	13 PAOZZ	5305-00-269-3213	80205	MS90725-62	SCREW,CAP,HEXAGON 3/8-16X1 1/4	4
DGBJ	14 PAOZZ	5310-01-280-5796	96906	MS27183-57	FLATWASHER 13/32	4
DGBN	15 PAOZZ	5310-00-637-9541	96906	MS35338-46	WASHER,LOCK 25/64	4
DGBS	16 PAOZZ	5310-00-732-0558	96906	MS51967-8	NUT,PLAIN HEXAGON 3/8-16 ..	4
DGBW	17 PAOZZ	5340-01-492-0955	7J015	1052190	POLYOLEFIN CASTER	1
DGAU	18 PAOZZ	2590-01-492-2252	7J015	1051300	FRONT LATCH ASSEMBLY	1
DGCN	19 PAOZZ	5305-00-071-2236	80205	MS90725-15	SCREW,CAP,HEXAGON 1/4-20X2 1/4	1
DGCE	20 PAOZZ	5310-00-809-4058	96906	MS27183-10	FLATWASHER 9/32	2
DGCA	21 PAOZZ	5310-00-061-4650	96906	MS51943-31	NUT,SELF-LOCKING 1/4-20 ...	1
END OF FIGURE						

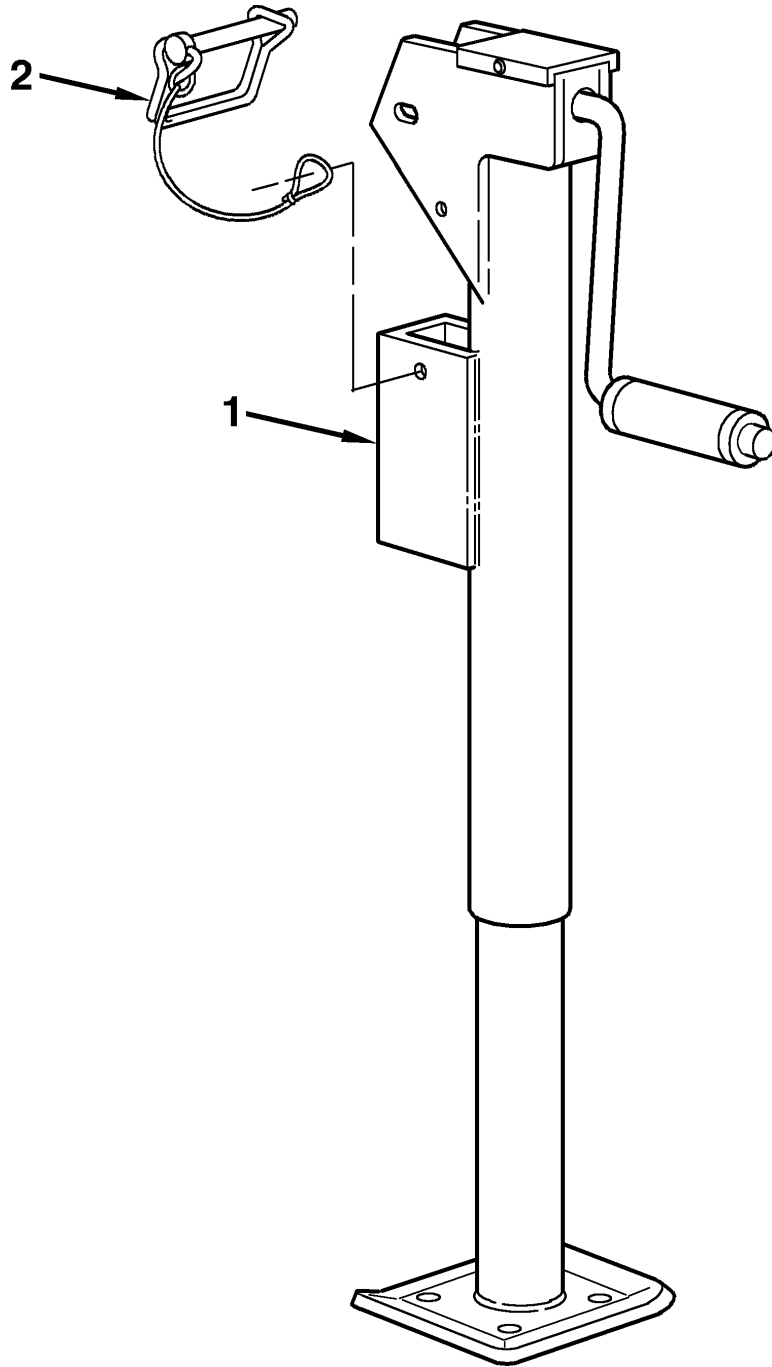

FIGURE 15. STABILIZER

GROUP 1507 LANDING GEAR REPAIR PARTS LIST - Continued

0077 00

(1) ITEM NO.	(2) SMR CODE	(3) NSN	(4) CAGEC	(5) PART NUMBER	(6) DESCRIPTION AND USABLE ON CODE (UOC)	(7) QTY
					GROUP 1507 LANDING GEAR, LEVELING JACKS	
					FIG. 15 STABILIZER	
DHAA	1 PAOZZ		7J015	1052200	STABILIZER.....	1
DHAE	2 PAOZZ		7J015	1052380	LOCKPIN ASSEMBLY.....	1
					END OF FIGURE	

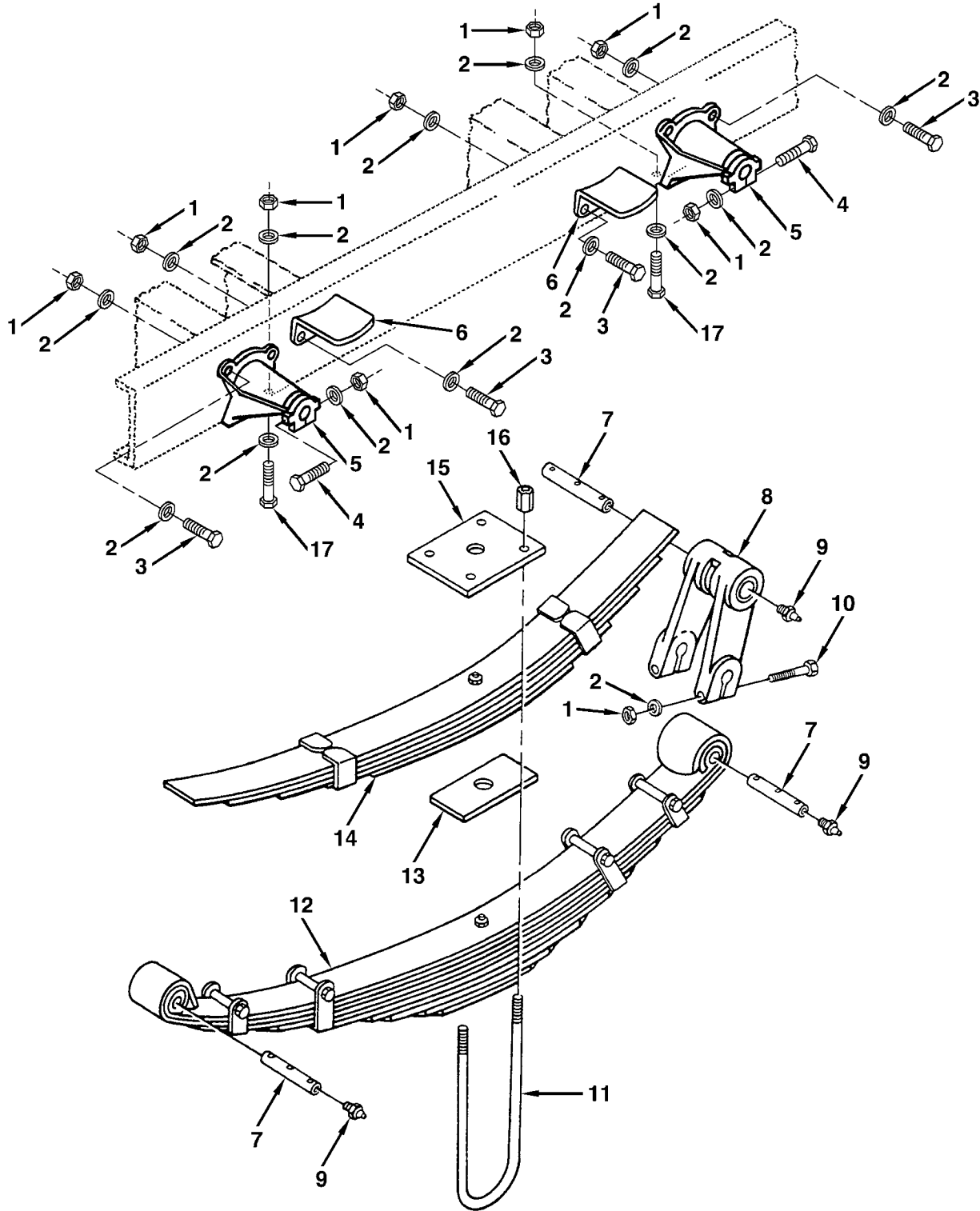

FIGURE 16. MAIN AND AUXILIARY SPRINGS

GROUP 1601 MAIN AND AUXILIARY SPRINGS REPAIR PARTS LIST - Continued

0078 00

(1) ITEM NO.	(2) SMR CODE	(3) NSN	(4) CAGEC	(5) PART NUMBER	(6) DESCRIPTION AND USABLE ON CODE (UOC)	(7) QTY
					GROUP 1601 SPRINGS AND SHOCK ABSORBERS	
					FIG. 16 MAIN AND AUXILIARY SPRINGS	
DADW	1 PAOZZ	5310-00-087-4652	96906	MS51922-17	NUT, SELF-LOCKING 3/8-16	36
DAEA	2 PAOZZ	5310-00-080-6004	96906	MS27183-14	FLATWASHER 13/32	64
DAEEA	3 PAOZZ	5305-00-725-2317	80204	B1821BH038C150N	SCREW, CAP, HEXAGON 3/8-16X1 1/2	24
DAEJA	4 PAOZZ	5305-00-846-5703	80204	B1821BH038C300N	SCREW, CAP, HEXAGON H 3/8-16X3	4
DAAN	5 PFOZZ	2510-01-194-9890	19207	7979525	HANGER, SPRING, VEHIC	4
DAENA	6 PFOZZ	2590-01-376-8844	19207	7979519	BRACKET	4
DABA	7 PAOZZ	2510-00-752-1826	23705	296243	PIN, VEHICULAR LEAF	6
DAAU	8 PAOZZ	2510-00-752-1841	56442	348S3	SHACKLE, LEAF SPRING ASSY . . .	2
DAES	9 PAOZZ	4730-00-050-4203	96906	MS15001-1	FITTING, LUBRICATION	6
DAEW	10 PAOZZ	5305-00-846-5703	80204	B1821BH038C300N	SCREW, CAP, HEXAGON 3/8-16X3 .	4
DACG	11 PAOZZ	5306-00-174-4311	19207	8327047	BOLT, U	4
DABG	12 PAOZZ	2510-00-736-8628	78500	5RE72E	SPRING ASSEMBLY, LEAF MAIN . .	2
DACA	13 XDOZZ	5340-01-392-8919	19207	7979574	PLATE	2
DABN	14 PAOZZ	2510-00-741-1042	19207	7411042	SPRING ASSEMBLY, LEAF AUXILIARY	2
DABU	15 XDOZZ	5340-01-393-8017	19207	7979573	PLATE	2
DAFA	16 PAOZZ	5310-00-832-9719	96906	MS51922-61	NUT, SELF-LOCKING 3/4-16	8
DAFE	17 PAOZZ	5305-00-821-3869	80204	B1821BH038C175N	SCREW, CAP HEXAGON 3/8-16X1 3/4	4
					END OF FIGURE	

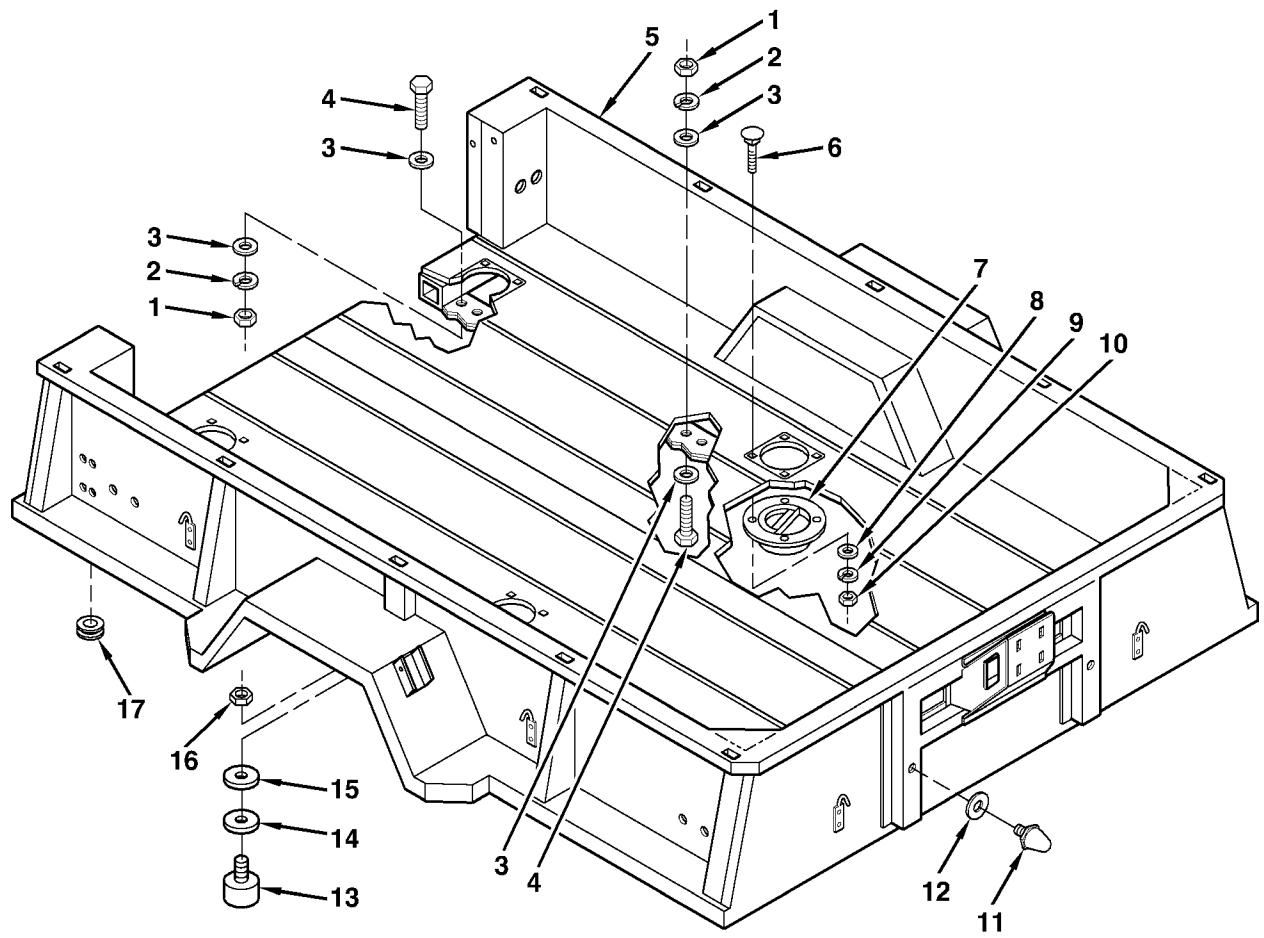

FIGURE 17. CARGO BODY

GROUP 1810 CARGO BODY REPAIR PARTS LIST - Continued

0079 00

(1) ITEM NO.	(2) SMR CODE	(3) NSN	(4) CAGEC	(5) PART NUMBER	(6) DESCRIPTION AND USABLE ON CODE (UOC)	(7) QTY
					GROUP 1810 CARGO BODY	
					FIG. 17 CARGO BODY	
DFCA	1 PAOZZ	5310-00-763-8920	96906	MS51967-20	NUT,PLAIN,HEXAGON 5/8-11 ...	12
DFCC	2 PAOZZ	5310-00-012-0898	96906	MS35338-30	WASHER,LOCK 37/64	12
DFCJ	3 PAOZZ	5831-00-823-8803	96906	MS27183-21	FLATWASHER 21/32	24
DFCG	4 PAOZZ		80204	B1821BH062C200N	SCREW,CAP,HEXAGON 5/8-11X2 GR 8	12
DFAA	5 XDOZZ		7J015	1058000	CARGO BODY	1
DFCL	6 PAOZZ		7J015	1058480	CARRIAGE BOLT 5/16-18X1 GR 5	24
DFCW	7 PAOZZ	3995-01-492-0957	7J015	1058395	CARGO TIE DOWN	6
DFDA	8 PAOZZ	5310-00-809-3078	96906	MS27183-11	FLATWASHER 5/16	24
DFDE	9 PAOZZ	5310-00-407-9566	96906	MS35338-45	WASHER,LOCK 5/16	24
DFDJ	10 PAOZZ	5310-00-880-7744	96906	MS51967-5	NUT,PLAIN,HEXAGON 5/16-18.	24
DFCX	11 PAOZZ		7J015	1058500	BUMPER	2
DFCZ	12 PAOZZ		7J015	1058510	FLATWASHER	2
DFCY	13 PAOZZ		7J015	1058038	JOUNCE STOP	2
DFDB	14 PAOZZ		7J015	1058037	SPACER	4
DFDD	15 PAOZZ	5310-00-080-6004	96906	MS27183-14	FLATWASHER 3/8	2
DFDF	16 PAOZZ	5310-00-732-0558	96906	MS51967-8	JAM NUT 3/8-16	2
DFDG	17 PAOZZ		7J015	1058520	GROMMET	2
					END OF FIGURE	

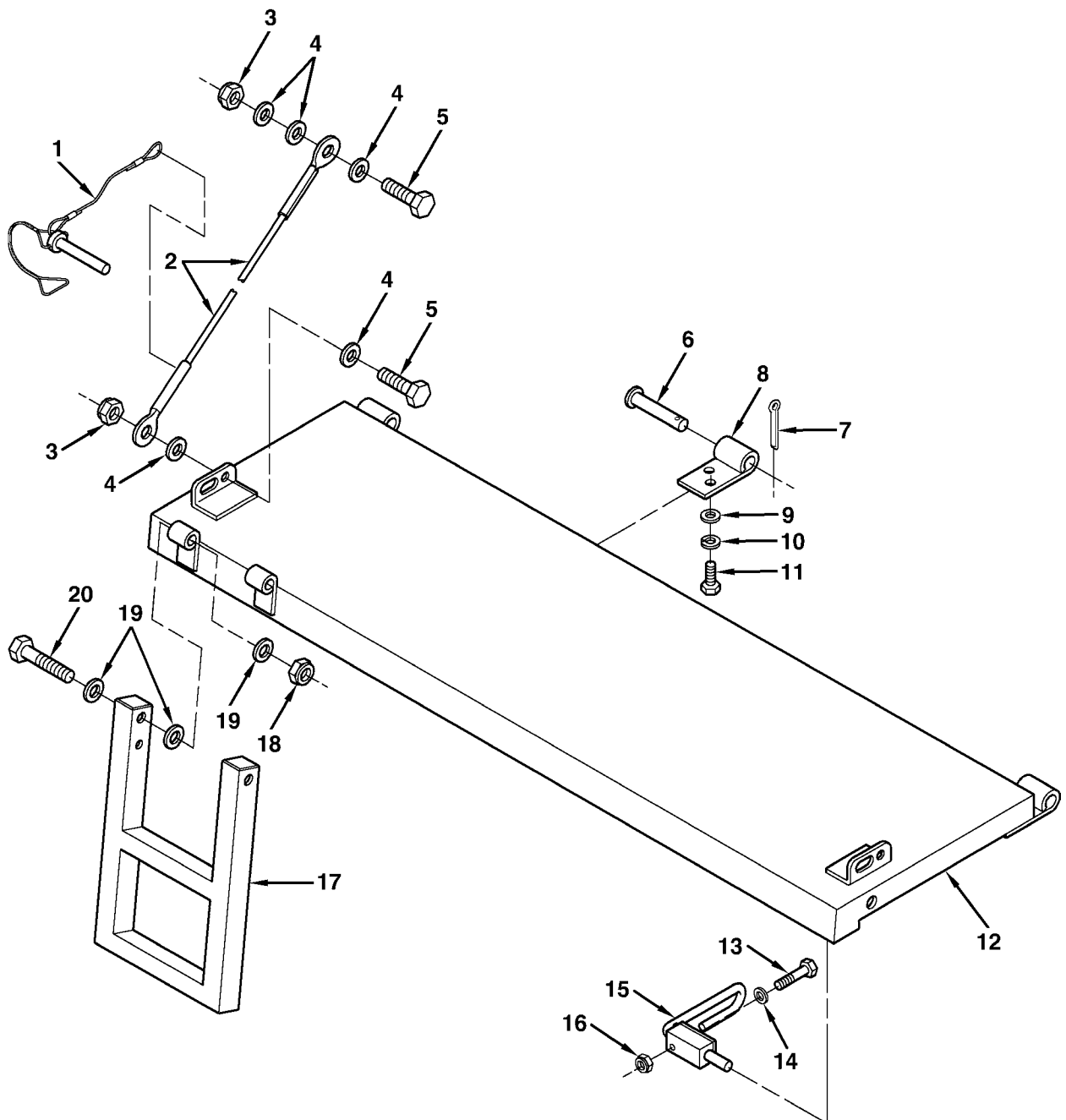

FIGURE 18. TAILGATE

GROUP 1810 TAILGATE REPAIR PARTS LIST - Continued

0080 00

(1) ITEM NO.	(2) SMR CODE	(3) NSN	(4) CAGEC	(5) PART NUMBER	(6) DESCRIPTION AND USABLE ON CODE (UOC)	(7) QTY
GROUP 1810 CARGO BODY						
FIG. 18 TAILGATE						
DFDNA	1 PAOZZ	5315-01-492-0969	7J015	1058287	LOCKPIN.....	1
DFDS	2 PAOZZ	4010-01-492-2165	7J015	1058282	LANYARD.....	2
DFDW	3 PAOZZ	5310-00-088-1251	81349	M45913/1-4CG5C	NUT,SELF-LOCKING 1/4-20....	4
DFEA	4 PAOZZ	5310-01-274-3255	96906	MS27183-52	FLATWASHER 9/32.....	10
DFEE	5 PAOZZ	5305-00-068-0502	96906	MS90725-6	SCREW,CAP,HEXAGON 1/4-20X3/4.....	4
DFEJ	6 PAOZZ	5315-00-904-1636	96906	MS20392-7C105	PIN,STRAIGHT HEADED 1/2X3 9/32.....	4
DFEN	7 PAOZZ	5315-00-236-8368	80205	MS24665-436	PIN,COTTER 5/32X3/4.....	4
DFDQ	8 PAOZZ		7J015	1058295-1	HINGE.....	2
DFDU	9 PAOZZ	5310-00-081-4219	96906	MS27183-12	FLATWASHER 5/16.....	4
DFDY	10 PAOZZ	5310-00-012-0214	96906	MS35338-26	WASHER,LOCK 5/16.....	4
DFEC	11 PAOZZ	5306-00-225-8496	96906	MS90725-31	SCREW,CAP HEX HEAD 5/16- 18X5/8 GR.5.....	4
DFAN	12 PAOZZ	2510-01-487-5442	7J015	1058230	TAILGATE.....	1
DFEG	13 PAOZZ	5305-00-068-0509	96906	MS90725-10	BOLT,MACHINE 1/4-18X1 1/4..	2
DFEL	14 PAOZZ	5310-00-809-4058	96906	MS27183-10	FLATWASHER 5/8.....	4
DFEQ	15 PAOZZ		7J015	1058290-1	LATCH ASSEMBLY, RIGHT.....	1
DFER	15 PAOZZ		7J015	1058290-2	LATCH ASSEMBLY, LEFT.....	1
DFEU	16 PAOZZ	5310-00-061-4650	96906	MS51943-31	NUT,SELF-LOCKING 1/4.....	2
DFES	17 PAOZZ	2541-01-492-2255	7J015	1058235	LADDER.....	1
DFEW	18 PAOZZ	5310-00-008-7843	81349	M45913/1-8CBB	NUT,SELF-LOCKING 1/2-13....	2
DFFA	19 PAOZZ	5310-00-809-5998	96906	MS27183-18	FLATWASHER 17/32.....	6
DFFEA	20 PAOZZ	5305-00-071-1772	80205	MS90725-119	SCREW,CAP,HEXAGON 1/2-13X3.	2
END OF FIGURE						

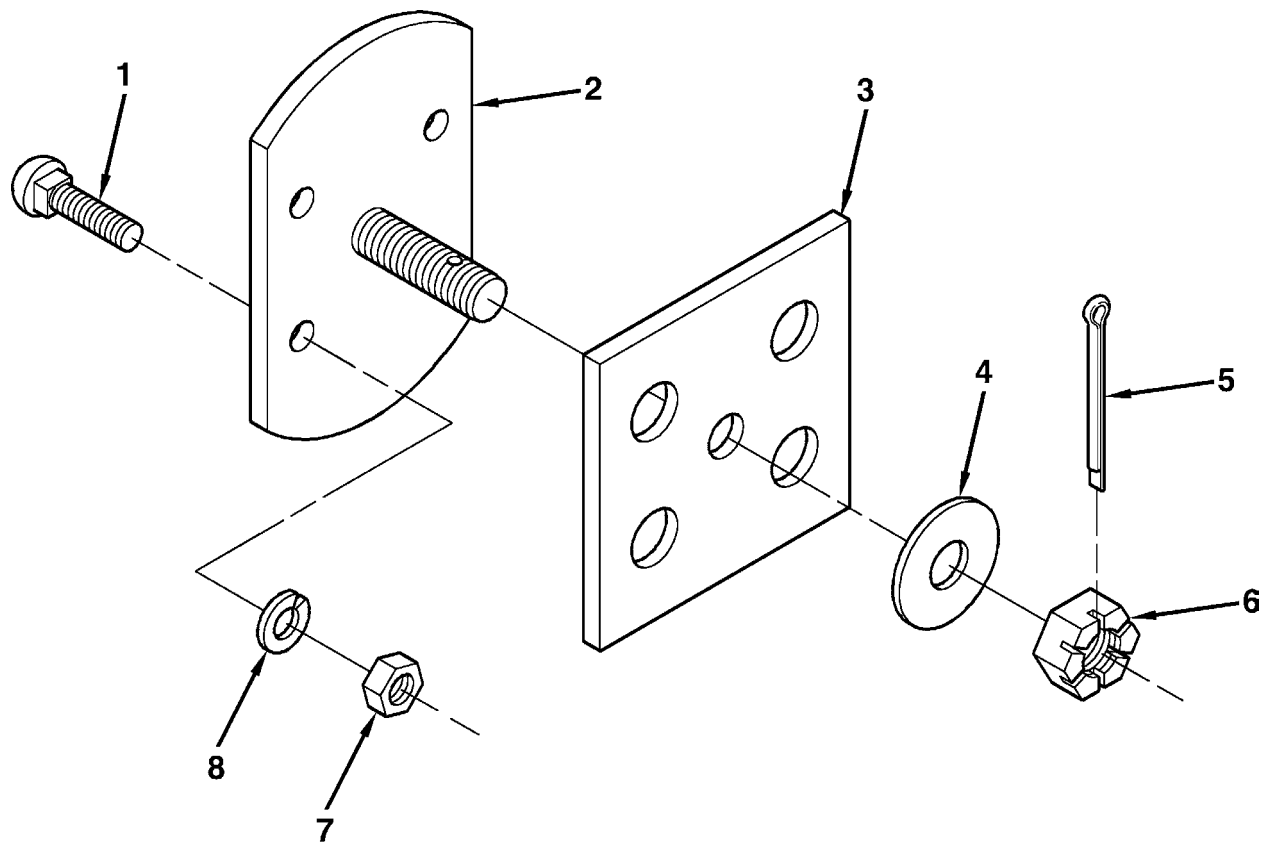

FIGURE 19. SPARE WHEEL RACK

GROUP 1810 SPARE WHEEL RACK REPAIR PARTS LIST - Continued

0081 00

(1) ITEM NO.	(2) SMR CODE	(3) NSN	(4) CAGEC	(5) PART NUMBER	(6) DESCRIPTION AND USABLE ON CODE (UOC)	(7) QTY
					GROUP 1810 CARGO BODY	
					FIG. 19 SPARE WHEEL HUB	
DFFJ	1	PAOZZ		7J015 1058480	CARRIAGE BOLT 5/16-18X1 GR 5.....	4
DFFN	2	PAOZZ	3040-01-492-2258	7J015 1058460	HUB SUPPORT.....	1
DFFS	3	PAOZZ	5340-01-492-0973	7J015 1058470	RETAINER PLATE.....	1
DFFW	4	PAOZZ	5310-00-809-8533	96906 MS27183-23	FLATWASHER 13/16.....	1
DFGAA	5	PAOZZ	5315-00-013-7228	80205 MS24665-423	PIN,COTTER 5/32X1 1/2.....	1
DFGE	6	PAOZZ	5310-00-850-6881	96906 MS35692-57	NUT,PLAIN,SLOTTED,HEXAGON 3/4-10.....	1
DFGJ	7	PAOZZ	5310-00-984-3806	81349 M45913/1-5CG5C	NUT,SELF-LOCKING 5/16-18...	4
DFGN	8	PAOZZ	5310-00-407-9566	96906 MS35338-45	WASHER,LOCK 5/16.....	4
					END OF FIGURE	

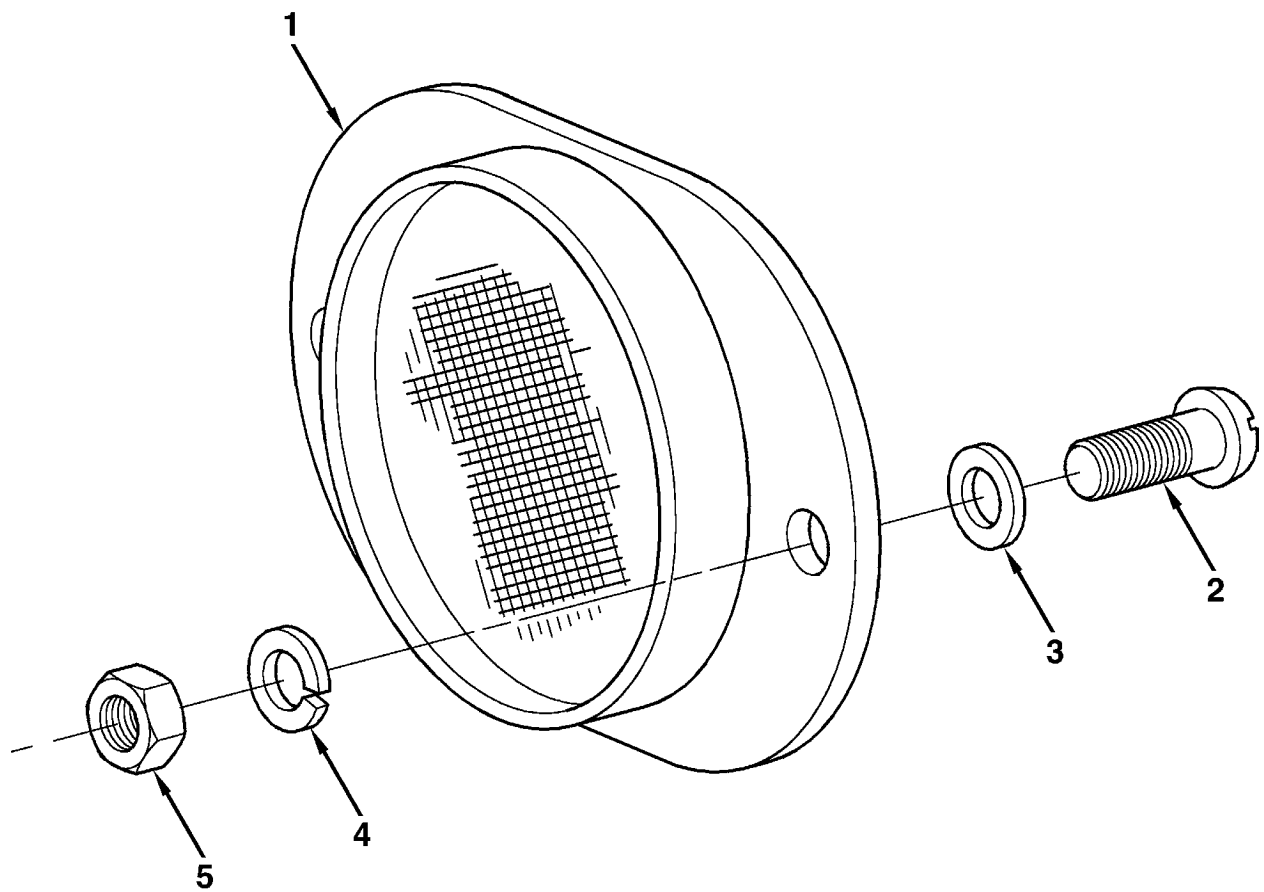

FIGURE 20. REFLECTORS

GROUP 2202 REFLECTORS REPAIR PARTS LIST - Continued

0082 00

(1) ITEM NO.	(2) SMR CODE	(3) NSN	(4) CAGEC	(5) PART NUMBER	(6) DESCRIPTION AND USABLE ON CODE (UOC)	(7) QTY
					GROUP 2202 ACCESSORY ITEMS	
					FIG. 20 REFLECTORS	
DFAU	1 PAOZZ	9905-00-205-2795	19207	6161059A	REFLECTOR,INDICATING RED ...	4
DFBA	1 PAOZZ	9905-00-202-3639	96906	MS35387-2	REFLECTOR,INDICATING AMBER .	2
DFGS	2 PAOZZ	5305-00-988-1723	96906	MS35206-279	SCREW,MACHINE 1/4-20X1/2 ...	12
DFGW	3 PAOZZ	5310-01-274-3255	96906	MS27183-52	FLATWASHER 9/32	12
DFHA	4 PAOZZ	5310-00-582-5965	96906	MS35338-44	WASHER,LOCK 1/4	12
DFHE	5 PAOZZ	5310-00-761-6882	96906	MS51967-2	NUT,PLAIN,HEXAGON 1/4-20 ...	12
					END OF FIGURE	

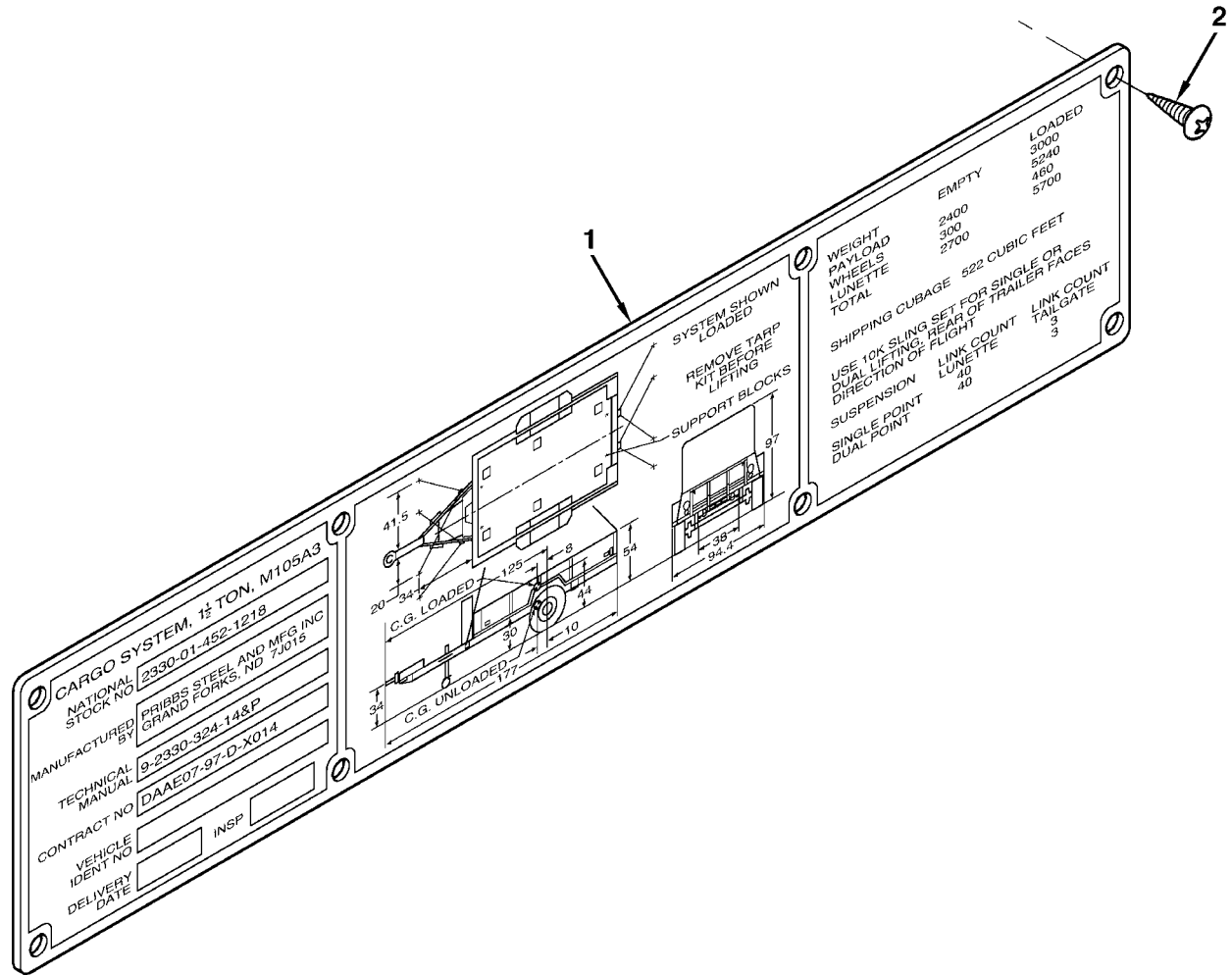

FIGURE 21. DATA PLATES

GROUP 2210 DATA PLATES REPAIR PARTS LIST - Continued

0083 00

(1) ITEM NO.	(2) SMR CODE	(3) NSN	(4) CAGEC	(5) PART NUMBER	(6) DESCRIPTION AND USABLE ON CODE (UOC)	(7) QTY
					GROUP 2210 ACCESSORY ITEMS	
					FIG. 21 DATA PLATES	
DADA	1 PAOZZ	5330-01-272-7367	7J015	1050070	PLATE,TRANSPORTATION.....	1
DADD	2 PAOZZ		96906	MS20604S4T5	RIVET,BLIND 1/8X.251-.312..	8
					END OF FIGURE	

NATIONAL STOCK NUMBER INDEX

0084 00

STOCK NUMBER	FIG.	ITEM	STOCK NUMBER	FIG.	ITEM
5310-00-008-7843	18	18	2530-00-159-8756	6	20
5310-00-012-0214	18	10	5306-00-174-4311	16	11
5310-00-012-0898	17	2	6220-00-179-4324	1	12
5310-00-012-1637	14	3	9905-00-202-3639	20	1
5315-00-013-7228	7	17	9905-00-205-2795	20	1
	12	5	5306-00-206-1560	10	18
	19	5	5310-00-209-5116	6	9
6240-00-019-0877	2	5	5310-00-225-6993	13	1
6240-00-019-3093	1	8	5306-00-225-8496	7	15
5310-00-043-2226	2	7		18	11
5310-00-045-3296	3	11	5306-00-225-8499	5	5
	9	4	5940-00-230-0515	3	17
4730-00-050-4203	16	9	5315-00-236-8368	18	7
5305-00-052-9051	7	11	5305-00-240-0194	2	6
5340-00-057-2904	3	10		3	9
	9	3		9	2
5999-00-057-2929	3	8	5330-00-246-8223	10	8
	3	24	5310-00-261-7340	8	3
5310-00-061-4650	14	21	5305-00-269-2804	6	22
	18	16	5305-00-269-3213	14	13
5305-00-068-0502	18	5	5305-00-269-3241	6	25
5305-00-068-0508	14	5	5365-00-274-4544	9	21
5305-00-068-0509	18	13	5310-00-274-8715	5	26
5305-00-068-0515	6	26	6220-00-299-7426	2	3
5305-00-068-7837	14	2	5310-00-314-0764	6	4
5305-00-071-1772	18	20	5310-00-314-0765	6	3
5305-00-071-2077	13	4	5310-00-322-7260	6	2
5305-00-071-2236	14	8	5315-00-322-7261	6	6
	14	19	5306-00-335-4768	10	20
3040-00-074-2357	6	7	5306-00-383-4957	10	17
5310-00-080-6004	5	18	5940-00-399-6676	3	4
	10	15		3	21
	16	2	5310-00-407-9566	5	7
	17	15		7	8
5310-00-081-4219	5	3		7	16
	7	7		17	9
	18	9		19	8
5310-00-087-4652	16	1	4730-00-419-9425	9	16
5310-00-088-1251	14	6	2530-00-441-0210	5	24
	14	11	5331-00-462-0907	1	3
	18	3	2530-00-522-1157	6	21
3110-00-100-5951	10	11	5310-00-543-2705	5	22
5305-00-115-9526	1	10	5305-00-543-2866	5	17
	8	4	4710-00-566-7133	9	17
3040-00-150-7127	6	7	4710-00-566-7134	9	19
2530-00-159-8755	6	20	5835-00-572-9180	3	22

NATIONAL STOCK NUMBER INDEX

0084 00

STOCK NUMBER	FIG.	ITEM	STOCK NUMBER	FIG.	ITEM
5935-00-572-9180	3	6	5310-00-761-6882	5	27
5310-00-582-5965	5	21		9	14
	6	16		20	5
	9	13	5310-00-763-8920	17	1
	10	6	5305-00-770-9149	6	23
	20	4	2530-00-770-9150	6	24
5310-00-596-7691	2	9	2530-00-770-9151	6	24
5310-00-619-4848	5	19	2530-00-794-9763	6	21
5310-00-627-6128	6	15	5310-00-809-3078	5	6
4710-00-630-9928	9	19		17	8
5310-00-637-9541	1	9	5310-00-809-4058	14	20
	14	15		18	14
5310-00-641-9939	6	18	5310-00-809-5997	13	2
5310-00-655-9599	10	16	5310-00-809-5998	18	19
2530-00-677-0202	10	12	5310-00-809-8533	7	2
2530-00-693-1007	6	8		12	7
5360-00-699-9018	6	1		19	4
5305-00-725-2317	16	3	5305-00-821-3869	16	17
6220-00-726-1916	2	1	5310-00-823-8803	12	3
4730-00-729-6437	9	22		17	3
6220-00-729-9295	2	2	5310-00-823-8804	14	9
5310-00-732-0558	5	23	5315-00-825-8353	5	13
	14	16	5310-00-832-9719	16	16
	17	16	5935-00-833-8561	3	2
5310-00-732-0559	5	11		3	19
	6	14	5970-00-833-8562	3	3
2510-00-736-8628	16	12		3	20
2530-00-737-3260	8	2	5310-00-833-8567	3	7
2510-00-741-1042	16	14		3	23
5310-00-741-1378	10	10	5305-00-846-5703	16	4
5310-00-741-1379	10	9		16	10
2530-00-741-1425	10	14	5310-00-850-6876	12	6
5330-00-741-1429	10	22	5310-00-850-6881	7	18
5365-00-741-1433	10	19		12	8
5306-00-741-1760	6	13		19	6
4730-00-741-1903	9	18	5310-00-880-7744	5	8
4710-00-741-1907	9	17		17	10
2530-00-741-2050	6	12	5310-00-903-3993	6	10
2530-00-741-2065	8	1	5315-00-903-5943	5	4
2530-00-741-2068	6	12	5315-00-904-1636	18	6
5310-00-741-2088	9	20	5310-00-924-4218	6	17
5365-00-741-2103	6	19	5310-00-934-9758	2	8
2530-00-741-3231	10	21		3	12
2510-00-752-1826	16	7		9	5
2510-00-752-1841	16	8	5310-00-935-3569	10	13
5310-00-761-6882	5	20	2530-00-973-2355	6	5

NATIONAL STOCK NUMBER INDEX

0084 00

STOCK NUMBER	FIG.	ITEM	STOCK NUMBER	FIG.	ITEM
2530-00-973-2356	6	5	5340-01-492-0973	19	3
5310-00-984-3806	19	7	5306-01-492-0980	7	1
5305-00-984-6214	2	4		12	9
5342-00-987-2565	5	25	6150-01-492-2003	3	15
5305-00-988-1723	10	5	6150-01-492-2004	3	18
	20	2	6150-01-492-2005	3	25
5342-00-991-4342	5	25	6150-01-492-2006	3	26
6220-01-067-4717	1	4	4010-01-492-2165	18	2
2530-01-083-5641	6	11	2530-01-492-2208	10	4
6220-01-093-4439	1	1	2350-01-492-2215	7	3
5845-01-168-0148	3	1	4710-01-492-2219	9	7
3040-01-169-7388	5	1	4735-01-492-2221	9	8
2510-01-194-9890	16	5	4710-01-492-2225	9	9
5330-01-272-7367	21	1	4730-01-492-2227	9	12
5310-01-274-3255	18	4	4710-01-492-2229	9	15
	20	3	4710-01-492-2232	9	23
5310-01-280-5796	14	14	4820-01-492-2240	10	3
6220-01-284-2709	1	6	2540-01-492-2243	12	4
6220-01-297-3217	1	5	2590-01-492-2252	14	18
5306-01-303-2815	5	15	2541-01-492-2255	18	17
5315-01-359-1451	5	2	3040-01-492-2258	19	2
	5	14	2640-01-492-2293	10	2
5306-01-362-2851	7	9	2530-01-492-9908	10	7
2590-01-376-8844	16	6			
5340-01-392-8919	16	13			
5340-01-393-8017	16	15			
6240-01-447-3779	1	7			
5340-01-487-5091	3	14			
	13	3			
3040-01-487-5119	5	28			
5365-01-487-5358	13	5			
	5	12			
2510-01-487-5442	18	12			
2590-01-487-5447	14	1			
5306-01-487-5691	5	10			
5340-01-487-5752	5	9			
5340-01-492-0907	5	16			
5340-01-492-0911	7	12			
5340-01-492-0912	9	6			
5340-01-492-0919	9	10			
5340-01-492-0922	9	11			
5306-01-492-0929	12	2			
5360-01-492-0948	14	12			
5340-01-492-0955	14	17			
3995-01-492-0957	17	7			
5315-01-492-0969	18	1			

TM 9-2330-324-14&P

PART NUMBER INDEX

0085 00

CAGEC	PN	NSN	FIG	ITEM
92867	02183400	3040-01-169-7388	5	1
7J015	1050050	5340-01-487-5091	13	3
7J015	1050060	5365-01-487-5358	13	5
7J015	1050070	5330-01-272-7367	21	1
7J015	1050110	2530-01-492-2208	10	4
7J015	1050111	4820-01-492-2240	10	3
7J015	1050113	2640-01-492-2293	10	2
7J015	1050116		10	1
7J015	1051300	2590-01-492-2252	14	18
7J015	1052000	2590-01-487-5447	14	1
7J015	1052001		14	7
7J015	1052013		14	4
7J015	1052130		14	10
7J015	1052190	5340-01-492-0955	14	17
7J015	1052195	5360-01-492-0948	14	12
7J015	1052200		15	1
7J015	1052380		15	2
7J015	1053010	3040-01-487-5119	5	28
7J015	1053070	5340-01-487-5368	5	12
7J015	1053075	5340-01-487-5752	5	9
7J015	1053080	5306-01-487-5691	5	10
7J015	1053095	5340-01-492-0907	5	16
7J015	1054010		9	1
7J015	1054020	5340-01-492-0912	9	6
7J015	1054030	4710-01-492-2219	9	7
7J015	1054035	4735-01-492-2221	9	8
7J015	1054040	4710-01-492-2225	9	9
7J015	1054043	5340-01-492-0919	9	10
7J015	1054045	5340-01-492-0922	9	11
7J015	1054047	4730-01-492-2227	9	12
7J015	1054050	4710-01-492-2229	9	15
7J015	1054060	4710-01-492-2232	9	23
7J015	1054100	2350-01-492-2215	7	3
7J015	1054400		7	4
7J015	1054430-1		7	6
7J015	1054430-2		7	10
7J015	1054440		7	5
7J015	1054480		7	14
7J015	1054516		7	13
7J015	1054570	5340-01-492-0911	7	12
7J015	1054580		12	1
7J015	1054585	2540-01-492-2243	12	4
7J015	1054600	5306-01-492-0929	12	2
7J015	1054610-1	5306-01-492-0980	7	1
7J015	1054610-2	5306-01-492-0980	12	9
7J015	1054620		12	10
7J015	1055005	5340-01-487-5091	3	14

TM 9-2330-324-14&P

PART NUMBER INDEX

0085 00

CAGEC	PN	NSN	FIG	ITEM
7J015	1055020	5845-01-168-0148	3	1
7J015	1055030	6150-01-492-2003	3	15
7J015	1055040	6150-01-492-2004	3	18
7J015	1055050	6150-01-492-2005	3	25
7J015	1055060	6150-01-492-2006	3	26
7J015	1055070		1	11
7J015	1055090		3	13
7J015	1056100		4	1
7J015	1058000		17	5
7J015	1058037		17	14
7J015	1058038		17	13
7J015	1058230	2510-01-487-5442	18	12
7J015	1058235	2541-01-492-2255	18	17
7J015	1058282	4010-01-492-2165	18	2
7J015	1058287	5315-01-492-0969	18	1
7J015	1058290-1		18	15
7J015	1058290-2		18	15
7J015	1058295-1		18	8
7J015	1058395	3995-01-492-0957	17	7
7J015	1058460	3040-01-492-2258	19	2
7J015	1058470	5340-01-492-0973	19	3
7J015	1058480		17	6
7J015	1058480		19	1
7J015	1058500		17	11
7J015	1058510		17	12
7J015	1058520		17	17
19207	10910884	2530-01-492-9908	10	7
19207	10910885	5330-00-246-8223	10	8
19207	11639519-2	5331-00-462-0907	1	3
19207	11639520	6220-01-067-4717	1	4
19207	11639535	6220-00-179-4324	1	12
19207	12360850-1	6220-01-284-2709	1	6
19207	12360870-2	6220-01-297-3217	1	5
80204	1251	6240-00-019-0877	2	5
5B707	138-769-895		11	1
23705	296243	2510-00-752-1826	16	7
30076	339589	5342-00-991-4342	5	25
56442	348S3	2510-00-752-1841	16	8
19207	5298653	5365-00-274-4544	9	21
19207	5323088	5310-00-641-9939	6	18
19204	572929	5999-00-057-2929	3	8

TM 9-2330-324-14&P

PART NUMBER INDEX

0085 00

CAGEC	PN	NSN	FIG	ITEM
19204	572929	5999-00-057-2929	3	24
78500	5RE72E	2510-00-736-8628	16	12
19207	6161059A	9905-00-205-2795	20	1
19207	7373260	2530-00-737-3260	8	2
19207	7411042	2510-00-741-1042	16	14
19207	7411378	5310-00-741-1378	10	10
19207	7411379	5310-00-741-1379	10	9
19207	7411429	5330-00-741-1429	10	22
19207	7411433	5365-00-741-1433	10	19
19207	7411760	5306-00-741-1760	6	13
19207	7412068	2530-00-741-2068	6	12
82646	7412079	4730-00-729-6437	9	22
19207	7412088	5310-00-741-2088	9	20
19207	7412103	5365-00-741-2103	6	19
19207	7413231	2530-00-741-3231	10	21
19207	7745464	4730-00-419-9425	9	16
19207	7979519	2590-01-376-8844	16	6
19207	7979525	2510-01-194-9890	16	5
19207	7979573	5340-01-393-8017	16	15
19207	7979574	5340-01-392-8919	16	13
19207	8327047	5306-00-174-4311	16	11
19207	8336705	2530-00-770-9150	6	24
19207	8336789	2530-00-770-9151	6	24
19207	8338561	5935-00-833-8561	3	2
19207	8338561	5935-00-833-8561	3	19
19207	8338562	5970-00-833-8562	3	3
19207	8338562	5970-00-833-8562	3	20
19207	8338564	5940-00-399-6676	3	4
19207	8338564	5940-00-399-6676	3	21
19207	8338566	5835-00-572-9180	3	22
19207	8338566	5935-00-572-9180	3	6
19207	8338567	5310-00-833-8567	3	7
19207	8338567	5310-00-833-8567	3	23
19207	8719913	2530-00-741-1425	10	14
19207	8719915	2530-00-677-0202	10	12
19207	8720024	5310-00-655-9599	10	16
18876	8720025	5306-00-335-4768	10	20
19207	8720515	5360-00-699-9018	6	1
19207	8733892	2530-00-522-1157	6	21
21450	8733893	2530-00-794-9763	6	21
19207	8733908	2530-00-159-8755	6	20

TM 9-2330-324-14&P

PART NUMBER INDEX

0085 00

CAGEC	PN	NSN	FIG	ITEM
19207	8733909	2530-00-159-8756	6	20
19207	8733911	2530-00-973-2355	6	5
19207	8733912	2530-00-973-2356	6	5
19207	8733918	4710-00-630-9928	9	19
19207	8733920	4710-00-566-7133	9	17
19207	8733922	4710-00-566-7134	9	19
19207	8733926	3040-00-150-7127	6	7
19207	8733927	3040-00-074-2357	6	7
19207	8733933	2530-01-083-5641	6	11
19207	8733935	5310-00-314-0764	6	4
19207	8733936	5310-00-314-0765	6	3
19207	8733937	5310-00-322-7260	6	2
96906	99-51505-017	5310-00-619-4848	5	19
58536	A52463-1-09	6240-00-019-3093	1	8
78500	A8-3222W855	2530-00-693-1007	6	8
58536	A-A-52168-4	2530-00-441-0210	5	24
81348	A-A-52463-B10	6240-01-447-3779	1	7
81343	AS25036-154	5940-00-230-0515	3	17
80204	B1821BH025C063N	5305-00-068-7837	14	2
80204	B1821BH025C075N	5305-00-068-0508	14	5
80204	B1821BH025F100N	5305-00-068-0515	6	26
80204	B1821BH038C075D	5305-00-115-9526	1	10
			8	4
80204	B1821BH038C150N	5305-00-725-2317	16	3
80204	B1821BH038C175N	5305-00-821-3869	16	17
80204	B1821BH038C250N	5305-00-543-2866	5	17
80204	B1821BH038C300N	5305-00-846-5703	16	4
			16	10
80204	B1821BH050C350N	5305-00-071-2077	13	4
80204	B1821BH062C200N		17	4
63477	F14413	2530-00-741-2065	8	1
63477	F19636	5342-00-987-2565	5	25
63477	F9556	2530-00-741-2050	6	12
56190	FC13927	4730-00-741-1903	9	18
63477	FC-17758	5315-00-322-7261	6	6
63477	FC22219	5305-00-770-9149	6	23
63477	FD13351	4710-00-741-1907	9	17
81348	FFB187/01-490	3110-00-100-5951	10	11
81349	M45913/1-4CG5C	5310-00-088-1251	14	6
			14	11
			18	3

TM 9-2330-324-14&P

PART NUMBER INDEX

0085 00

CAGEC	PN	NSN	FIG	ITEM
81349	M45913/1-5CG5C	5310-00-984-3806	19	7
81349	M45913/1-8CBB	5310-00-008-7843	18	18
81349	M45913/1-8CG5C	5310-00-225-6993	13	1
96906	MS15001-1	4730-00-050-4203	16	9
96906	MS20392-4C39	5315-00-903-5943	5	4
96906	MS20392-5C29	5315-00-825-8353	5	13
96906	MS20392-7C105	5315-00-904-1636	18	6
96906	MS20604S4T5		21	2
96906	MS21333-71	5340-00-057-2904	3	10
			9	3
80205	MS24630-36	5305-00-052-9051	7	11
80205	MS24665-285	5315-01-359-1451	5	2
			5	14
80205	MS24665-423	5315-00-013-7228	7	17
			12	5
			19	5
80205	MS24665-436	5315-00-236-8368	18	7
96906	MS27183-10	5310-00-809-4058	14	20
			18	14
96906	MS27183-11	5310-00-809-3078	5	6
			17	8
96906	MS27183-12	5310-00-081-4219	5	3
			7	7
			18	9
96906	MS27183-14	5310-00-080-6004	5	18
			10	15
			16	2
			17	15
96906	MS27183-17	5310-00-809-5997	13	2
96906	MS27183-18	5310-00-809-5998	18	19
96906	MS27183-21	5310-00-823-8803	12	3
			17	3
96906	MS27183-23	5310-00-809-8533	7	2
			12	7
			19	4
96906	MS27183-52	5310-01-274-3255	18	4
			20	3
96906	MS27183-57	5310-01-280-5796	14	14
96906	MS27183-9	5310-00-823-8804	14	9
96906	MS35206-267	5305-00-984-6214	2	4
96906	MS35206-279	5305-00-988-1723	10	5

TM 9-2330-324-14&P

PART NUMBER INDEX

0085 00

CAGEC	PN	NSN	FIG	ITEM
96906	MS35206-279	5305-00-988-1723	20	2
96906	MS35335-32	5310-00-596-7691	2	9
96906	MS35335-35	5310-00-627-6128	6	15
96906	MS35335-37	5310-00-209-5116	6	9
96906	MS35338-24	5310-00-043-2226	2	7
96906	MS35338-25	5310-00-012-1637	14	3
96906	MS35338-26	5310-00-012-0214	18	10
96906	MS35338-27	5310-00-543-2705	5	22
96906	MS35338-30	5310-00-012-0898	17	2
96906	MS35338-43	5310-00-045-3296	3	11
			9	4
96906	MS35338-44	5310-00-582-5965	5	21
			6	16
			9	13
			10	6
			20	4
96906	MS35338-45	5310-00-407-9566	5	7
			7	8
			7	16
			17	9
			19	8
96906	MS35338-46	5310-00-637-9541	1	9
			14	15
96906	MS35338-63	5310-00-274-8715	5	26
96906	MS35338-8	5310-00-261-7340	8	3
96906	MS35387-2	9905-00-202-3639	20	1
96906	MS35421-2	6220-00-299-7426	2	3
96906	MS35422-1	6220-00-729-9295	2	2
96906	MS35423-2	6220-00-726-1916	2	1
96906	MS35649-202	5310-00-934-9758	2	8
			3	12
			9	5
96906	MS35692-49	5310-00-850-6876	12	6
96906	MS35692-57	5310-00-850-6881	7	18
			12	8
			19	6
96906	MS39020-1		3	5
			3	16
96906	MS51849-76	5305-00-240-0194	2	6
			3	9
			9	2

TM 9-2330-324-14&P

PART NUMBER INDEX

0085 00

CAGEC	PN	NSN	FIG	ITEM
96906	MS51922-17	5310-00-087-4652	16	1
96906	MS51922-61	5310-00-832-9719	16	16
96906	MS51943-31	5310-00-061-4650	14	21
			18	16
96906	MS51943-46	5310-00-935-3569	10	13
96906	MS51946-11	5306-00-206-1560	10	18
96906	MS51946-2	5306-00-383-4957	10	17
96906	MS51967-2	5310-00-761-6882	5	20
			5	27
			9	14
			20	5
96906	MS51967-20	5310-00-763-8920	17	1
96906	MS51967-5	5310-00-880-7744	5	8
			17	10
96906	MS51967-8	5310-00-732-0558	5	23
			14	16
			17	16
96906	MS51968-8	5310-00-732-0559	5	11
			6	14
96906	MS51970-1	5310-00-924-4218	6	17
96906	MS51970-4	5310-00-903-3993	6	10
96906	MS52125-2	6220-01-093-4439	1	1
96906	MS90725-10	5305-00-068-0509	18	13
80205	MS90725-119	5305-00-071-1772	18	20
96906	MS90725-13	5306-01-303-2815	5	15
80205	MS90725-15	5305-00-071-2236	14	8
			14	19
96906	MS90725-31	5306-00-225-8496	7	15
			18	11
96906	MS90725-32	5306-01-362-2851	7	9
96906	MS90725-34	5306-00-225-8499	5	5
96906	MS90725-6	5305-00-068-0502	18	5
80205	MS90725-62	5305-00-269-3213	14	13
96906	MS90726-61	5305-00-269-2804	6	22
96906	MS90726-65	5305-00-269-3241	6	25

TORQUE LIMITS

0086 00

SCOPE

This WP lists standard torque values (Table 1) and provides general information for applying torque. Special torque values and tightening sequences are included in the maintenance procedures for applicable components.

GENERAL

Always use the torque values listed in Table 1 when the maintenance procedure does not give a specific torque value.

Unless otherwise specified, standard torque tolerance shall be $\pm 10\%$.



Torque values are based on clean, dry threads. Reduce torque by 10% when engine oil is used as a lubricant. Reduce torque by 20% if new plated capscrews are used.

Capscrews threaded into aluminum may require reductions in torque of 30% or more of Grade 5 capscrew torque. Capscrews threaded into aluminum must also attain two capscrew diameters of thread engagement.

CAUTION

If replacement capscrews are of a higher grade than originally supplied, use torque specifications for the original. This will prevent equipment damage due to overtorquing.

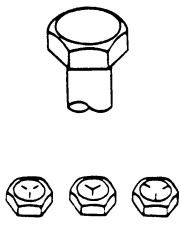
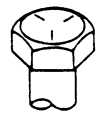
Table 1. Torque Limits.

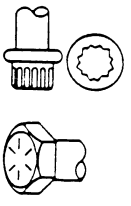
CURRENT USAGE	MUCH USED	MUCH USED	USED AT TIMES	USED AT TIMES
QUALITY OF MATERIAL	INDETERMINATE	MINIMUM COMMERCIAL	MEDIUM COMMERCIAL	BEST COMMERCIAL
SAE GRADE NUMBER CAPSCREW HEAD MARKINGS MANUFACTURER'S MARKS MAY VARY THESE ARE ALL SAE GRADE 5 (3 LINE)	<p>1 OR 2</p> 	<p>5</p> 	<p>6 OR 7</p> 	<p>8</p> 
CAPSCREW BODY SIZE inches – thread	TORQUE lb-ft (N•m)	TORQUE lb-ft (N•m)	TORQUE lb-ft (N•m)	TORQUE lb-ft (N•m)
1/4 20 28	5 (7) 6 (8)	8 (11) 10 (14)	10 (14)	12 (16) 14 (19)
5/16 18 24	11 (15) 13 (18)	17 (23) 19 (26)	19 (26)	24 (33) 27 (37)
3/8 16 24	18 (24) 20 (27)	31 (42) 35 (47)	34 (46)	44 (60) 49 (66)
7/16 14 20	28 (38) 30 (41)	49 (66) 55 (75)	55 (75)	70 (95) 78 (106)
1/2 13 20	39 (53) 41 (56)	75 (102) 85 (115)	85 (115)	105 (142) 120 (163)
9/16 12 18	51 (69) 55 (75)	110 (149) 120 (163)	120 (163)	155 (210) 170 (231)
5/8 11 18	83 (113) 95 (129)	150 (203) 170 (231)	167 (226)	210 (285) 240 (325)
3/4 10 16	105 (142) 115 (156)	270 (366) 295 (400)	280 (380)	375 (508) 420 (569)
7/8 9 14	160 (217) 175 (237)	395 (536) 435 (590)	440 (597)	605 (820) 675 (915)
1 8 14	235 (319) 250 (339)	590 (800) 660 (895)	660 (895)	910 (1234) 990 (1342)

INDEX

Subject	Page No.
A	
AAL.....	0059 00-1
Abbreviations/Acronyms.....	0001 00-2
Axle:	
Repair Parts.....	0066 00-1
Replacement.....	0052 00-1
B	
Brake Shaft Assembly:	
Location and Description.....	0002 00-6
Repair Parts.....	0067 00-1
Brake System:	
Adjustment.....	0033 00-5
Bleeding.....	0038 00-1
Hydraulic Brake Lines and Fittings Repair Parts.....	0071 00-1
Hydraulic Brake Lines and Fittings Replacement.....	0037 00-1
Location and Description.....	0002 00-3, 0002 00-7
Operator/Crew Troubleshooting.....	0012 00-1
Organizational Troubleshooting.....	0016 00-1
Repair Parts.....	0068 00-1
Service Brake Assembly Maintenance.....	0033 00-1
Theory of Operation.....	0004 00-1
Brakedrum:	
Inspection.....	0053 00-1
Location and Description.....	0002 00-7
Maintenance.....	0039 00-1
Repair.....	0053 00-1
Brake Actuator:	
Location and Description.....	0002 00-3, 0002 00-7
Master Cylinder Description and Use.....	0006 00-4
Master Cylinder Fluid Level.....	0023 00-4
Repair Parts.....	0069 00-1
Replacement.....	0034 00-1
C	
Cable Assembly Repair.....	0030 00-1
Cargo Body:	
Location and Description.....	0002 00-4
Maintenance.....	0056 00-1
Repair.....	0056 00-2
Repair Parts.....	0079 00-1
Cargo Tiedown:	
Description and Use.....	0006 00-7
Location and Description.....	0002 00-4
Repair Parts.....	0077 00-1
Replacement.....	0045 00-1
Chassis Wiring Harness:	
Location and Description.....	0002 00-5
Repair Parts.....	0065 00-1

INDEX—Continued

Subject	Page No.
C—Continued	
Chassis Wiring Harness—Continued:	
Replacement.....	0028 00-1
Schematic.....	0025 00-1
Composite Light:	
Location and Description.....	0002 00-4, 0002 00-5
Maintenance.....	0026 00-1
Repair Parts.....	0063 00-1
Connector Repair.....	0030 00-2
Coupling Trailer to Towing Vehicle.....	0007 00-1
CPC.....	0001 00-2
D	
D-Ring:	
Description and Use.....	0006 00-7
Location and Description.....	0002 00-3
Repair Parts.....	0075 00-1
Replacement.....	0048 00-1
Data Plate:	
Location and Content.....	0002 00-8
Repair Parts.....	0083 00-1
Replacement.....	0050 00-1
Description and Use of Controls and Indicators.....	0006 00-1
Destruction of Army Materiel to Prevent Enemy Use.....	0001 00-2
Drawbar Coupler:	
Description and Use.....	0006 00-3
Location and Description.....	0002 00-3
Repair Parts.....	0074 00-1
Replacement.....	0041 00-1
E	
Electrical System:	
Location and Description.....	0002 00-5
Operator/Crew Troubleshooting.....	0011 00-1
Organizational Troubleshooting.....	0015 00-1
Schematic.....	0025 00-1
Theory of Operation.....	0003 00-1
Emergency Braking Breakaway Cable:	
Description and Use.....	0006 00-5
Location and Description.....	0002 00-3
Emergency Braking Breakaway Lever:	
Description and Use.....	0006 00-5
Location and Description.....	0002 00-3
Reset.....	0035 00-1
Equipment Characteristics, Capabilities, and Features.....	0002 00-1
Equipment Data.....	0002 00-9
Expendable and Durable Items List.....	0060 00-1

INDEX—Continued

Subject	Page No.
F	
Female Connector Repair.....	0030 00-2
Fluid Level of Brake Actuator Master Cylinder	0023 00-4
Fording.....	0008 00-1
Frame Assembly:	
Location and Description.....	0002 00-3
Repair.....	0055 00-1
G	
General:	
Cleaning Instructions	0024 00-2
Inspection Instructions.....	0024 00-3
Maintenance Instructions	0024 00-1
Repair Instructions.....	0024 00-4
Work Safety.....	0024 00-1
H	
Handbrake Lever:	
Adjustment	0019 00-1
Adjustment Knob Description and Use.....	0006 00-6
Description and Use.....	0006 00-6
Location and Description.....	0002 00-3, 0002 00-6
Replacement.....	0031 00-1
Handbrake Linkage and Cables:	
Adjustment	0032 00-7
Repair Parts.....	0067 00-1
Maintenance	0032 00-1
Handles:	
Description and Use.....	0006 00-3
Location and Description.....	0002 00-3
Hoses, Tagging.....	0024 00-4
I	
Identification Band Replacement	0030 00-1
Intervehicular Cable Assembly:	
Description and Use.....	0006 00-3
Location and Description.....	0002 00-3, 0002 00-5
Repair Parts.....	0065 00-1
Replacement.....	0029 00-1
Schematic.....	0025 00-1
L	
Ladder:	
Description and Use.....	0006 00-8
Location and Description.....	0002 00-4
Replacement.....	0046 00-1
Lamp Replacement.....	0026 00-1, 0027 00-1
Landing Gear:	
Description and Use.....	0006 00-2

INDEX—Continued

Subject	Page No.
L—Continued	
Landing Gear—Continued:	
Location and Description.....	0002 00-3
Repair Parts.....	0076 00-1
Replacement.....	0043 00-1
Lashing Hooks Location and Description.....	0002 00-4
Leakage Definitions.....	0017 00-3
LED Replacement.....	0026 00-1
Loading Trailer.....	0007 00-6
Location and Description of Major Components.....	0002 00-2
Lubrication Instructions.....	0018 00-1, 0023 00-1
M	
MAC.....	0058 00-1
Male Connector Repair.....	0026 00-2
Major Components Location and Description.....	0002 00-2
Master Cylinder Description and Use.....	0006 00-4
MRP List.....	0061-00-1
N	
NSN Index.....	0084 00-1
O	
Operation:	
In Dusty Areas.....	0008 00-1
In Extreme Cold.....	0008 00-1
In Extreme Heat.....	0008 00-1
In Mud.....	0008 00-1
In Saltwater Areas.....	0008 00-1
In Sandy Areas.....	0008 00-1
In Snow.....	0008 00-1
Under Unusual Conditions.....	0008 00-1
Under Usual Conditions.....	0007 00-1
Operator/Crew:	
Lubrication Instructions.....	0018 00-1
PMCS.....	0017 00-1
Troubleshooting.....	0011 00-1, 0012 00-1
Troubleshooting Introduction.....	0009 00-1
Troubleshooting Malfunction/Symptom Index.....	0010 00-1
Organizational:	
Lubrication Instructions.....	0023 00-1
PMCS.....	0022 00-1
Troubleshooting.....	0015 00-1, 0016 00-1
Troubleshooting Malfunction/Symptom Index.....	0014 00-1
Troubleshooting Introduction.....	0013 00-1
P	
Part Number Index.....	0085 00-1
PMCS.....	0017 00-1, 0022 00-1

INDEX—Continued

Subject	Page No.
P—Continued	
Preparation for Storage or Shipment.....	0051 00-1
R	
References.....	0057 00-1
Reflector:	
Location and Description.....	0002 00-4
Repair Parts.....	0082 00-1
Replacement.....	0049 00-1
Roof Bows Location and Description.....	0002 00-4
RPSTL.....	0062 00-1 through 0085 00-3
Running Light:	
Location and Description.....	0002 00-4, 0002 00-5
Replacement.....	0027 00-1
Repair Parts.....	0064 00-1
S	
Safety Chain:	
Description and Use.....	0006 00-3
Location and Description.....	0002 00-3
Maintenance.....	0042 00-1
Repair Parts.....	0074 00-1
Schematic, Electrical.....	0025 00-1
Service Brake Assembly:	
Maintenance.....	0033 00-1
Repair Parts.....	0068 00-1
Service Upon Receipt.....	0021 00-1
Shipment or Storage, Preparation for.....	0051 00-1
Sling Loading Trailer.....	0007 00-6
Spare Wheel Location and Description.....	0002 00-3
Spare Wheel Rack:	
Adjustment.....	0047 00-2
Description and Use.....	0006 00-10
Repair Parts.....	0081 00-1
Maintenance.....	0047 00-1
Special Tools.....	0005 00-1
Spring:	
Location and Description.....	0002 00-3
Maintenance.....	0044 00-1
Repair Parts.....	0078 00-1
Stabilizer:	
Location and Description.....	0002 00-4
Repair Parts.....	0077 00-1
Stabilizer Mount:	
Description and Use.....	0006 00-9
Location and Description.....	0002 00-4
Stake Racks Location and Description.....	0002 00-4
Storage or Shipment, Preparation for.....	0051 00-1
Support Equipment.....	0005 00-1

INDEX—Continued

Subject	Page No.
T	
Tagging Wires and Hoses.....	0024 00-4
Tailgate:	
Description and Use.....	0006 00-8
Location and Description.....	0002 00-4
Repair Parts.....	0080 00-1
Replacement.....	0046 00-1
Tarpaulin Location and Description	0002 00-4
Terminal Replacement	0030 00-1
Tire:	
Maintenance	0040 00-1
Repair.....	0054 00-1
Repair Parts.....	0073 00-1
TMDE	0005 00-1
Torque Limits	0086 00-1
Towing Trailer.....	0007 00-3
Troubleshooting:	
Brake System Operator/Crew	0012 00-1
Brake System Organizational.....	0016 00-1
Electrical System Operator/Crew.....	0011 00-1
Electrical System Organizational	0015 00-1
U	
Uncoupling Trailer from Towing Vehicle.....	0007 00-4
W	
Wheel Bearing Maintenance.....	0039 00-1
Wheel Cylinder:	
Repair Parts.....	0070 00-1
Replacement.....	0036 00-1
Wheel Hub:	
Maintenance	0039 00-1
Repair Parts.....	0072 00-1
Wheel:	
Repair Parts.....	0071200-1
Replacement.....	0020 00-1
Wires, Tagging	0024 00-4
Wiring Harness Repair	0030 00-1

TO: <i>(Forward direct to addressee listed in publication)</i>	FROM: <i>(Activity and location) (Include ZIP Code)</i>	DATE
---	--	-------------

PART II - REPAIR PARTS AND SPECIAL TOOL LISTS AND SUPPLY CATALOGS/SUPPLY MANUALS

PUBLICATION NUMBER			DATE		TITLE			
PAGE NO.	COLM NO.	LINE NO.	NATIONAL STOCK NUMBER	REFERENCE NO.	FIGURE NO.	ITEM NO.	TOTAL NO. OF MAJOR ITEMS SUPPORTED	RECOMMENDED ACTION

PART III - REMARKS *(Any general remarks or recommendations, or suggestions for improvement of publications and blank forms. Additional blank sheets may be used if more space is needed.)*

TYPED NAME, GRADE OR TITLE	TELEPHONE EXCHANGE/AUTOVON, PLUS EXTENSION	SIGNATURE
----------------------------	--	-----------

TO: <i>(Forward direct to addressee listed in publication)</i>	FROM: <i>(Activity and location) (Include ZIP Code)</i>	DATE
---	--	-------------

PART II - REPAIR PARTS AND SPECIAL TOOL LISTS AND SUPPLY CATALOGS/SUPPLY MANUALS

PUBLICATION NUMBER			DATE	TITLE				
PAGE NO.	COLM NO.	LINE NO.	NATIONAL STOCK NUMBER	REFERENCE NO.	FIGURE NO.	ITEM NO.	TOTAL NO. OF MAJOR ITEMS SUPPORTED	RECOMMENDED ACTION

PART III - REMARKS *(Any general remarks or recommendations, or suggestions for improvement of publications and blank forms. Additional blank sheets may be used if more space is needed.)*

TYPED NAME, GRADE OR TITLE	TELEPHONE EXCHANGE/AUTOVON, PLUS EXTENSION	SIGNATURE
----------------------------	--	-----------

THE METRIC SYSTEM AND EQUIVALENTS

LINEAR MEASURE

1 Centimeter = 10 Millimeters = 0.01 Meters = 0.3937 Inches
 1 Meter = 100 Centimeters = 1000 Millimeters = 39.37 Inches
 1 Kilometer = 1000 Meters = 0.621 Miles

SQUARE MEASURE

1 Sq Centimeter = 100 Sq Millimeters = 0.155 Sq Inches
 1 Sq Meter = 10,000 Sq Centimeters = 10.76 Sq Feet
 1 Sq Kilometer = 1,000,000 Sq Meters = 0.386 Sq Miles

WEIGHTS

1 Gram = 0.001 Kilograms = 1000 Milligrams = 0.035 Ounces
 1 Kilogram = 1000 Grams = 2.2 Lb
 1 Metric Ton = 1000 Kilograms = 1 Megagram = 1.1 Short Tons

CUBIC MEASURE

1 Cu Centimeter = 1000 Cu Millimeters = 0.06 Cu Inches
 1 Cu Meter = 1,000,000 Cu Centimeters = 35.31 Cu Feet

LIQUID MEASURE

1 Milliliter = 0.001 Liters = 0.0338 Fluid Ounces
 1 Liter = 1000 Milliliters = 33.82 Fluid Ounces

TEMPERATURE

$5/9 (°F - 32) = °C$
 212° Fahrenheit is equivalent to 100° Celsius
 90° Fahrenheit is equivalent to 32.2° Celsius
 32° Fahrenheit is equivalent to 0° Celsius
 $9/5 C° + 32 = F°$

APPROXIMATE CONVERSION FACTORS

TO CHANGE	TO	MULTIPLY BY
Inches	Centimeters	2.540
Feet	Meters	0.305
Yards	Meters	0.914
Miles	Kilometers	1.609
Square Inches	Square Centimeters	6.451
Square Feet	Square Meters	0.093
Square Yards	Square Meters	0.836
Square Miles	Square Kilometers	2.590
Acres	Square Hectometers	0.405
Cubic Feet	Cubic Meters	0.028
Cubic Yards	Cubic Meters	0.765
Fluid Ounces	Milliliters	29.573
Pints	Liters	0.473
Quarts	Liters	0.946
Gallons	Liters	3.785
Ounces	Grams	28.349
Pounds	Kilograms	0.454
Short Tons	Metric Tons	0.907
Pound-Feet	Newton-Meters	1.356
Pounds per Square Inch	Kilopascals	6.895
Miles per Gallon	Kilometers per Liter	0.425
Miles per Hour	Kilometers per Hour	1.609

TO CHANGE	TO	MULTIPLY BY
Centimeters	Inches	0.394
Meters	Feet	3.280
Meters	Yards	1.094
Kilometers	Miles	0.621
Square Centimeters	Square Inches	0.155
Square Meters	Square Feet	10.764
Square Meters	Square Yards	1.196
Square Kilometers	Square Miles	0.386
Square Hectometers	Acres	2.471
Cubic Meters	Cubic Feet	35.315
Cubic Meters	Cubic Yards	1.308
Milliliters	Fluid Ounces	0.034
Liters	Pints	2.113
Liters	Quarts	1.057
Liters	Gallons	0.264
Grams	Ounces	0.035
Kilograms	Pounds	2.205
Metric Tons	Short Tons	1.102
Newton-Meters	Pound-Feet	0.738
Kilopascals	Pounds per Square Inch	0.145
Kilometers per Liter	Miles per Gallon	2.354
Kilometers per Hour	Miles per Hour	0.621

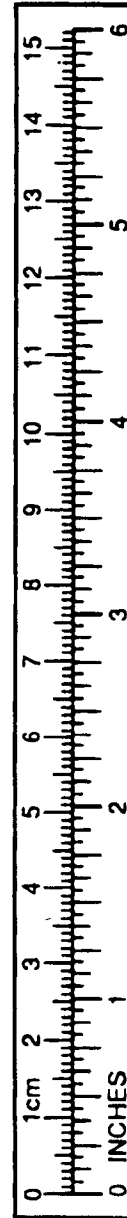

299

PIN: 080220-000