

**LUBRICATION ORDER
JUNE 1990**

**ARMY LO 9-2320-272-12
AIR FORCE TO 36A12-1C-441LC-1**

(Supersedes LO 9-2320-272-12, 11 April 1986)

TRUCK, 5-TON, 6X6, M939, M939A1 AND M939A2 SERIES (DIESEL)

TRUCK, CARGO: 5-TON, 6X6, DROPSIDE,

M923 (2320-01-050-2084), M923A1 (2320-01-206-4087), M923A2 (2320-01-230-0307)
M925 (2320-01-047-8769), M925A1 (2320-01-206-4088), M925A2 (2320-01-230-0308);

TRUCK, CARGO: 5-TON, 6X6

M924 (2320-01-047-8773), M924A1 (2320-01-205-2692),
M926 (2320-01-047-8772), M926A1 (2320-01-205-2693):

TRUCK, CARGO: 5-TON, 6X6, XLWB,

M927 (2320-01-047-8771), M927A1 (2320-01-206-4089), M927A2 (2320-01-230-0309),
M926 (2320-01-047-8770), M928A1 (2320-01-206-4090), M928A2 (2320-01-230-0310);

TRUCK, DUMP: 5-TON, 6X6,

M929 (2320-01-047-8756), M929A1 (2320-01-206-4079), M929A2 (2320-01-230-0305),
M930 (2320-01-047-8755), M930A1 (2320-01-206-4080), M930A2 (2320-01-230-0306);

TRUCK, TRACTOR: 5-TON, 6X6,

M931 (2320-01-04-8753), M931A1 (2320-01-206-4077), M931A2 (2320-01-230-0302),
M932 (2320-01-047-8752), M932A1 (2320-01-205-2684), M932A2 (2320-01-230-0303);

TRUCK, VAN, EXPANSIBLE: 5-TON 6X6,

M934 (2320-01-047-8750), M934A1 (2320-01-205-2662), M934A2 (2320-01-230-0300),
M935 (2320-01-047-8751), M935A1, (2320-01-205-2683), M935A2 (2320-01-230-0301);

TRUCK, MEDIUM WRECKER: 5-TON, 6X6,

M936 (2320-01-047-854), M936A1 (2320-01-206-4078), M936A2 (2320-01-230-0304)

REFERENCE: TM 9-2320-272-10, TM 9-2320-272-20-1, TM 9-2320-272-20-2 and TM 9-2320-356-24&P

Intervals (on-condition or hard time) and the related mm-hour times are based on normal operation. The man-hour time specified is the time you need to do all the services prescribed for a particular interval. On-condition (OC) oil sample intervals shall be applied unless changed by the army Oil Analysis Program (AOAP) laboratory. Change the hard time interval if your lubricants are contaminated or if you are operating the equipment under adverse operating conditions, including longer-than-usual operating hours. The hard time interval may be extended during periods of low level activity. If extended, adequate preservation precautions must be taken. Hard time intervals will be applied in the event AOAP laboratory support is not available.

Clean fittings before lubricating. Clean parts with drycleaning solvent, (SD) type II or equivalent. Dry before lubricating. Dotted arrows indicate required lubrication on both sides of the equipment.

Level of maintenance. The lowest level of maintenance authorized to lubricate a point is indicated by one of the following symbols: Operator/Crew (C); and Organizational Maintenance (O).

Relubricate after fording.

REPORTING ERRORS AND RECOMMENDING IMPROVEMENTS

You can help improve this lubrication order. If you find any mistakes or if you know of a way to improve the procedures, please let us know. Mail your letter or DA Form 2028 (Recommended Changes to Publications and Blank Forms) direct to; Commander, US Army Tank-Automotive Command, ATTN: AMSTA-MB, Warren, Michigan 48397-5000. A reply will be furnished to you-

Approved for public release: distribution is unlimited.

TA 350335

LUBRICANTS	CAPACITIES	EXPECTED TEMPERATURES			INTERVALS
		Above +15°F (Above -9°C)	+40° to -15°F (+4° to -26°C)	+40° to -65°F (+4° to -54°C)	
OE/HDO-LUBRICATING OIL INTERNAL COM- BUSTION ENGINE (MIL-L-2104)					<p>OC-On condition (AOAP)</p> <p>C/ME-Change gear lubricant only when required by maintenance repair action, or if contaminated by water or other foreign materials.</p> <p>D-Daily</p> <p>W-Weekly, as required, depending upon use; otherwise, during INTERVAL M</p> <p>M-1,000 miles* (1,600 km) or monthly, whichever occurs first</p> <p>Q-3,000 miles* (4,800 km) or 3 months, whichever occurs first</p> <p>S/S-2,000 miles* (4,800 km) or 6 months, whichever occurs first</p> <p>S-6,000 miles* (9,600 km) or 6 months, whichever occurs first</p> <p>A-12,000 miles* (19,000 km) or 12 months, whichever occurs first</p> <p>B-24,000 miles* (38,000 km) or 24 months, whichever occurs first</p>
OEA-LUBRICATING OIL INTERNAL COM- BUSTION ENGINE (ARCTIC) (MIL-L-46167)					
OIL CAN POINTS		OE/HDO 90	OE/HDO 10	OEA	
CRANKCASE:		OE/HDO 90	OE/HDO 10	OEA	
M939 & M939A1 SERIES VEHICLES W/FILTER	27 qt (25.5 l)				
M939A2 SERIES VEHICLES W/FILTER	20 qt (18.9 l)				
M939 AND M939A1 SERIES VEHICLES WO FILTER	23 qt (21.8 l)				
M939A2 SERIES VEHICLES W/O FILTER	18 qt (17.0 l)				
TRANSMISSION:		OE/HDO 10	OE/HDO 10	OEA	
DRY	23 qt (21.8 l)				
W/PTO	25 qt (23.7 l)				
DRAIN & REFILL W/PTO	17 qt (16.1 l)				
STEERING AND HYDRAULIC SYSTEMS (INCLUDING STEER- ING GEARBOX):					
STEERING SYSTEM RESERVOIR					
M939A AND M939A1	5 qt (4.7 l)	OE/HDO 10	OE/HDO 10	OEA	
M939A2	3 qt (2.8 l)	OE/HDO 10	OE/HDO 10	OEA	
HYDRAULIC SYSTEMS:		OE/HDO 10	OE/HDO 10	OEA	
M925, M925A1, M925A2 CARGO W/W	32 qt (30.3 l)				
M926, M926A1 CARGO W/W	32 qt (30.3 l)				
M928, M928A1, M928A2 XLWB CARGO W/W	32 qt (30.3 l)				
M929, M929A1, M929A2 DUMP WO/W	20 qt (18.9 l)				
M930, M930A1, M930A2 DUMP W/W	25 qt (23.7 l)				
M932, M932A1, M932A2 TRACTOR W/W	32 qt (30.3 l)				
M935, M935A1, M935A2 EXPANSIBLE VAN	12 qt (11.4 l)				
M936, M936A1, M936A2 MEDIUM WRECKER	100 gal. (378.5 l)				
GO-LUBRICATING OIL GEAR MULTIPURPOSE (MIL-L-2105)					
TRANSFER CASE	6.5 qt (6.1 l)	GO 80/90	GO 80/90	GO 75	
FRONT DIFFERENTIAL	12 qt (11.4 l)	GO 80/90	GO 80/90	GO 75	
REAR DIFFERENTIAL	12 qt (11.4 l)	GO 80/90	GO 80/90	GO 75	
FRONT WINCH GEARCASE	2.6 pt (1.2 l)	GO 80/90	GO 80/90	GO 75	
REAR WINCH GEARCASE	3 pt (1.4 l)	GO 80/90	GO 80/90	GO 75	

FOR ARCTIC OPERATION, REFER TO FM 8-207

* See note 1.

-KEY- (Cont'd)

LUBRICANTS	CAPACITIES	EXPECTED TEMPERATURES			INTERVALS
		Above +15°F (Above -9°C)	+40° to -15°F (+4° to -26°C)	+40° to -65°F (+4° to -54°C)	
GAA-GREASE, AUTOMOTIVE AND ARTILLERY (MIL-G-10924)	X	ALL TEMPERATURES			X
CW-LUBRICATING OIL, CHAIN, WIRE-ROPE, AND EXPOSED-GEAR (VV-L-751) WINCH WIRE ROPE	X	Above +80°F(+27°C)	+80° to +30°F (+27° to -1°C)	+30° to -30°F (-1° to -34°C)	-30° to -65°F (-34° to -54°C)
	X	CW-IIC	CW-IIB	CW-IIA	GO 75
GW-GREASE, WIRE-ROPE AND EXPOSED GEAR (MIL-G-18458)	X	ALL TEMPERATURES			

FOR ARCTIC OPERATION, REFER TO FM 9-207

TOTAL MAN-HOURS

	D	W	M	Q	S	3/S	A	B	C/MR	OC
TRUCK, CHASSIS: 5-TON, 6X6, M939, M939A1, M940, M940A1, M941, M941A1, M942, M942A1, M943, M942A2, M943, M944, M944A1, M944A2, M945, M945A1	.3		.7	5.4	2.0	.5	2.1	.5	3.9	1.5
TRUCK, CARGO, DROPSIDE: 5-TON, 6X6, M923, M923A1, M923A2, M925, M925A1, M925A2	.3		.7	5.4	2.0	.5	2.1	.5	3.9	1.5
TRUCK, CARGO: 5-TON, 6X6, M924, M924A1, M926, M926A1	.3		.7	5.4	2.0	.5	2.1	.5	3.9	1.5
TRUCK, CARGO: 5-TON, 6X6, M927, M927A1, M927A2, M928, M928A1, M928A2	.3		.7	5.4	2.0	.6	2.1	.5	3.9	1.5
TRUCK, DUMP: 5-TON, 6X6, M929, M929A1, M929A2, M930, M930A1, M930A2	.3	.1	.7	5.4	2.3	.7	2.5	.5	3.9	1.5
TRUCK, TRACTOR: 5-TON, 6X6, M931, M931A1, M931A2, M932, M932A1, M932A2	.3		.7	5.7	2.0	.5	2.1	.5	3.9	1.5
TRUCK, VAN, EXPANSIBLE: 5-TON, 6X6, M934, M934A2, M935	.3		.7	5.4	2.7	.7	2.7	.5	4.9	1.5
TRUCK, VAN, EXPANSIBLE: 5-TON, 6X6, M934A1, M935A1, M935A2	.3		.7	5.4	2.7	.7	3.0	.5	4.9	1.5
TRUCK, WRECKER: 5-TON, 6X6, M936, M936A1, M936A2	.5	.2	1.0	5.4	9.8	.9	3.1	.5	4.9	1.5

NOTE

The man-hours shown above have been established on an individual vehicle basis and therefore are not applicable at maintenance facilities where production line methods are used.

TA 350537

NOTE

Lubrication entries followed by (LV) have localized views showing the appropriate lubrication points. Localized views begin on card 17.

INTERVAL • LUBRICANT

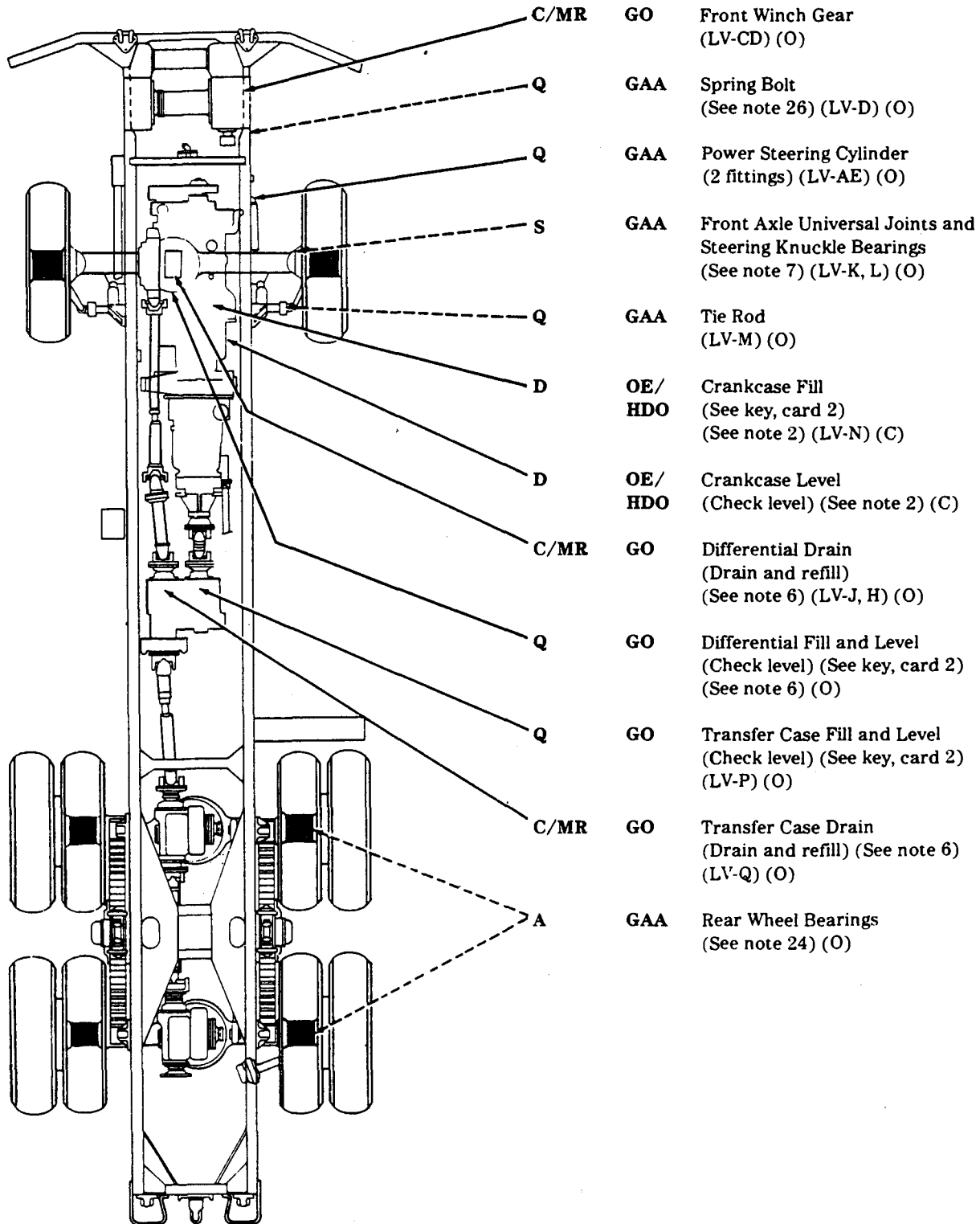

TA 350538

INTERVAL • LUBRICANT

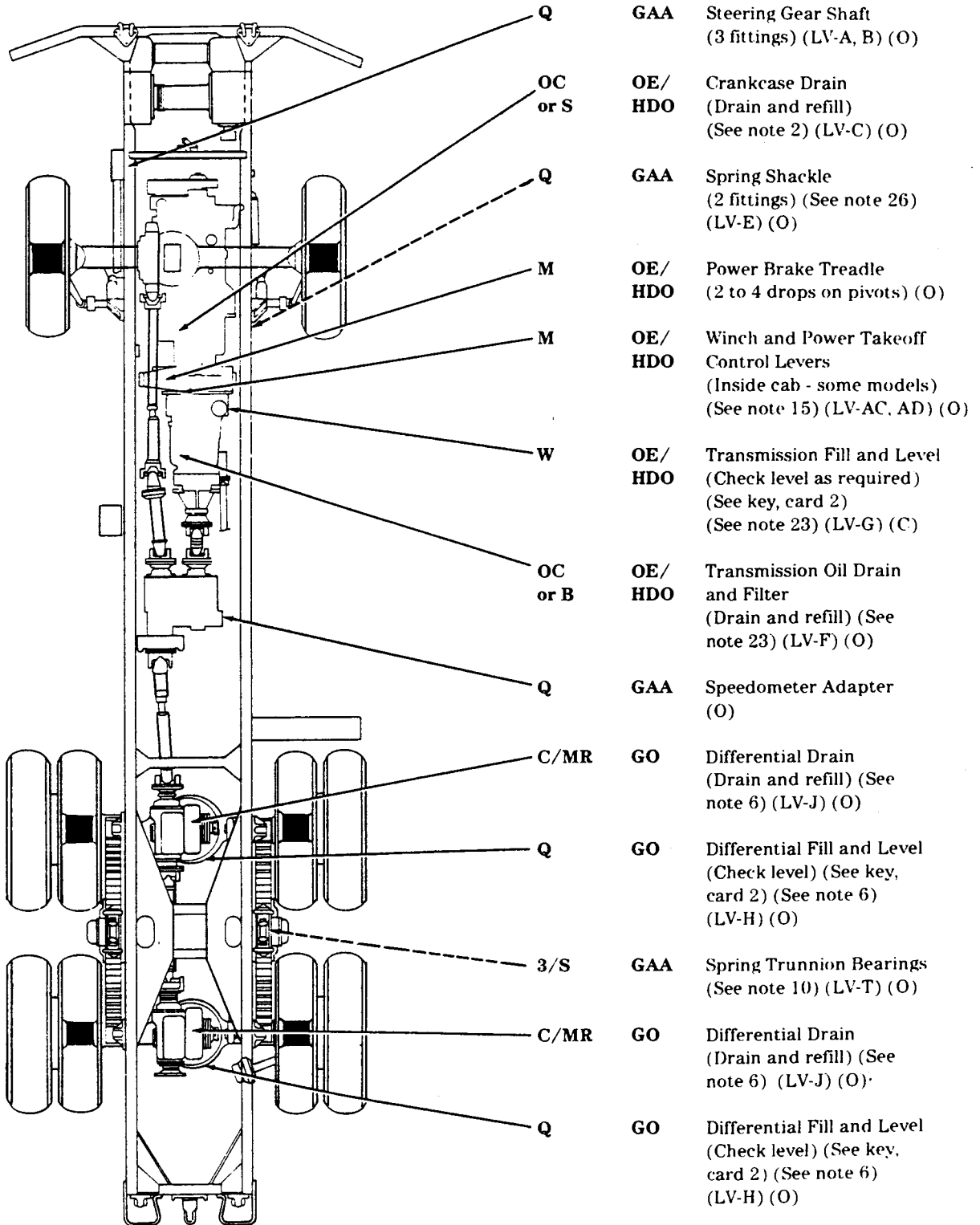

TA 350539

INTERVAL • LUBRICANT

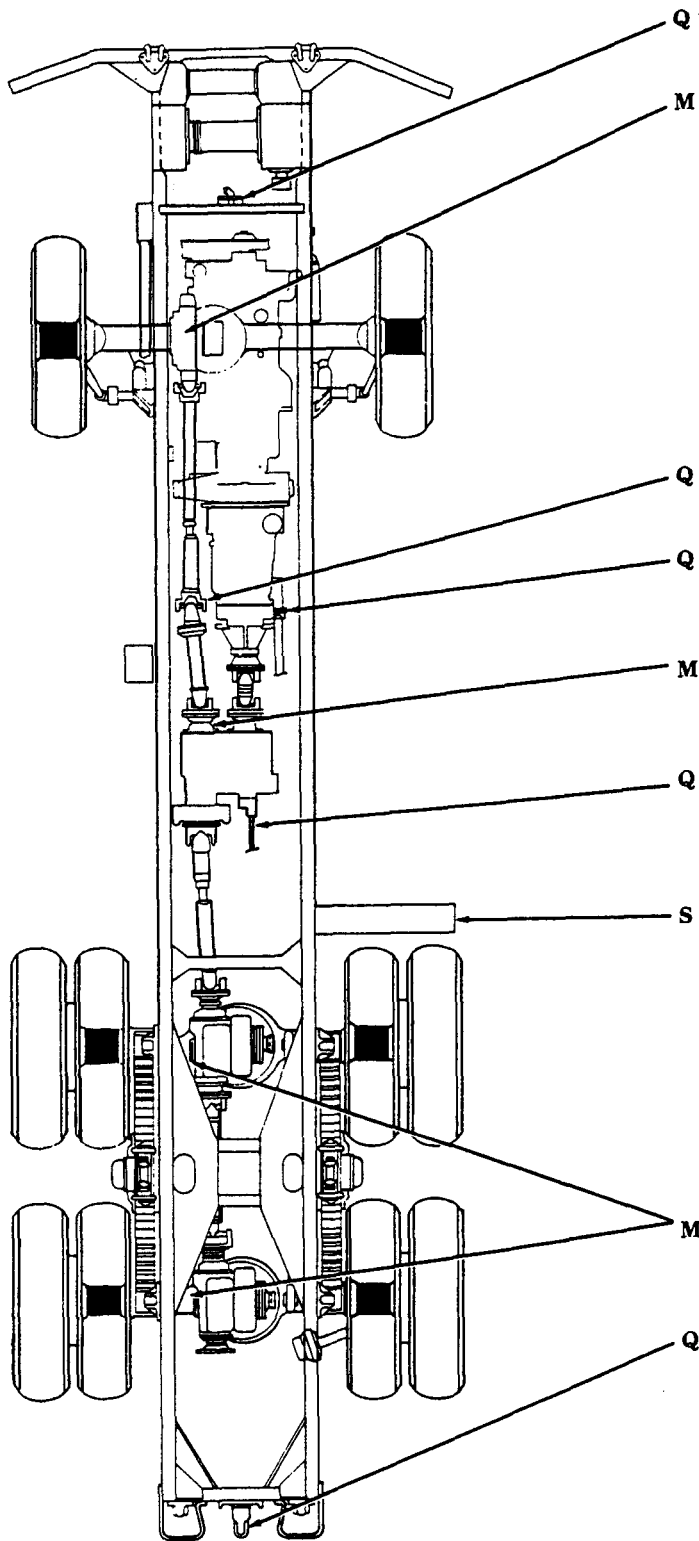

- Q** **GAA** Hood Trunnion
(1 fitting) (O)

- M** **OE/
HDO** Axle Breather
(All axles) (Keep breather
and area clean) (LV-AB) (O)

- Q** **GAA** Universal and Slip Joint
(See note 8) (LV-X, Y) (O)
- Q** **GAA** Power Takeoff Universal Joint
(Some models) (See note 8)
(LV-U, V) (O)
- M** **OE/
HDO** Transfer Case Shift
Linkage Pins
(See note 15) (LV-Z) (O)
- Q** **GAA** Power Takeoff Universal
and Slip Joint
(Some models) (See note 8)
(LV-X, Y) (O)
- S** **OE/
HDO** Winch Reservoir
(Fill to top notch on
dipstick) (See key, card 2) (C)

- M** **OE/
HDO** Axle Breather
(All axles) (Keep breather
and area clean) (LV-AB) (O)

- Q** **GAA** Towing Pintle
(3 fittings) (LV-AA) (O)

TA 350540

INTERVAL • LUBRICANT

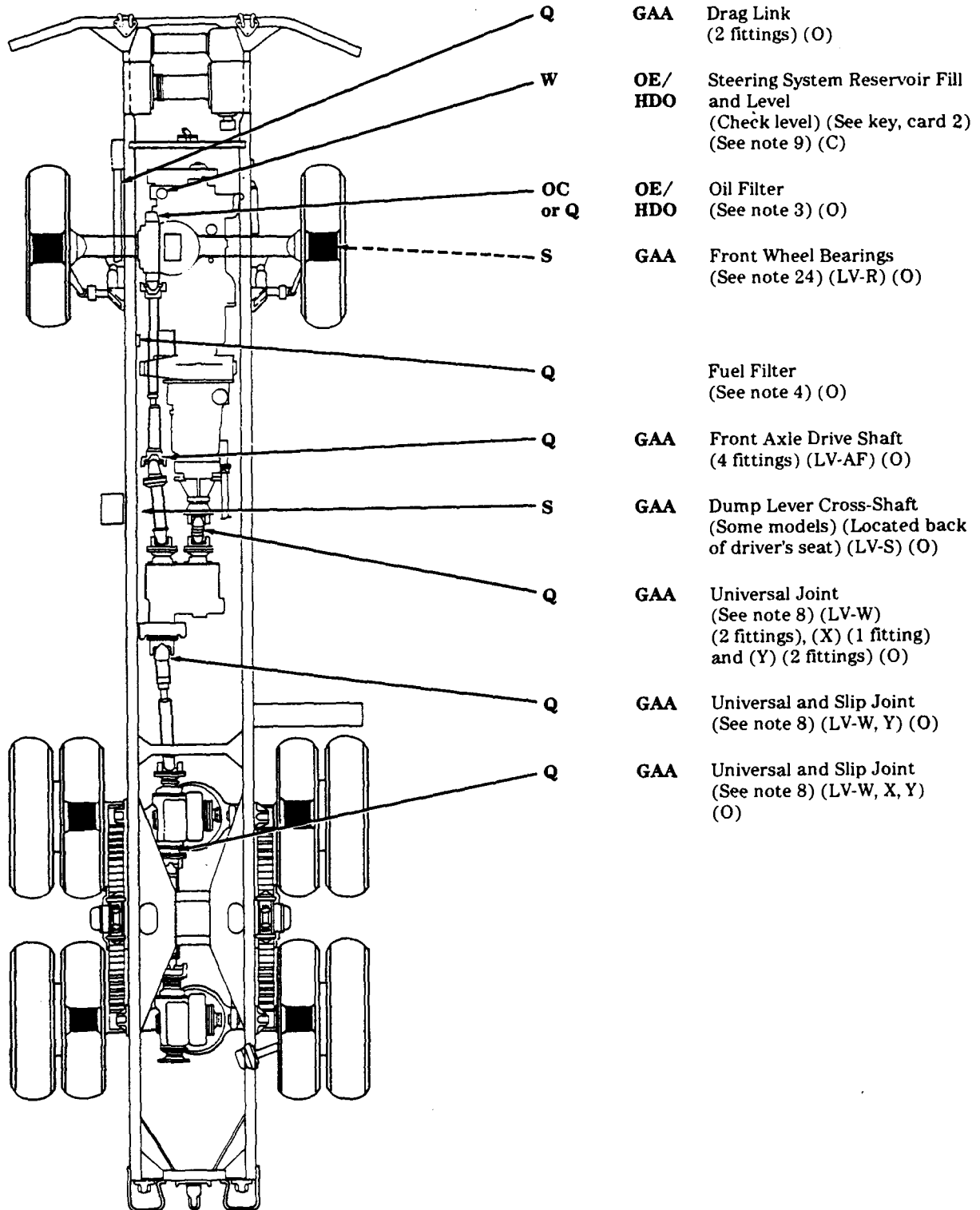

TA 350541

INTERVAL • LUBRICANT

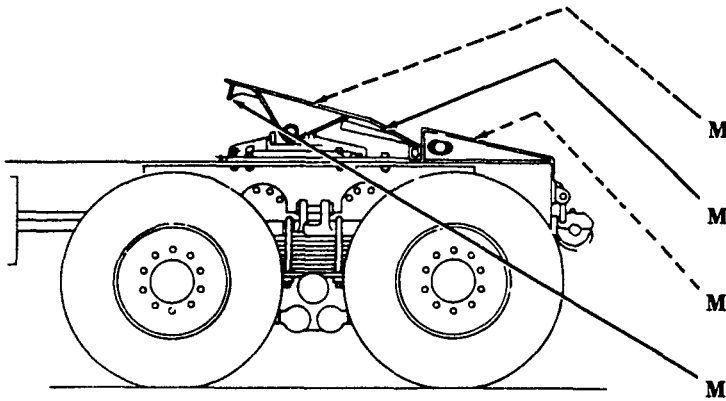

FIFTH WHEEL —
M931, M931A1, M931A2, M932, M932A1, M932A2
(LEFT SIDE VIEW)

- M GAA Base Plate (Grease Well) (LV-AK) (C)
- M GAA Base Plate (Clean and coat) (C)
- M GAA Approach Plate (Clean and coat) (C)
- M OE/HDO Lock Plunger Shaft (LV-AL)(O)

LUBRICANT • INTERVAL

- Bushing Pin (2 fittings) (LV-AH) (O)
- Coupler Jaw Pin (LV-AJ) (O)
- Walking Beam (2 fittings) (LV-AG) (O)

- GAA M
- GAA M
- GAA M

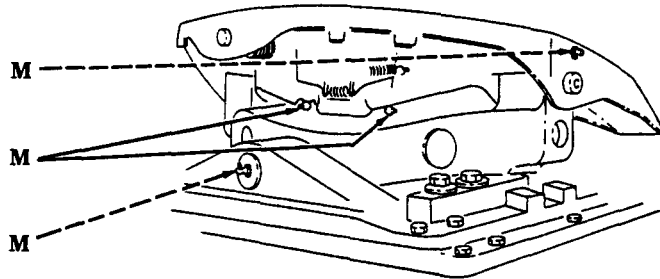

FIFTH WHEEL —
M931, M931A1, M931A2, M932, M932A1, M932A2

INTERVAL • LUBRICANT

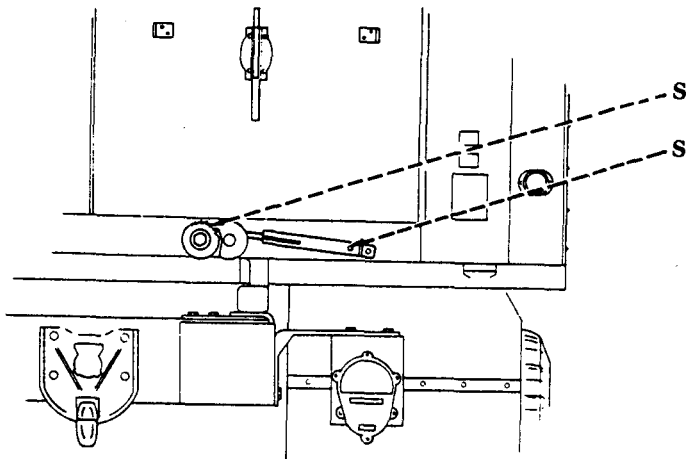

VAN BODY —
M934, M943A1, M934A2, M935, M935A1, M935A2
(REAR VIEW)

- S GAA Ratchet (O)
- S GAA Pawl Plunger (O)

TA 350542

INTERVAL • LUBRICANT

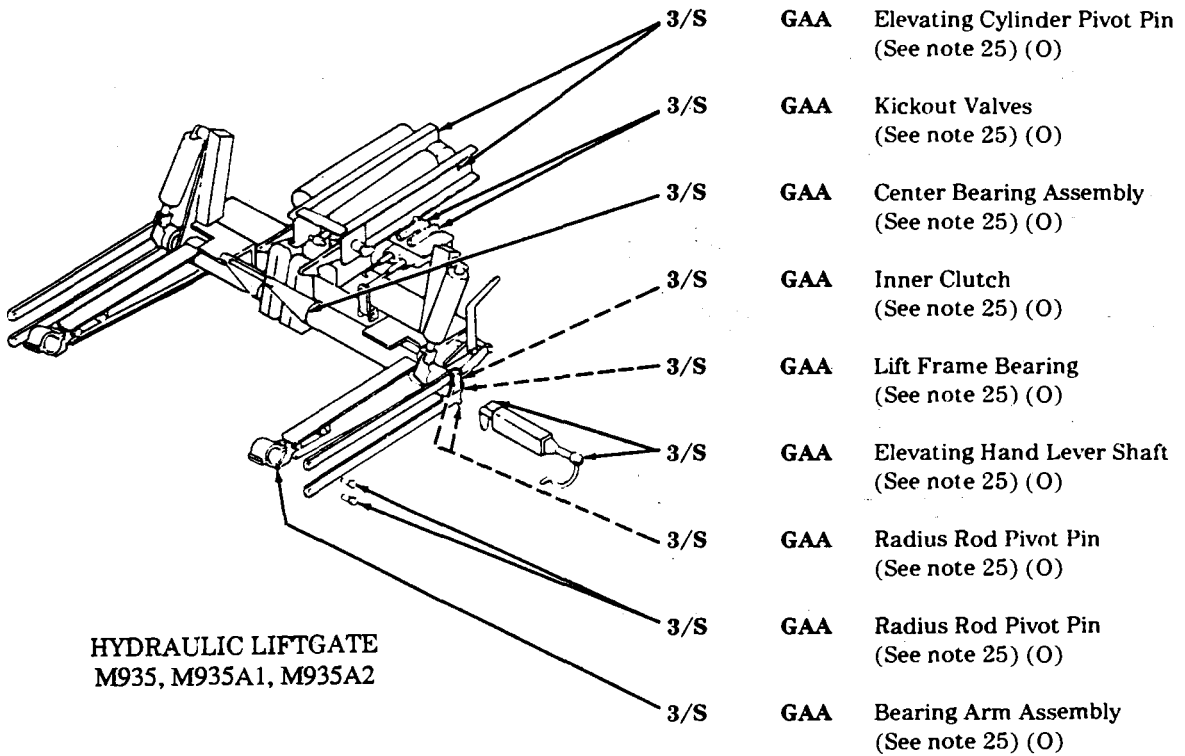

**HYDRAULIC LIFTGATE
M935, M935A1, M935A2**

LUBRICANT • INTERVAL

Hydraulic Oil Reservoir Fill and Level (See key, card 2) (See note 20) (O)	OE/ HDO
Elevating Hand Lever Shaft. (See note 25) (O)	GAA
Center Bearing Assembly (See note 25) (O)	GAA
Radius Rod Pivot Pin (See note 25) (O)	GAA
Bearing Arm Assembly (See note 25) (O)	GAA
Hydraulic Pump Universal Joint (See note 25) (O)	GAA
Power Takeoff Universal Joint (See note 25) (O)	GAA

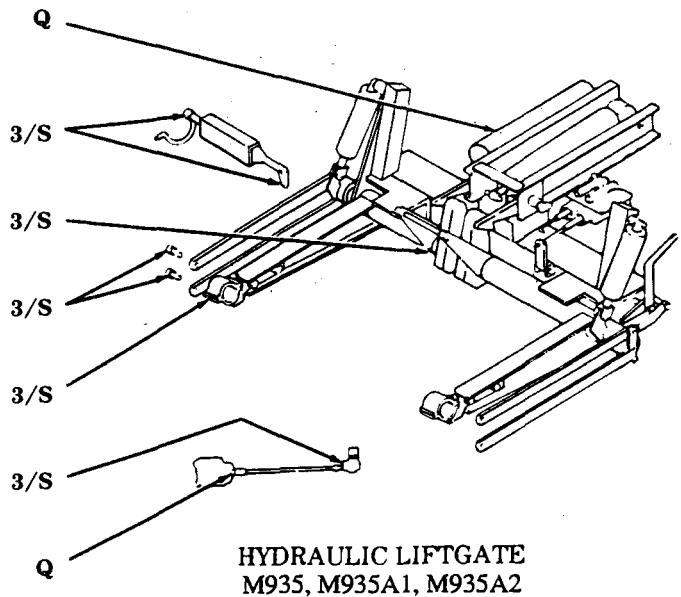

**HYDRAULIC LIFTGATE
M935, M935A1, M935A2**

TA 350543

INTERVAL • LUBRICANT

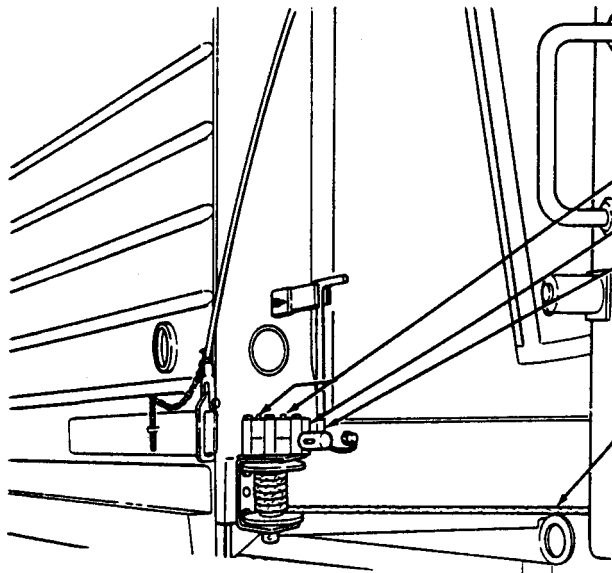

**VAN BODY - M934A1, M935A1, M935A2
(LEFT SIDE VIEW)**

- GW** Worm Gear Fill (O)
- GW** Worm Fill (O)
- GW** Winch Handle Shaft Fill (O)
- GW** Wire Rope (C)

LUBRICANT • INTERVAL

**Winch Barrel Shaft
Fill (O)**

GW

A

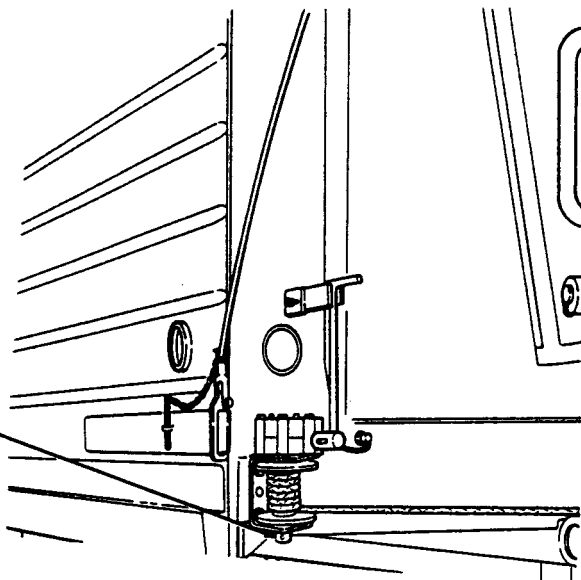

**VAN BODY - M934A1, M935A1, M935A2
(LEFT SIDE VIEW)**

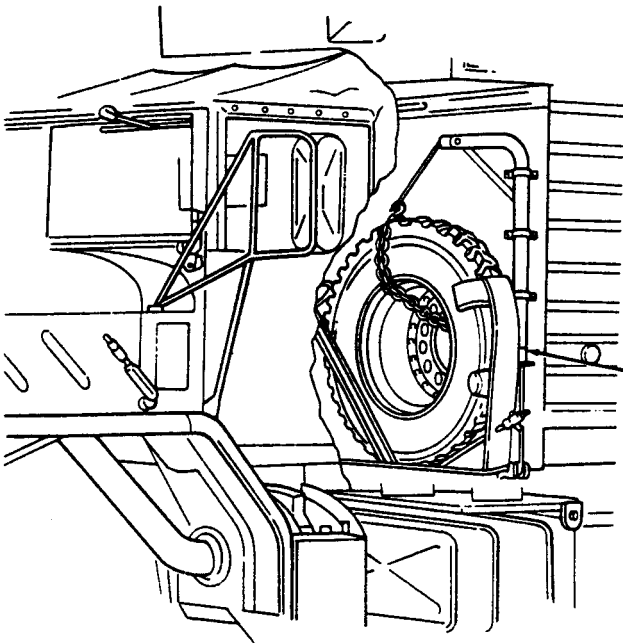

**VAN BODY - M934A1, M935A1, M935A2
(RIGHT SIDE VIEW)**

INTERVAL • LUBRICANT

- GW** Swing Davit Base (See note 27) (O)

TA 350544

INTERVAL • LUBRICANT

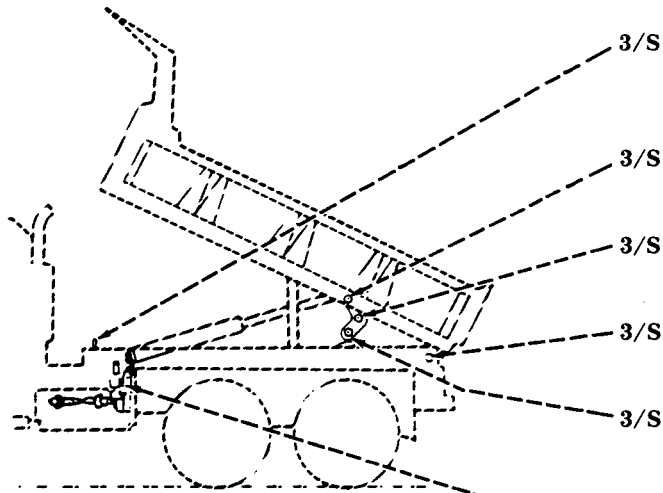

DUMP BODY —
M929, M929A1, M929A2, M930, M930A1, M930A2
(LEFT SIDE VIEW)

- GAA** Safety Latch
(2 fittings) (See note 25)
(LV-AS) (O)
- GAA** Lifting Arm
(See note 25) (LV-AN) (O)
- GAA** Cylinder Crosshead
(See note 25) (LV-AP) (O)
- GAA** Body Hinge Pins
(See note 25) (LV-AR) (O)
- GAA** Lifting Arm Rollers
(3 fittings) (See note 25)
(LV-AQ) (O)
- GAA** Trunnion Pins
(See note 25) (LV-AM) (O)

LUBRICANT • INTERVAL

Hydraulic Oil Reservoir Fill
and Level
(Check level) (See key,
card 2) (See note 14)
(LV-AT) (O)

**OE/
HDO**

Universal and Slip Joints
(See note 8) (LV-W, Y) (O)

GAA

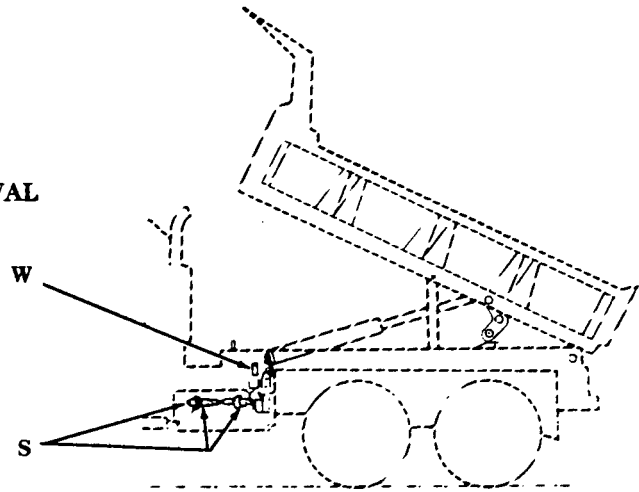

DUMP BODY —
M929, M929A1, M929A2, M930, M930A1, M930A2
(LEFT SIDE VIEW)

INTERVAL • LUBRICANT

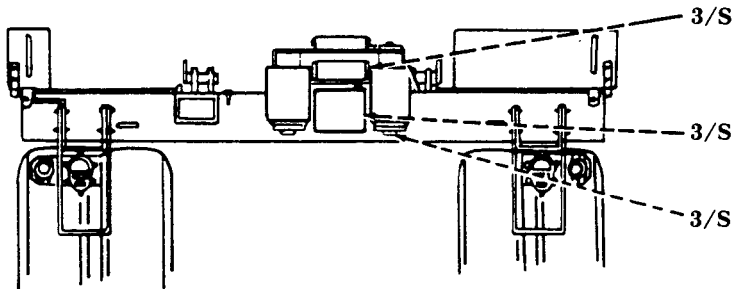

WRECKER BODY — M936, M936A1, M936A2
(REAR VIEW)

- GAA** Upper Cable Guide Roller
(2 fittings) (See note 25)
(LV-AV) (O)
- GAA** Lower Cable Guide Roller
(2 fittings) (See note 25) (O)
- GAA** Vertical Cable Guide Roller
(4 fittings) (See note 25)
(LV-AU) (O)

TA 350545

INTERVAL • LUBRICANT

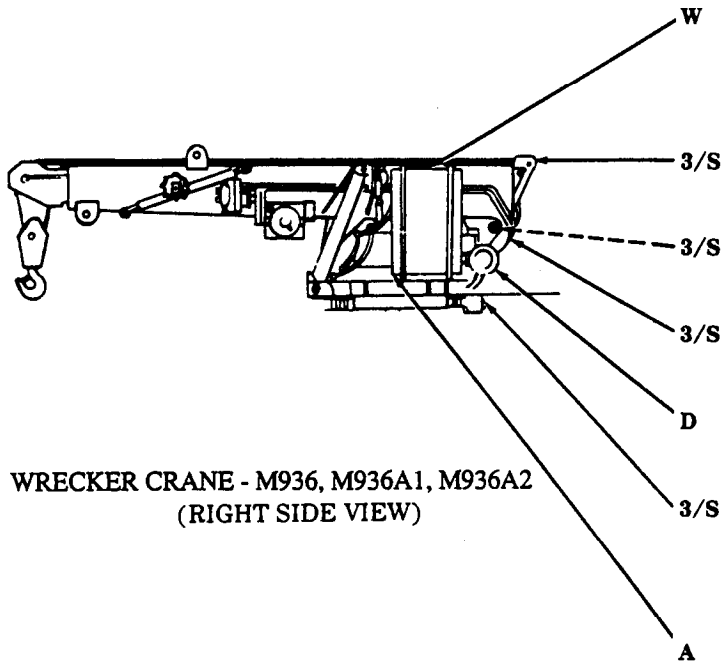

- OE/
HDO** Hydraulic Oil Reservoir
Fill and Level
(Check level) (See key, card 2)
(See note 13) (LV-AW) (O)
- GAA** Hoist Cable Sheave
(See note 12) (O)
- GAA** Boom Hinge Pin
(See note 25) (LV-AX) (O)
- GAA** Hoist Cable Sheave
(See note 12) (O)
- OE/
HDO** Hydraulic System Filter
(See note 19) (O)
- GO** Swinger Gearcase Fill
and Level
(Check level) (See key, card 2)
(See note 6) (LV-BA, BB) (O)
- OE/
HDO** Hydraulic Oil Reservoir Drain
(Drain and refill) (See
note 13) (LV-AZ) (O)

LUBRICANT • INTERVAL

- GO** Hoist Gearcase Fill
(See key, card 2)
(See note 11) (O)
- GAA** Boom Cylinder Pin
(See note 25) (O)
- GAA** Boom Sheave Pin
(See note 25) (O)
- CW** Hoist Cable
(See note 12) (LV-BD) (O)
- GAA** Block Sheave Pin
(See note 25) (LV-BE) (O)
- GAA** Block Hook
(See note 25) (O)
- GO** Hoist Gearcase Fill and Level
(Check level) (See key, card 2)
(See note 11) (LV-BH) (O)

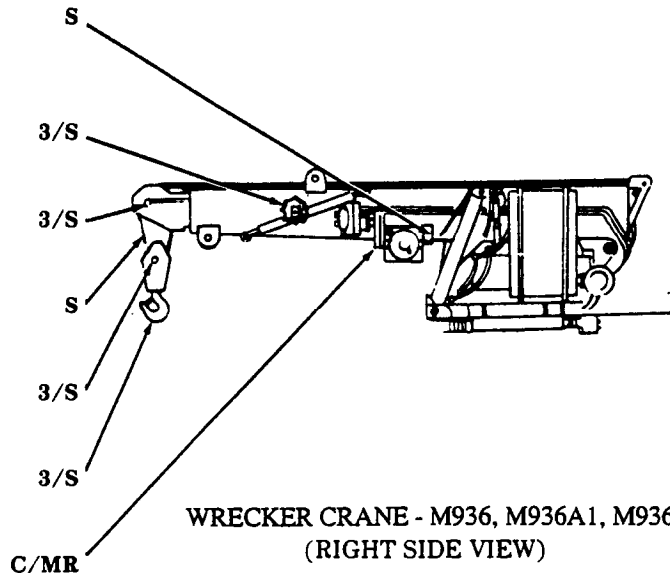

TA 350546

INTERVAL • LUBRICANT

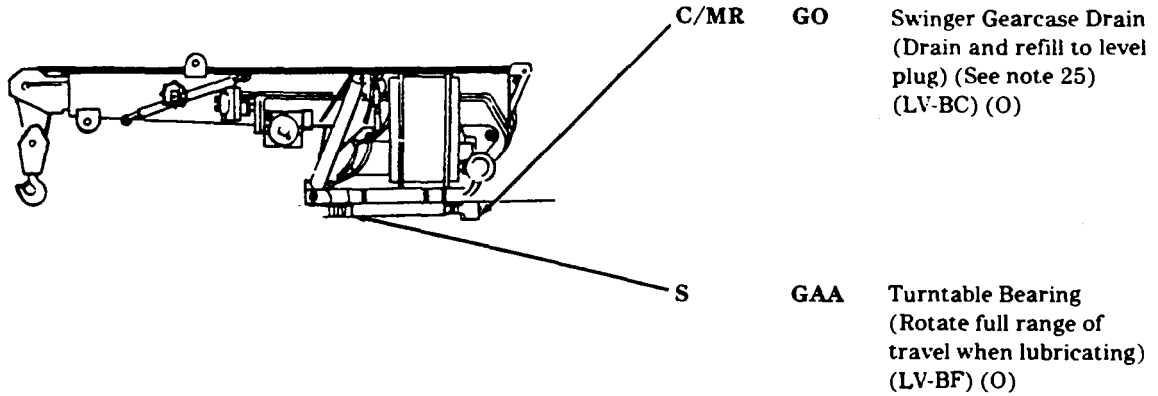

**WRECKER CRANE — M936, M936A1,
M936A2
(RIGHT SIDE VIEW)**

LUBRICANT • INTERVAL

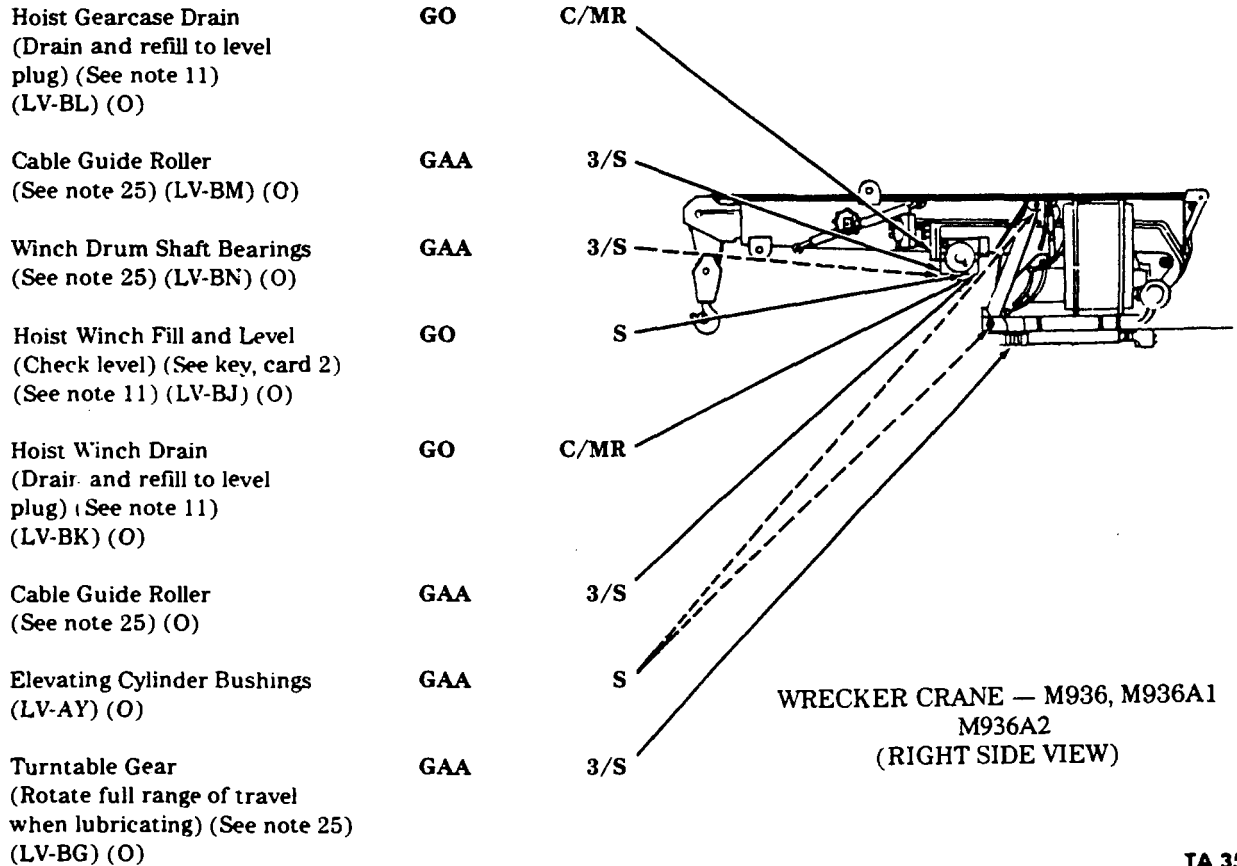

TA 350547

INTERVAL • LUBRICANT

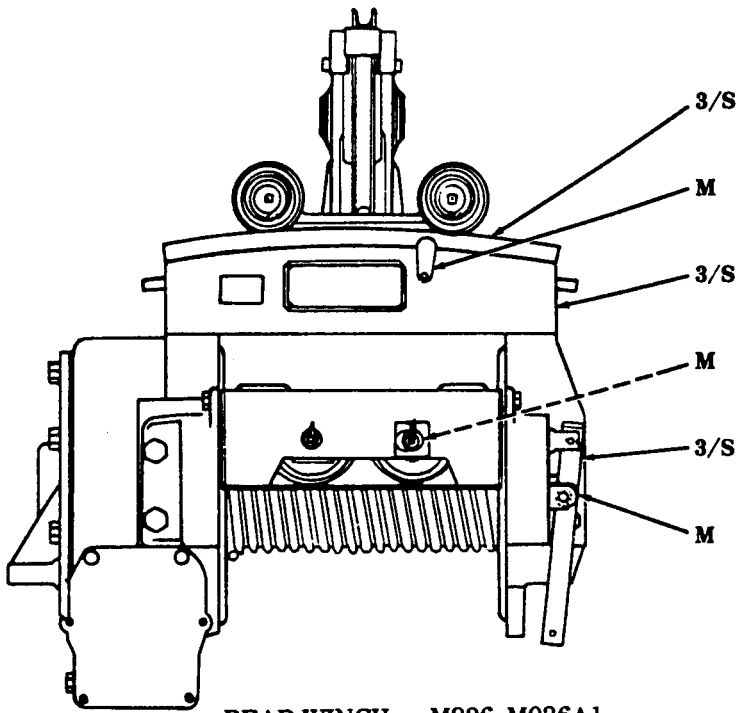

- GAA Level Wind Frame
(See note 25) (O)
- OE/
HDO Level Wind Trolley Lock
(See note 15) (O)
- GAA Sheave Frame Pin Bearing
(See note 25) (O)
- GAA Tensioner Sheave Pins
(LV-BP) (O)
- GAA End Frame Bearing
(See note 25) (LV-BS) (O)
- OE/
HDO Tensioner Rocker Lever Pins
(See note 15) (O)

REAR WINCH — M936, M936A1
M936A2
(REAR VIEW)

LUBRICANT • INTERVAL

Level Wind Sheave Bearing
(LV-BR) (O)

GAA

M

Level Wind Trolley Wheels
(LV-BQ) (O)

GAA

M

Gearcase Fill
(See key, card 2)
(See note 6) (O)

GO

C/MR

Winch Cable
(See note 12) (C)

CW

OC

Gearcase Level
(Check level) (See note 6)
(LV-BT) (O)

GO

W

Gearcase Drain
(Drain and refill to level
plug) (See note 6)
(LV-BU) (O)

GO

C/MR

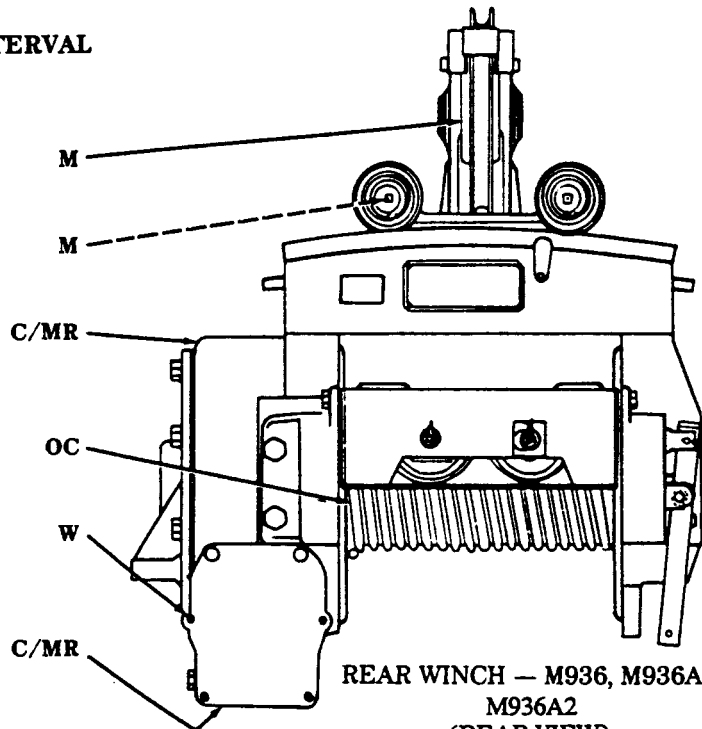

REAR WINCH — M936, M936A1
M936A2
(REAR VIEW)

TA 350548

INTERVAL • LUBRICANT

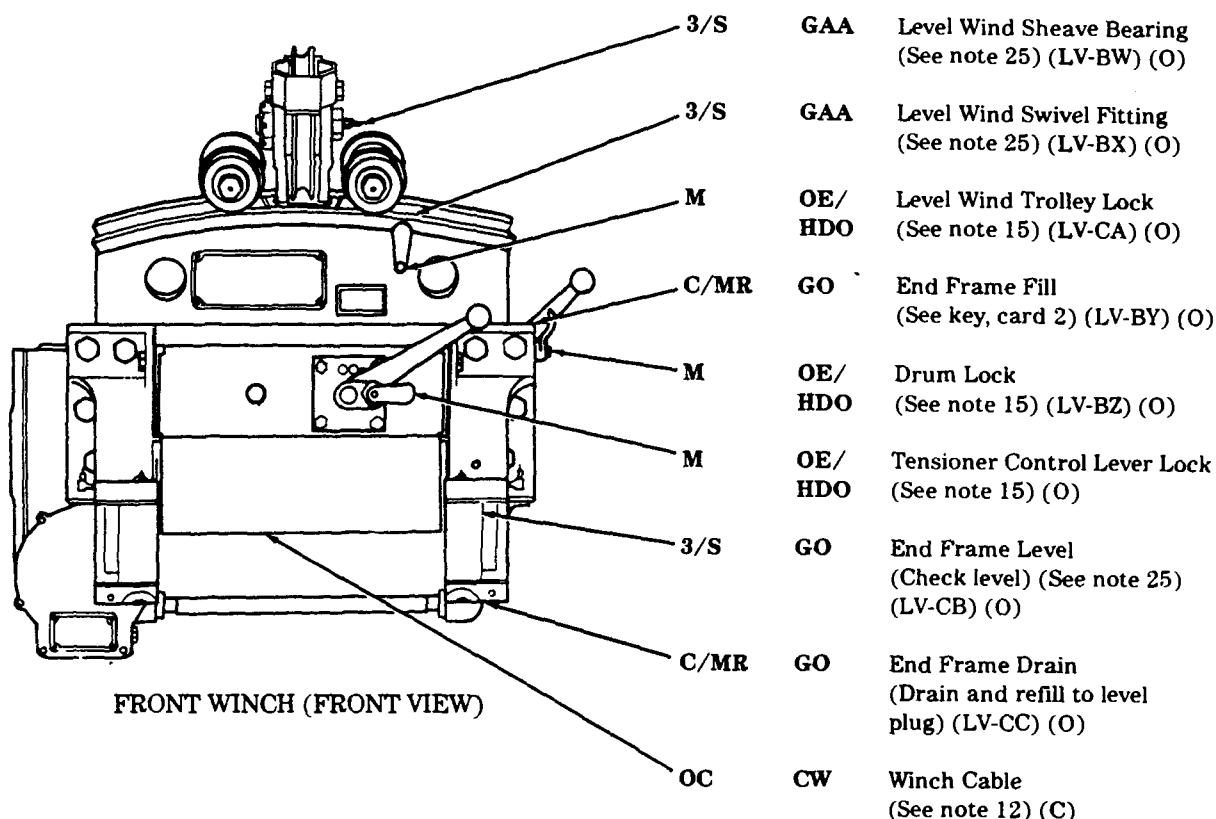

LUBRICANT • INTERVAL

- Level Wind Trolley Wheels
(2 fittings) (See note 25)
(LV-BV) (O)
- Gearcase Fill
(See key, card 2)
(See note 6) (O)
- Tensioner Sheave Pins
(2 fittings) (See note 25) (O)
- Vertical Cable Rollers
(See note 25) (O)
- Horizontal Cable Roller
(See note 25) (O)
- Gearcase Level
(Check level) (LV-CD) (O)
- Gearcase Drain
(Drain and refill to level
plug) (See note 6) (LV-CE) (O)

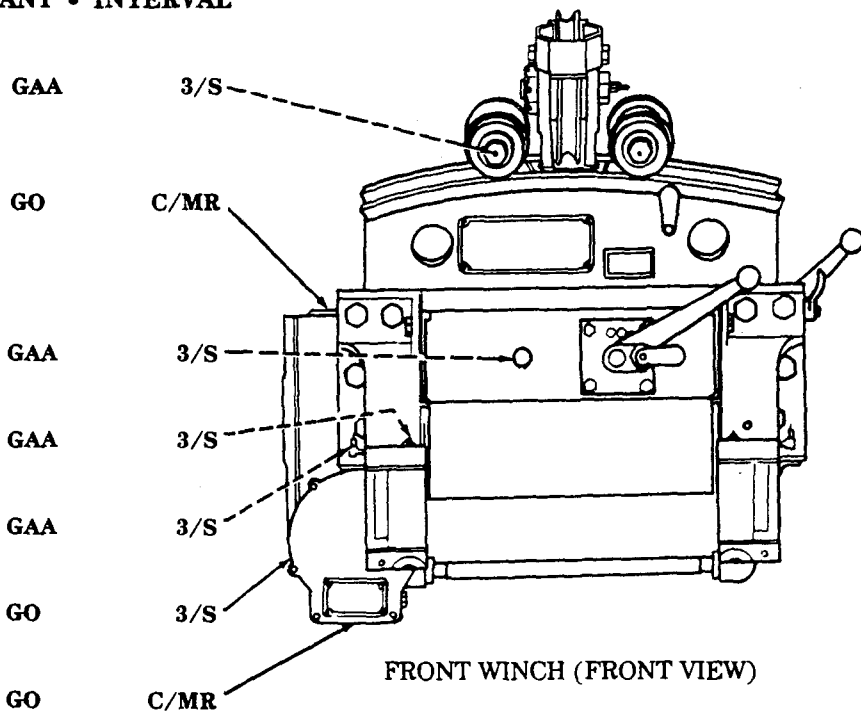

TA 350549

INTERVAL • LUBRICANT

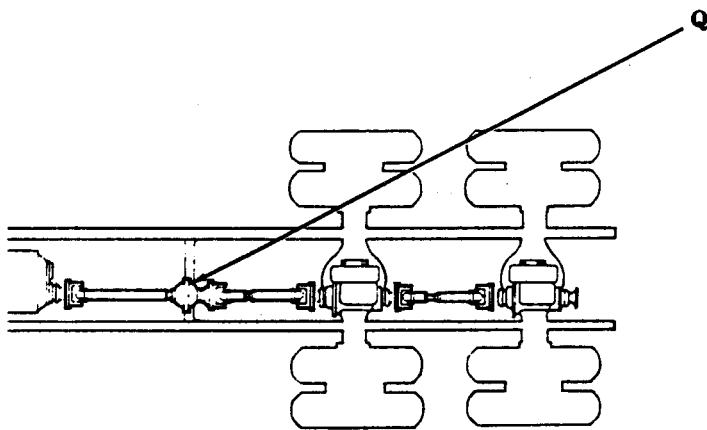

GAA Propeller Shaft Center Bearing
(See note 8) (O)

PROPELLER SHAFT CENTER BEARING —
M927, M927A1, M927A2, M928, M928A1, M928A2
M934, M934A1, M934A2, M935, M935A1, M935A2
(TOP VIEW)

TA 350550

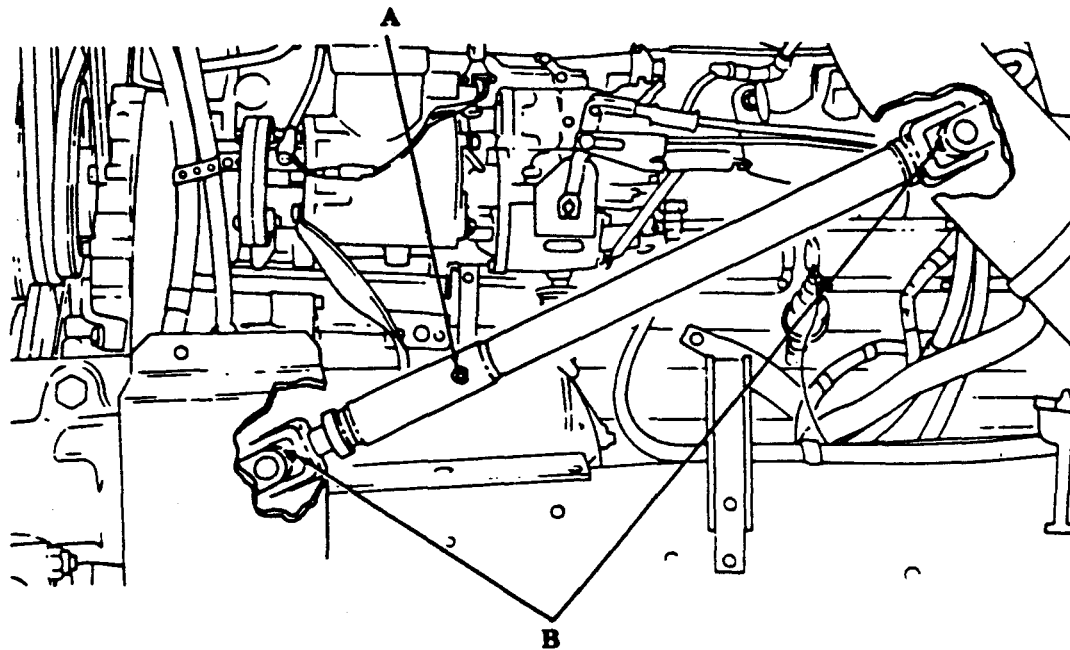

STEERING GEAR SHAFT

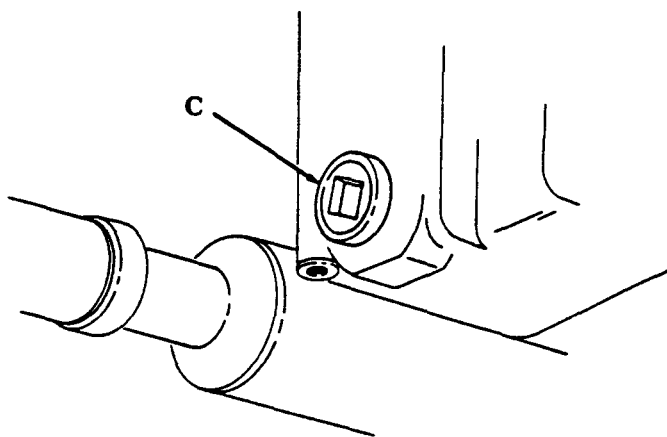

CRANKCASE DRAIN
M939 AND M939A1

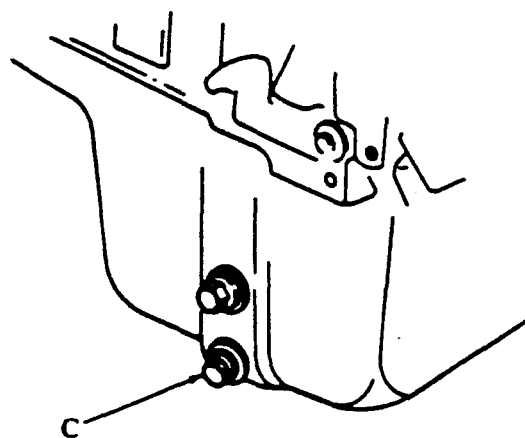

CRANKCASE DRAIN
M939A2

LOCALIZED LUBRICATION POINTS (A THROUGH C)

TA 350551

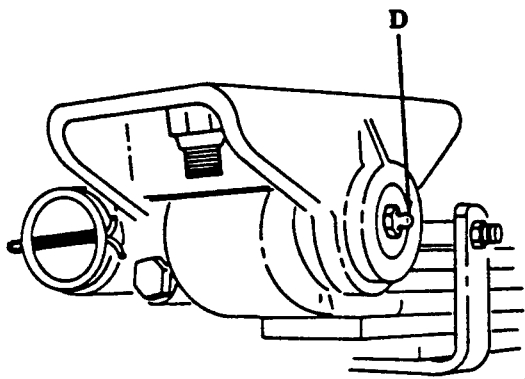

SPRING
BOLT

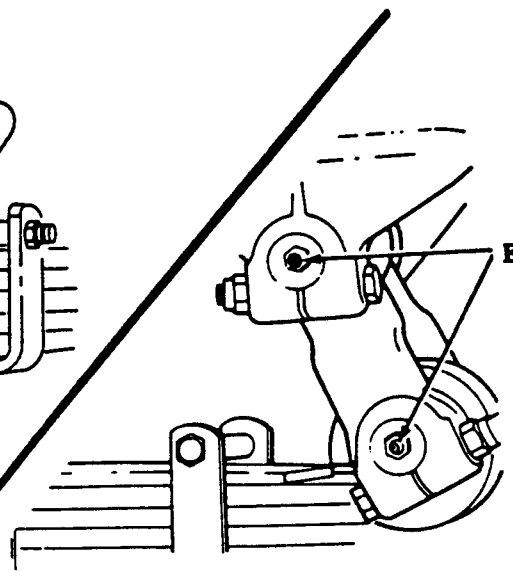

SPRING
SHACKLE

TRANSMISSION
FILL AND LEVEL

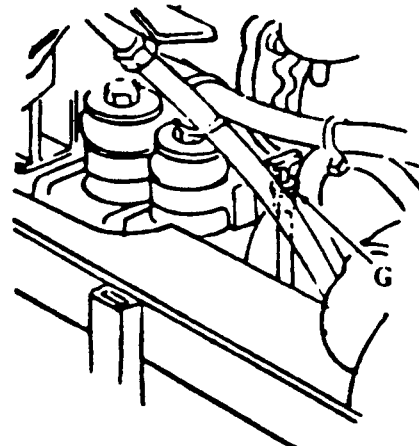

M939A2

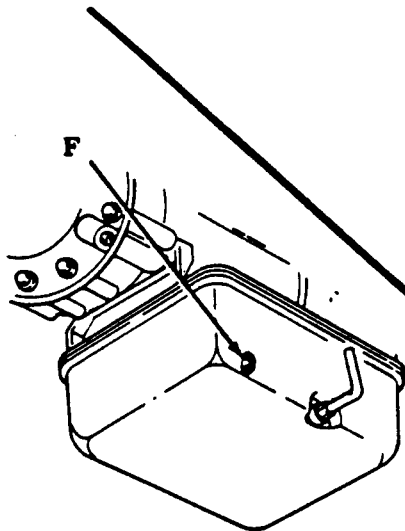

TRANSMISSION
OIL DRAIN

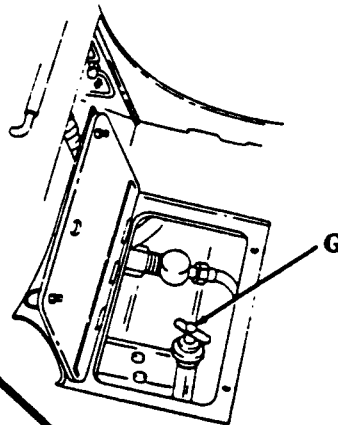

M939 AND M939A1

LOCALIZED LUBRICATION POINTS (D THROUGH G)

TA 350552

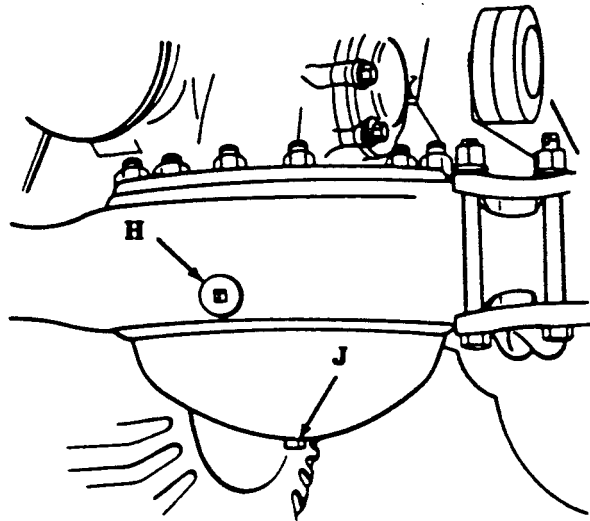

DIFFERENTIAL

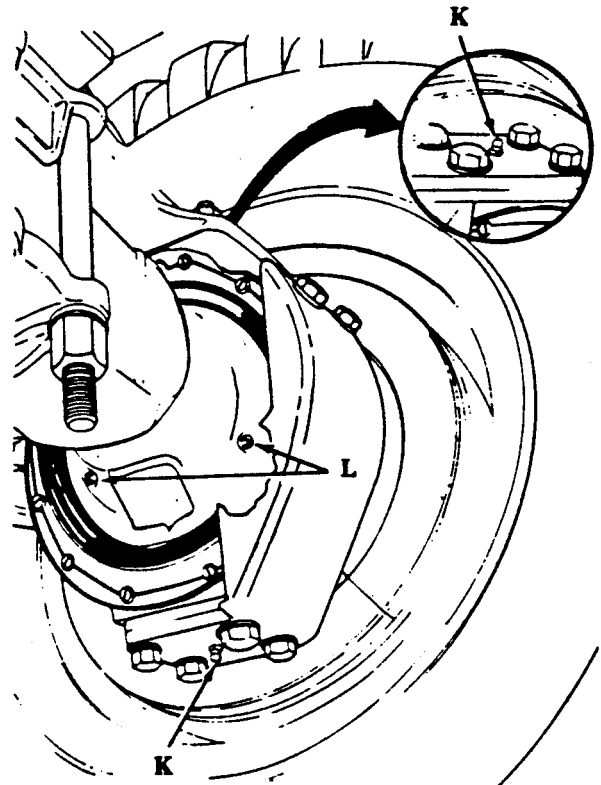

FRONT AXLE

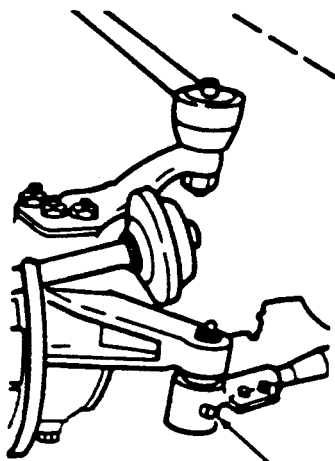

TIE ROD

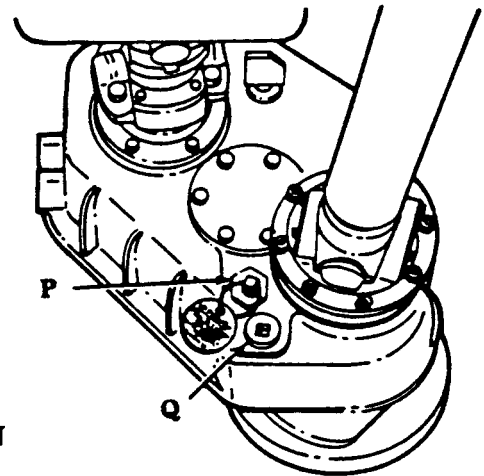

TRANSFER CASE

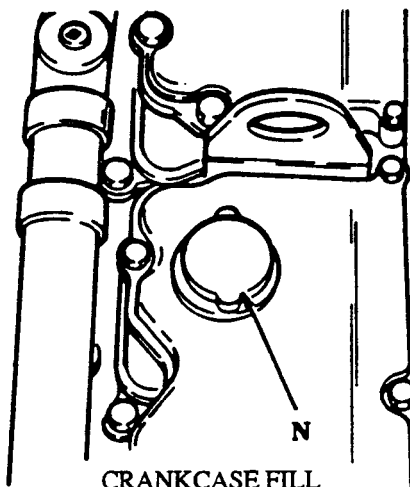

CRANKCASE FILL
M939, M939A1

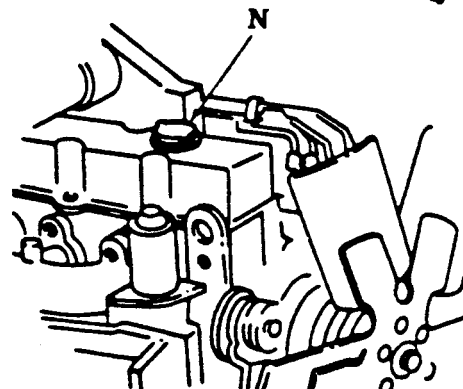

CRANKCASE FILL
M939A2

LOCALIZED LUBRICATION POINTS (H THROUGH Q)

TA 350553

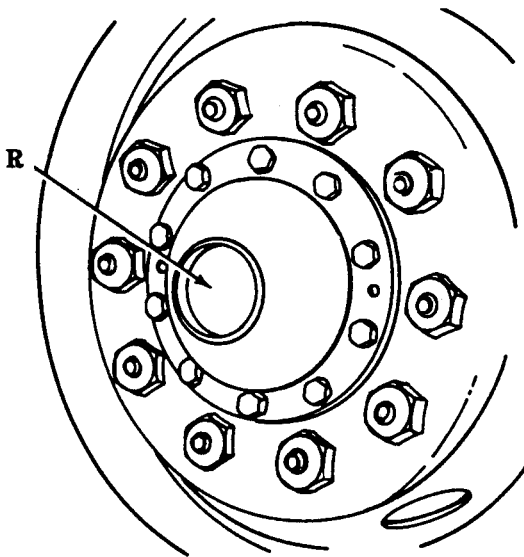

FRONT WHEEL BEARINGS

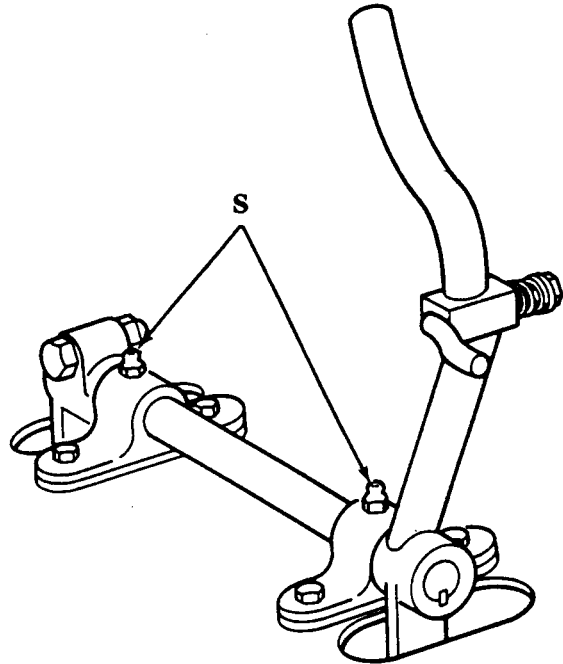

DUMP LEVER
CROSS-SHAFT

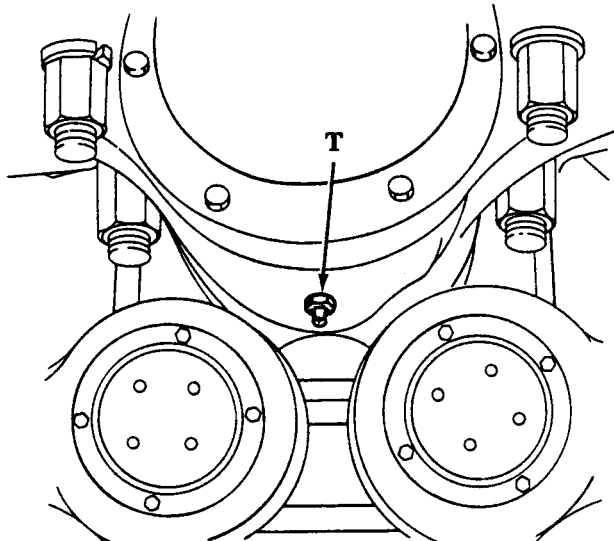

SPRING TRUNNION BEARINGS

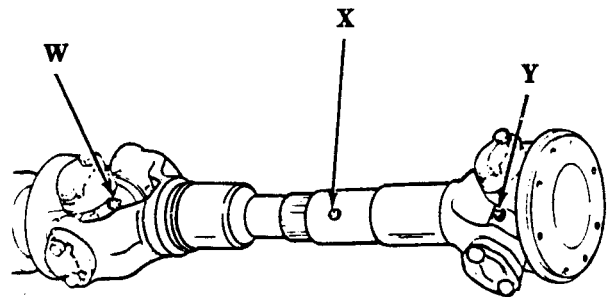

UNIVERSAL AND
SLIP JOINT

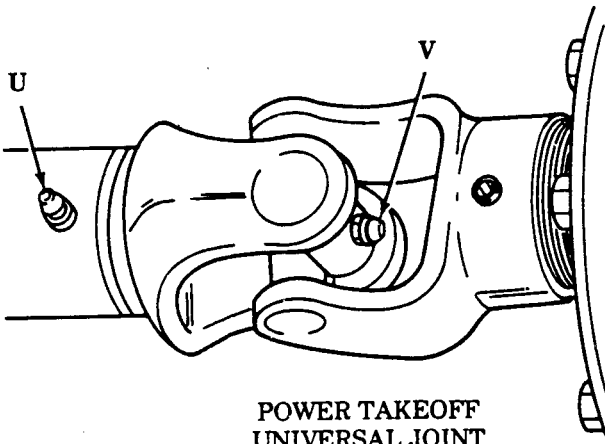

POWER TAKEOFF
UNIVERSAL JOINT

LOCALIZED LUBRICATION POINTS (R THROUGH Y)

TA 350554

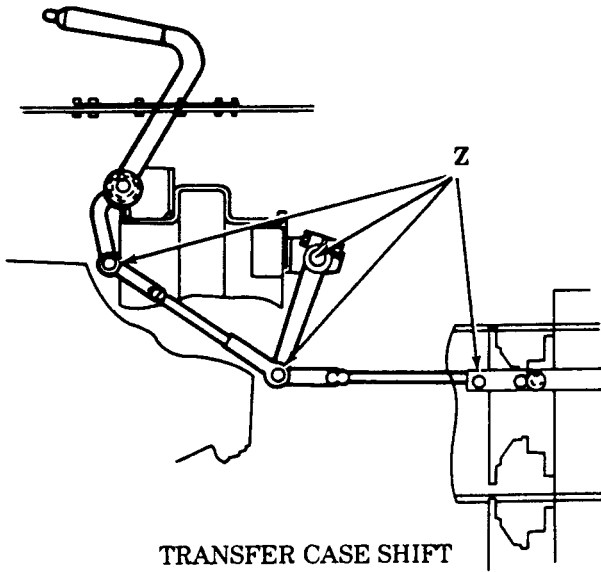

TRANSFER CASE SHIFT
LINKAGE PINS

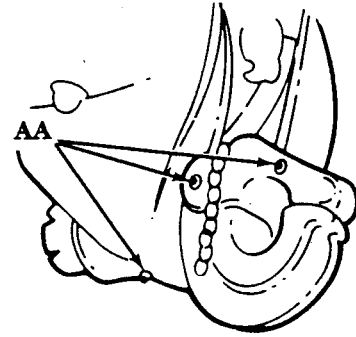

TOWING PINTLE

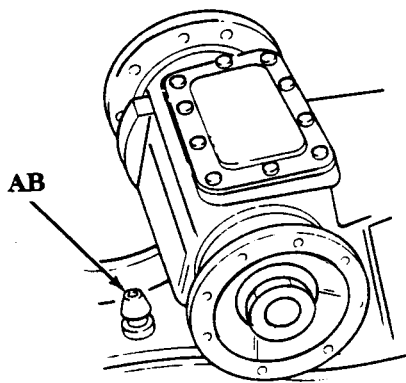

AXLE BREATHER

LOCALIZED LUBRICATION POINTS (Z THROUGH AB)

TA 350555

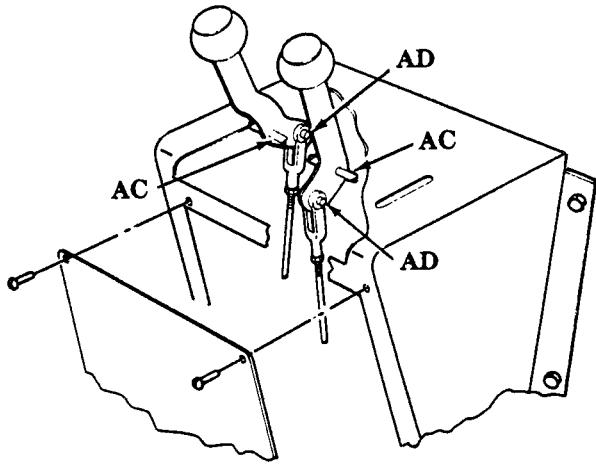

WINCH AND POWER
TAKEOFF CONTROL LEVERS

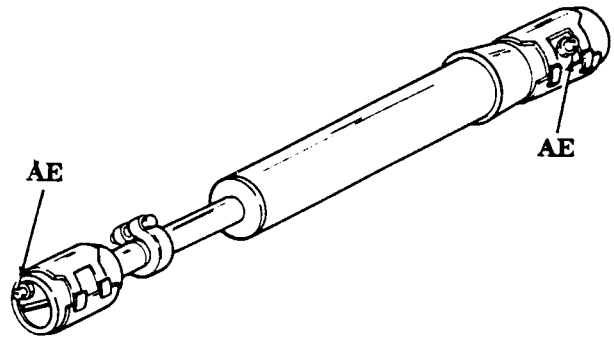

POWER STEERING
CYLINDER

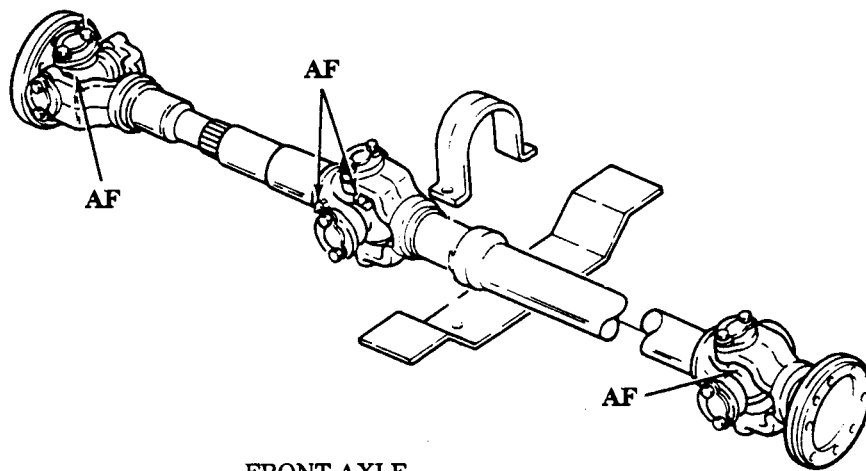

FRONT AXLE
DRIVE SHAFT

LOCALIZED LUBRICATION POINTS (AC THROUGH AF)

TA 350556

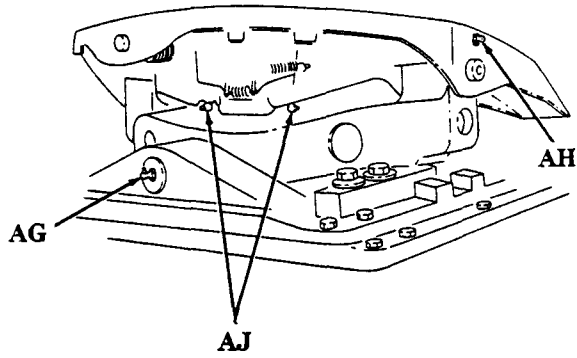

FIFTH WHEEL

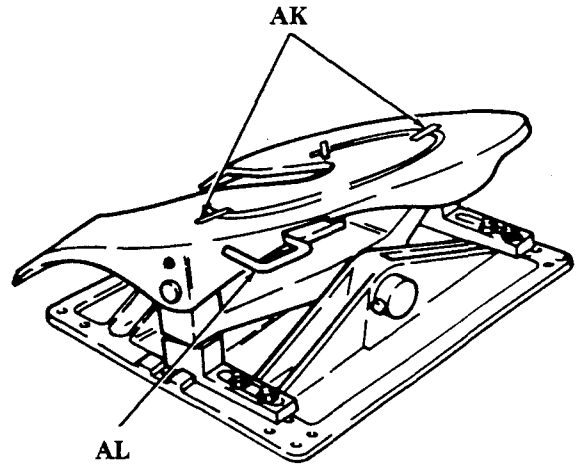

FIFTH WHEEL

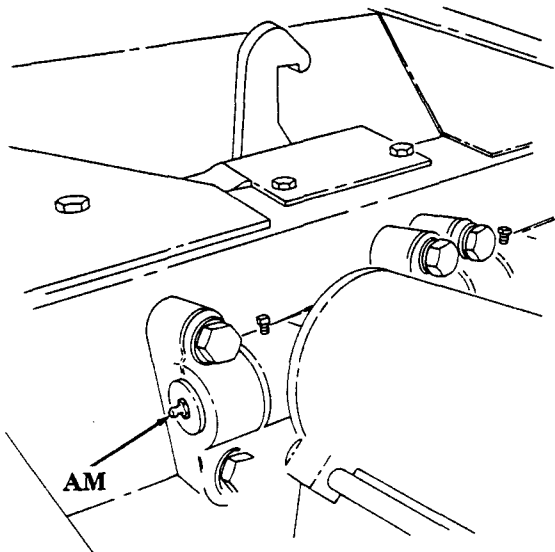

TRUNNION PIN

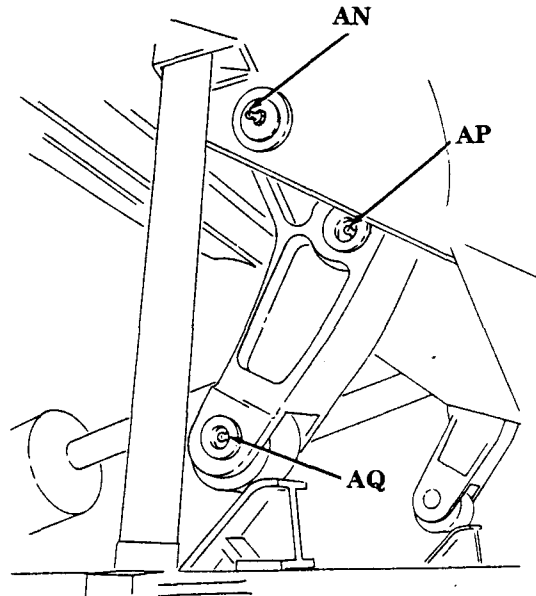

DUMP LIFTING ARM
CYLINDER CROSSHEAD
AND LIFTING ARM ROLLERS

LOCALIZED LUBRICATION POINTS (AG THROUGH AQ)

TA 350557

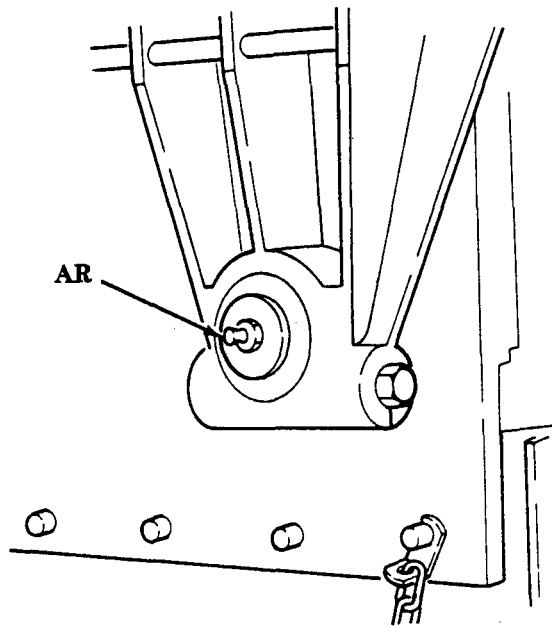

DUMP BODY HINGE PINS

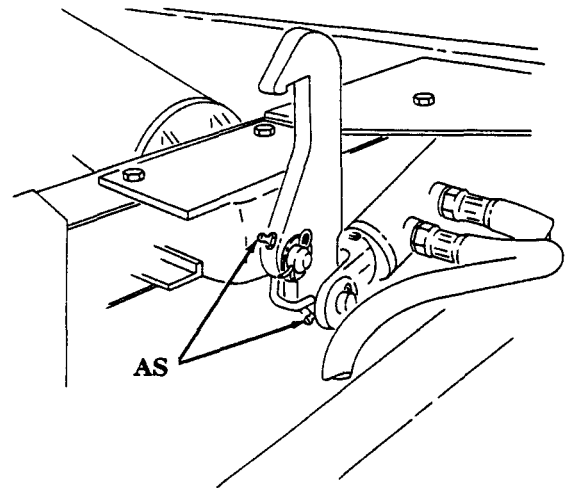

SAFETY LATCH

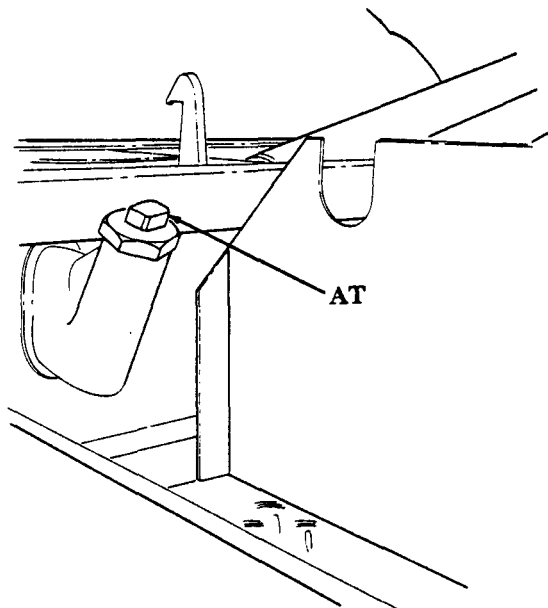

HYDRAULIC OIL RESERVOIR
FILL AND LEVEL

LOCALIZED LUBRICATION POINTS (AR THROUGH AT)

TA 350558

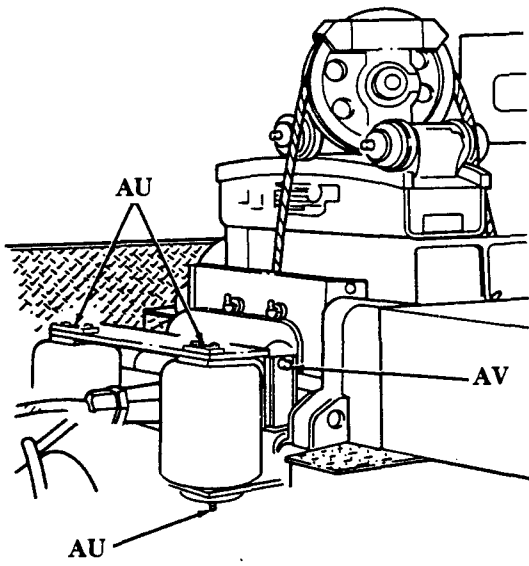

WRECKER BODY — M936, M936A1

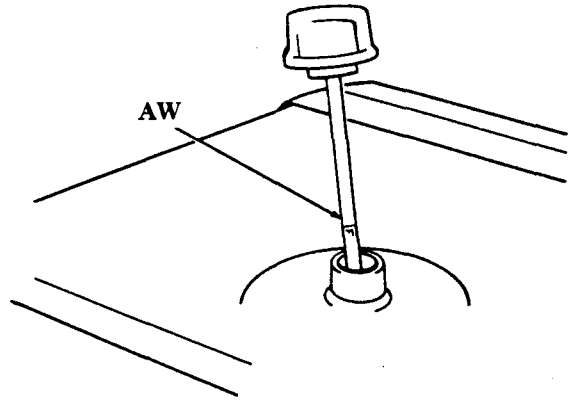

WRECKER HYDRAULIC OIL RESERVOIR

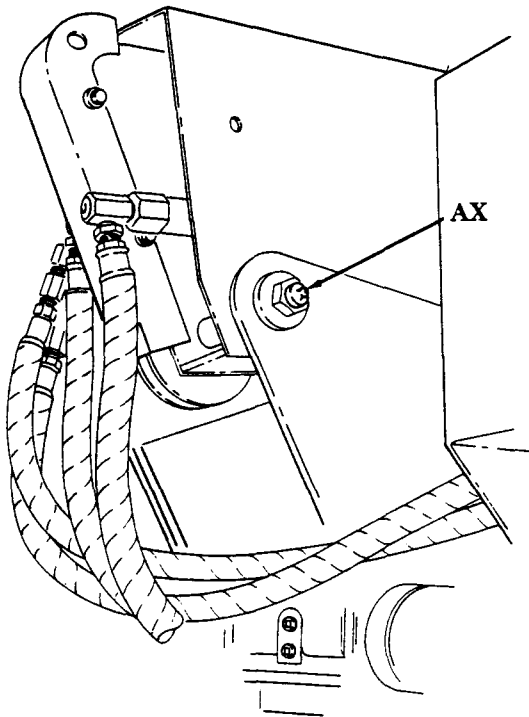

WRECKER BOOM HINGE PIN

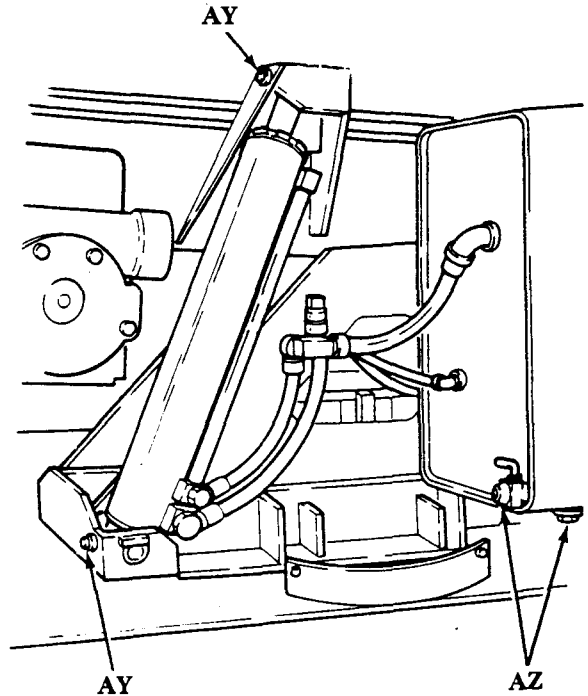

WRECKER ELEVATING CYLINDER

LOCALIZED LUBRICATION POINTS (AU THROUGH AZ)

TA 350559

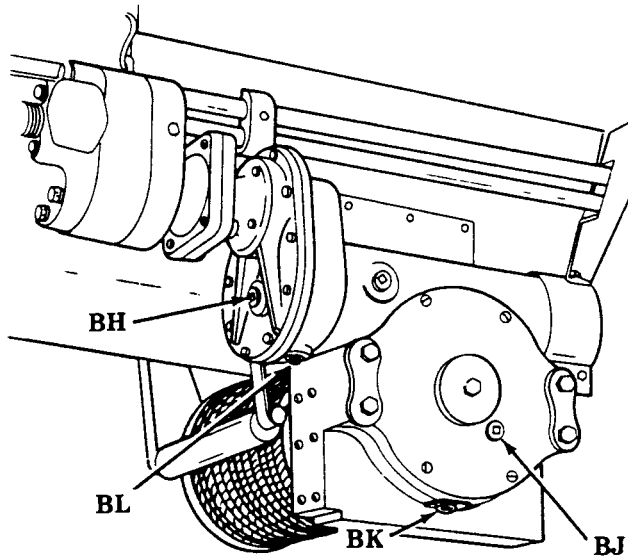

WRECKER HOIST GEARCASE
(RIGHT SIDE)

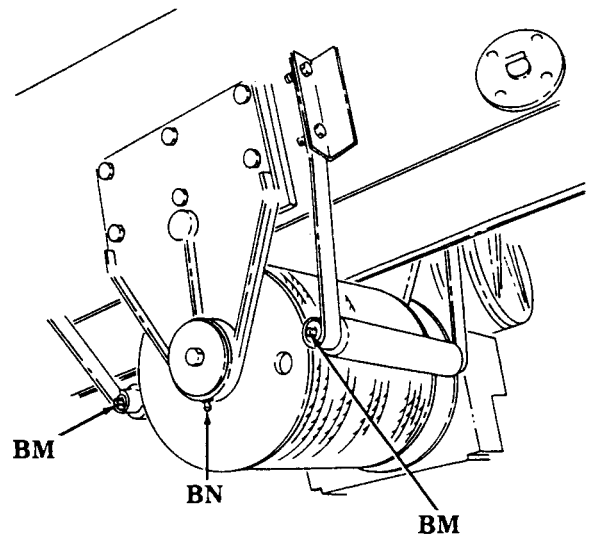

WRECKER HOIST GEARCASE
(LEFT SIDE)

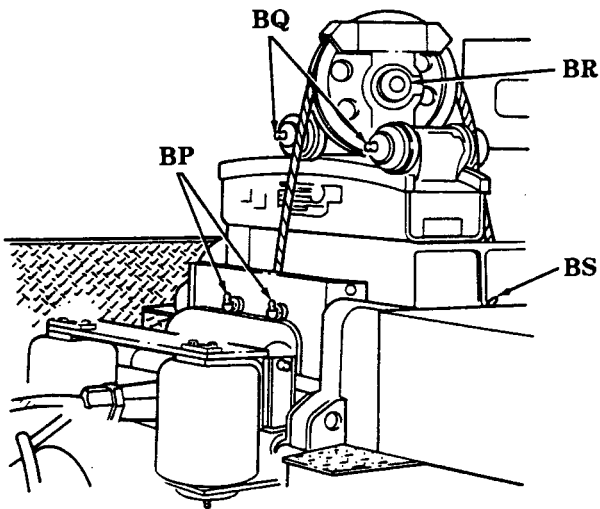

REAR WINCH — M936, M936A1

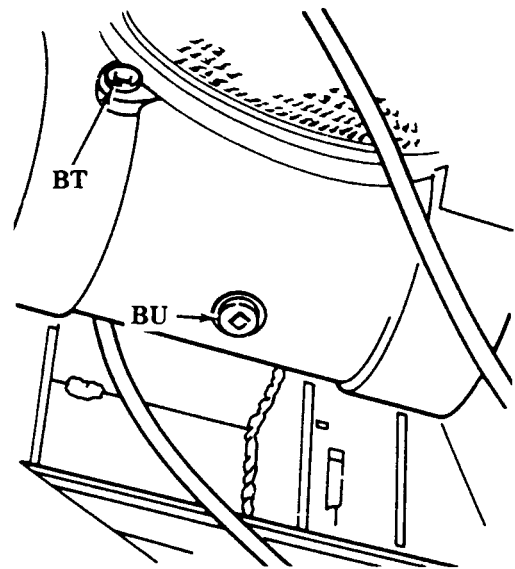

REAR WINCH GEARCASE

LOCALIZED LUBRICATION POINTS (BH THROUGH BU)

TA 350561

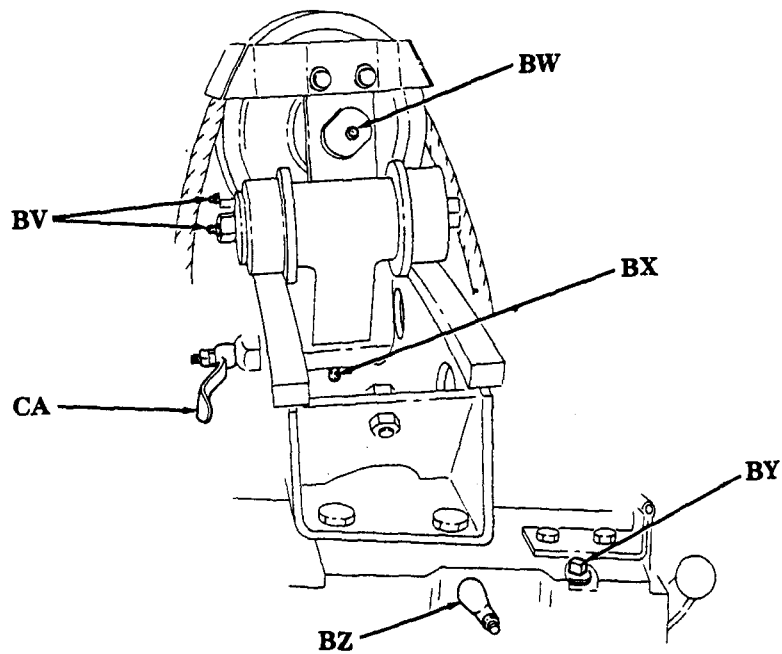

FRONT WINCH (LEFT SIDE)

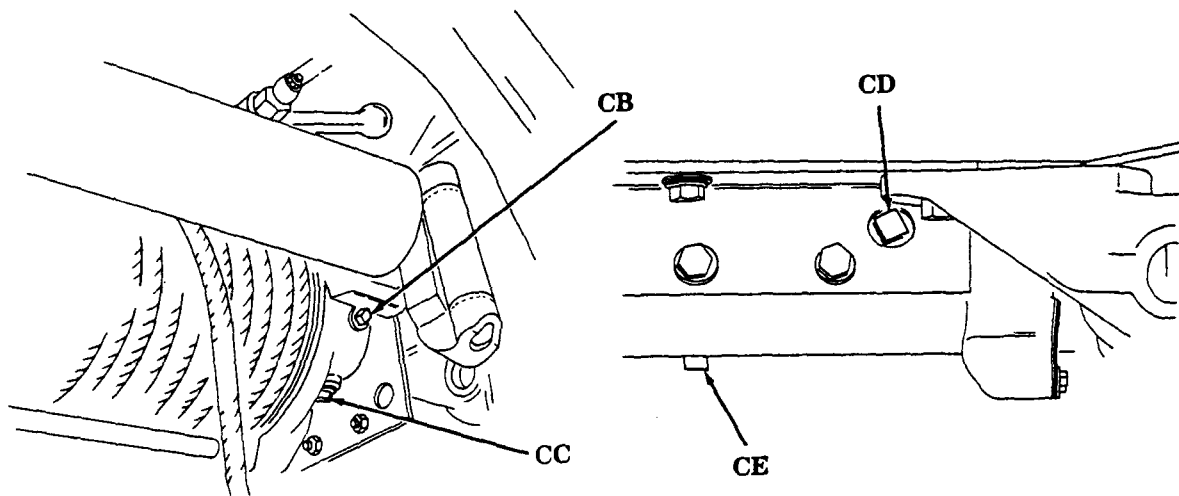

FRONT WINCH ENDFRAME

FRONT WINCH GEARCASE

LOCALIZED LUBRICATION POINTS (BV THROUGH CE)

TA 350562

NOTES

1. INTERVALS

This LO has been revised to comply with DA programing to extend intervals and conserve lubricants. When practicable, lubrication services will be made to coincide with the Vehicle "S" Preventive Maintenance Service. For this purpose, a 10% tolerance (variation) in specified lubrication point mileage is permissible.

2. CRANKCASE

CAUTION

If water or metal particles are detected during crankcase draining and filter element changing, notify Direct Support Maintenance Personnel before refilling crankcase.

NOTE

- Withdraw dipstick slowly to ensure accurate reading. There are two marks on the dipstick, H (HIGH) and L (LOW). The quantity of oil required to raise the oil level from L (LOW) mark to H (HIGH) mark is approximately 7 quarts (6.6 liters) for M939 and M939A1 and 4 quarts (3.6 liters) for the M939A2.

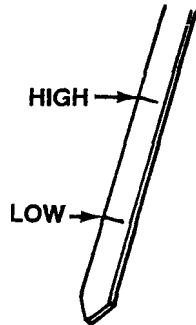

- Replace oil filter element each time crankcase is drained. Fill crankcase with engine oil.

M939 AND M939A1 SERIES VEHICLES

Crankcase Capacity	Oil Filter Capacity
23 quarts (21.8 liters)	4 quarts (3.8 liters)

M939A2 SERIES VEHICLES

Crankcase Capacity	Oil Filter Capacity
18 quarts (17 liters)	2 quarts (1.9 liters)

- Start engine and visually check for oil leaks at drain plug and oil filter case. Stop engine and allow approximately one minute for oil to drain back into oil pan; recheck oil level with dipstick. The dipstick is equipped with a seal which fits into the opening of the dipstick tube. The seal is seated within the tube and must be turned counterclockwise to be released before dipstick is withdrawn. Turn clockwise to seat after oil level has been checked and dipstick installed.
- Do not hold oil samples. Submit oil samples as soon as they have been taken.

Sample oil every 60 days or 1,000 miles (1,600 kilometers). Army Reserve Units will sample every 120 days or 1,000 miles (1,600 kilometers). Oil will be changed only when directed by oil analysis laboratory. When AOAP laboratory support is not available, change oil and filter element each 6,000 miles (9,600 kilometers) or 6 months, whichever occurs first.

Bring engine up to operating temperature and remove drain plug from oil pan. Inspect for presence of metal particles and water while draining oil into a drainage container. Allow sufficient draining time so that all oil has time to drain. Install drain plug and tighten to 60-70 lb-ft (81-95 N*m).

NOTE

Seasonal oil changes will be made due to expected temperatures. See the key on card 2.

TA. 350563 J

NOTES (Cont'd)

3. ENGINE OIL FILTER

Oil filter will be changed only when directed by oil analysis laboratory. Remove filter drain plug, drain oil, and remove filter case assembly (with element) from filter head. Remove filter element from filter case and inspect for presence of metal particles or water. Discard element after inspection has been completed. Remove seal ring from filter head and discard. Clean filter case thoroughly. Check to ensure element end seals are in place and install new element over spring support assembly. Position new seal ring on filter head with drain plug pointing down. Tighten center screw 25-35 lb-ft (34-47 N*m). When AOAP support is not available, change oil filter each 3,000 miles (4,800 kilometers) or 3 months, whichever occurs first. (Follow procedure outlined in NOTE 2.)

M939A2 series vehicle oil filters will be changed only when directed by oil analysis laboratory. Remove spin-on filter head. Drain oil from filter and observe for metal or water contamination. Discard spin-on filter. Install new spin-on filter. Tighten filter 3/4 turn after seal contacts filter head. When AOAP support is not available, change oil filter each 3,000 miles (4,800 kilometers) or 3 months, whichever occurs first. (Follow procedure outlined in NOTE 2). Look under for NOTE 4.

4. ENGINE FUEL FILTER

Replace every 3,000 miles (4,800 kilometers) or 3 months, whichever occurs first.

5. CRANKCASE BREATHER

Check crankcase breather and tube every 6,000 miles (9,600 kilometers) under normal operating conditions. When operating under unusual conditions, check crankcase breather daily. Refer to TM 9-2320-272-20-1.

6. GEARCASE

Change gear lubricant only when required by maintenance repair action, or if contaminated by water or other foreign material. Drain only after operation when hot. Place vehicle **in level position**. Remove drain and filler plugs from case. If drain plug is magnetic, check for evidence of metal particles. If bits of metal are seen, notify DS maintenance. After draining reinstall drain plugs. Fill axle differentials and transfer case within 1/2 inch (12.7 millimeters) of filler plug opening, when lubricant is cold, or to plug level when hot. Fill other gearcases to plug openings at all times, and install filler plugs. Clean vents after operation in mud or water.

7. FRONT AXLE UNIVERSAL JOINTS AND STEERING KNUCKLE BEARINGS

Every 6,000 miles (9,600 kilometers) or 6 months, whichever occurs first, disassemble and lubricate front axle shaft and universal joints. Refer to TM 9-2320-272-20-1.

8. PROPELLER SHAFT UNIVERSAL AND SLIP JOINTS

Every 3,000 miles (4,800 kilometers) or 3 months, whichever occurs first, lubricate using low pressure lubrication gun until grease is observed coming from all four trunnions. If operating conditions are severe or abnormal, service at 1,000 miles (1,600 kilometers).

9. STEERING HYDRAULIC SYSTEM

CAUTION

Do not overfill power steering reservoir. Oil will overflow into vent system on the M939A1 or thru vent capon the M939A2.

Reservoir level is checked with engine stopped. If engine is cold, fill until oil is visible on dipstick at mark designated COLD FULL. If engine has been warmed-up, fill until oil is visible at mark designated HOT FULL. The steering gear receives lubrication from the power steering pump. If oil in reservoir is contaminated, notify DS maintenance.

TA 350564

NOTES (Cont'd)

10. REAR SPRINGS TRUNNION BEARINGS

Every 3,000 miles (4,800 kilometers) or 6 months, whichever occurs first, loosen screws on bearing cap, lubricate through fitting until lubricant appears around cap, and tighten screws. Every 12,000 miles (19,000 kilometers) or 12 months, whichever occurs first, remove, clean, dry, and repack trunnion bearings.

11. M936, M936A1 AND M936A2 HOIST WINCH

Weekly, with boom in horizontal position, remove level plug from winch worm gearcase and winch input drive reduction gearcase; if level is below level plug hole, replenish to bottom of hole. Every 6 months, remove level plugs, fill plug, and drain plugs, and drain gearcases. Install drain plugs and fill to level plugs. Install level plugs and fill plug.

12. WINCH AND CRANE HOIST CABLES

Clean and oil with new OE\HDO 30 after each operation. If used infrequently or in very damp or salty conditions, lubricate with CW-II. Do not lubricate winch cable in dry, dusty conditions. Every 6 months, unwind entire cable soak and clean with new OE\HDO 30. Wipe off excess and coat cable and drum with CW before rewinding.

13. M936, M936A1 AND M936A2 CRANE HYDRAULIC OIL RESERVOIR

Weekly, with boom in horizontal position, remove oil filler cap and gage from top of reservoir. If level is below full mark on gage, replenish to full mark. Every 12,000 miles (19,000 kilometers) or 12 months, whichever occurs first, remove pipe plug from drain valve, attach hose (furnished with vehicle), and drain oil into a container. Remove plug in bottom of reservoir to completely drain. Always install plug in drain valve after draining. Refill reservoir to full mark on oil level gage (approximately 100 gallons (378.5 liters)), operate crane several times to completely fill system check level.

14. DUMP BODY HYDRAULIC OIL RESERVOIR

WARNING

Support weight of dump body on safety braces when performing maintenance on hoist mechanism with dump body in raised position.

CAUTION

Remove filler plug slowly to release pressure. Do not overfill.

Weekly, remove filler plug, gage, and screen; clean and install screen, replenish with oil to third mark from top on gage with body down in traveling position. Install gage and plug. Raise and lower body several times slowly and recheck oil level. Drain every 12 months. Remove drain plug from reservoir and drain with dump body in lowered position. Clean and install drain plug. Refill reservoir, install screen, gage, and filler plug. Raise and lower body several times slowly and recheck oil level.

15. OIL CAN POINTS

Every 1,000 miles (1,600 kilometers) or monthly, whichever occurs first, lubricate hinges and latches, transfer case and power takeoff shift linkage, parking brake lever, rear winch control lever linkage, dump truck tailgate bearings, and spare tire carrier boom roller with seasonal grade OE/HDO.

16. DO NOT LUBRICATE

Springs, alternator, water pump, or shock absorbers.

NOTES (Cont'd)

17. LUBRICATED AT TIME OF DISASSEMBLY BY DS & GS PERSONNEL

Item lubricated as part of maintenance repair procedure.

18. OPERATOR PARTICIPATION

"D" and "W" maintenance is performed by the operator. The operator will assist organizational maintenance when "M", "Q", "S", "3/S", "A", "B", "OC", and "C/MR" maintenance is performed.

19. M936, M936A1 AND M936A2 CRANE HYDRAULIC SYSTEM FILTER

CAUTION

Do not operate crane when indicator is at "BYPASSING" position.
Refer to TM 9-2320-272-20-2.

To maintain adequate filtering, remove and clean filter element when indicator points to "NEEDS CLEANING". Check indicator with pump running and oil at operating temperature. Stop engine and remove and clean filter if indicated.

20. M935, M935A1 AND M935A2 LIFTGATE HYDRAULIC OIL RESERVOIR

Every 3 months check hydraulic oil level. Place liftgate in lowered position at ground level and remove filler plug. Oil supply is minimum at 2 inches (5.1 centimeters) and maximum at 3 inches (7.6 centimeters) as indicated on dipstick.

When necessary to add oil, operate liftgate several times up and down; open and close with filler plug removed. If there is excessive oil in the system it will overflow. Replace filler plug.

21. TEMPERATURE RISES

If ambient temperature rises to +70°F (+21°C) for no more than one week, use of OE/HDO 10 is permissible. If ambient temperature rises to +30°F (-1°C) for no more than one week, use of OEA is permissible.

22. FOR OPERATION OF EQUIPMENT IN PROLONGED COLD TEMPERATURE BELOW -10° F (-23°C)

Remove lubricants prescribed in the key for temperatures above -10°F (-23°C). Clean parts with drycleaning solvent. Relubricate with lubricants specified in the key for temperatures below -10°F (-23°C).

23. TRANSMISSION

Check and fill transmission to proper level weekly.

Check oil level of automatic transmission using the following procedure:

- (1) Allow engine to idle. Shift transmission to neutral and apply parking brake.
- (2) Withdraw dipstick slowly to prevent a false reading. If transmission oil temperature gage reads 180°F (82°C) or below, level on dipstick should show between marks designated for normal run. If transmission oil temperature is above 180°F (82°C) allow transmission oil to cool.
- (3) If transmission oil level is low, add oil through filler tube. Return dipstick to filler tube, tighten dipstick handle and wipe away any oil spilled.

TA 350474

NOTES (Cont'd)

CAUTION

Do not overfill transmission. Internal transmission component damage will result.

When AOAP laboratory support is not available, change oil every 24,000 miles (38,000 kilometers) or 24 months, whichever occurs first. (Refer to TM 9-2320-272-20-2 for transmission oil filter, transmission oil cooler filter, and transmission governor filter removal and installation instructions.)

24. WHEEL BEARINGS

Every 6,000 miles (9,600 kilometers) or 6 months, whichever occurs first, remove, clean, dry, repack, and install front wheel bearings. Every 12,000 miles (19,000 kilometers) or 12 months, whichever occurs first, remove, clean, dry, repack, and install inner and outer rear wheel bearings.

25. WINCHES, CRANES, WRECKERS, DUMP BODY AND LIFTGATE

Service every 3,000 miles (4,800 kilometers) or 6 months, whichever occurs first. If operation is frequent, continuous, or under severe conditions, service weekly.

26. FRONT SPRING SHACKLES

CAUTION

Wipe fittings clean before servicing to prevent damage to shackle pins and bushings.

Every 3,000 miles (4,800 kilometers) or 3 months, whichever occurs first, lubricate with GAA until grease appears between shackle pin and bushing at both ends of spring shackle. If shackle pin does not accept GAA, remove pin. Clean and inspect shackle pin and bushing. Replace if necessary.

27. M934A1, M935A1 AND M935A2 SWING DAVIT BASE

Remove three screws and swing davit base. Lubricate inside of base and mating surface of swing davit. Install swing davit base.

Copy of this lubrication order will remain with the vehicle at all times. Instructions contained herein are mandatory and supersede all conflicting lubrication instructions dated prior to the date of this lubrication order.

BY ORDER OF THE SECRETARIES OF THE ARMY AND THE AIR FORCE:

CARL E. VUONO
General, United States Army
Chief of Staff

OFFICIAL:

THOMAS F. SIKORA
Brigadier General, United States Army
The Adjutant General

LARRY D. WELCH
General, United States Air Force
Chief of Staff

OFFICIAL:

CHARLES C. McDONALD
General, United States Air Force
Commander, Air Force Logistics Command

Distribution:

To be distributed in accordance with DA Form 12-38-E, Block 0625, Operator and Unit maintenance requirements for LO 9-2320-272-12.

TA 350475

RECOMMENDED CHANGES TO EQUIPMENT TECHNICAL PUBLICATIONS



THEN...JOT DOWN THE DOPE ABOUT IT ON THIS FORM. CAREFULLY TEAR IT OUT, FOLD IT AND DROP IT IN THE MAIL.

SOMETHING WRONG WITH PUBLICATION

FROM: (PRINT YOUR UNIT'S COMPLETE ADDRESS)

DATE SENT

PUBLICATION NUMBER

PUBLICATION DATE

PUBLICATION TITLE

BE EXACT PIN-POINT WHERE IT IS

PAGE NO.

PARA-GRAPH

FIGURE NO.

TABLE NO.

IN THIS SPACE, TELL WHAT IS WRONG AND WHAT SHOULD BE DONE ABOUT IT.

TEAR ALONG PERFORATED LINE

PRINTED NAME, GRADE OR TITLE AND TELEPHONE NUMBER

SIGN HERE

The Metric System and Equivalents

Linear Measure

1 centimeter = 10 millimeters = .39 inch
 1 decimeter = 10 centimeters = 3.94 inches
 1 meter = 10 decimeters = 39.37 inches
 1 dekameter = 10 meters = 32.8 feet
 1 hectometer = 10 dekameters = 328.08 feet
 1 kilometer = 10 hectometers = 3,280.8 feet

Weights

1 centigram = 10 milligrams = .15 grain
 1 decigram = 10 centigrams = 1.54 grains
 1 gram = 10 decigrams = .035 ounce
 1 dekagram = 10 grams = .35 ounce
 1 hectogram = 10 dekagrams = 3.52 ounces
 1 kilogram = 10 hectograms = 2.2 pounds
 1 quintal = 100 kilograms = 220.46 pounds
 1 metric ton = 10 quintals = 1.1 short tons

Liquid Measure

1 centiliter = 10 milliliters = .34 fl. ounce
 1 deciliter = 10 centiliters = 3.38 fl. ounces
 1 liter = 10 deciliters = 33.81 fl. ounces
 1 dekaliter = 10 liters = 2.64 gallons
 1 hectoliter = 10 dekaliters = 26.42 gallons
 1 kiloliter = 10 hectoliters = 264.18 gallons

Square Measure

1 sq. centimeter = 100 sq. millimeters = .155 sq. inch
 1 sq. decimeter = 100 sq. centimeters = 15.5 sq. inches
 1 sq. meter (centare) = 100 sq. decimeters = 10.76 sq. feet
 1 sq. dekameter (are) = 100 sq. meters = 1,076.4 sq. feet
 1 sq. hectometer (hectare) = 100 sq. dekameters = 2.47 acres
 1 sq. kilometer = 100 sq. hectometers = .386 sq. mile

Cubic Measure

1 cu. centimeter = 1000 cu. millimeters = .06 cu. inch
 1 cu. decimeter = 1000 cu. centimeters = 61.02 cu. inches
 1 cu. meter = 1000 cu. decimeters = 35.31 cu. feet

Approximate Conversion Factors

To change	To	Multiply by	To change	To	Multiply by
inches	centimeters	2.540	ounce-inches	newton-meters	.007062
feet	meters	.305	centimeters	inches	.394
yards	meters	.914	meters	feet	3.280
miles	kilometers	1.609	meters	yards	1.094
square inches	square centimeters	6.451	kilometers	miles	.621
square feet	square meters	.093	square centimeters	square inches	.155
square yards	square meters	.836	square meters	square feet	10.764
square miles	square kilometers	2.590	square meters	square yards	1.196
acres	square hectometers	.405	square kilometers	square miles	.386
cubic feet	cubic meters	.028	square hectometers	acres	2.471
cubic yards	cubic meters	.765	cubic meters	cubic feet	35.315
fluid ounces	milliliters	29.573	cubic meters	cubic yards	1.308
pints	liters	.473	milliliters	fluid ounces	.034
quarts	liters	.946	liters	pints	2.113
gallons	liters	3.785	liters	quarts	1.057
ounces	grams	28.349	liters	gallons	.264
pounds	kilograms	.454	grams	ounces	.035
short tons	metric tons	.907	kilograms	pounds	2.205
pound-feet	newton-meters	1.356	metric tons	short tons	1.102
pound-inches	newton-meters	.11296			

Temperature (Exact)

°F Fahrenheit temperature 5/9 (after subtracting 32) Celsius temperature °C

