

## 108. Checking, Draining, and Filling Crankcase

*a. General.* Engine crankcase is equipped with a bayonet-type oil level gage for use in checking crankcase oil level. Gage is marked FULL and LOW (fig. 91). Plug in oil pan cover (D, fig. 81) is magnetic-type and is removed to drain engine oil from crankcase. Refer to lubrication chart (par. 69) and accompanying notes for type and viscosity of oil to be used in crankcase, as well as intervals for checking and changing oil.

*b. Oil Level Gage Tube.* If oil level gage tube assembly (fig. 91) is not installed correctly, the gage may strike battery terminal when withdrawn to check crankcase oil level. This causes a short circuit. To prevent short circuit of this nature, make corrections described in (1) and (2) below.

(1) Loosen the gage tube retaining nut at oil pan; then turn tube to move upper end toward distributor. Tighten tube retaining nut.

(2) Inspect battery cable terminal; if terminal protrudes over edge of battery, loosen terminal clamp bolt and position so cable will run parallel to battery toward engine.

*c. Checking Crankcase Oil Level* (fig. 91). Check crankcase oil level when engine is thoroughly warmed up and after engine is stopped. Allow sufficient time after stopping for oil to drain back into oil pan.

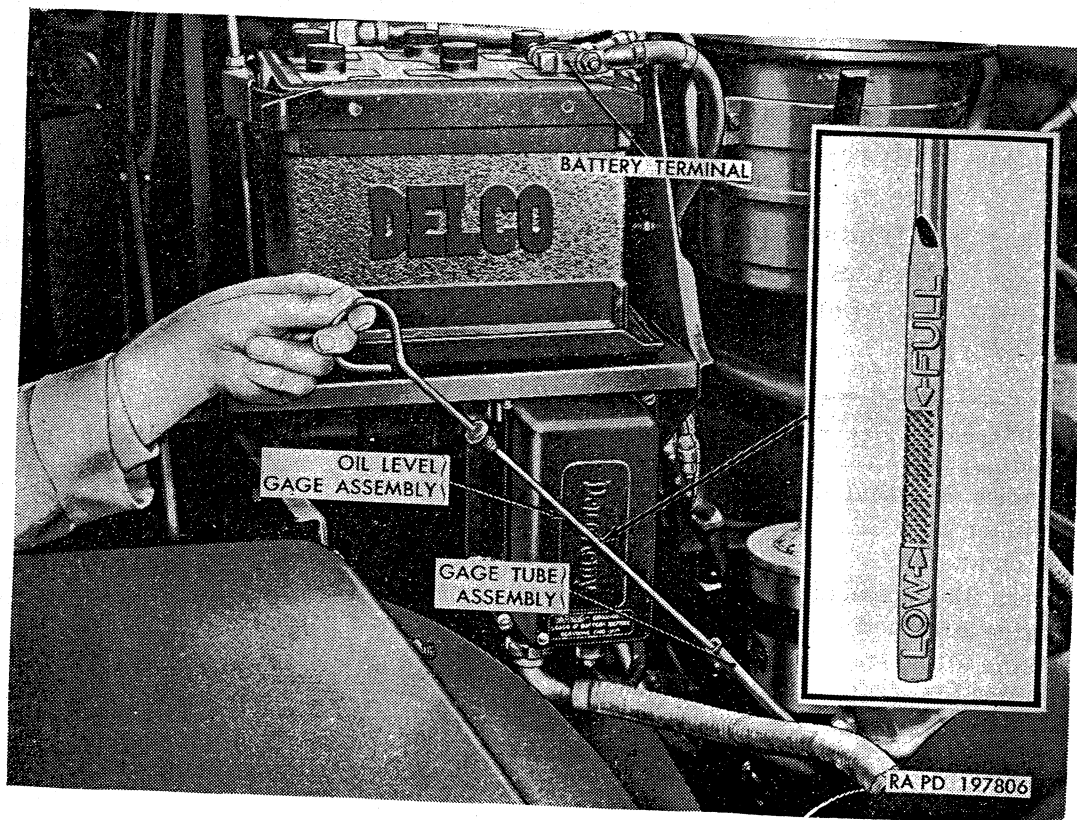

Figure 91. Checking crankcase oil level.

- oil  
ed  
g-  
er  
nd  
k-
- (1) Pull out oil level gage and wipe with clean cloth. Insert gage completely into tube; then withdraw and note oil level which must be maintained to the FULL mark. Do not operate with level below LOW mark.
  - (2) If oil level is below the FULL mark on gage, add oil through filler cap on breather as necessary to fill crankcase to FULL mark on gage.

1)  
en  
it.  
in

*d. Draining and Refilling.* Engine oil must be drained only when engine is hot after operation. The oil filter element must also be changed (par. 109) at crankcase drain periods.

- be  
n-
- (1) *Draining.* Place receptacle under engine and remove magnetic drain plug (D, fig. 81) from oil pan cover. Allow all oil to drain from oil pan. Clean drain plug to remove all metallic particles; then install drain plug and tighten.
  - (2) *Filling.* Fill crankcase with 11 quarts of engine oil. Start engine and run for a few minutes. Inspect oil filter gaskets and drain plug in filter and oil pan cover for evidence of leakage. Stop engine and check oil level, and if necessary, add oil to raise level to FULL mark on gage. Tighten plugs or replace gaskets as necessary to stop any leaks.
- er  
so

## 109. Engine Oil Filter

oil  
is  
ck

*Note.* The key letters noted in parentheses are in figure 92, except where otherwise indicated.

*a. General.* Replaceable-element-type oil filter assembly is mounted on bracket attached to right side of engine. Two band-type clamps attach filter to mounting bracket. A limited amount of engine oil enters filter through inlet line which is connected to oil gallery at left side of engine. Filtered oil returns to engine crankcase through filter outlet line installed between fitting at bottom of filter and fitting at engine crankcase. An oil filter drain plug (K) is provided at bottom of filter shell to permit draining of accumulated sediment. A new filter element must be installed whenever engine oil is drained.

### *b. Filter Element Removal.*

- (1) Remove plug from bottom of filter shell and drain completely. Unscrew filter cover locking screw (P). Remove cover assembly and gasket. Remove and discard element. Discard gasket.
- (2) Clean inside of filter shell with a rag soaked in dry-cleaning solvent or volatile mineral spirits. Remove all oil. Wipe dry.



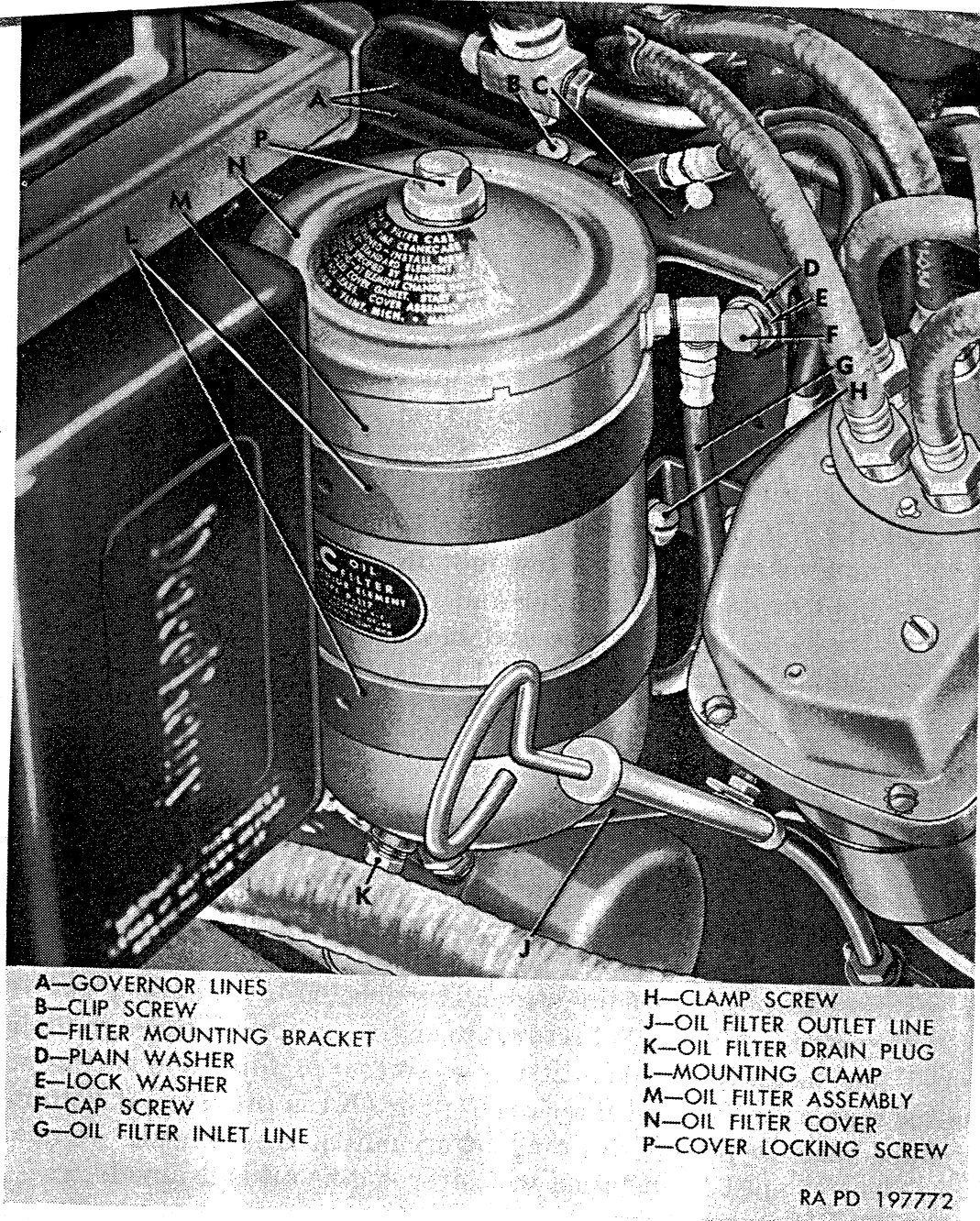

Figure 92. Engine oil filter installed.

c. *Filter Element Installation.*

- (1) Set new element in place on stud, which is welded in oil filter's shell (E, fig. 93). Install cover assembly, using new gasket. Tighten locking screw into stud.

*Note.* Spring installed on lower end of locking screw must be in place and in good condition to hold element firmly in shell.

- (2) Start engine and operate for a few minutes. Stop engine and check oil level (par. 108c). Replenish to FULL mark on gage.

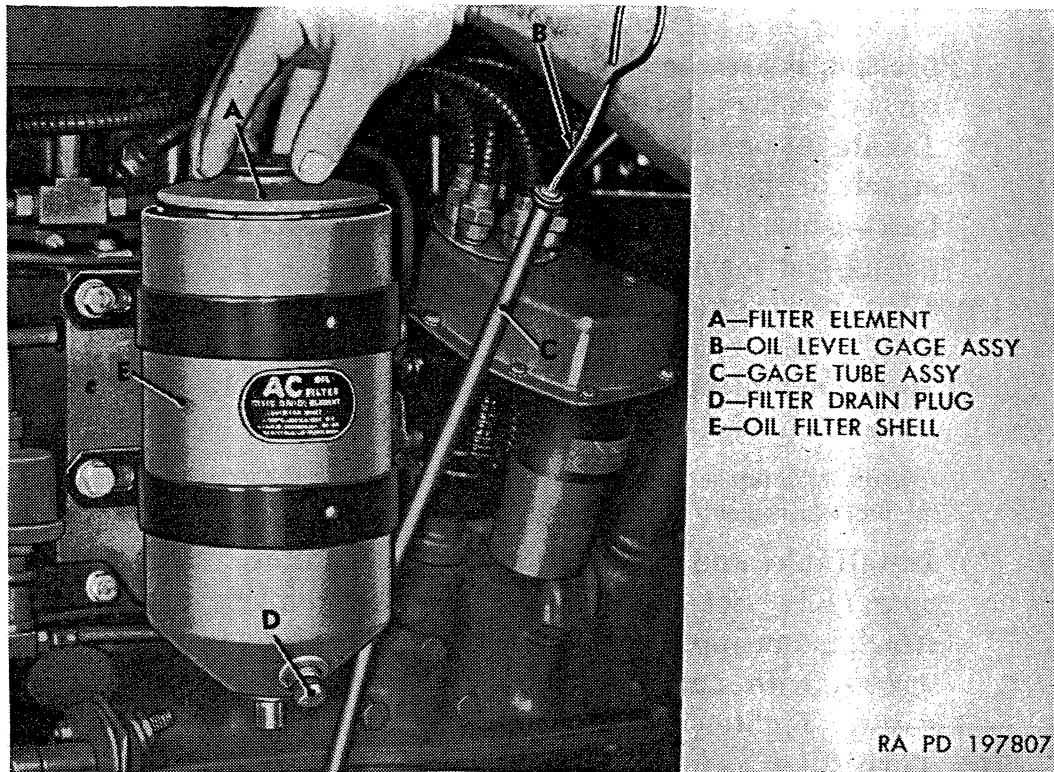

Figure 93. Installing engine oil filter element.

d. Oil Filter Assembly Removal.

- (1) Remove oil filter drain plug (K) from filter shell and drain out oil.
- (2) Disconnect inlet and outlet oil lines (G and J) at fittings on oil filter, and remove elbow sittings.
- (3) Remove four filter mounting cap screws (F) and washers; then remove filter and mounting clamp assembly from engine.
- (4) To remove mounting clamps (L) from filter assembly, loosen clamp screws (H) and slide clamps off lower end of filter shell. Remove fittings from filter shell.
- (5) To remove oil filter mounting bracket (C), remove two bracket-to-cylinder block bolts and washers at lower edge of bracket. One bolt also holds oil pressure sending unit bracket, and on early vehicles, the other bolt holds oil level gage tube bracket. Remove governor line clip screw (B) at top of bracket. Remove two screws at top of bracket which attach bracket and push rod cover to cylinder head. Remove bracket from engine.

e. Oil Filter Assembly Installation.

- (1) Locate oil filter bracket at right side of engine and install two  $\frac{1}{4}$ -20 x  $\frac{5}{8}$  screws at top of bracket, attaching breather line clip with front screw. On early vehicles, install one  $\frac{3}{8}$ -16 x  $\frac{3}{4}$  cap screw to attach oil level gage tube bracket and

oil filter bracket to cylinder block. On late vehicles, tube bracket, is attached by push rod cover screws and it not disturbed when replacing filter bracket.

- (2) Locate oil pressure sending unit bracket at filter bracket and attach brackets, using one  $\frac{3}{8}$ -16 x 1 cap screw and  $\frac{3}{8}$ -inch lockwasher. Tighten all  $\frac{3}{8}$ -inch cap screws to 20 to 30 pound-feet torque.
- (3) Clip governor lines in place, using one clip and one  $\frac{1}{4}$ -28 x  $\frac{3}{4}$  cross-recess screw and  $\frac{1}{4}$ -inch lockwasher.
- (4) Install mounting clamps (L) on filter shell and tighten clamp screws to hold clamps in place.

*Note.* Clamp screws should not be completely tightened until mounting bolts have been loosely installed.

- (5) Install inlet and outlet elbow fittings in filter. Install drain plug (K). Set oil filter assembly at mounting bracket and attach mounting clamps to bracket, using four  $\frac{3}{8}$ -24 x  $\frac{7}{8}$  cap screws, with flat washer and  $\frac{3}{8}$ -inch lockwasher on each screw. Tighten cap screws to 20 to 30 pound-feet torque.
- (6) Turn filter assembly if necessary to locate oil filter drain plug (K) toward frame side member and with inlet elbow toward front. Tighten mounting clamp screws to grip filter shell.
- (7) Connect inlet and outlet lines (G and H) to elbow fittings.
- (8) Start engine and with engine running, check line connections, drain plug, and filter cover gasket for leakage.
- (9) Replenish crankcase to FULL mark on gage.

## 110. Valve Clearance Adjustment

*a.* Start engine and run at fast idle until temperature reaches normal operating range (160° to 220° F.). Warmup time may be shortened by covering front of radiator so fan cannot draw air through radiator core; however, covering must be removed when temperature rises to normal range.

*b.* Remove cylinder head cover (par. 113b(11)).

*c.* Check all cylinder head bolts, using wrench 41-W-2964-700 with torque wrench (fig. 94). Tighten in sequence indicated in figure 102.

*Note.* Torque applied to cylinder head bolts depends upon type of bolt material as indicated by marking on bolt heads (fig. 101). If bolt heads have three radial lines (left view, fig. 101), tighten to 70 to 80 pound-feet torque. If bolts have six radial lines (right view, fig. 101), tighten to 90 to 100 pound-feet torque.

*d.* Use feeler gage to check clearance between rocker arm pad and end of valve stem or rotator cap as shown in figure 95.

*Note.* Valve clearance adjustment should be made with vehicle running at idling speed and at normal operating temperature.



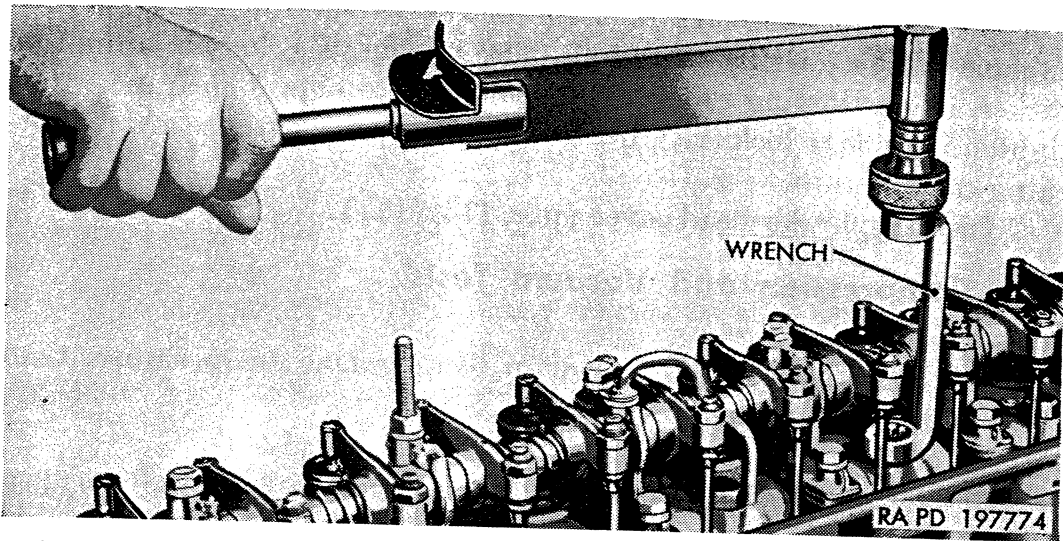

Figure 94. Use of torque wrench and wrench 41-W-2964-700 to tighten cylinder head bolts.

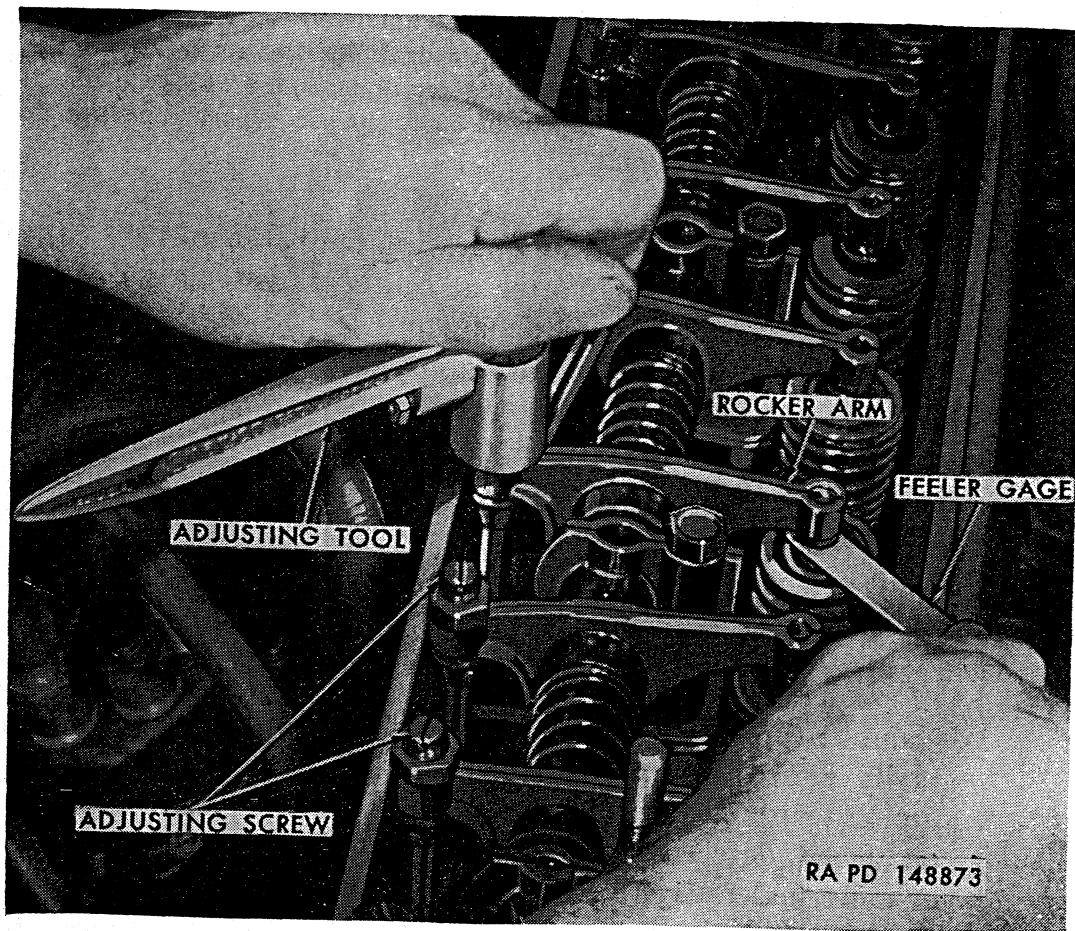

Figure 95. Valve clearance adjustment with tool 41-T-3380-60.

Correct clearance is 0.012 inch for intake valves and 0.020 inch for exhaust valves. Using tool 41-T-3380-60 (fig. 95), loosen jamnut on rocker arm adjusting screw and turn screw to obtain clearance, then tighten jamnut to lock the adjustment. Recheck clearance after tightening each jamnut.

e. Install cylinder head cover (par. 113c(12)).

## 111. Compression and Vacuum Tests

### a. Compression Test.

- (1) Start engine and warm up to operating temperature, then shut off engine.
- (2) Remove all spark plugs from engine (par. 124a).
- (3) Open throttle with hand throttle. Also be sure choke is open (choke button in).
- (4) Take compression reading at each cylinder as engine is cranked with starter. Record reading and reset compression gage at zero as each cylinder is checked.
- (5) Compare readings, which should be uniform within 30 to 40 psi.

*Note.* Engine need not be repaired immediately if readings vary 30 to 40 psi. Perform other tuneup operations, and recheck compression after vehicle has been operated for at least 100 miles. Then, if compression is not uniform within 30 to 40 psi, report condition to ordnance maintenance unit.

### b. Manifold Vacuum Test.

- (1) Warm up engine to normal operating temperature.
- (2) Remove pipe plug above tee at center of intake manifold, and connect vacuum gage to manifold.
- (3) Start engine and run at idling speed and check carburetor adjustment (par. 127b). With carburetor properly adjusted, vacuum gage should show 18 to 21 inches and indicator should be steady. Indicator fluctuating between 10 and 15 inches at regular intervals may indicate a leaking valve or defective cylinder head gasket. Abnormally low reading with steady indicator may be due to leak in intake manifold or gasket.
- (4) Accelerate and decelerate engine quickly, and observe action of vacuum gage. With quick opening of throttle, the vacuum should drop to approximately 2 inches, and should momentarily rise to approximately 24 inches as throttle is closed quickly with engine running fast. If action of gage is not as described, defective or worn piston rings, diluted engine oil, or abnormal restriction in carburetor, air cleaner, or exhaust system may be indicated.

*Note.* Above readings are for sea level operation. Vacuum gage readings will be lowered approximately 1 inch for each 1,000 feet of increase in altitude.

## 112. Intake and Exhaust Manifolds

*a. General.* Intake and exhaust manifolds are each one-piece-type. A manifold heat control valve assembly is installed in exhaust manifold. Intake and exhaust manifolds are bolted together and are removed from engine as an assembly. Carburetor assembly is installed on intake manifold, and exhaust pipe is connected to outlet at exhaust manifold as shown in figure 134.

### *b. Removal.*

- (1) Remove carburetor assembly (par. 127c).
- (2) Remove carburetor control mechanism from intake manifold (par. 128).
- (3) Remove three cap screws which attach exhaust pipe assembly to exhaust manifold. Figure 134 illustrates arrangement of parts at exhaust pipe to manifold connection.
- (4) Disconnect crankcase ventilation flexible line at valve assembly (fig. 106). Remove ventilator valve from tee in intake manifold.
- (5) On vehicles equipped with engine primer, disconnect primer line at fitting at rear of manifold.
- (6) Remove stud nuts and washers from two studs in cylinder head at each end of manifold assembly. Pull governor line clip or bracket off rear stud. Loosen balance of stud nuts sufficiently to permit turning clamps (fig. 97) to vertical position. Pull manifold assembly away from cylinder head and remove from vehicle.

*Note.* When removing manifolds, if there is not sufficient clearance due to interference with air compressor, remove drive belt from compressor pulley (par. 247b) and swing compressor away from engine to provide clearance.

- (7) Remove manifold gaskets and pilots from cylinder head.
- (8) To separate manifolds, remove stud nuts and bolts, separate the manifolds, and remove gasket. Primer lines and fittings may be removed from intake manifold if engine is so equipped. Discard gasket.

### *c. Inspection.*

- (1) Inspect manifolds for evidence of cracks, and use straight-edge to check alinement of exhaust manifold flanges (fig. 96). Flanges should be in line within one thirty-second of an inch. Clean gasket surfaces and pilot counterbores at cylinder head and manifolds. Inspect heat control valve in exhaust manifold. If valve assembly is burned or otherwise damaged, or if flanges are not in alinement, obtain new or repaired exhaust manifold assembly including heat control valve and shaft.



- (2) Inspect exhaust manifold for elongation as indicated by excessive length from centerline to centerline of end stud holes. Correct dimension is  $26\frac{7}{8}$  inches. If this dimension is incorrect, set exhaust manifold on studs in cylinder head and note clearance at studs. If necessary, file manifold to eliminate any interference between manifold and studs.

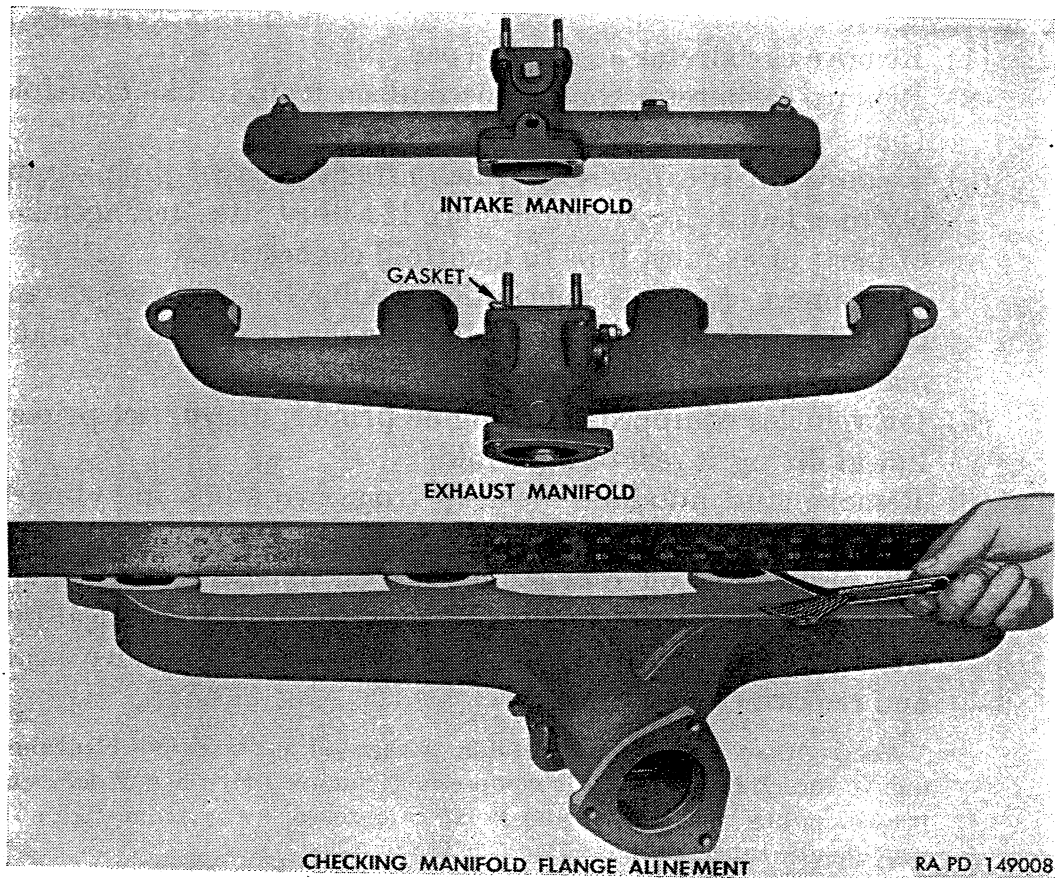

Figure 96. Inspecting manifolds.

*d. Installation.*

- (1) Assemble manifolds, using new gasket between intake and exhaust manifolds. Install bolts and stud nuts, but do not tighten until after manifold assembly is mounted on cylinder head. Accelerator lever spring bracket must be installed and retained by rear stud nut.
- (2) Insert three manifold pilots in counterbores in cylinder head and locate gaskets at cylinder head as shown in figure 97. Place four clamps on manifold studs and start nuts on threads. Set manifold assembly in place (fig. 97) at cylinder head and turn clamps to hold in place.
- (3) Install washers and stud nuts on end studs, attaching governor line clip bracket at rear stud. Tighten two stud nuts at



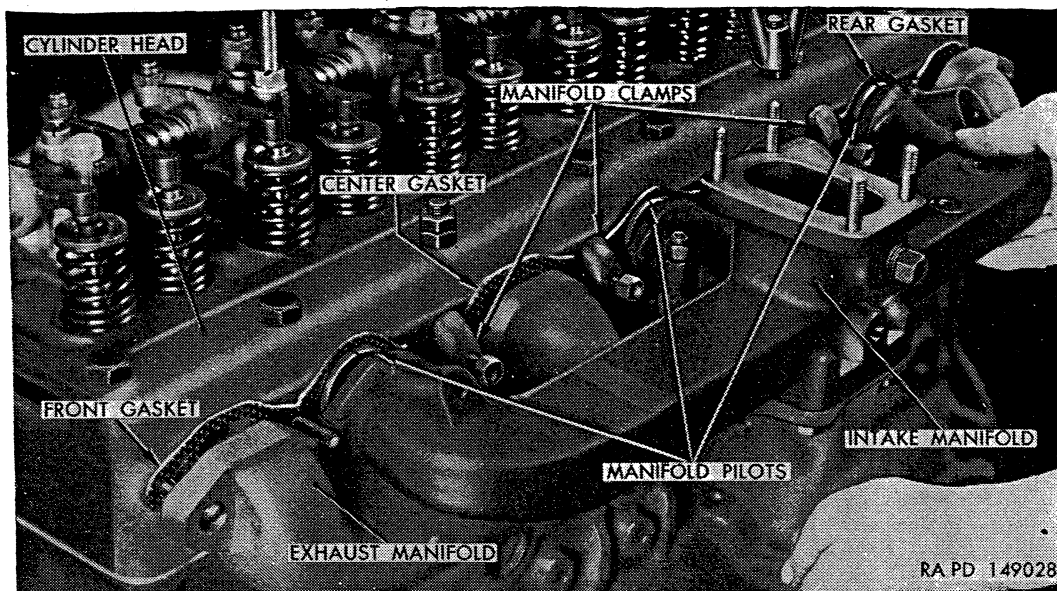

Figure 97. Installing manifolds.

each end of manifolds to 25 to 30 pound-feet torque, and tighten stud nuts at clamps to 15 to 20 pound-feet torque.

**Caution:** Do not exceed 20 pound-feet torque as clamps may collapse.

- (4) Tighten intake to exhaust manifold stud nuts and bolts firmly and set manifold heat control according to seasonal temperature (par. 135*b*).
- (5) Bolt exhaust pipe flange to manifold, using new gasket. Seal must be below gasket as shown in figure 134. Tighten nuts evenly and install locknuts.
- (6) Install tee fitting in intake manifold and install crankcase ventilator valve assembly in fitting. Connect ventilating line to valve.
- (7) If vehicle is equipped with engine fuel primer, install fittings and lines and connect primer line to fitting at rear end of manifold.
- (8) Install carburetor (par. 127*d*) and carburetor control levers (par. 128*d*).
- (9) If it has been necessary to remove air compressor belt to replace manifolds, install and adjust air compressor drive belt as instructed in paragraph 247.

### 113. Cylinder Head Assembly

*Note.* The key letters noted in parentheses are in figure 99, except where otherwise indicated.

*a. General.* Cylinder head assembly is attached to cylinder block by 15 bolts, two of which are special type studs having threaded section projecting above the bolthead. Spark plugs and valves are in-



stalled in cylinder head, and rocker arm and shaft assembly is supported by six brackets bolted to cylinder head. Rocker arms and shaft are inclosed by cylinder head cover. Refer to figure 104 for arrangement of rocker arms and method of mounting. Figure 98 shows intake and exhaust valves installed. Exhaust valves are equipped with rotator (free valve) mechanism, which permits valves to turn while valves are open.

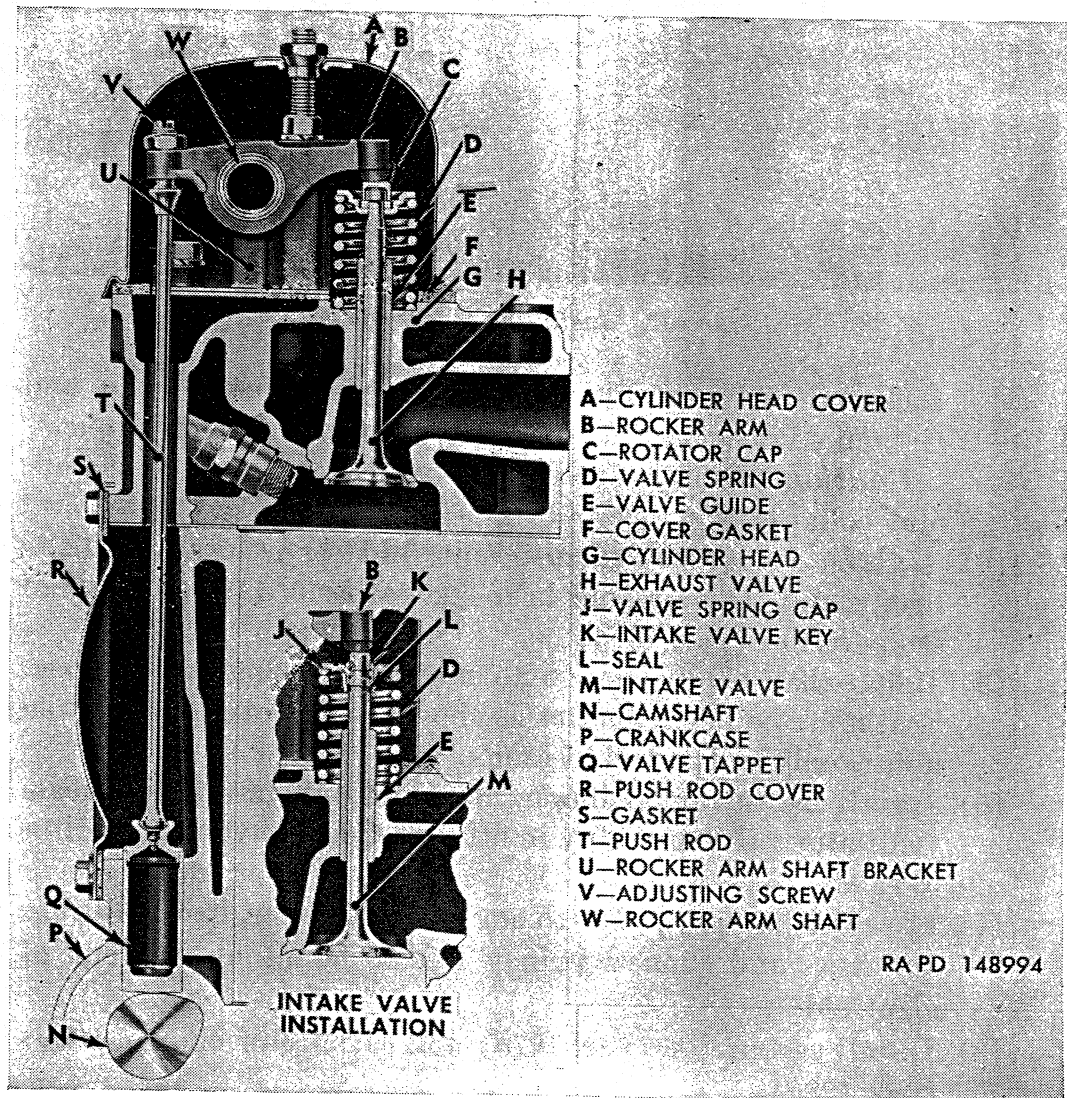
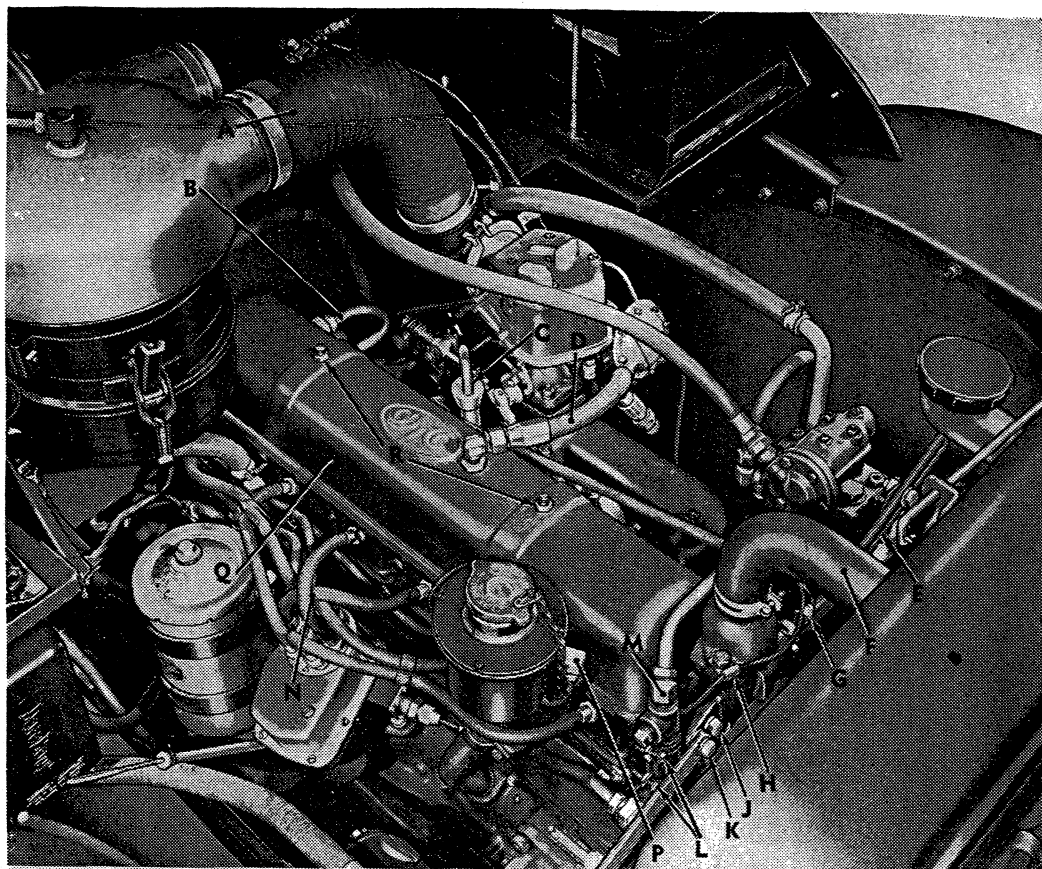

Figure 98. Valve operating mechanism.

*b. Removal.*

- (1) Open drain cock at bottom of radiator core (fig. 140) and drain cooling system to bring level below cylinder head gasket. Complete draining of system is not necessary when replacing cylinder head. Remove radiator fillercap or open level cock (fig. 138) to hasten draining.
- (2) Remove bolts holding air compressor and generator belt adjusting arms (E and K) to engine thermostat housing. Disconnect oil line from fitting at front end of cylinder head.



A—AIR INLET HOSE  
 B—WATER BYPASS LINE ASSEMBLY  
 (REAR CONNECTION)  
 C—LIFTING EYE  
 D—CRANKCASE VENTILATION LINE ASSEMBLY  
 E—AIR COMPRESSOR BELT ADJUSTING ARM  
 F—RADIATOR HOSE  
 G—WIRE CONNECTOR AT TEMPERATURE  
 GAGE SENDING UNIT  
 H—WIRE CLIP

J—THERMOSTAT LOWER HOUSING TO  
 CYLINDER HEAD BOLT  
 K—GENERATOR BELT ADJUSTING ARM  
 L—WATER PUMP BYPASS HOSE CLAMPS  
 M—WATER BYPASS LINE ASSEMBLY  
 (FRONT CONNECTION)  
 N—SPARK PLUG CABLE  
 P—CRANKCASE BREATHER VENT LINE  
 Q—CYLINDER HEAD COVER  
 R—COVER STUD NUTS

RA PD 197852

Figure 99. Disconnect points for cylinder head assembly replacement.

- (3) Remove water bypass line assembly, installed between rear connection (B) at cylinder head and front connection (M). Disconnect wire at connector (G) on temperature sending unit. Remove bolt and lockwasher securing wire clip (H) at thermostat housing. Remove two bolts (J) attaching thermostat lower housing to cylinder head. Loosen water pump bypass hose clamps (L), then remove engine thermostat housing assembly from engine.
- (4) Disconnect cables (N) from spark plugs and remove spark plugs from cylinder head (par. 124a). On early vehicles, one spark plug wire is supported in a rubber grommet at oil filler tube assembly. Remove grommet and pull spark plug cable out through hole in bracket.

- (5) Disconnect flywheel housing front breather vent line (P) at crankcase breather assembly. Remove push rod cover screws attaching oil filler tube bracket, then remove tube and bracket assembly from engine.
- (6) Remove remainder of screws attaching upper edge of valve push rod cover to cylinder head.
 

*Note.* These screws also attach wiring clips, oil filter bracket, and breather line clip.
- (7) Disconnect and remove crankcase ventilation line assembly (D) from cylinder head cover. Disconnect air inlet hose (A) from carburetor and air cleaner manifold and remove hose.
- (8) Disconnect accelerator and choke controls, and remove clevis pin from front end of throttle valve control rod (fig. 193 or K, fig. 196).
- (9) Remove nut from exhaust pipe heat shield brace stud at cylinder block, and loosen clamp connecting front and rear exhaust pipes.
- (10) Remove nuts from manifold studs; then remove clamps and washers from all studs. Force manifold assembly away from cylinder head and insert block between exhaust pipe and cylinder block to hold manifold away from cylinder head while replacing cylinder head.
- (11) Remove two stud nuts (R) which retain cylinder head cover to cylinder head. Remove cover and gasket.
- (12) Remove rocker-arm-shaft-bracket-to-cylinder-head bolts and lockwashers, and remove stud nuts from two long studs. Overflow tube and gasket (fig. 105) are held by long bolt at fourth bracket. Lift off rocker arms, shaft, and brackets as an assembly.
- (13) Remove 12 push rods from holes in cylinder head, and remove gasket (fig. 103) at oil passage in cylinder head at shaft bracket.
- (14) Remove lifting eye nut from special cylinder head bolt at left side of cylinder head. Remove 15 cylinder head bolts. Improvised lifting handles for cylinder head may be installed on long cylinder head cover studs (fig. 100) to facilitate cylinder head removal. Remove cylinder head and gasket from cylinder block.

**Caution:** Carefully move cylinder head away from push rod cover, using a blade to separate cover gasket from cylinder head without damage to gasket. Exercise care to prevent loss of exhaust valve rotator caps which are free to fall off valves after rocker arms are removed. Rotator caps must be kept with the valves on which they were originally fitted. Tape may be used to hold caps in place.



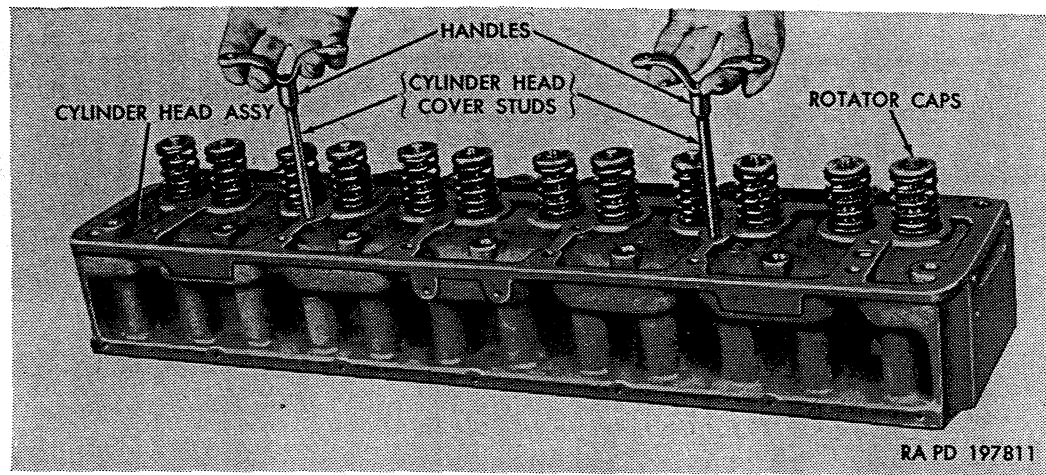

Figure 100. Improvised handles for lifting cylinder head.

*c. Installation.*

- (1) Clean top of cylinder block and surface of cylinder head, and inspect portion of push rod cover gasket visible above cylinder block. If push rod cover gasket is damaged and requires replacement, report to higher authority.
- (2) Place new cylinder head gasket on engine cylinder block. Word TOP is imprinted on upper side of gasket. Lower the cylinder head assembly into place on gasket; then thread cylinder head bolts into block. Use of bolts with six radial marks (fig. 101) is recommended whenever available.

*Note.* Two special studs are used and must be properly located as shown in figure 102.

- (3) Following the sequence indicated in figure 102, tighten cylinder head bolts evenly to recommended torque. Refer to figure 102 and tighten according to bolt head markings (par. 110c).

*Note.* Final tightening of cylinder head bolts is accomplished during tuneup procedure when engine is started, following cylinder head installation.

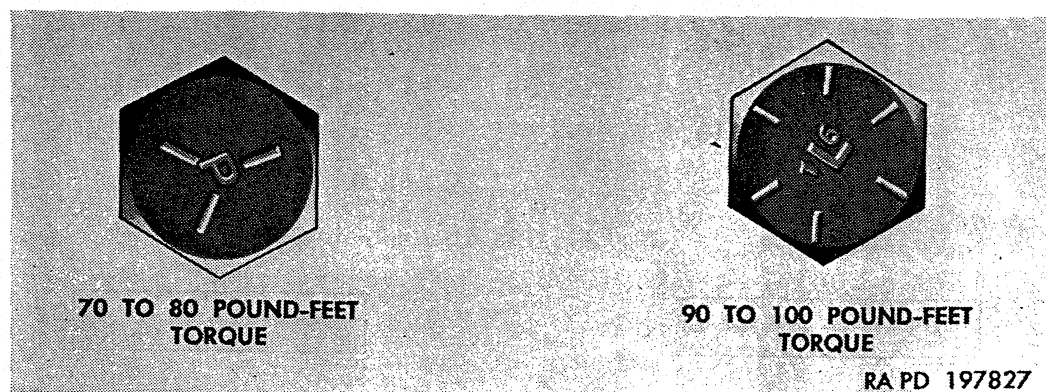

Figure 101. Cylinder head bolt markings.

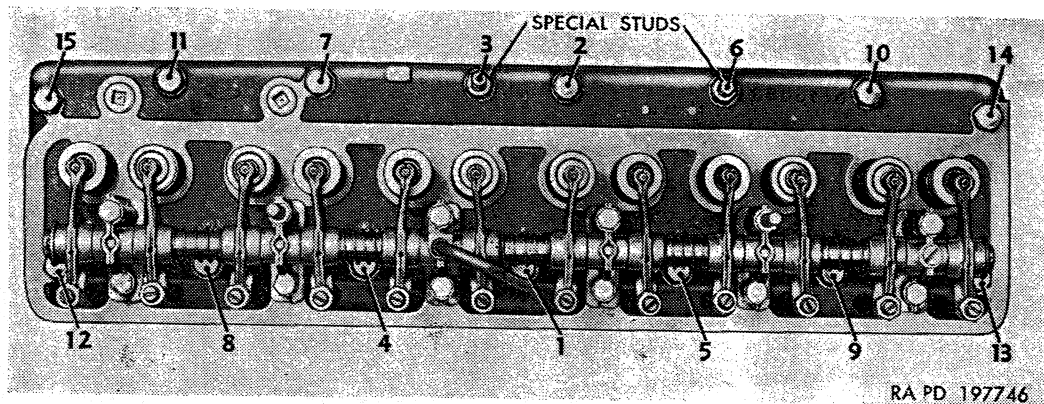

Figure 102. Cylinder head bolt tightening sequence.

- (4) Place intake manifold pilots and new manifold gaskets at cylinder head. Place four manifold clamps (fig. 97) and nuts on four studs, with clamps turned to permit installation of manifold assembly.
- (5) Lift manifold assembly into place at cylinder head, turn clamps to engage manifolds, and tighten sufficiently to hold manifold in place. Install special washers and nuts on two studs at each end of manifold assembly. Governor line clip bracket must be mounted on rear stud. Tighten all manifold stud nuts evenly and finally tighten four end stud nuts to 25 to 30 pound-feet torque; tighten nuts at manifold clamps to 15 to 20 pound-feet torque. Install and tighten clamp which connects front exhaust pipe to rear exhaust pipe.
- (6) Connect accelerator and choke controls and install nut on heat shield brace stud at cylinder block.
- (7) Insert 12 push rods (fig. 103) through push rod holes in cylinder head. Lower end of push rods must seat in sockets in valve tappets.

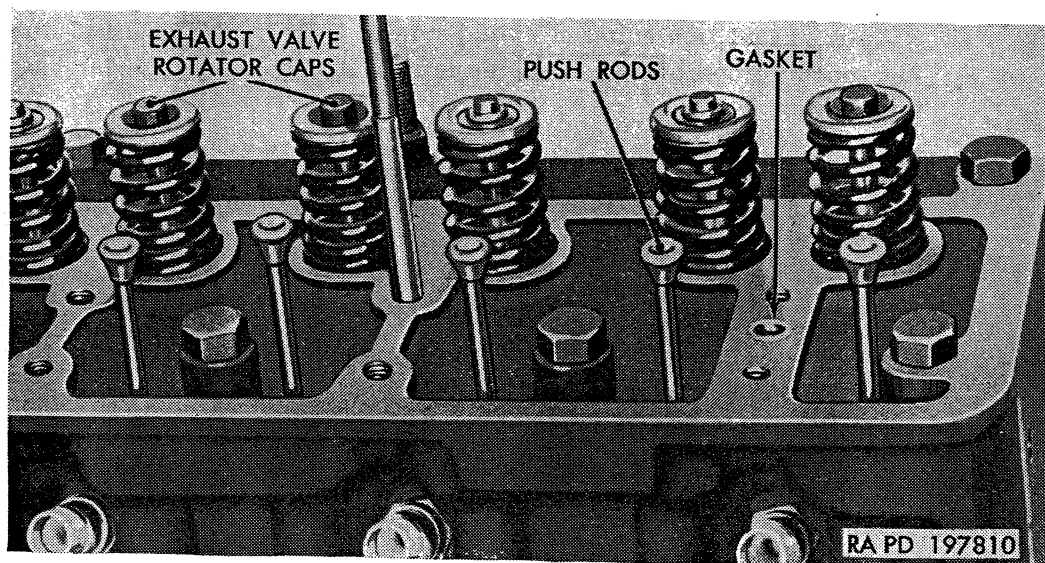

Figure 103. Push rod and bracket gasket installed.

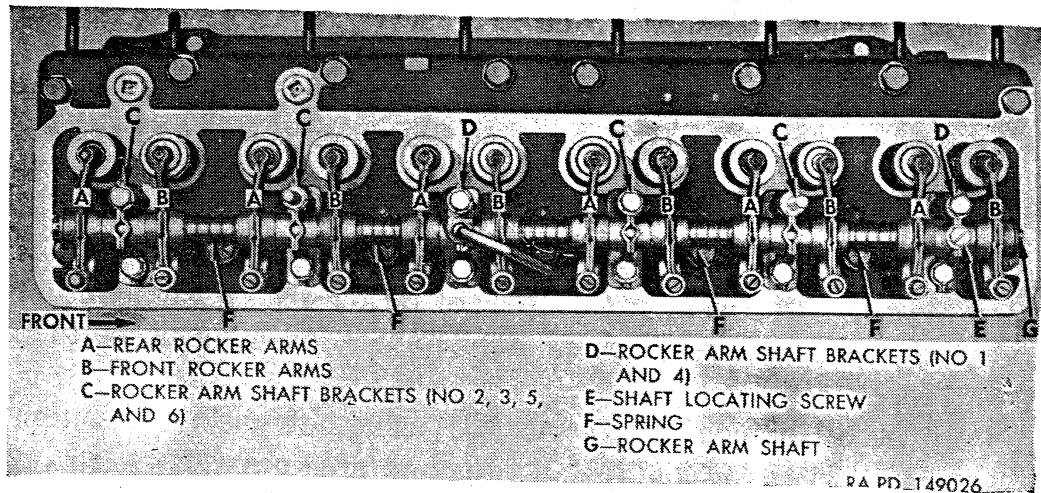

Figure 104. Valve rocker arm arrangement.

- (8) Place copper-asbestos gasket (fig. 103) in recess at rocker arm shaft front bracket position on cylinder head.
- (9) With exhaust valve rotator caps (fig. 103) in place on exhaust valves, place the rocker arms, shaft, and bracket assembly over long studs and onto cylinder head. Install one  $\frac{3}{8}$ -inch lockwasher and  $\frac{3}{8}$ -24 nut on each long stud. As stud nuts are tightened, spherical ends of rocker arm adjusting screws must seat into cups at upper end of push rods. Install four  $\frac{3}{8}$ -24 x  $3\frac{1}{4}$  bolts and  $\frac{3}{8}$ -inch lockwashers and six  $\frac{3}{8}$ -16 x  $1\frac{1}{8}$  bolts with  $\frac{3}{8}$ -inch lockwashers at rocker arm shaft brackets. Overflow tube assembly and new gasket must be assembled at No. 4 bracket as shown in figure 105. Tighten bolts and stud nuts to 20 to 30 pound-feet torque.

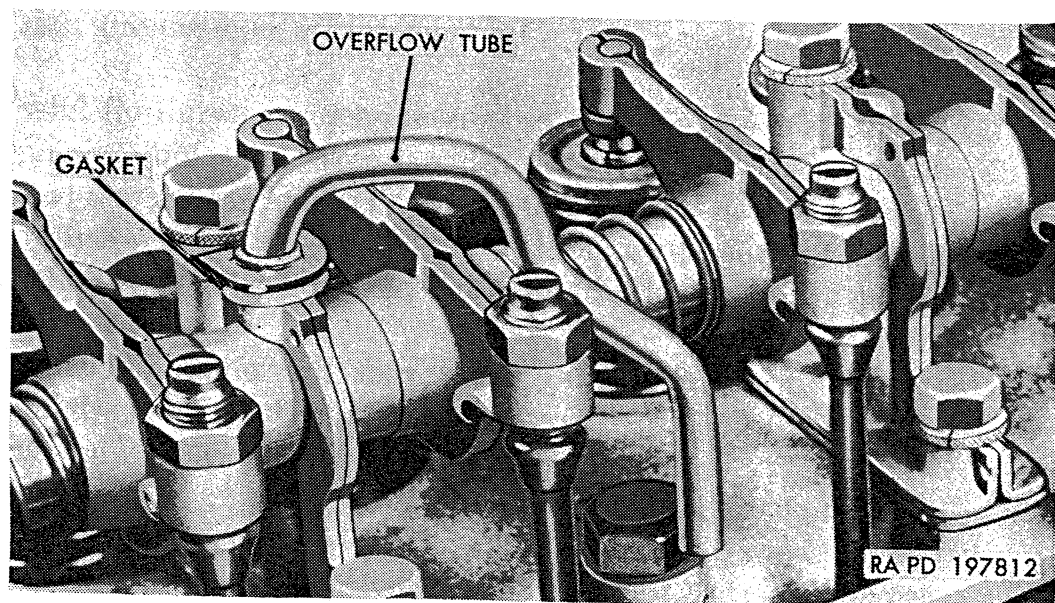

Figure 105. Rocker arm shaft overflow tube installed.

- (10) Use oiler to apply engine oil at each end of rocker arms and at oilhole at top of each rocker arm.
- (11) Using starter, turn engine to firing position on No. 1 cylinder. Make initial adjustment of valve rocker arm clearance, using feeler gage (fig. 95). Turn adjusting screw to provide 0.020-inch clearance at exhaust valve and 0.012-inch clearance at intake valve. Repeat above procedure to provide initial adjustment at each pair of rocker arms. Firing order is 1-5-3-6-2-4. Tighten nuts to lock adjustment at each rocker arm.
- (12) Install cylinder head cover (Q), using new gasket. Position cover on gasket and install two cover stud nuts (R) to retain cover. Tighten nuts only as necessary to seat cover firmly on gasket.
- (13) Install carburetor air inlet hose (A).
- (14) Using new thermostat-lower-housing-to-cylinder-head gasket, mount thermostat housing assembly on cylinder head, using two  $\frac{3}{8}$ -16 x  $1\frac{1}{2}$  bolts (J) with  $\frac{3}{8}$ -inch lockwashers. Tighten bolts to 20 to 30 pound-feet torque. Tighten water pump bypass hose clamps (L). Connect oil line at fitting in front of cylinder head.
- (15) Install water bypass line between rear connection (B) at cylinder head and front connection (M) at bypass fitting on thermostat housing assembly.
- (16) Install upper radiator hose (F) and attach wire connector at temperature gage sending unit (G) in thermostat housing. Install a  $\frac{3}{8}$ -inch lockwasher on a  $\frac{3}{8}$ -16 x 1 bolt and position wire clip (H) on bolt. Secure bolt and clip to upper-to-lower thermostat housing bolt. Clip temperature gage sending unit in wire clip.
- (17) Using three  $\frac{1}{4}$ -20 x  $\frac{5}{8}$  cross-recess screws, install oil filler tube bracket and brace at push rod cover, attaching wiring harness clip on bracket rear screw. Tighten screws to 3 to 4 pound-feet torque. Install two  $\frac{1}{4}$ -20 x  $\frac{5}{8}$  cross-recess screws which attach oil filter bracket and push rod cover to cylinder head.
- (18) Install flywheel housing front vent line clip and, using three  $\frac{1}{4}$ -20 x  $\frac{1}{2}$  cross-recess screws, attach balance of wiring harness clips and push rod cover to cylinder head. Tighten screws to 3 to 4 pound-feet torque.
- (19) With sealing ring in place at lower end of oil filler tube assembly, install tube assembly in cylinder block and retain with clamp, using two  $\frac{1}{4}$ -28 x  $\frac{7}{8}$  cap screws and  $\frac{1}{4}$ -28 safety

nuts to attach clamp to bracket. Tighten nuts to 5 to 10 pound-feet torque. Connect flywheel housing front breather vent line (P) to elbow on crankcase breather assembly.

- (20) Install spark plugs and connect spark plug cables (par. 124c).

*Note.* Cable to No. 1 spark plug on early vehicles must be threaded through hole in oil filler tube plate. Install grommet to prevent chafing.

- (21) Using spacing washer between generator belt-adjusting arm (K) and thermostat lower housing, attach adjusting arm, using one  $\frac{3}{8}$ -16 x 1 cap screw,  $\frac{7}{16}$ -inch plain washer, and  $\frac{3}{8}$ -inch lockwasher. Tighten cap screw to 20 to 30 pound-feet torque.
- (22) Attach air compressor belt-adjusting arm (E) at thermostat lower housing, using one  $\frac{3}{8}$ -16 x  $\frac{7}{8}$  cap screw and  $\frac{3}{8}$ -inch lockwasher. Tighten cap screw to 20 to 30 pound-feet torque.

*d. Final Check.*

- (1) Fill cooling system (par. 142a).
- (2) Start engine and warmup to operating temperature (par. 38).
- (3) Check cylinder head bolts (par. 110c).
- (4) Check valve clearance (par. 110).

## 114. Crankcase Ventilation System

*a. Description (fig. 106).*

- (1) Ventilation of crankcase for removal of fuel and water vapors is accomplished by circulation of air actuated by manifold vacuum. Air enters engine crankcase after passing through crankcase ventilator air cleaner, located at right side of engine. Gases from crankcase move upward through push rod compartment and into rocker arm cover where they are drawn out through ventilator hose which connects cover with ventilator valve at intake manifold. Ventilator valve acts automatically to cause steady flow of air regardless of variations in manifold vacuum.
- (2) Engine crankcase and flywheel housing are vented through ventilator (breather) at right side of engine. Ventilator incorporates an oil-bath-type air cleaner with removable element. All air entering engine crankcase must pass through air cleaner. Air enters ventilator through opening in side of outer shell.

*b. Crankcase Ventilator Valve (fig. 106).* Crankcase ventilator valve assembly is mounted on tee fitting installed in center section intake manifold below carburetor.



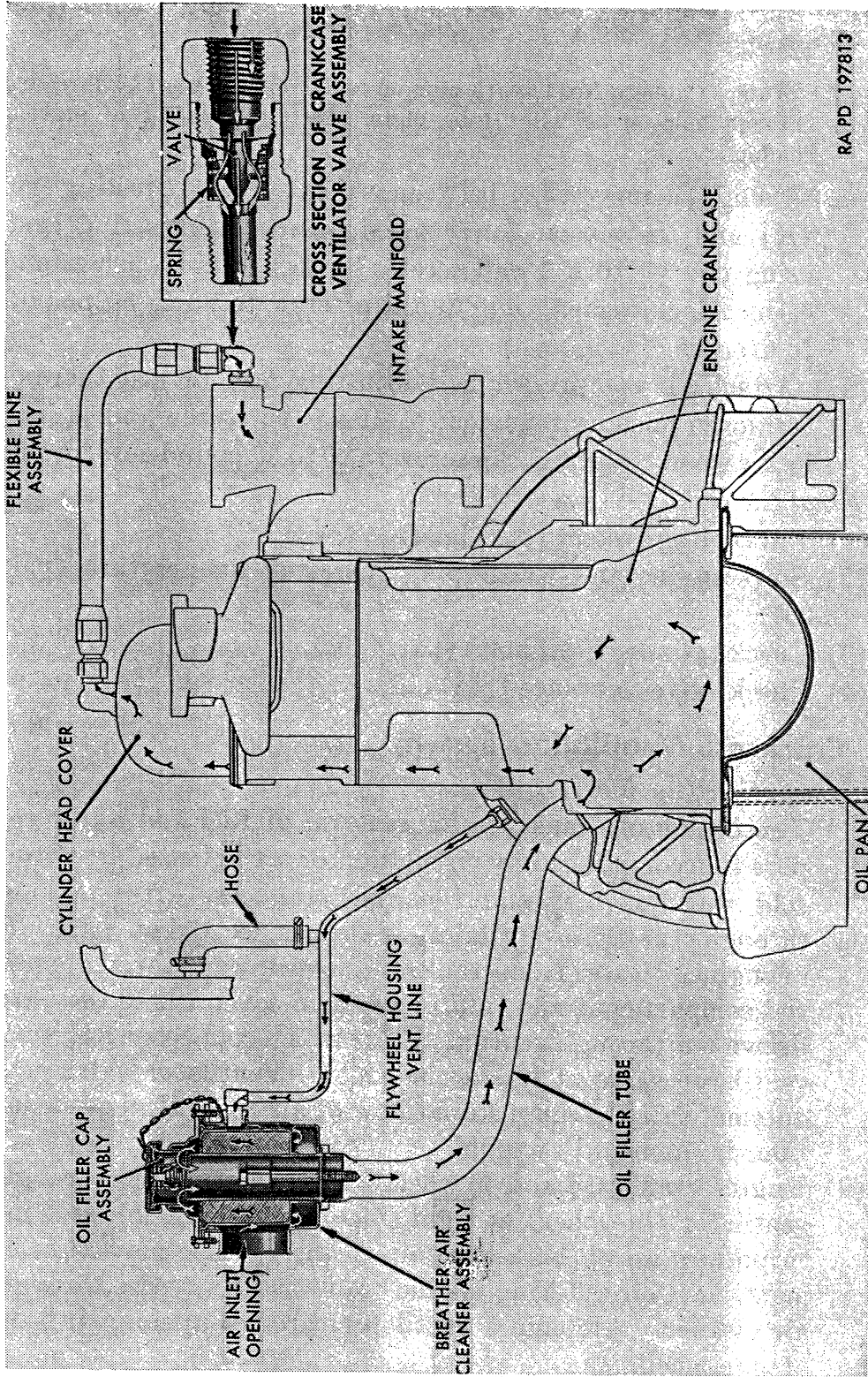

RA PD 197813

Figure 106. Crankcase ventilator system.

(1) *Removal.*

- (a) Disconnect flexible hose from elbow at ventilator valve. Using wrench on hex at manifold end of valve body, remove valve and elbow assembly from fitting at intake manifold.

*Note.* If elbow interferes with carburetor governor body, turn manifold fitting counterclockwise to provide clearance. Elbow may be screwed out of valve when necessary.

- (b) Grip valve body in vise; then turn valve retaining nut out of body. Remove valve and spring assembly. Wash valve parts in dry-cleaning solvent or volatile mineral spirits. Be sure all orifices in valve and body are clean.

- (c) Fit spring coil into groove in valve. Place valve and spring in valve body and install retaining nut. Tighten nut into body.

- (2) *Installation.* Screw valve into fitting at intake manifold. Install elbow in valve if elbow has been removed. Connect flexible hose to elbow on valve.

c. *Crankcase Breather.*

*Note.* The key letters noted in parentheses are in figure 107, except where otherwise indicated.

Crankcase breather air cleaner is oil-bath-type which can be disassembled for cleaning and replacement of parts.

(1) *Element removal and cleaning.*

- (a) Remove oil filler cap (F); then loosen four screws (B) which attach element assembly (D) to shell (A). Lift element assembly and gasket from shell. Discard gasket (C).

- (b) Rinse element in dry-cleaning solvent or volatile mineral spirits; wipe clean and allow to dry.

- (c) Disconnect vent line (H) from shell. Using screwdriver or socket wrench, remove bolt which mounts breather assembly on oil filler tube (fig. 106). Remove shell and discard gasket. Pour out oil and clean reservoir, using clean cloth and dry-cleaning solvent.

- (d) Using new gasket, mount shell on oil filler tube and connect vent line (H). Tighten mounting bolt.

(2) *Element installation.*

- (a) Fill breather shell with engine oil to OIL LEVEL mark. Use same type and grade of oil as is being used in engine crankcase.

- (b) Place new element gasket (C) at element flange, then set element assembly (D) into shell (A) and retain with four screws (B). Install oil filler cap (F).

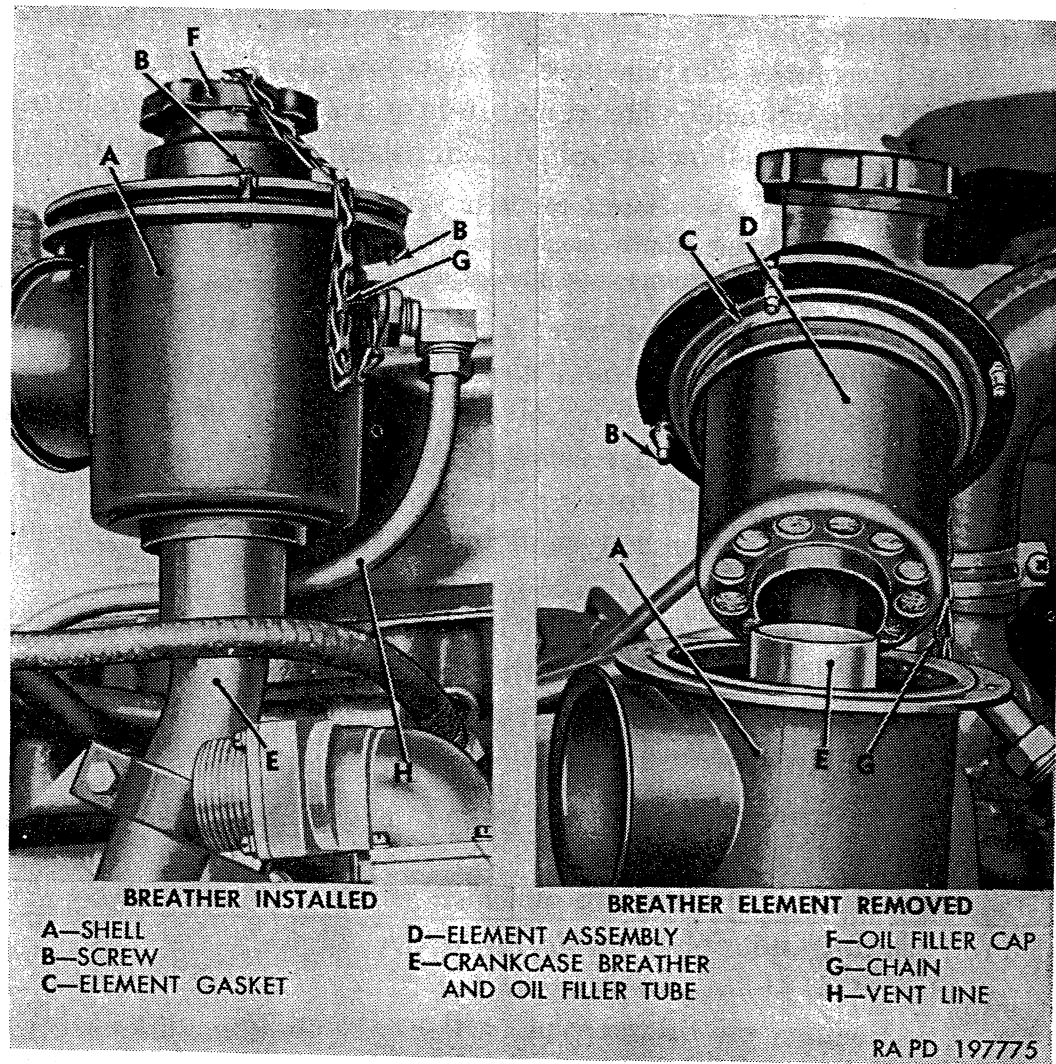

Figure 107. Crankcase breather element.

## 115. Engine Mountings

(fig. 108)

### a. Rear Support Cushion Removal.

- (1) Remove bolt (X) and lockwasher (Y) attaching transmission to each rear support cushion assembly (AA).
- (2) Place jack under rear end of power plant and raise sufficiently to provide clearance for removing cushion assemblies.
- (3) Remove the two bolts and safety nuts attaching each cushion assembly (AA) to rear support (W). Remove cushion assemblies.

### b. Rear Support Cushion Installation.

- (1) Locate rear support cushion assemblies at rear support (W) and install two  $\frac{7}{16}$ -20 x 1 bolts and safety nuts to attach each cushion assembly (AA) to support (W). Tighten nuts to 33 to 43 pound-feet torque.

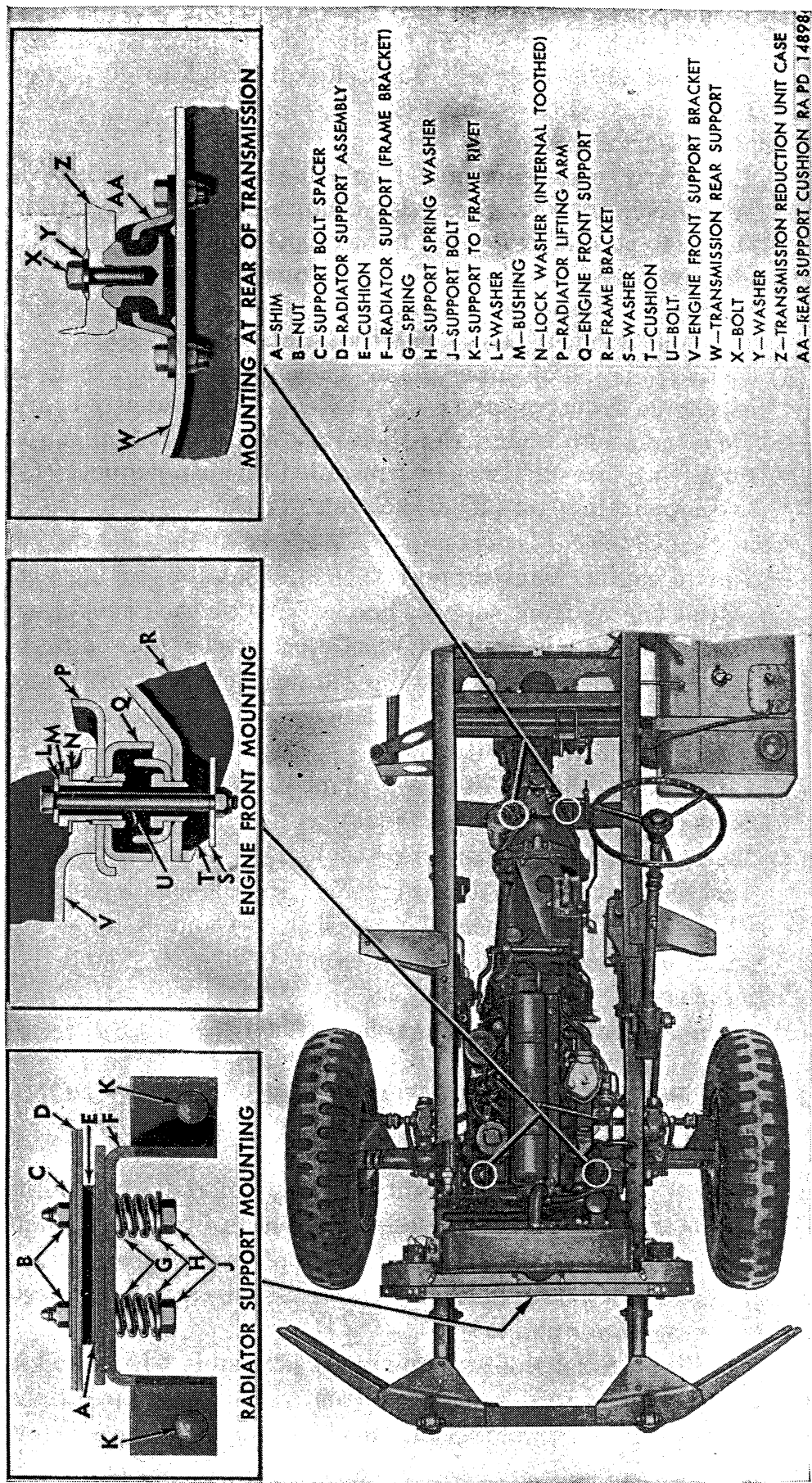

Figure 108. Power plant mountings.



- (2) Remove jack and install one  $\frac{1}{2}$ -20 x  $1\frac{3}{8}$  bolt (X) with  $\frac{1}{2}$ -inch heavy lockwasher (Y) to attach power plant to rear support cushion assemblies. Tighten bolts to 25 to 30 pound-feet torque.

*c. Front Support Removal.*

- (1) Loosen air compressor mounting bolt and belt adjusting arm bolt at compressor. Swing air compressor assembly toward engine to permit removal of left support bolt.
- (2) Remove nuts from bolts (U), and remove washer (S) and cushion (T) from lower end of each bolt (U). Remove bolts (U) and washers (L) at right and left supports (Q).
- (3) Raise front end of power plant sufficiently to permit removal of engine front supports (Q). Remove threaded bushing (M) and lockwasher (N); then remove support and radiator lifting arm (P) which is installed between support (Q) and support bracket (V) at each side of engine.

*d. Front Support Installation.*

- (1) Locate engine front support (Q) and radiator lifting arm (P) at engine front support bracket (V) on each side of engine. Place a 1-inch internal-teeth lockwasher (N) on bushing (M); then insert bushing through brackets (V) and thread bushing into support. Use box end or socket wrench to tighten bushing firmly.
- (2) Lower the front end of power plant so weight rests on supports (Q) and frame brackets (R).
- (3) Insert one special  $\frac{3}{8}$ -24 to  $4\frac{1}{2}$  bolt (U) with  $1\frac{5}{32}$ -inch washer through each bushing (M); then assemble cushion (T) and large  $1\frac{3}{32}$ -inch plain washer (S) and  $\frac{3}{8}$ -24 safety nut at lower end of bolt. Tighten nut to 20 to 27 pound-feet torque.
- (4) Adjust air compressor drive belt (par. 247a).

## **Section VI. POWER PLANT REMOVAL AND INSTALLATION**

### **116. General**

*a. Description.* Power plant assembly consists of radiator, engine and accessories, and transmission assembly. The entire power plant must be removed from the chassis in order to replace engine assembly; but engine accessories, radiator, and transmission can be replaced without removing power plant.

*b. Accessibility.* All disconnect points are accessible when hood is raised and when floor pan is removed from cab. Some operations are done from engine compartment, some in cab, and some below vehicle.



*c. Equipment.* In addition to mechanic's common handtools, one special tool is required to accomplish power plant removal. Lifting sling B7950988 is necessary to lift power plant out of vehicle. Lifting eye on cylinder head special stud and a bracket at flywheel housing are located to provide proper balance when sling is attached for lifting power plant (fig. 110).

*d. Coordination With Ordnance Maintenance Unit.* Refer to paragraph 2 for information on coordination with an ordnance maintenance unit.

## 117. Power Plant Removal

**Caution:** To avoid personal injury and possible damage to equipment, disconnect battery cables and open drain cock at each air storage tank to exhaust air from system before performing other operations for power plant removal.

*Note.* The key letters noted in parentheses are in figure 109, except where otherwise indicated. These key letters indicate disconnect points.

*a. Preliminary Operations.* Floor pan must be removed from cab floor, and transmission controls must be removed from inside cab to allow access to disconnect points and permit removal of power plant. It is not necessary to drain cooling system, engine crankcase, or to drain transmission fluid when removing power plant assembly. On late vehicles without winch, the front bumper center splash shield may be removed to provide more clearance when lifting out power plant.

*b. Operations at Front of Vehicle.* Remove two fender-to-side-baffle bolts (F) which attach brush guard and radiator side baffles to each front fender. Loosen but do not remove two baffle-to-fender skirt bolts (H).

*c. Operations in Engine Compartment.*

- (1) Attach radiator tie rod (D, fig. 111) at special stud at left side of cylinder head. Tie rod is clipped to radiator support for use only when removing power plant assembly.
- (2) Disconnect headlight wiring harness connector (M) at right side of radiator, and generator wiring harness connector (N) at generator, using spanner wrench.
- (3) Disconnect cable No. 7 at starter and cable No. 82 at starter switch (fig. 145). Remove bolt attaching engine ground strap (P) to frame right side member. Disconnect generator bracket ground strap from frame.
- (4) Loosen hose clamp and remove crankcase breather vent hose from nipple (W) on vent tube.
- (5) Loosen hose clamp holding air cleaner hose at air cleaner manifold (A), also loosen clamp at carburetor inlet elbow and remove hose assembly.

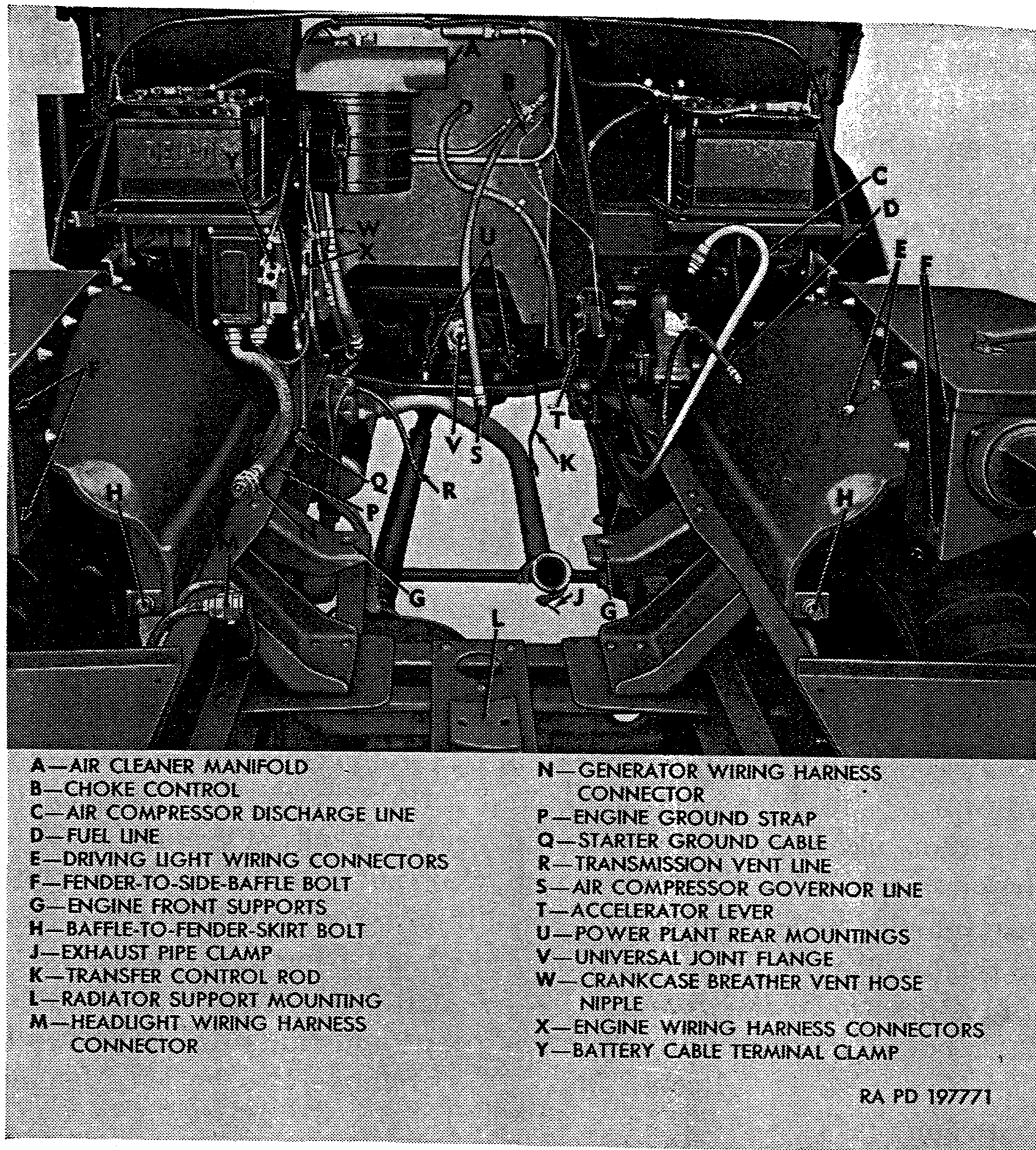

Figure 109. Disconnect points for power plant removal.

- (6) At air compressor, disconnect discharge line (C) and detach discharge line clip at base of air compressor. Also, disconnect air compressor governor line (S) at governor on compressor.
  - (7) Disconnect two blackout driving light wiring connectors (E) at left side of radiator.
  - (8) If engine is equipped with primer lines, disconnect line from fitting at rear of intake manifold.
  - (9) Disconnect choke control (B) and disconnect rod from accelerator lever (T). Close fuel line shutoff cock (D, fig. 122). Disconnect fuel line (D) at carburetor and unhook spring supporting fuel line.
- d. Operations in Cab.
- (1) Remove transmission control tower (par. 203).
  - (2) Disconnect vent line (R) from fitting at transmission.

- (3) Remove two bolts holding power plant on rear mountings (U).

*e. Operations Under Vehicle.*

- (1) Remove cotter pin and clevis pin attaching transfer reverse rod to transmission shift lever. Remove rod from lever. Refer to figure 197.
- (2) Remove cotter pin and clevis pin attaching reduction unit control rod to reduction unit control lever. Remove rod from vehicle. Refer to figure 197.
- (3) On gasoline tank trucks M217 and water tank trucks M222, disconnect Mechanovac governor flexible drive shaft at governor speed unit attached to flywheel housing.
- (4) Remove four bolts connecting transmission-to-transfer universal joint flanges (V).
- (5) Remove clamp (J) which connects front and rear exhaust pipes.
- (6) Remove nuts from bolts at engine front supports (G). Remove large plain washer and cushion from lower end of each mounting bolt.
- (7) Remove two bolts from radiator support mounting (fig. 108). A spring and a washer are installed on each bolt.

*f. Removal From Vehicle (fig. 110).*

- (1) Attach hoist to cross bar of engine lifting sling B7950988 (fig. 110); then engage short hook of sling with lifting eye on cylinder head stud and engage long hook at lifting bracket on flywheel housing.
- (2) Lift power plant off mountings, being careful to note if all lines, wiring, and attaching bolts have been removed. Move power plant forward in gradual stages, raising as necessary to clear front cross member. If vehicle has a winch, raise the power plant to provide necessary clearance. Move power plant forward, and support in manner which will permit access to drain plugs in transmission, torus cover, and engine oil pan.

**Caution:** Do not permit weight of power plant to rest on oil pan or on radiator support.

## 118. Engine Assembly Removal

*a. General.* The complete power plant assembly (fig. 111) must be removed from vehicle as an assembly (pars. 116 and 117), after which engine assembly may be removed as directed in this paragraph.

*Note.* Two-piece flywheel housing is part of engine assembly, and both halves must remain with engine on which they were originally installed. These halves include engine serial number as illustrated in figure 208. The key letters noted in parentheses are in figure 108, except where otherwise indicated.

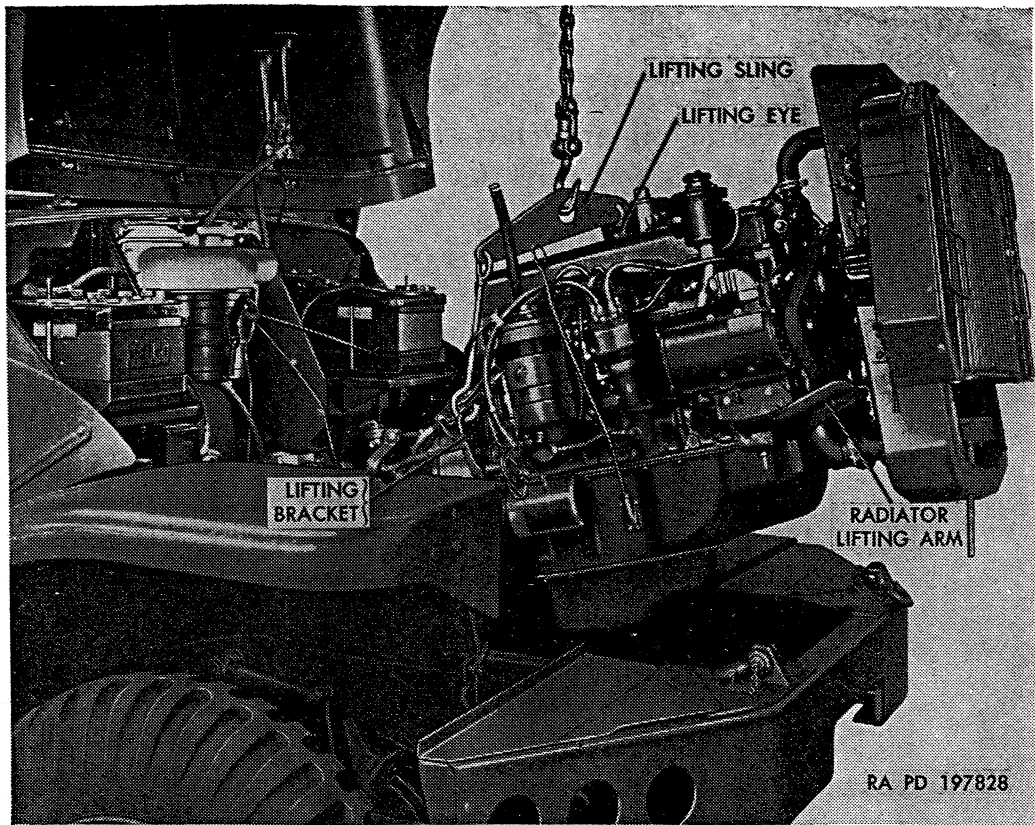

Figure 110. Removing power plant using engine lifting sling—B7950988.

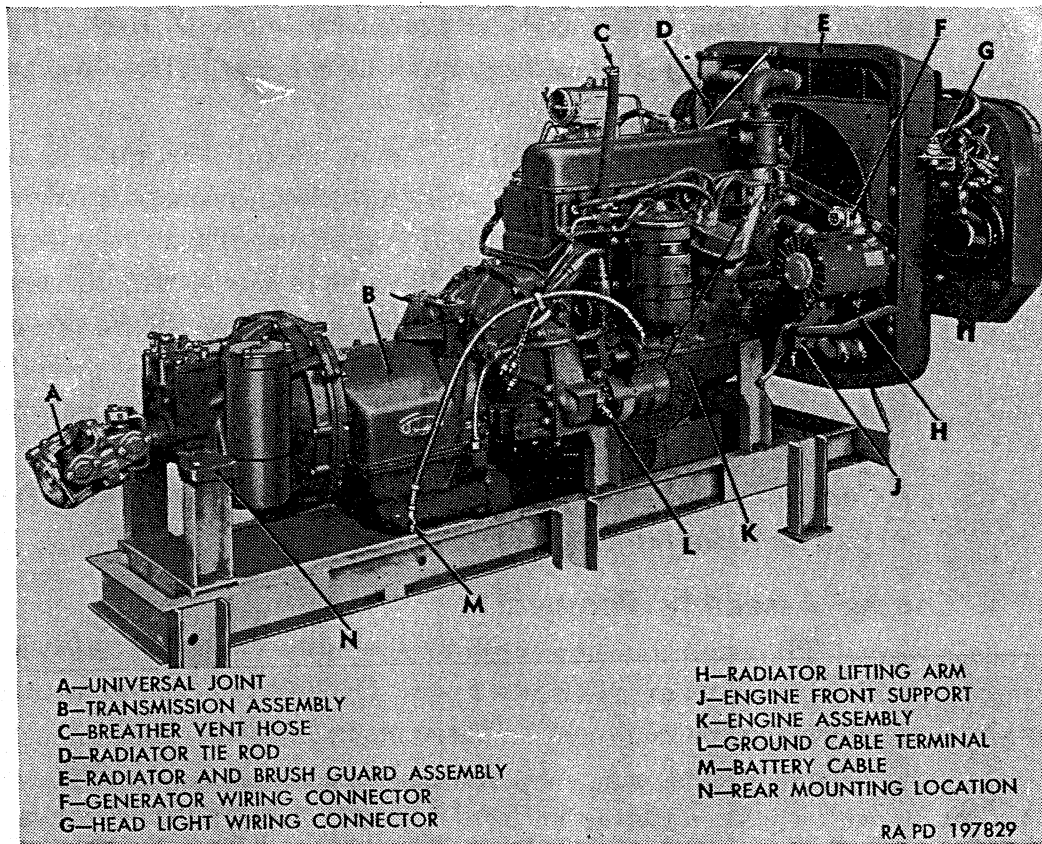

Figure 111. Power plant assembly removed from vehicle.

*b. Cooling System and Transmission Draining.*

- (1) Using suitable receptacles, drain radiator and cylinder block, and remove drain plug marked WATER from transmission oil pan.
- (2) Remove flywheel housing cover and gasket. Turn flywheel so drain plug in torus cover is at the bottom and remove plug to drain transmission oil from torus cover. Refer to figure 186. Remove drain plug marked OIL from transmission oil pan and drain all oil from transmission. Remove drain plug from rear of transmission and drain oil from reduction unit housing.

*c. Radiator, Support, and Brush Guard Removal.*

- (1) Loosen radiator hose clamps and twist hoses to loosen from radiator and engine.
- (2) Remove nut holding radiator tie rod to cylinder head stud. Clip tie rod (D, fig. 111) in place at radiator support.
- (3) Lift radiator and brush guard assembly off radiator lifting arms and remove from engine.

*d. Engine Front Support Removal* (fig. 108). Remove bushing (M) and lockwasher at each front mounting bracket, and remove engine front supports (Q) and radiator lifting arms (P). Swing air compressor toward engine to provide sufficient clearance for removing bushing (M) and bolt (U).

*e. Front Exhaust Pipe and Heat Shield Removal* (fig. 134).

- (1) Remove jamnuts (B) from flange cap screws (F); then remove nuts (C) and screws (F).
- (2) Remove brace stud nut (L) and lockwasher from heat shield brace stud in cylinder block and loosen clamp bolt in heat shield clamp (J).
- (3) Remove front exhaust pipe (G), seal (E), and gasket (D) from manifold.

*f. Transmission Removal From Engine.*

- (1) Remove cotter pin and clevis pin attaching throttle valve control rod to throttle valve lever. Remove rod from lever. Refer to figure 193 or 196.
- (2) Remove transmission from engine (par. 204*d*).
- (3) Remove torus members and flywheel housing rear half from transmission (par. 204*d* (4)).
- (4) Install flywheel housing rear half on flywheel housing front half which remained on engine. A matched pair of flywheel housing halves are furnished with replacement engine.

## 119. Engine Assembly Installation

*a. General.* A complete power plant composed of engine assembly, mountings, transmission, and radiator assembly must be installed as a unit (fig. 111).



*b. Transmission Installation to Engine.*

- (1) Remove flywheel housing rear half from engine; then install housing rear half and torus members on transmission (par. 205c).
- (2) Install transmission on engine (par. 205d).
- (3) Attach throttle valve control rod to throttle valve lever, using clevis pin and cotter pin. Refer to figure 193 or 196.

*c. Engine Front Support Installation (fig. 108).*

- (1) Locate engine left front support (Q) and radiator lifting arm (P) at engine front support bracket; then thread bushing (M) with new 1-inch internal-teeth lockwasher through support bracket and into support assembly.

*Note.* Air compressor must be tilted toward engine to provide sufficient clearance for installing bushing (M) and bolt (U).

- (2) Attach engine support (Q) and radiator lifting arm (P) at right support bracket, using bushing (M) and 1-inch internal-teeth lockwasher. Tighten bushings into supports.

*d. Radiator, Support, and Brush Guard Installation.*

- (1) With upper and lower radiator hose installed on engine, lift radiator support and brush guard assembly into position at front of engine. Engage lifting brackets on radiator support with lifting arms on engine; radiator hose must fit onto radiator inlet and outlet.
- (2) Position radiator tie rod (D, fig. 111) at cylinder head special stud and install stud nut.
- (3) Position radiator hose clamps, but do not tighten clamps until power plant is installed in vehicle.

*e. Front Exhaust Pipe and Heat Shield Installation (fig. 134).*

- (1) Locate front exhaust pipe (G), seal (E), and gasket (D) at exhaust manifold (A), and install three  $\frac{3}{8}$ -16 x 2 bolts and  $\frac{3}{8}$ -16 nuts to attach exhaust pipe assembly to manifold.
- (2) Install heat shield assembly and clamp (J) on exhaust pipe with heat shield brace (K) toward stud at cylinder block. Install flat washer on stud; then position brace on stud. Install  $\frac{5}{16}$  lockwasher and  $\frac{5}{16}$ -24 safety nut to attach brace to stud. Fit clamp over lug on shield; then tighten clamp bolt and stud nut. Tighten nuts (C) on exhaust-pipe-flange-to-manifold bolts, and install stamped jamnut (B) on each bolt.

## **120. Power Plant Installation**

*Note.* The key letters noted in parentheses are in figure 109, except where otherwise indicated.

*a. General.* Make careful inspection of all engine accessories such as starter, generator, distributor, air compressor, and water pump to

be certain that all attaching bolts and line connections are properly tightened. Seals must be in place on governor lines as shown in figure 125. Be sure external oil and water line fittings and connectors are tightened.

*b. Positioning Power Plant into Vehicle.*

- (1) Attach engine lifting sling B7950988 to lifting eye and lifting bracket at flywheel housing, then raise power plant high enough to clear frame and move into position in engine compartment as shown in figure 110.
- (2) Carefully lower power plant into position as it is moved rearward, taking care to avoid damaging lines, wiring, and cables. Fit front exhaust pipe into rear pipe, using new seal (par. 138c). Do not rest power plant solidly on mountings until shims and cushion (A and E, fig. 108) are in position on bracket. Boltholes in bracket, cushion, and shims must be alined with holes in radiator support. Insert special  $\frac{3}{8}$ -24 x  $4\frac{1}{2}$  mounting bolt and large  $1\frac{5}{32}$ -inch plain washer through engine right front mounting. Detach radiator tie rod (H, fig. 112) from cylinder head special stud and clip tie rod in place at radiator support.

*c. Operations Under Vehicle.*

- (1) Aline holes in universal joint flanges (V) at rear of transmission and install four  $\frac{1}{2}$ -20 x  $1\frac{3}{8}$  bolts with  $\frac{1}{2}$ -20 safety nuts. Tighten nuts to 48 to 64 pound-feet torque.
- (2) Assemble cushions, flat washers, and nuts on engine front mounting bolts (U, fig. 108) and tighten nuts to 20 to 27 pound-feet torque.
- (3) Assemble washers and radiator support springs on radiator support bolts (J, fig. 108), insert bolts upward through mounting, and install spacer and nuts on bolts.
- (4) Install exhaust pipe clamp (J) connecting front and rear exhaust pipes.
- (5) Connect transfer reverse rod to transmission shift lever, using clevis pin and cotter pin. Refer to figure 197.
- (6) Connect reduction unit control rod to reduction unit control lever, using clevis pin and cotter pin. Refer to figure 197.
- (7) On gasoline tank trucks M217 and water tank trucks M222, connect Mechanovac governor flexible drive shaft at governor speed unit attached to flywheel housing.

*d. Operations in Cab.*

- (1) Install two  $\frac{1}{2}$ -13 x  $1\frac{1}{2}$  bolts and  $\frac{1}{2}$ -inch heavy lockwashers to attach rear end of transmission to rear supports (W, fig. 108).
- (2) Install transmission control tower on transmission (par. 203).

(3) Connect transmission vent line (J, fig. 200) to transmission oil filler tube.

(4) Install front floor pan and seal on cab floor.

*e. Operations at Front of Vehicle.* Install fender-to-side-baffle bolts (F) which attach brush guard and radiator support to fenders, and tighten bolts (H) which attach baffles-to-fender-skirts.

*f. Operations in Engine Compartment.*

(1) Tighten radiator hose clamps.

(2) Install air inlet hose which connects carburetor air intake with air cleaner manifold (A). Also connect air compressor governor line (S) at air compressor.

(3) Connect choke control (B) and connect accelerator rod at accelerator lever (T).

(4) Connect fuel line (D) at carburetor and hook fuel line spring at carburetor fitting. If vehicle is equipped with primer lines, connect line to fitting at rear of intake manifold.

(5) Connect air compressor discharge line (C), and attach line at clip on base of air compressor.

(6) Connect driving light wiring connectors (E), generator wiring harness connector (N), and engine ground strap (P) at frame side member, and headlight wiring harness connector (M) at right side of radiator assembly. Tighten connector nuts at headlight wiring connector and generator wiring harness connector, using spanner wrench.

(7) Connect starter cable No. 7 at terminal on starter and cable No. 82 at starter switch (fig. 145). Connect engine wiring harness at connectors (X).

(8) Install crankcase breather vent hose at nipple (W) on vent line at dash. Tighten hose clamp screw to secure hose on nipple.

(9) Connect battery cable terminal clamp (Y) to terminal on battery.

*Note.* When attaching clamp at battery terminal, look for electric spark which indicates closed or grounded circuits or electrical units. Be sure all switches are turned off.

(10) Check operation of all lights and other electrical equipment.

**Caution:** Do not attempt to start engine until checks and inspections listed in *g* below have been made.

*g. Final Checks and Inspections.* Proceed with following checks and inspections (fig. 112) before attempting to start engine.

(1) Check fuel supply in tank. When certain there is fuel in tank, turn on ignition switch which will cause fuel pump to operate. With fuel pump operating, check fuel line and car-

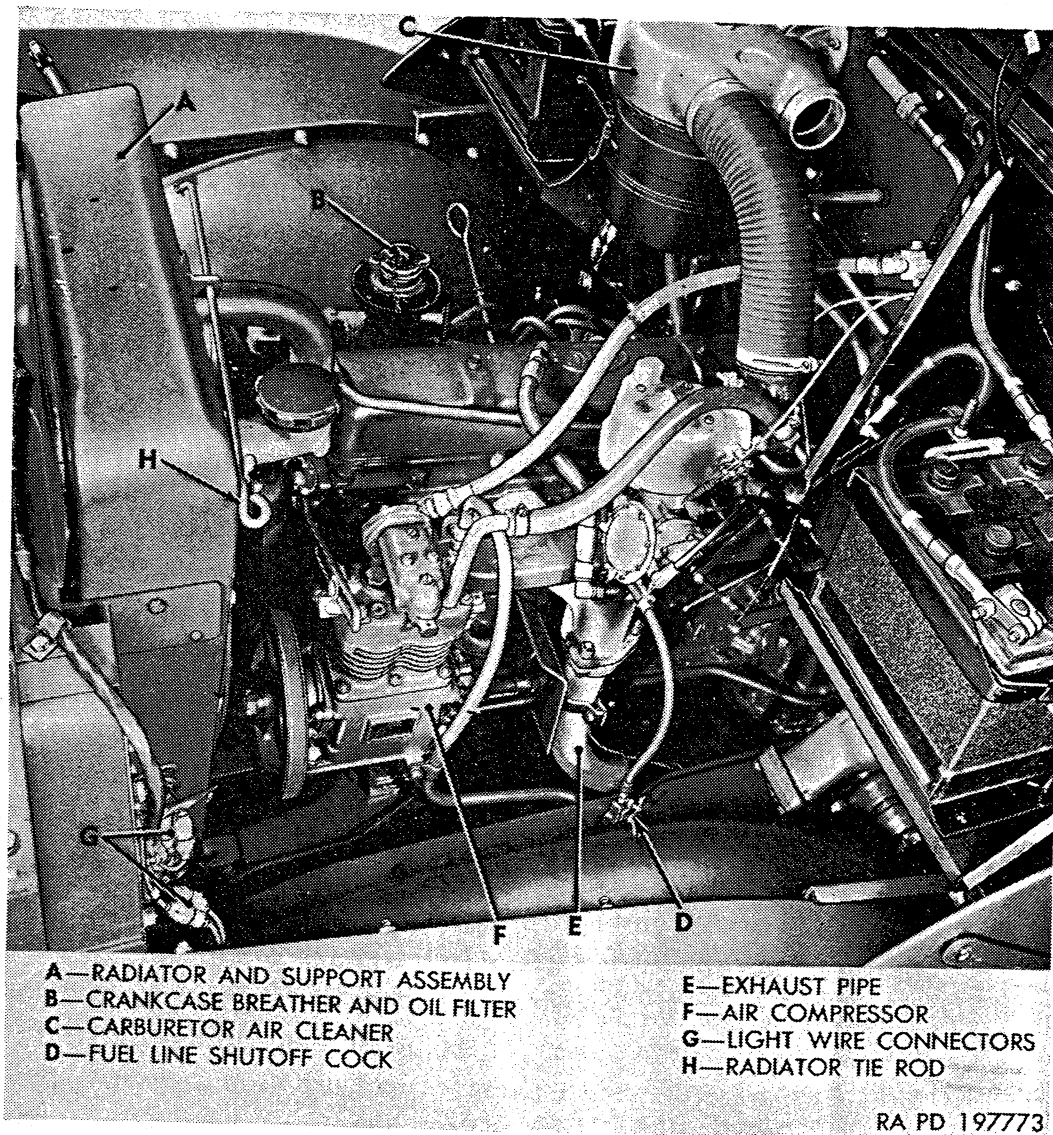

Figure 112. Power plant installed—left side shown.

buretor for leaks. Fuel line shutoff cock (D, fig. 112) must be open to permit fuel to reach carburetor.

- (2) Check oil level at crankcase breather air cleaner, carburetor air cleaner, engine crankcase, and transmission. Refer to lubrication chart (par. 69) for lubrication information for respective units.
  - (3) Close drain cocks and fill cooling system, following procedure given in paragraph 142a. Check all cooling system hoses, lines, and fittings for leaks.
  - (4) Close drain cocks in air supply tanks.
- h. Check Engine and Transmission Operation.* Refer to paragraph 37a and start engine.
- (1) Check action of gages.

*Note.* If oil pressure gage does not indicate pressure when engine is started, stop engine immediately and locate trouble before starting engine again.

- (2) Adjust transmission manual and throttle linkage (par. 202*b* and *c*).
  - (3) Perform transmission operation tests (par. 197) before putting vehicle into operation.
- i. Record of Replacement.* Record the replacement on DA Form 478.

## Section VII. IGNITION SYSTEM

### 121. Description and Data.

*a. Description.*

- (1) *General.* The ignition system consists of the source of power (battery or generator), ignition switch, distributor, coil, spark plugs, and primary and secondary circuit wiring. The ignition system produces and delivers high voltage surges to the spark plugs at timed intervals. Each high voltage surge produces a spark at the spark plug to which it is delivered, igniting the mixture of air and fuel in the cylinder. Ignition system is completely shielded for radio interference suppression (par. 189), and sealed for submerged operation.
- (2) *Distributor and ignition coil assembly.* The distributor and ignition coil assembly is a unit designed to convert low voltage (primary circuit) into high voltage (secondary circuit); to distribute the high voltage to the spark plugs; and to vary the timing of the spark automatically to provide efficient operation of the engine. Distributor mechanism and ignition coil, together with three capacitors (condensers), primary circuit resistor, and governor spinner valve are assembled in the distributor housing. Distributor is mounted on right side of engine. Distributor shaft is driven from engine camshaft by spiral cut gears. Lower end of distributor shaft is tongued and engages a slot in upper end of oil pump shaft to drive oil pump. Operation of governor centrifugal-type valve, which is driven by distributor shaft, is described in paragraph 129.
- (3) *Spark plugs.* Each spark plug consists of a shell, insulator, and center electrode. The center electrode is completely insulated from the shell by the insulator. A grounded electrode is integral with the shell. When high voltage surge is delivered to the spark plug center electrode, it jumps the gap to the grounded electrode, producing a spark which ignites the air-fuel mixture in the cylinder. A 10,000-ohm resistor is built into each spark plug for radio interference suppression.



(4) *Ignition system circuits* (fig. 113). There are two distinct electrical circuits in the ignition system, the primary and the secondary. The primary, or low voltage circuit, includes the source of electrical energy (battery or generator), ignition switch, distributor contact points and circuit breaker mechanism, primary winding of the ignition coil, and the ignition coil capacitor (condenser). The secondary, or high voltage circuit, includes the secondary winding of the ignition coil, distributor rotor and cap, spark plugs, and spark plug cables.

*b. Data.*

Distributor and ignition coil assembly :

Make.....	Delco-Remy
Model number.....	1111565
Ordinance number.....	7350410
Rotation (viewed at rotor end).....	clockwise
Breaker point opening.....	0.022 in.
Cam angle (degrees with 0.022-in. point opening) ..	31 to 37
Breaker lever spring tension.....	17 to 21 oz
Centrifugal advance :	
Starts at 375 distributor rpm.....	0 to 2.0 deg
Intermediate at 600 distributor rpm.....	5.0 to 7.0 deg
Maximum at 1,000 distributor rpm.....	11.0 to 13.0 deg
Firing order.....	1-5-3-6-2-4

Ignition coil :

Model.....	1915992
Ordinance number.....	7539563
Voltage.....	24

Spark plugs :

Type.....	AC-WR-43
Ordinance number.....	7524258
Size.....	14
Gap.....	0.028 to 0.032 in.

Capacitors (condensers) :

Primary circuit.....	0.25 to 0.35 mfd
Ignition coil.....	0.70 to 1.00 mfd
Breaker point.....	0.18 to 0.23 mfd

## 122. Ignition Timing

*a. General.* Timing the ignition system comprises initial timing; setting the distributor mechanism to cause opening of points at correct firing intervals, and manual advance adjustment; and retarding or advancing the point opening to compensate for various grades of fuel which may be used. These timing factors require checking and adjusting at engine tuneup periods, or when performance of engine necessitates such action. Ignition timing mark is a notch on crankshaft pulley as shown in figure 114. Timing pointer is attached to engine timing gear cover. Due to the sealed design of the ignition system, an adapter is required for connecting timing light (fig. 115).

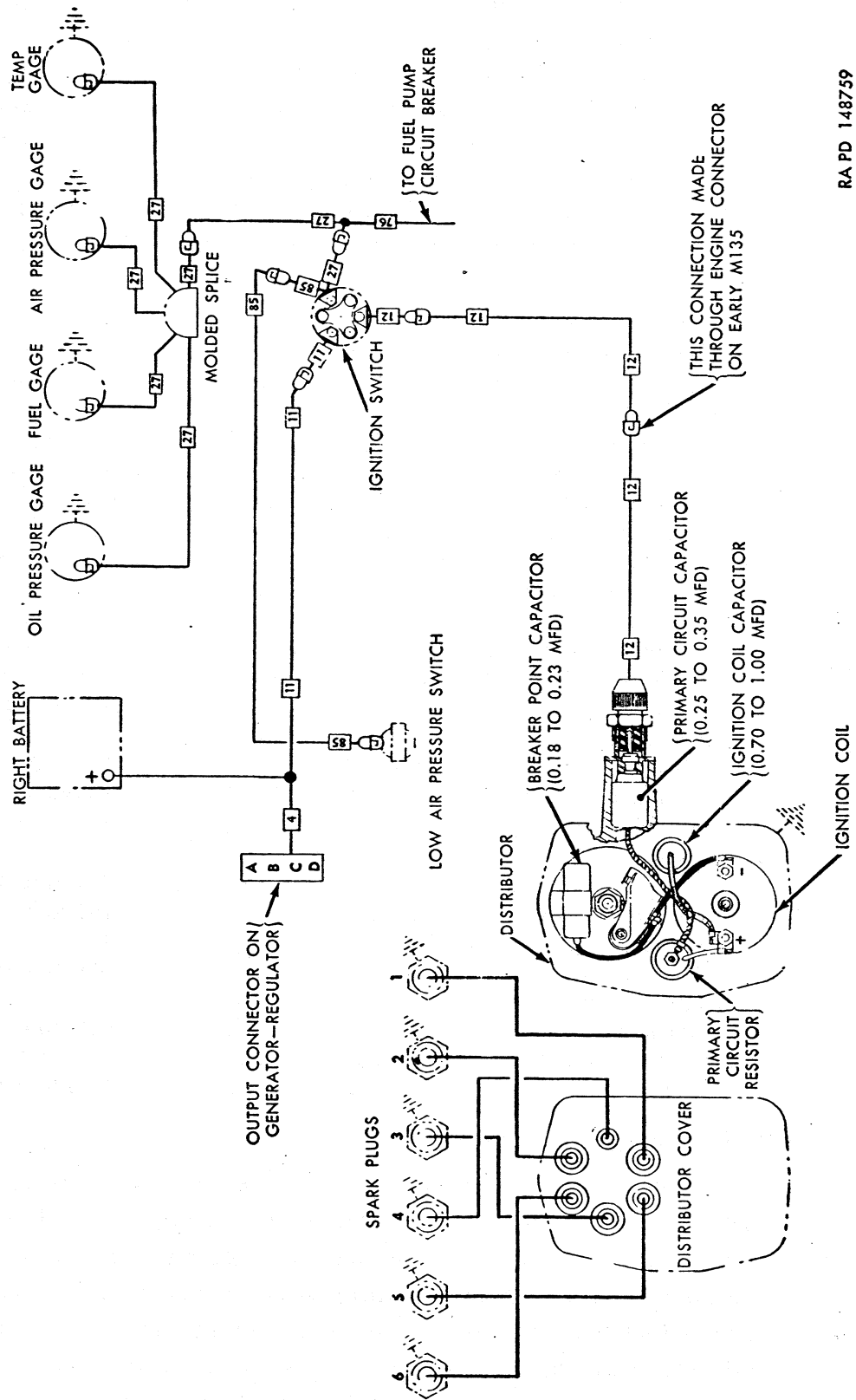
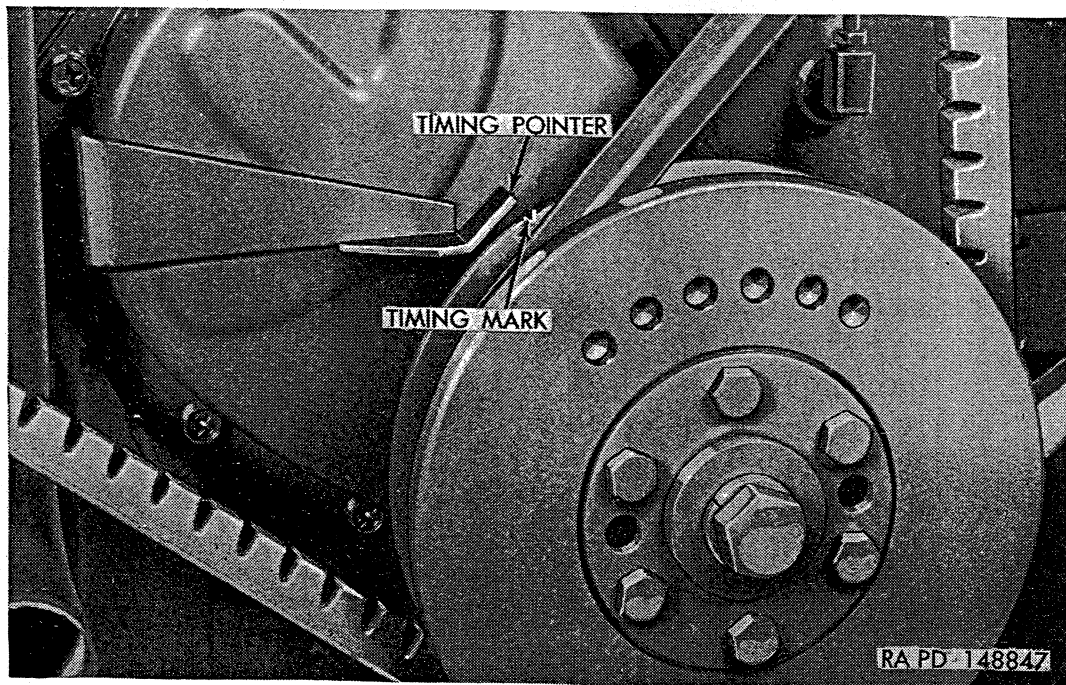

Figure 113. Ignition system circuit diagram.

*b. Initial Timing.*

- (1) Note location of No. 1 spark plug cable in distributor cover and scribe a mark on distributor housing at this point.
- (2) Remove eight screws attaching cover to housing. Remove cover and gasket. Clean and adjust or replace distributor points if necessary (par. 123a or b).
- (3) Make sure distributor is properly installed as follows: do not turn ignition switch on. Slowly turn engine over by intermittently operating starter until timing mark (notch on crankshaft pulley) is alined with timing pointer (fig. 114) on timing gear cover. If rotor segment points toward mark indicating No. 1 spark plug cable location, proceed with (4) below. If rotor points toward No. 6 spark plug cable location, turn engine over one complete revolution until timing mark and pointer are alined and again check position of rotor segment. If rotor segment does not point toward No. 1 spark plug cable location, distributor is improperly installed. Remove distributor and install in correct position (par. 123d and e).
- (4) Install distributor cover, making sure gasket is in place and in good condition. Tighten cover attaching screws.
- (5) Disconnect No. 1 spark plug cable from distributor cover, using crowfoot wrench C7950895 (fig. 76). Thread adapter onto distributor cover; then connect No. 1 spark plug cable to adapter (fig. 115).



*Figure 114. Ignition timing mark and pointer.*

- (6) Connect one terminal of timing light to adapter (fig. 115) and connect other terminal to a convenient ground.
- (7) Start engine and run at a slow idle. Direct beam of timing light toward upper edge of timing pointer (fig. 114) on timing gear cover. Timing light flashes make timing mark on crankshaft pulley appear stationary. Loosen distributor clamp cap screws (fig. 116) and turn distributor housing clockwise or counterclockwise as necessary to synchronize flashes with timing mark when it is aligned with upper edge of pointer. Tighten distributor clamp cap screws.

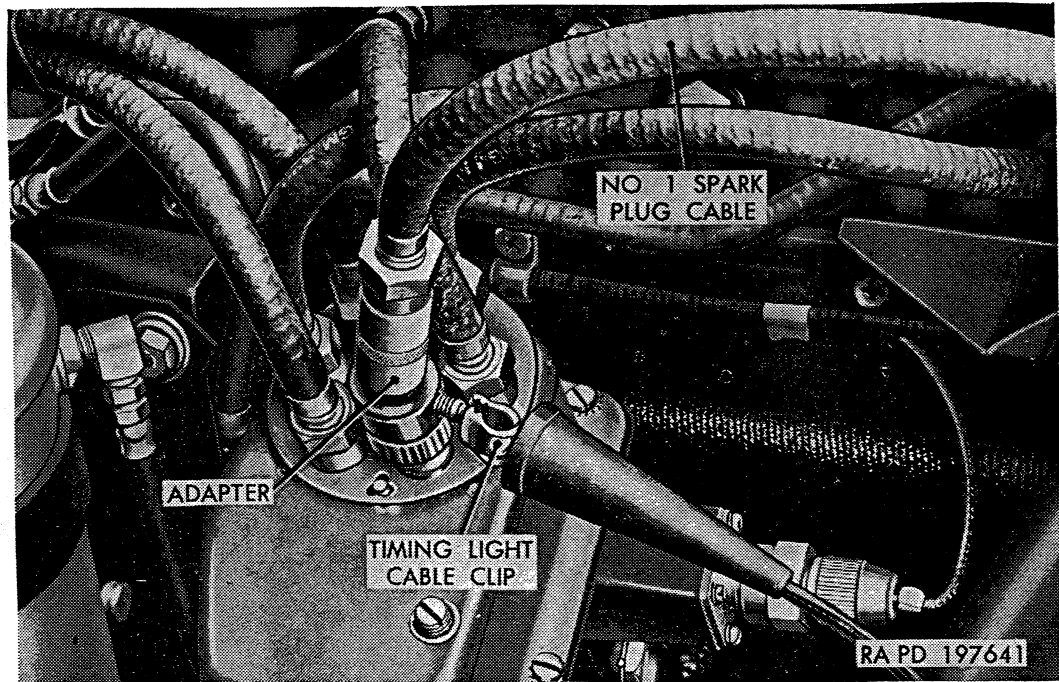

Figure 115. Timing light adapter installed.

- (8) Disconnect No. 1 spark plug cable from adapter and remove adapter; then connect spark plug cable to distributor cover.
- c. *Manual Advance Adjustment.*
- (1) After engine has been thoroughly warmed up, drive the vehicle, using grade of fuel expected to be used in service. Engine should not ping or knock excessively under load and full throttle.
  - (2) A slight amount of ping is not objectionable. If knock is excessive, loosen distributor clamp cap screws (fig. 116) and turn distributor housing clockwise slightly until knock is minimized. Tighten distributor clamp cap screws.

5)  
ng  
m-  
on  
tor  
ng  
ize  
lge

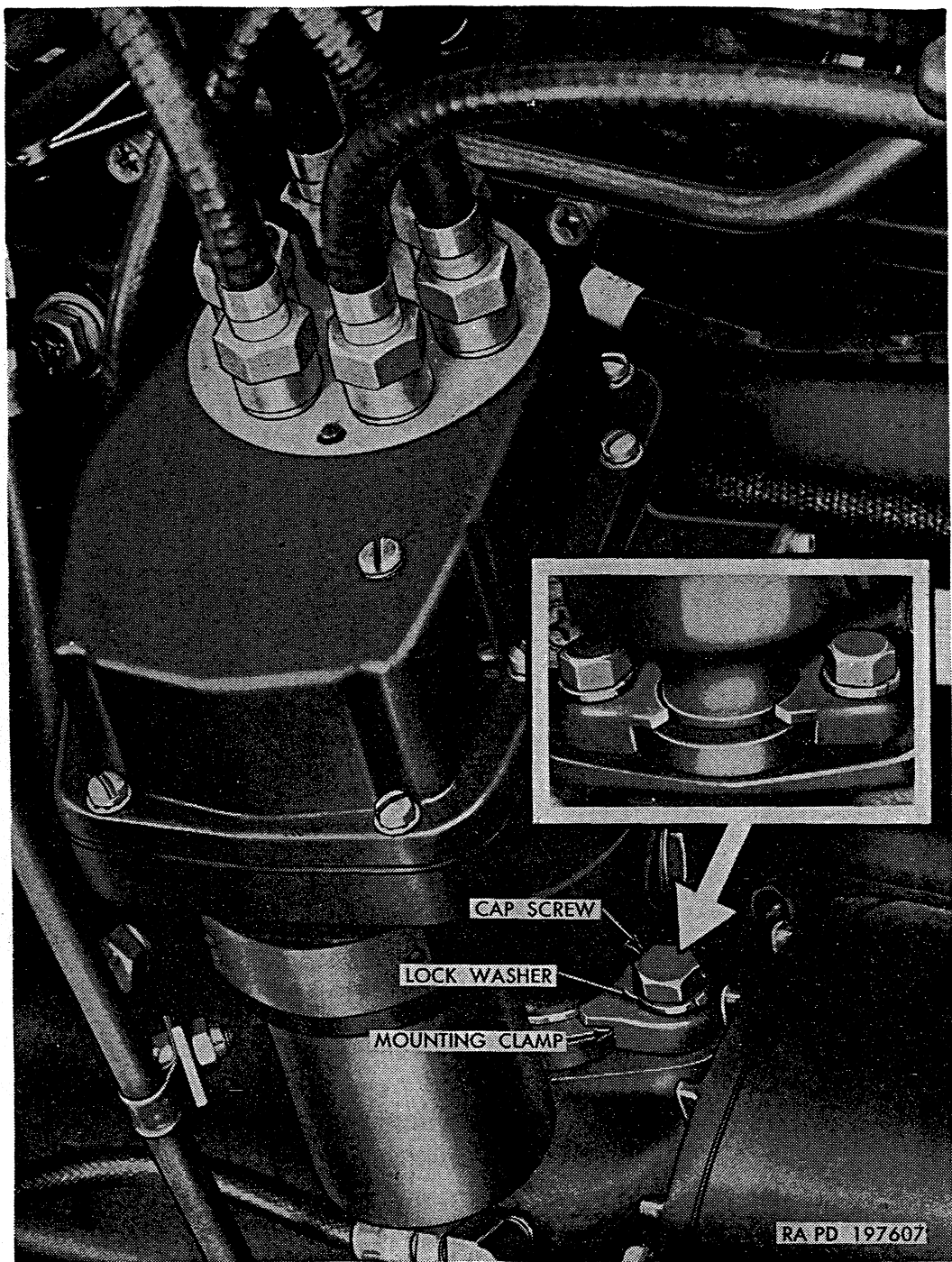

Figure 116. Distributor mounting.

### 123. Distributor and Ignition Coil

#### a. Point Adjustment.

- (1) Remove distributor cover and gasket. Pull rotor off distributor cam. Clean points, using a contact point dresser. If points are badly pitted or burned, replace points (*b* below).
- (2) Turn engine over in small stages by intermittently operating starter until distributor cam comes to rest with breaker lever pad on flat of cam (points closed). Using contact spring



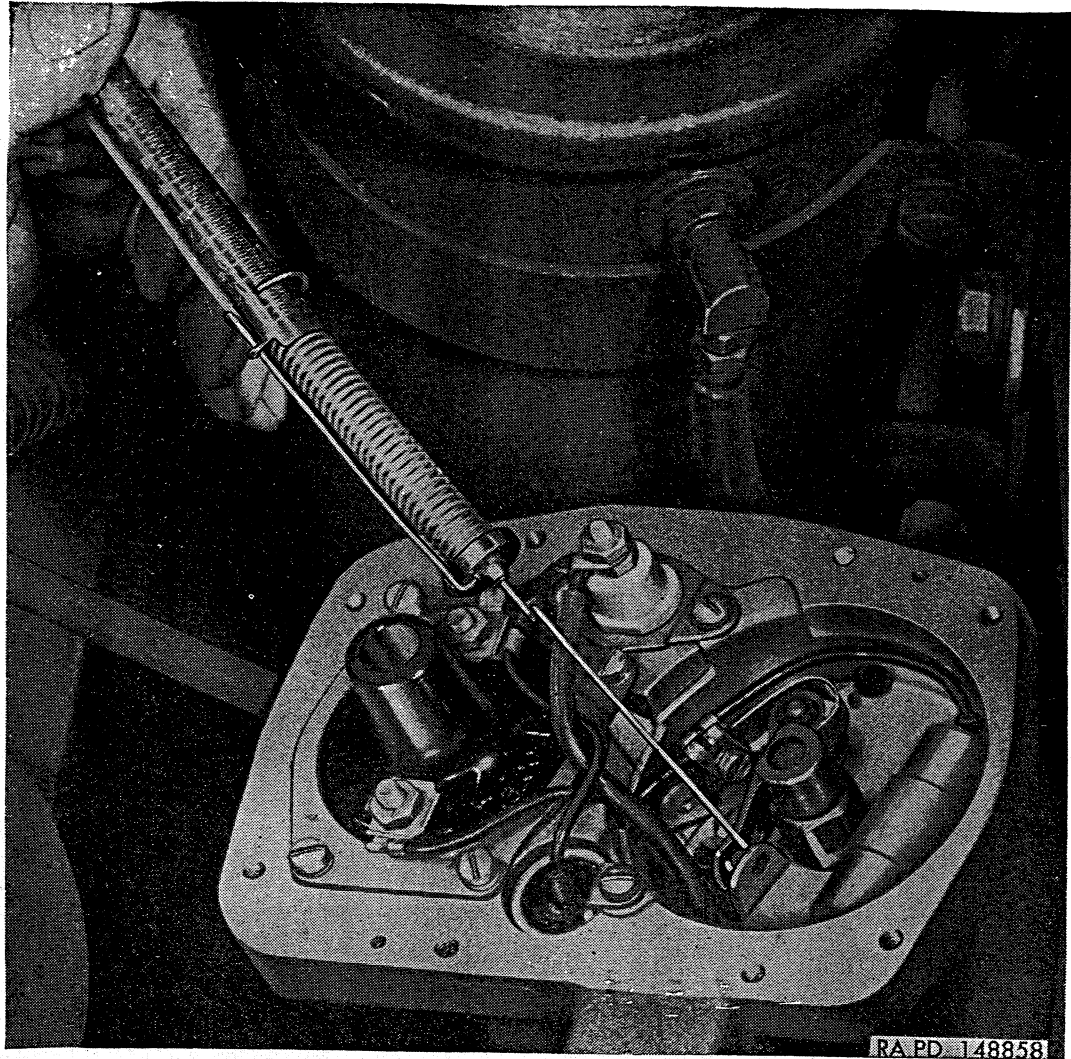

Figure 117. Checking breaker lever spring tension with gage.

gage as shown in figure 117, check pull required to open points. If not within 17 to 21 ounces, adjust spring tension by bending breaker lever spring slightly.

- (3) Turn engine over until distributor cam comes to rest with breaker lever pad on high point on cam (points open). Measure point opening with feeler gage. If not 0.022 inch, loosen clamp screw and turn adjusting screw to obtain opening of 0.022 inch (fig. 118). Tighten clamp screw.
- (4) Install rotor. Install distributor cover, making sure gasket is in place and in good condition.

*b. Point Replacement (fig. 119).*

(1) *Removal.*

- (a) Remove distributor cover and gasket. Pull rotor off distributor cam. Remove clamp screw attaching stationary contact bracket to breaker plate. Lift stationary contact bracket and breaker lever, with cables attached, up off pivot pin.

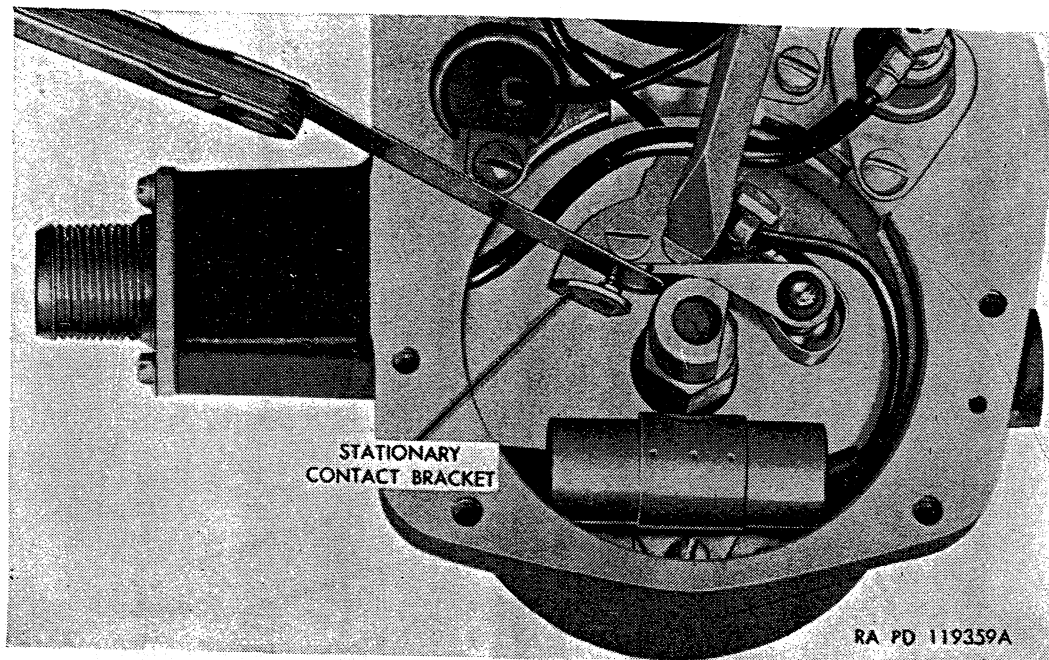
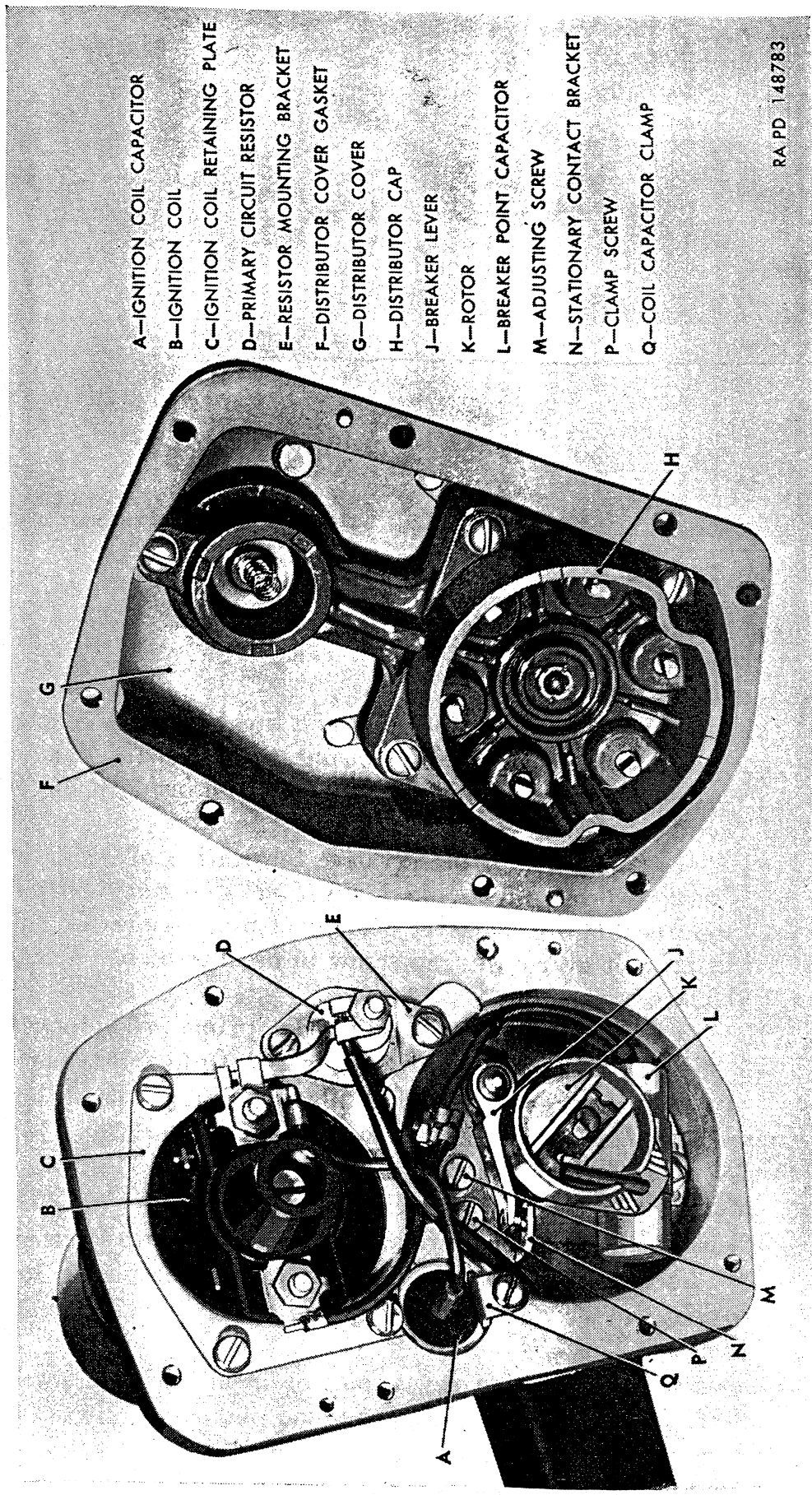

Figure 118. Adjusting distributor points.

- (b) Remove screw and nut attaching cables and breaker lever spring to stationary contact bracket.
- (2) *Installation.*
  - (a) Before positioning new points on breaker plate, connect cables and breaker lever spring to stationary contact bracket. Breaker lever spring must be on inside of lug on contact bracket.
  - (b) Place two drops of preservative lubricating oil (PL) on breaker lever pivot pin. Position stationary contact bracket and breaker lever over pivot pin, with center hole in bracket over adjusting screw in breaker plate. Install clamp screw.
  - (c) Check tension of new breaker lever spring (a(2) above). Adjust point opening (a(3) above). Install distributor cover, making sure gasket is in place and in good condition.
- c. *Breaker Point Capacitor (Condenser) Replacement* (fig. 119).
  - (1) *Removal.* Remove distributor cover and gasket. Pull rotor off distributor cam. Remove nut and screw attaching capacitor lead to stationary contact bracket. Remove screw attaching capacitor mounting bracket to breaker plate. Remove capacitor and bracket; then remove capacitor from bracket.
  - (2) *Installation.* Position new capacitor in mounting bracket. Place capacitor and bracket on breaker plate and attach with screw. Connect capacitor lead, together with coil primary lead and breaker lever spring, to stationary contact bracket.



RA, PD 148783

Figure 119. Distributor with cover removed.

Install rotor, then install distributor cover, making sure gasket is in place and in good condition.

*d. Distributor and Ignition Coil Assembly Removal.*

- (1) Note position of No. 1 spark plug cable on distributor cover and scribe a mark on distributor housing at this point.
- (2) Disconnect spark plug cables from distributor cover, using crowfoot wrench C7950895 (fig. 76); then remove cover and gasket. Disconnect primary circuit cable from front side of distributor housing.
- (3) Turn engine over by intermittently operating starter until notch on crankshaft pulley is alined with pointer (fig. 114) and rotor segment is pointing toward mark on housing indicating No. 1 spark plug cable location.
- (4) Disconnect air vent and vacuum lines from fittings at rear side of distributor housing. Remove two distributor clamp cap screws (fig. 116) and clamps attaching distributor housing to cylinder block.
- (5) Carefully lift distributor straight up out of cylinder block, observing that rotor turns clockwise a few degrees as gears disengage; mark this position of rotor on distributor housing.

*e. Distributor and Ignition Coil Assembly Installation.*

- (1) If engine has not been turned over since removal, proceed as in (a) and (b) below.
  - (a) Remove distributor cover. Turn rotor so segment points to mark made after distributor was withdrawn from cylinder block. If distributor is new, No. 1 firing position of rotor can be determined by marks made on old distributor housing at time of removal.
  - (b) Place new distributor-to-cylinder block gasket on cylinder block. As distributor is lowered into place and gears engage, rotor will turn back (counterclockwise), and should point to No. 1 firing position. It may be necessary to insert the assembly several times to find the correct position to bring rotor to No. 1 firing position.
- (2) If engine has been turned over since distributor removal, remove cylinder head cover from engine (par. 113b). Turn engine over by intermittently operating starter and observe movement of No. 1 intake valve (second valve from front). When No. 1 intake valve starts to close (raise up), continue to turn engine slowly until notch on crankshaft pulley is alined with pointer (fig. 114). Engine is then in No. 1 firing position and distributor may be inserted as directed in (1) above.
- (3) Install two mounting clamps,  $\frac{3}{8}$ -16 x 1 cap screws, and  $\frac{3}{8}$ -inch lockwashers (fig. 116) securing distributor to cylin-



- der block. Connect air bleed and vacuum lines to distributor. Connect primary circuit cable (No. 12) to distributor.
- (4) Check and adjust point opening (*a* above).
  - (5) Install distributor cover, making sure gasket is in place and in good condition. Connect spark plug cables to distributor cover, making sure they are connected to provide correct firing order (1-5-3-6-2-4, fig. 120).
  - (6) Check ignition timing and adjust if necessary (par. 122).

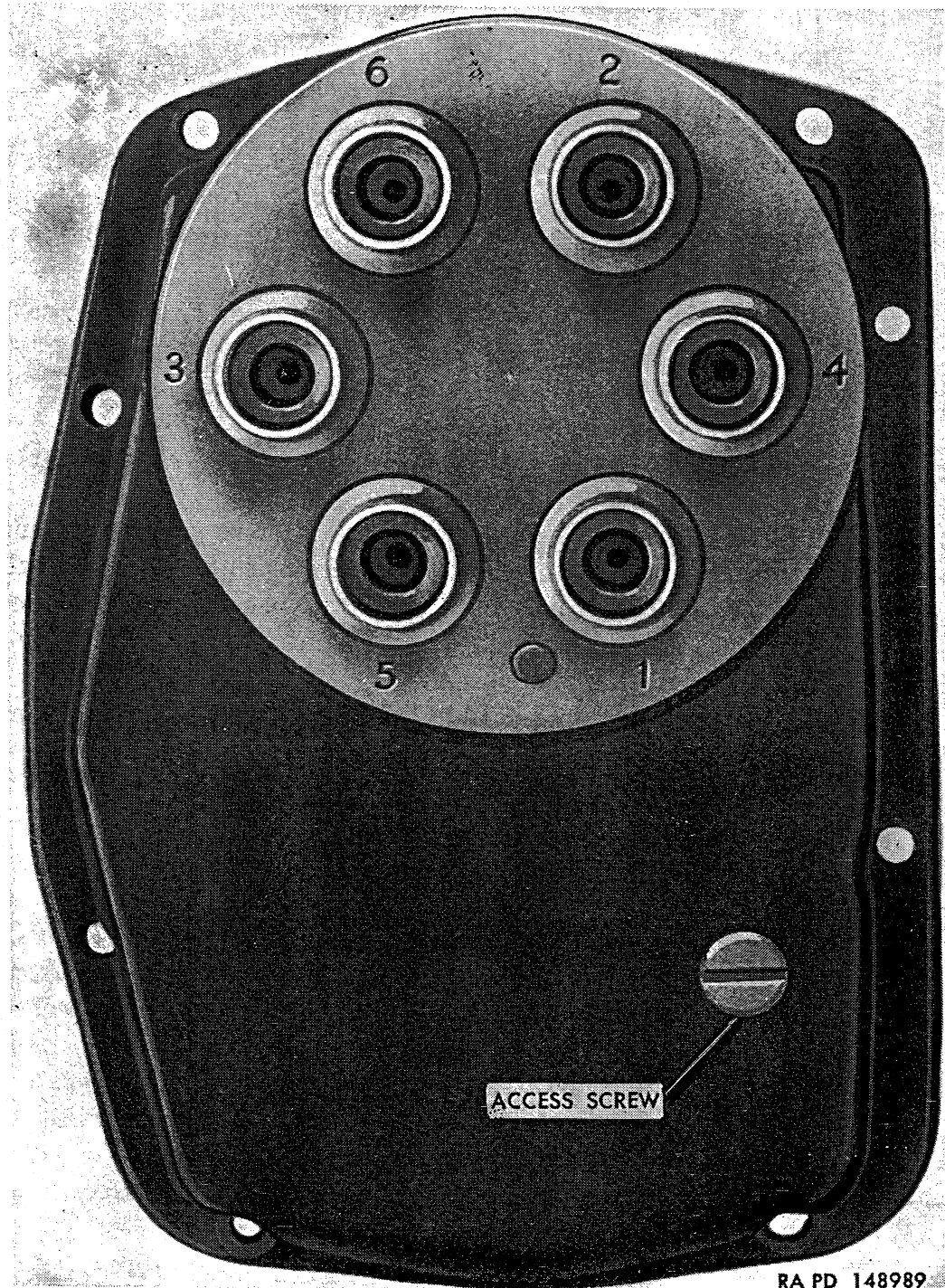

Figure 120. Top view of distributor cover showing firing sequence dial.



f. *Ignition Coil Replacement* (fig. 121).

- (1) *Removal.* Remove distributor cover and gasket. Disconnect cables from coil terminals. Remove four screws attaching coil retaining plate to distributor housing, and remove plate. Lift ignition coil out of housing and remove gasket. Discard gasket.

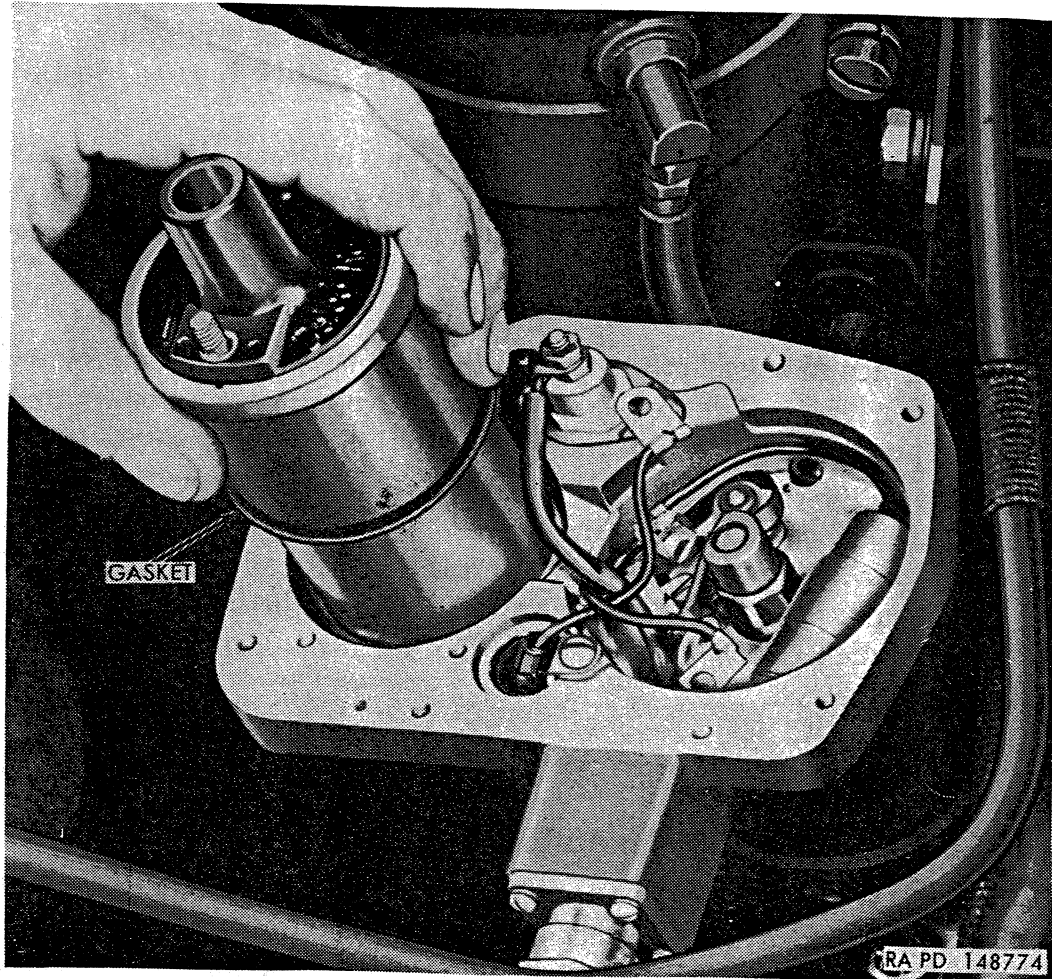

Figure 121. *Removing or installing ignition coil.*

- (2) *Installation.* Place a new gasket on ignition coil and insert coil into distributor housing, with the coil positive (+) terminal next to the primary circuit resistor. Install coil retaining plate and attach with four screw and lockwasher assemblies. Connect lead from stationary contact bracket to coil negative (-) terminal. Connect leads from primary circuit resistor and coil capacitor to coil positive (+) terminal. Install distributor cover, making sure gasket is in place and in good condition.

## 124. Spark Plugs

### a. Removal.

- (1) Disconnect cable from spark plug, using crowfoot wrench C7950895 (fig. 76).
- (2) Using suitable wrench, unscrew spark plug from cylinder head, and remove plug and gasket. Discard gasket.

### b. Cleaning and Adjustment.

- (1) Clean spark plugs, using sandblast cleaning equipment. If electrodes or porcelain insulator are badly burned, install new spark plugs.
- (2) Using a round feeler gage, check gap between electrodes. If not within 0.028 to 0.032 inch, adjust gap to 0.030 inch by bending grounded (side) electrode only. Do not bend center electrode.

### c. Installation.

- (1) Place new gasket on spark plug and thread plug into cylinder head. Be sure gasket does not drop off when positioning plug. Using a suitable wrench, tighten plug to 20 to 25 pound-feet torque. Do not tighten enough to crush gasket.
- (2) Insert spring extending from end of spark plug cable into spark plug shell, press cable in, then thread cable nut onto spark plug shell. Tighten cable handtight, using crowfoot wrench C7950895 (fig. 76). Do not use additional leverage on wrench.

## Section VIII. FUEL AND AIR INTAKE SYSTEM

### 125. Description and Operation

a. *Description.* Units which comprise fuel and air intake system include: carburetor and governor system, carburetor controls, air cleaner assembly, fuel tank and lines, electric fuel pump assembly, and engine primer pump and lines (when used). General arrangement of fuel system major items is shown in figure 122. Manifold heat control and chassis unit vent and breather line system, which is related to fuel and air intake system operation, is also described in this section. Electric fuel gage indicates fuel level in tank.

b. *Operation.* Fuel pump, hanger, and housing assembly, installed in fuel tank, incorporates an electric fuel pump which draws fuel through screen filters mounted on fuel pump housing. Fuel pump discharges fuel into line connected to carburetor bowl inlet fitting which contains a removable filter screen. Engine primer pump, on some vehicles, is installed on instrument panel and when pump is operated, fuel is drawn from tank and discharged through line connected to three primer fittings at intake manifold. Air supply for

carburetor passes through oil-bath air cleaner and is carried through hose which connects air cleaner outlet to inlet elbow on carburetor. Carburetor mixes air and fuel in proper ratio for combustion in engine. Manifold heat control valve serves to direct exhaust gases into intake manifold heat chamber to aid in fuel vaporization in cold weather, or to deflect heat away from intake manifold in hot weather. Valve must be set manually (par. 135).

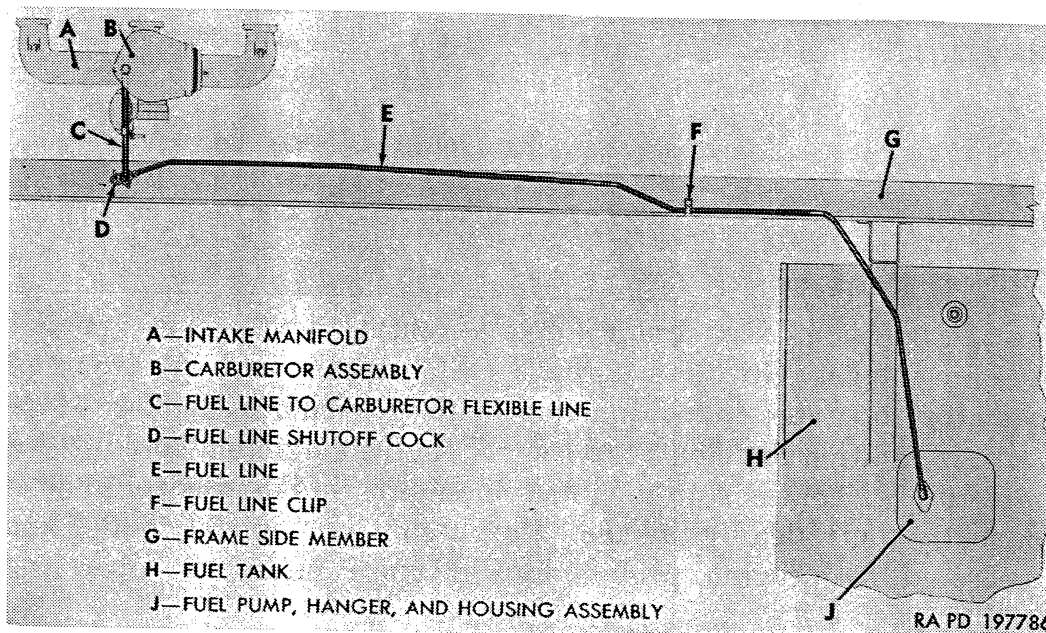

Figure 122. General arrangement of fuel system units.

## 126. Fuel System Data

### a. Carburetor.

Make..... Holley  
 Model..... 885-FFG  
 Number..... R-683-A  
 Engine idling speed..... 375 rpm

### b. Governor (Engine).

Make..... Holley  
 Type..... vacuum activated  
 Maximum governed speed..... 3,300 to 3,400 rpm  
 Governor valve location..... in ignition distributor

### c. Governor (Mechanovac).

Make..... Zenith  
 Maximum governed speed..... 2,200 to 2,250 rpm

### d. Fuel Pump.

Make..... Carter  
 Model..... P-604-S  
 Capacity..... 20 gph  
 Pressure..... 2½ to 3 psi

*e. Fuel Filter.*

Type..... immersion plate  
Make..... Moraine Products  
Location..... in fuel tank

*f. Fuel Tank.*

Capacity..... 56 gal

*g. Fuel Gage.*

Type..... electric  
Make..... AC

*h. Air Cleaner.*

Type..... oil bath  
Make..... AC  
Reservoir capacity..... 2 qt

## 127. Carburetor

*a. Description.* Carburetor is double-venturi, down-draft-type with side air intake. Governor throttle unit, incorporated in carburetor assembly, operates in conjunction with governor centrifugal-type valve in ignition distributor to control engine maximum speed. Carburetor (fig. 124) is stud-mounted on engine intake manifold and is manually controlled by linkage. Carburetor is completely sealed and calibrated to provide proper fuel mixture under all operating conditions.

*b. Adjustments.* One screw is provided at carburetor for setting engine idling speed, and idling mixture is controlled by two adjustable screws (fig. 123). Electric-type tachometer (fig. 190) designed to operate from ignition primary circuit must be available for use in making idling speed adjustment. Vacuum gage must be used as well as tachometer when adjusting carburetor idling mixture.

- (1) *Idling speed adjustment.* Remove access screw from top of ignition distributor cover, install an adapter in place of screw and attach tachometer clamp to adapter (fig. 190). With transmission control lever in neutral and engine temperature within normal operating range (160° to 220° F.), turn idle speed adjusting screw so engine idles at 375 rpm. Remove tachometer clamp and adapter. Install access screw.
- (2) *Idling mixture adjustment.* Connect electric tachometer at ignition distributor as described in (1) above. Remove pipe plug from special elbow in intake manifold below carburetor and attach vacuum gage. Start engine and run until engine temperature reaches 160° to 220° F. Turn idling mixture screws (fig. 123) at rear of carburetor body one at a time to obtain highest reading on vacuum gage with steady indicator. Recheck engine speed indicated on tachometer and readjust

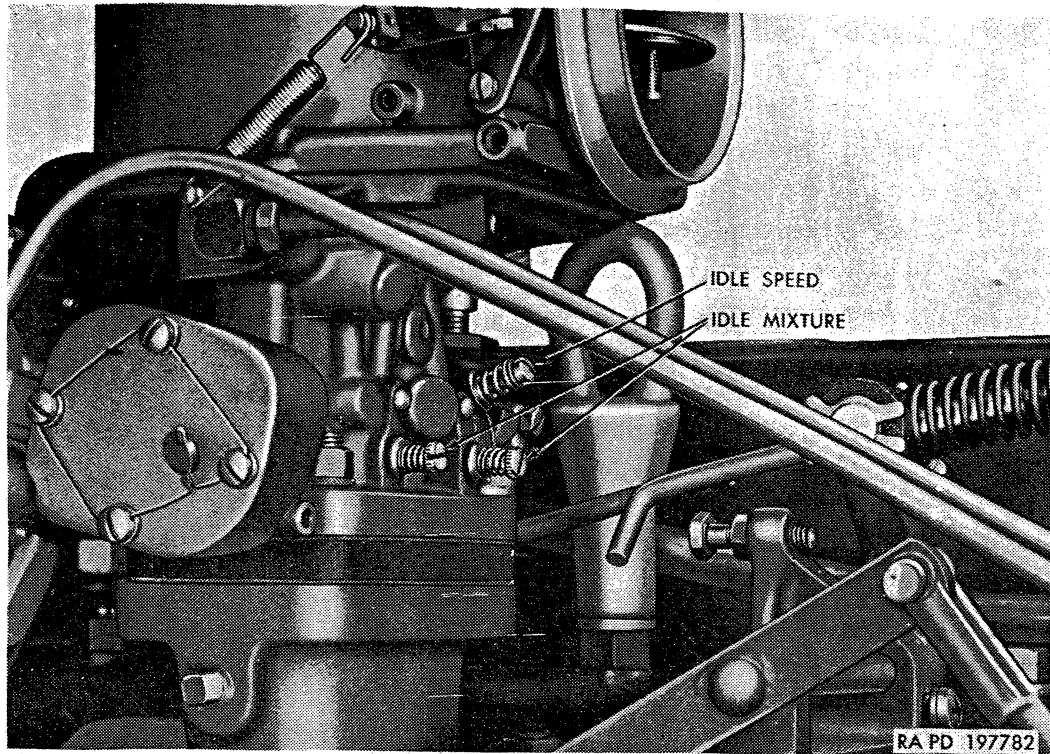

Figure 123. Carburetor adjusting screws.

idling speed if necessary. Remove tachometer, adapter, and vacuum gage. Install tachometer access screw in distributor cover and pipe plug in intake manifold elbow.

*c. Removal.*

- (1) Remove clamp connecting air inlet elbow to carburetor.
- (2) Remove seal wire from vacuum line connector nut at carburetor, and disconnect vacuum line and air bleed line (B and N, fig. 125) at carburetor.
- (3) Disconnect fuel flexible line and line holdup spring from carburetor.
- (4) Disconnect choke control wire at carburetor choke lever (LL, fig. 124) and loosen choke control clip. Remove cross-shaft inner-lever-to-carburetor-lever rod (BB, fig. 124). Remove carburetor mounting studs nuts and lockwashers; then lift carburetor assembly from engine. Discard gasket and seal.

*d. Installation.*

- (1) Place new gasket on each side of insulator on manifold or on Mechanovac unit (if used); then set carburetor in position and install stud nuts and lockwashers on carburetor mounting studs.
- (2) Install cross-shaft inner-lever-to-carburetor-lever rod (BB, fig. 124). Connect choke control wire at choke lever (LL, fig. 124) and tighten choke control clip at choke control clip



- bracket (JJ, fig. 124). Check operation of choke control to be sure valve is open when knob of choke control assembly (A, fig. 124) is pushed in and closes completely with knob pulled out.
- (3) Connect fuel flexible line at carburetor and engage flexible line holdup clip spring at vacuum line elbow of governor. Connect air bleed and vacuum line (B and N, fig. 125) at carburetor. Install seal wire to hold seal in place over vacuum line connector nut.
  - (4) Place new seal at carburetor air inlet flange, position elbow at carburetor, and install clamp to hold elbow to carburetor.

## 128. Carburetor Controls

*Note.* The key letters noted in parentheses are in figure 124, except where otherwise indicated.

*a. General.* Carburetor controls consist of hand-operated choke control and throttle control, and foot-operated accelerator pedal and connecting linkage. Lever at transmission throttle valve (fig. 193 or L, fig. 196) is interconnected with accelerator linkage through adjustable rod.

*b. Choke Control.* Conventional-type wire and housing is used to operate choke valve at carburetor air inlet. Choke control return spring (GG) attached to choke lever (LL) holds choke valve in open position when knob of choke control assembly (A) is released.

### (1) *Removal.*

- (a) Loosen screw at choke lever swivel (HH) and loosen bolt holding housing clip to choke control clip bracket (JJ). Pull control wire and housing from carburetor.
- (b) Remove nut from threaded portion of choke control at instrument panel. Pull choke control assembly out through instrument panel and dash, stripping off nut and lock-washer as control is removed.

### (2) *Installation.*

- (a) Thread choke control assembly through choke nameplate and through hole in instrument panel. Assemble lock-washer and nut on control housing as housing is pushed through panel. Push end of control assembly through rubber grommet in dash and into engine compartment. Hold control and nameplate in place at instrument panel and tighten nut on threaded portion of control at under side of instrument panel.
- (b) Insert lower end of choke control through clip at choke control clip bracket (JJ). Thread control wire through hole in choke lever swivel (HH). Locate control housing to permit choke lever (LL) to move to closed position, then

o  
y  
b  
e  
:  
t  
r  
v  
:  
e  
e  
d  
r  
h  
o  
n  
n  
t  
.  
t  
h  
:  
e  
-  
d  
h  
t  
l  
r  
e  
h  
g  
n

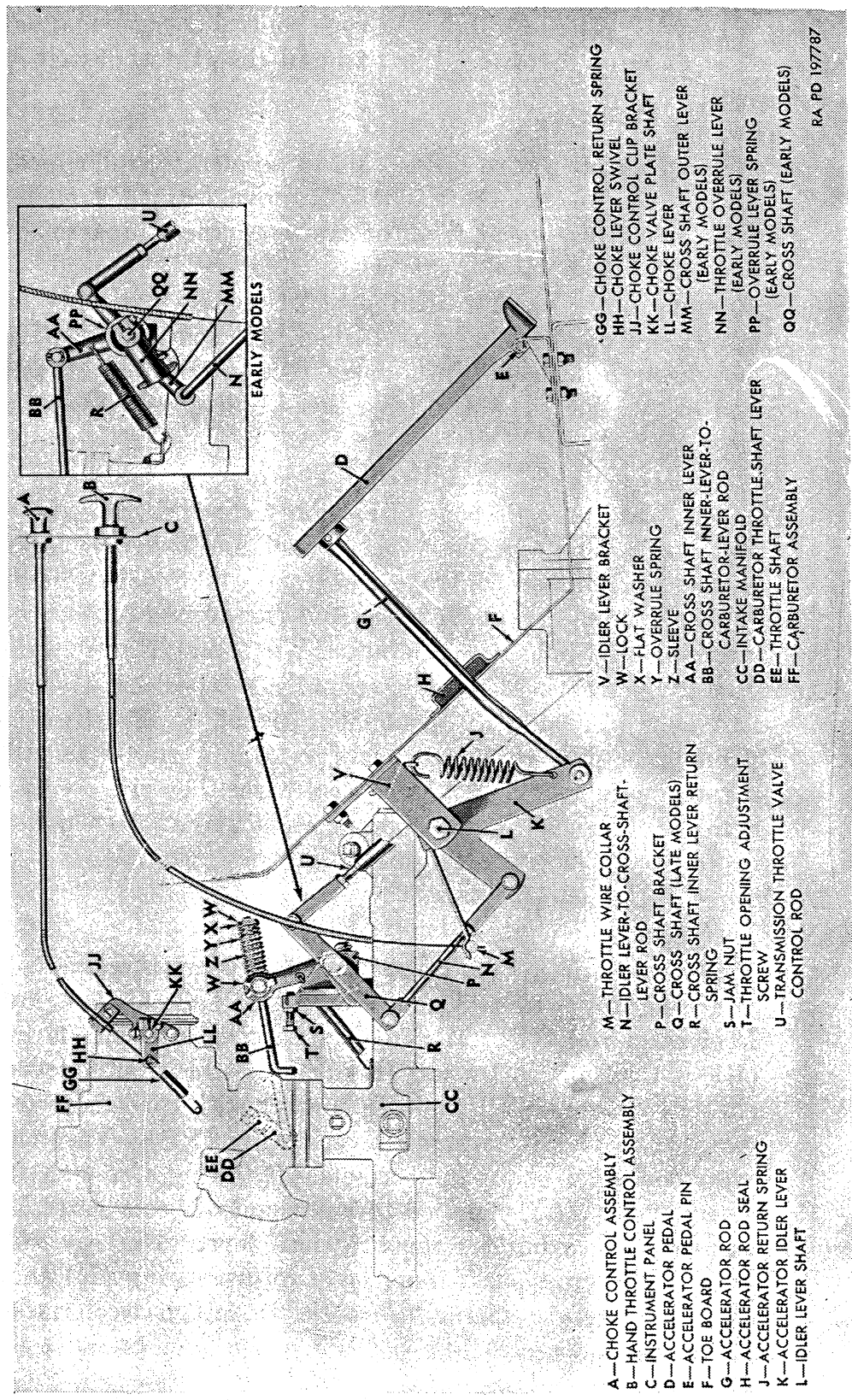

- A—CHOKE CONTROL ASSEMBLY
- B—HAND THROTTLE CONTROL ASSEMBLY
- C—INSTRUMENT PANEL
- D—ACCELERATOR PEDAL
- E—ACCELERATOR PEDAL PIN
- F—TOE BOARD
- G—ACCELERATOR ROD
- H—ACCELERATOR ROD SEAL
- J—ACCELERATOR RETURN SPRING
- K—ACCELERATOR IDLER LEVER
- L—IDLER LEVER SHAFT
- M—THROTTLE WIRE COLLAR
- N—IDLER LEVER-TO-CROSS-SHAFT LEVER ROD
- P—CROSS SHAFT BRACKET
- Q—CROSS SHAFT (LATE MODELS)
- R—CROSS SHAFT INNER LEVER RETURN SPRING
- S—JAM NUT
- T—THROTTLE OPENING ADJUSTMENT SCREW
- U—TRANSMISSION THROTTLE VALVE CONTROL ROD
- V—IDLER LEVER BRACKET
- W—LOCK
- X—FLAT WASHER
- Y—OVERRULE SPRING
- Z—SLEEVE
- AA—CROSS SHAFT INNER LEVER
- BB—CROSS SHAFT INNER-LEVER-TO-CARBURETOR-LEVER ROD
- CC—INTAKE MANIFOLD
- DD—CARBURETOR THROTTLE SHAFT LEVER
- EE—THROTTLE SHAFT
- FF—CARBURETOR ASSEMBLY
- GG—CHOKE CONTROL RETURN SPRING
- HH—CHOKE LEVER SWIVEL
- JJ—CHOKE CONTROL CLIP BRACKET
- KK—CHOKE VALVE PLATE SHAFT
- LL—CHOKE LEVER
- MM—CROSS SHAFT OUTER LEVER (EARLY MODELS)
- NN—THROTTLE OVERRULE LEVER (EARLY MODELS)
- PP—OVERRULE LEVER SPRING (EARLY MODELS)
- QQ—CROSS SHAFT (EARLY MODELS)

RA PD 197787

Figure 124. Carburetor controls.

tighten housing clip bolt. With choke lever in open position, tighten screw to lock wire at choke lever swivel. Check operation of control.

c. *Hand Throttle.* Wire- and housing-type control permits manual operation of carburetor throttle. Use of hand throttle is described in paragraph 21.

(1) *Removal.*

(a) Remove throttle wire collar (M) at accelerator idler lever (K) in engine compartment. Remove control housing from two clips, one at front of cab in engine compartment and one at dash panel inside cab.

(b) Remove nut from threaded part of control assembly at upper end of throttle control, then pull control assembly out through dash and instrument panel, stripping off nut and lockwasher as control is removed. Remove nameplate from control.

(2) *Installation.*

(a) Insert hand throttle control assembly through nameplate and through hole in instrument panel, and assemble lockwasher and nut on control. Push end of control through rubber grommet in dash panel and thread end of control wire through hole in accelerator idler lever (K).

(b) Install lockwasher and nut on threaded portion of control at under side of instrument panel, locate throttle nameplate, and tighten control retaining nut. Install throttle wire collar (M) on control wire; then clip control housing to cab in engine compartment and at dash panel inside cab. Check control operation.

d. *Accelerator Pedal and Linkage.*

(1) *Description.*

(a) *Early models.* Accelerator pedal (D) in cab is connected to accelerator idler lever (K) in engine compartment by accelerator rod (G). Movement of accelerator idler lever (K) is transmitted by rod (N) to cross-shaft outer lever (MM). Outer lever is held in contact with throttle overrule lever (NN) by overrule lever spring (PP). Throttle overrule lever is clamped to cross-shaft (QQ). Cross-shaft inner lever (AA), clamped to right end of cross-shaft, is connected to carburetor throttle shaft lever (DD) by rod (BB). The cross-shaft inner lever return spring (R) and accelerator return spring (J) serve to return accelerator pedal and linkage to idle position when foot pressure is removed from pedal.

(b) *Late models.* Accelerator pedal (D) in cab is connected to accelerator idler lever (K) in engine compartment by

si-  
el.  
al  
ed  
er  
ng  
nt  
at  
ly  
ut  
te  
te  
k-  
gh  
ol  
n-  
le  
ll  
ol  
el  
d  
y  
er  
er  
r-  
le  
ft  
is  
d  
d  
r  
is  
d  
y

accelerator rod (N). Movement of accelerator idler lever (K) is transmitted by rod (N) to lever of cross-shaft (Q). Cross-shaft inner lever (AA) is keyed and clamped to right end of cross-shaft and is connected by rod (B) to carburetor throttle shaft lever (DD). With carburetor throttle plate in full open position, stop on rod (N) contacts throttle opening adjustment screw (T) which is threaded into cross-shaft bracket (P). When accelerator pedal (D) is pressed completely down, cross-shaft inner lever (AA) compresses sleeve (Z) and overrule spring (Y) against flat washer (X) and lock (W) at rear end of carburetor rod (BB), permitting the operation of transmission throttle valve beyond carburetor full throttle opening.

(2) *Removal.* Instructions are given for removing accelerator pedal and linkage progressively, beginning at accelerator pedal. Parts may be replaced individually if so desired.

(a) Remove cotter pin and clevis pin attaching accelerator rod (G) to accelerator pedal (D). Remove accelerator pedal pin (E), and remove pedal.

(b) Remove cotter pin and flat washer attaching accelerator rod (G) to idler lever (K); then remove rod and rod seal (H).

(c) Remove cotter pins and clevis pins from ends of idler-lever-to-cross-shaft-lever rod (N); then remove rod. Unhook and remove throttle wire collar (M) from hand throttle wire. Remove idler lever shaft (L), and remove idler lever (K) from bracket (V).

(d) Remove clevis pin attaching upper clevis end of transmission throttle valve control rod (U) to cross-shaft outer lever (MM) used on early models, or to lever of cross-shaft (Q) used on late models.

(e) Unhook and remove cross-shaft inner lever return spring (R).

(f) On early models, remove cotter pin from each end of cross-shaft inner-lever-to-carburetor-lever rod (BB); then remove rod. On late models, remove cotter pin from carburetor end of rod (BB); then disengage rod from carburetor throttle shaft lever (DD).

(g) Remove two stud nuts and washers attaching cross-shaft bracket (P) to intake manifold (CC). Remove cross-shaft bracket with shaft, levers, and overrule spring as an assembly.

(3) *Installation.*

(a) Place cross-shaft bracket (P), with shaft, overrule spring, and levers assembled, on studs at intake manifold (CC).

Install cross-shaft inner-lever-to-carburetor-lever rod (BB) to carburetor throttle shaft lever (DD) and to cross-shaft inner lever (AA), if rod was removed. Hook cross-shaft inner lever return spring (R) to anchor at manifold stud and into hole of cross-shaft inner lever.

- (b) Using clevis pin and cotter pin, connect transmission throttle valve control rod (U) to cross-shaft outer lever (MM) used on early models, or to lever of cross-shaft (Q) used on late models.
- (c) Assemble accelerator idler lever (K) to idler lever bracket (V), with idler lever shaft (L) retained by cotter pins on early models, or by hex nut on late models. Connect rod (N) to lever (K) with clevis pin, and hook accelerator return spring (J) to lever and anchor. Insert hand throttle control wire through hole in lever (K) and install throttle wire collar (M).
- (d) Place accelerator rod seal (H) with washer at retainer on toeboard (F) and insert accelerator rod (G) through seal and washer; then connect lower end to idler lever (K), using flat washer and cotter pin.
- (e) Install accelerator pedal pin (E) to attach accelerator pedal (D) to pedal bracket at floor. Install clevis pin to connect accelerator rod (G) to pedal. Connect and adjust accelerator and transmission control linkage (par. 202).

## 129. Governor

(fig. 125)

*a. General.* Governor for limiting engine maximum speed consists of two units connected by a vacuum line. A diaphragm unit is incorporated in carburetor assembly and is interconnected with carburetor throttle valve shaft. Other unit consists of a centrifugal-type valve which is part of ignition distributor assembly (P).

*b. Operation.* Air bleed line (N) is installed between distributor and carburetor body, and vacuum line (B) connects passages in diaphragm unit at carburetor with passages at distributor which lead to centrifugal valve assembly (Q). During normal low speed operation, a limited amount of air circulates through air bleed line (N) to distributor, through passage to valve chamber, through valve orifice, and returns to carburetor through vacuum line (B), entering carburetor throat through passages near carburetor throttle plate (K). When engine speed has increased to point at which orifice in centrifugal valve is restricted, vacuum in passages (R) through diaphragm unit (D) begins to act on diaphragm (G). Movement of diaphragm begins to close throttle plate (K); hence driver cannot accelerate engine above speed at which governor mechanism overrules



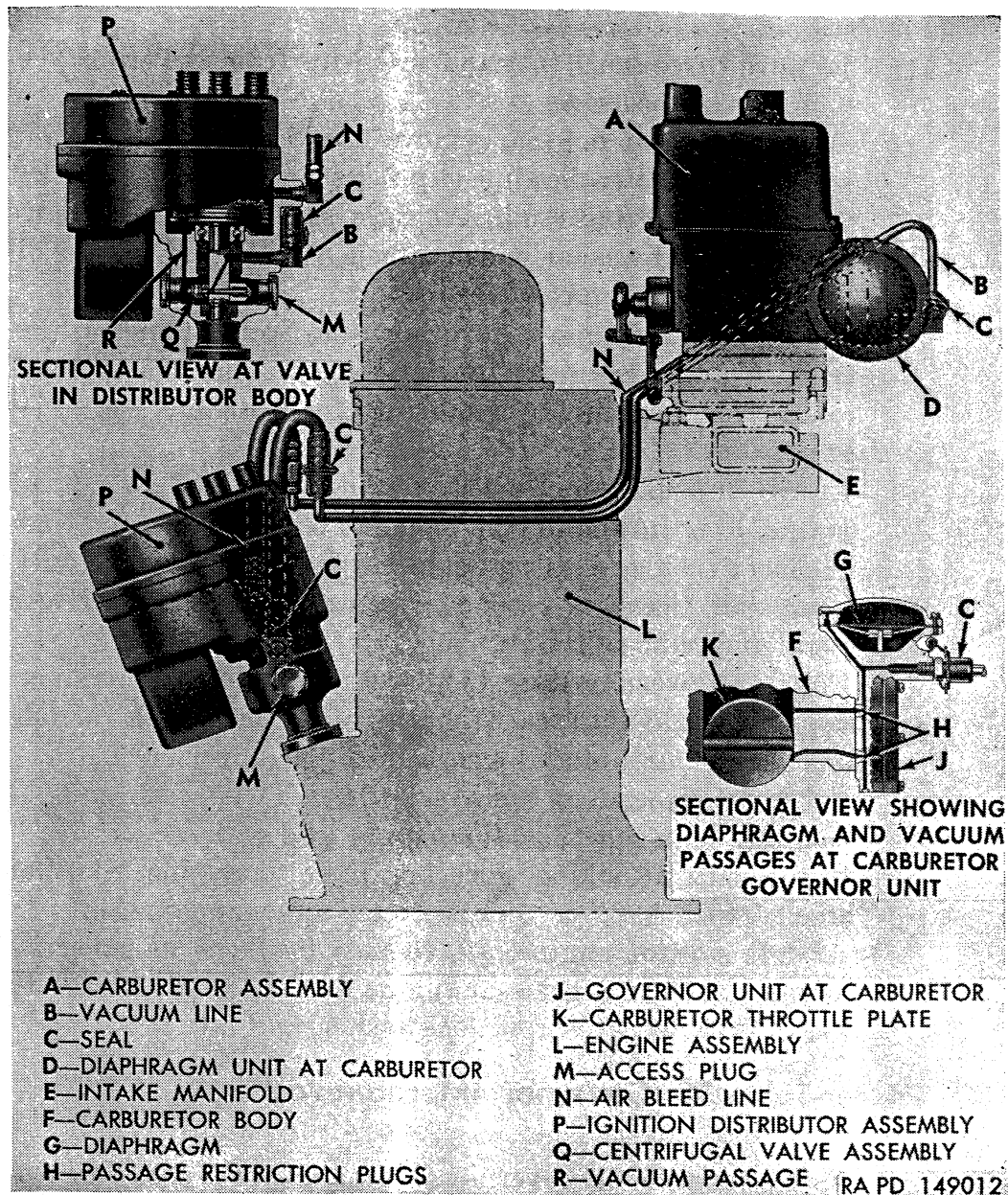

Figure 125. Arrangement of governor units and lines.

manual throttle control. Connection between carburetor throttle valve shaft and diaphragm unit is so designed as to allow diaphragm movement to overrule manual control linkage.

*c. Adjustment.* Valve adjustment at distributor and governor spring calibration at carburetor are set when these units are assembled.

**Caution:** These settings must not be changed, as automatic shifting of transmission will be affected. If the governor action is not correct, condition should be referred to ordnance maintenance personnel, or the distributor and/or the carburetor should be replaced.

*d. Governor Seals.* A seal sleeve and seal wire are installed at each connection in vacuum line. These seals must not be removed except when replacing distributor, carburetor, or governor lines.

(1) *Removal.*

- (a) Remove three seals (C) and seal wire from governor vacuum line connections.
- (b) At left rear of engine, remove one cap screw, nut, and washer which attaches line clip fastener to fastener bracket at engine manifold stud. At right side of engine, remove one screw and washer which attaches line clip to engine oil filter bracket; then remove clip.
- (c) Disconnect and remove governor lines from fittings at distributor and carburetor units. Vacuum line can be separated from vent line by removing clip fastener.

(2) *Installation.*

- (a) Install clip fastener, which retains lines to left side of engine, over lines and line loom. Position governor lines in place; then slide three seal sleeves on vacuum line only. Long seal sleeve is used over center connection between metal and rubber lines.
- (b) Position governor lines in place and install line connections firmly. Wind seal (C) wire one around each vacuum line fitting. Slide seal sleeve into place over each fitting and over one end of each seal wire. Twist both ends of each seal wire together, then apply lead seal.
- (c) Install clip attaching governor lines to engine oil filter bracket with  $\frac{1}{4}$ -28 x  $\frac{3}{4}$  cross-recess screw and washer.
- (d) At left side of engine, attach clip fastener on governor lines to fastener bracket at engine manifold rear stud with one  $\frac{1}{4}$ -28 x  $\frac{3}{4}$  cap screw, lockwasher, and nut.

**130. Power-Take-Off Governor (Mechanovac)**  
(fig. 126)

*a. General.* Power-take-off governor (Mechanovac) is used on gasoline tank truck M217 and water tank truck M222 for the purpose of regulating the engine speed when the accessory drive assembly is in operation. Governor consists of two units: a speed unit which is cable driven from the accessory drive assembly and a throttle slave unit assembly, located between engine intake manifold and the carburetor assembly. Units are connected by a control cable enclosed in a metal tube.

*b. Operation.* When power-take-off accessory drive is in operation, a flexible drive shaft assembly (L) connecting accessory drive assembly and the governor speed unit assembly (H), spins two weights within the speed unit. As the engine speed increases, centrifugal force of the spinning weights is transmitted to the governor throttle slave unit (C) by a spring resisted control cable assembly (G), to open a vacuum control valve in slave unit. Engine manifold vacuum within slave

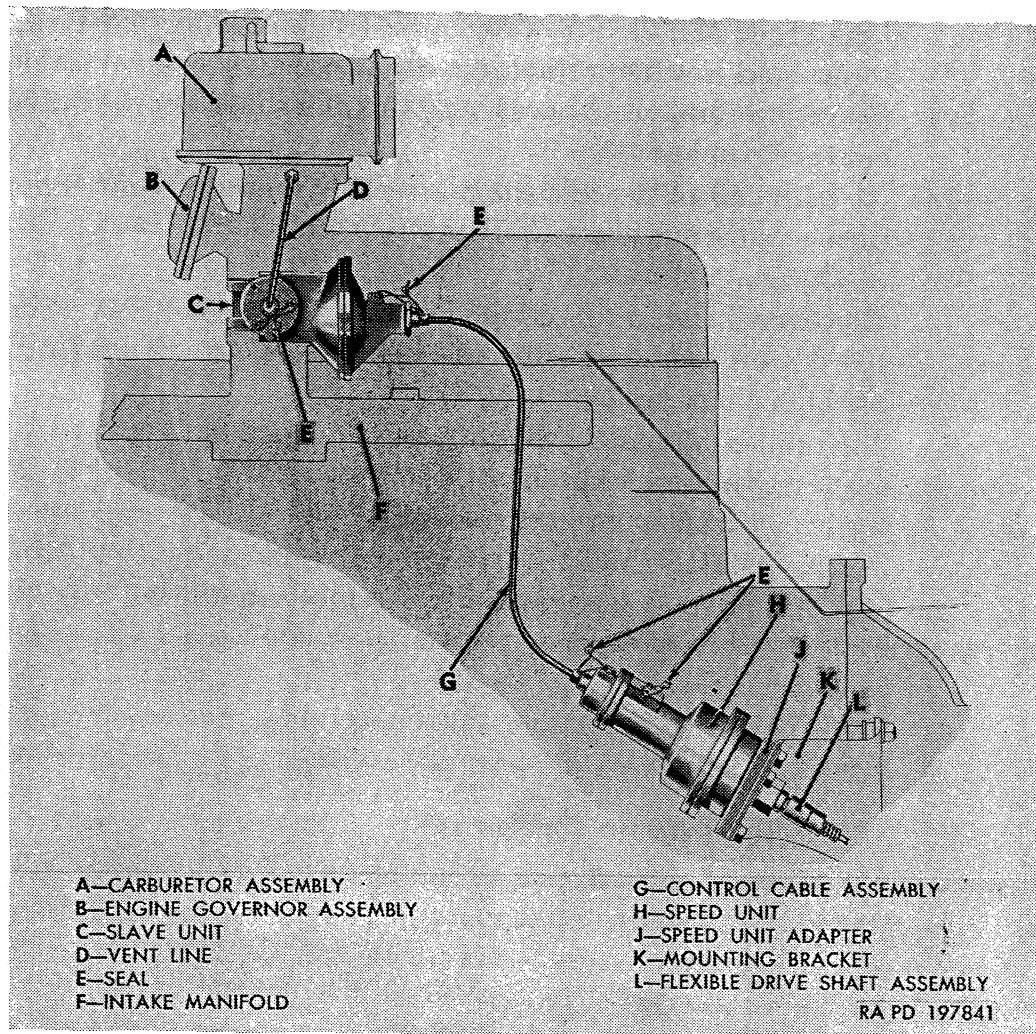

Figure 126. Arrangement of power-take-off governor units and lines.

unit, acting on diaphragm which is connected to the control cable assembly (G), is utilized to control the throttle. The design of the control valve includes a vacuum safety device, whereby if the diaphragm becomes inoperative, the mechanical force alone transmitted by the control cable is sufficient to prevent a runaway engine speed. Adjustment and/or replacement of governor units must be performed only by ordnance maintenance personnel.

*c. Seals.* Governor units are adjusted and sealed, and seals must be removed only when necessary to disconnect lines when replacing carburetor or distributor. Governor seal locations are shown in figure 126.

*d. Flexible Shaft Assembly Replacement.*

(1) *Removal.*

- (a) Remove cap screw and nut attaching flexible shaft assembly rear mounting clip to engine rear support.
- (b) Remove cap screw and washer attaching shaft assembly front mounting clip to brake master cylinder on gasoline

tank truck M217. On water tank truck M222, remove cap screw and washer attaching exhaust valve control cable mounting clip, clip spacer, and flexible shaft clip to brake master cylinder.

(c) At each end of flexible shaft assembly, unscrew shaft nut; then remove shaft assembly.

(2) *Installation.*

(a) Place one end of flexible shaft assembly into governor speed unit and opposite end into accessory drive unit. Tighten shaft nuts.

(b) Install flexible shaft assembly front mounting clip to brake master cylinder with one  $\frac{7}{16}$ -20 x  $\frac{3}{4}$  cap screw and lockwasher on gasoline tank truck M217. On water tank truck M222, install exhaust valve control cable mounting clip, clip spacer, and flexible shaft assembly mounting clip to brake master cylinder with one  $\frac{7}{16}$ -20 x  $1\frac{5}{8}$  cap screw and lockwasher.

(c) Install flexible shaft assembly rear mounting clip to engine rear support with one  $\frac{1}{4}$ -28 x  $\frac{7}{8}$  cap screw and nut.

### 131. Fuel Primer Pump

*a. General.* Fuel primer pump, used only on early cargo truck M135, is installed at instrument panel and connected into fuel line connecting engine intake manifold and the fuel tank. Primer pump can be deactivated as instructed in MWO ORD G749-W2.

*b. Removal.*

(1) Disconnect inlet and outlet lines from engine primer pump assembly. Line connections are under instrument panel.

(2) Hold pump plunger stem from turning by using wrench on flattened portion of stem at knob. Grip knob and turn counterclockwise to remove it from stem.

(3) Loosen hex nut at back side of instrument panel; then, while holding pump barrel with one hand, remove round nut and nameplate from pump.

(4) Remove pump assembly from under instrument panel.

*c. Installation.* When installing new or rebuilt primer pump assembly, the knob and round mounting nut must be removed from pump before pump can be assembled to instrument panel. Refer to pertinent instructions under *b* above for removal of knob and nut.

(1) Hold primer pump with threaded end of pump barrel through hole in instrument panel and place nameplate and round mounting nut on threads. Tighten round nut.

(2) Connect pump inlet line at fitting on side of primer pump. Connect outlet line to fitting at end of pump assembly. Tighten line-to-fitting nuts firmly to prevent leaks.

- (3) Tighten hex nut at back side of instrument panel to lock pump to instrument panel.
- (4) Disconnect primer line at intake manifold and check operation of primer pump.

### 132. Fuel Tank and Lines

*a. Description.* Fuel tank (fig. 127) is supported by brackets bolted on frame at left side of vehicle, and is held in place by straps which pass over top and down outer side of tank and are anchored to supports. Fuel tank is equipped with filler cap and drain plug and is vented to atmosphere through chassis unit vent system (par. 136). Fuel gage sending unit (par. 171*b*) and fuel pump assembly (par. 133) are installed in fuel tank. Fuel lines to supply fuel to carburetor are shown in figure 122.

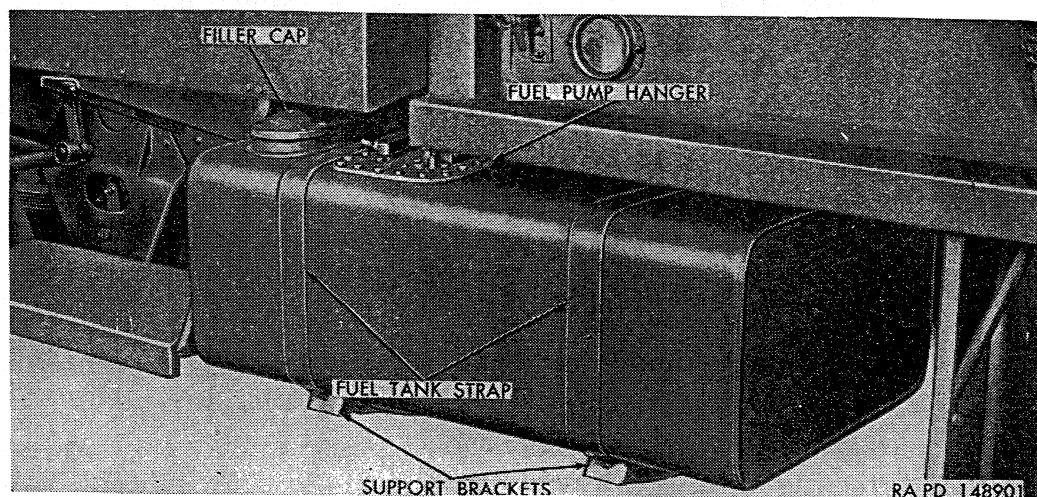

Figure 127. Fuel tank installed.

*b. Filling Fuel Tank* (fig. 128). Fuel tank filler cap assembly incorporates a relief valve which opens at pressure of  $2\frac{1}{2}$  psi. Filler cap is attached to filler tube by chain to prevent loss of cap. Wire mesh screen, located at lower end of metal filler tube, prevents large dirt particles from entering fuel tank.

**Warning:** When filling fuel tank, be sure pump hose nozzle or container is clean, and that dispenser contacts filler neck to carry off static electricity.

- (1) Wipe filler cap and surrounding area with clean cloth before removing filler cap.
- (2) Fill fuel tank with fuel having correct octane rating as indicated on vehicle identification plate (figs. 16-22) attached to instrument panel.

*Note.* Do not overfill fuel tank. Fuel level should be at least 2 inches below tank filler neck to provide space for expansion.



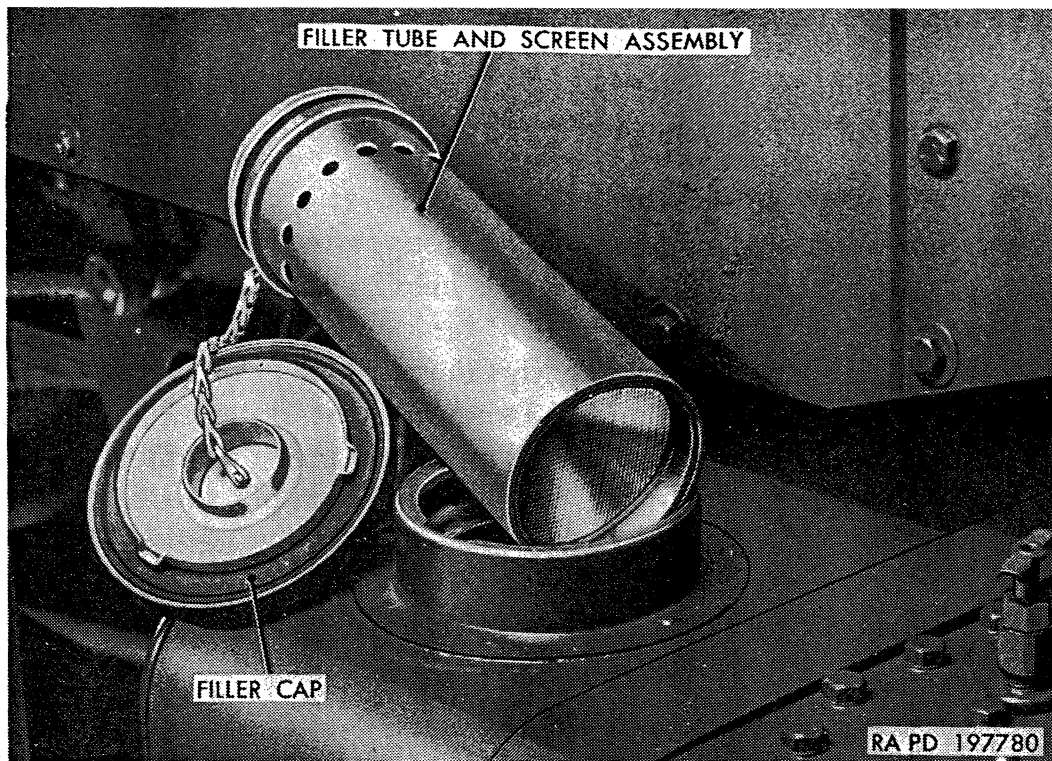

Figure 128. Fuel tank cap, filler tube, and screen.

*c. Draining Fuel Tank.* Provide suitable clean containers with total capacity of approximately 60 gallons.

- (1) Place container under drain opening in bottom of fuel tank and remove drain plug. Clean plug thoroughly. Discard gasket.
- (2) After fuel tank is drained, install drain plug with new drain plug gasket.

**Caution:** Electric fuel pump in fuel tank operates whenever ignition switch is turned on. Do not operate fuel pump for prolonged periods with fuel tank empty as damage to fuel pump may result.

*d. Fuel Tank Replacement.*

- (1) *Removal.*
  - (a) Disconnect fuel outlet line at tank.
  - (b) Disconnect vent line from tank.
  - (c) Disconnect two wiring sockets from fuel pump connector, and one wiring socket from fuel gage sending unit connector. Bend up wiring clip at fuel gage and disengage wiring from clip.
  - (d) Remove nut and washer attaching each fuel tank strap to fuel tank support. On all vehicles, except truck tractor M221, lift up straps; then remove tank from supports.
  - (e) On truck tractor M221, it is necessary to raise and block left end of frame front cover plate approximately 2 inches

to provide fuel tank clearance. Remove four cap screws and nuts attaching cover plate to plate support at frame side member. Raise end of cover plate to provide sufficient height for tank clearance; then block cover plate at frame.

**Caution:** Do not raise end of cover plate to extent of damaging trailer air line and fitting which are fastened to center of cover plate.

Remove fuel tank from supports.

(2) *Installation.*

- (a) Place fuel tank in position on fuel tank supports.
- (b) On truck tractor M221, remove block from between frame cover plate and frame. Install four  $\frac{3}{8}$ -24 x  $1\frac{1}{4}$  cap screws and  $\frac{3}{8}$ -24 nuts attaching frame cover plate to plate support on frame side member. Install four  $\frac{3}{8}$ -24 x  $\frac{7}{8}$  cap screws and  $\frac{3}{8}$ -24 nuts attaching top of fender to cover plate. Tighten all attaching nuts.
- (c) Connect fuel outlet line to fuel tank.
- (d) Connect vent line to fuel tank.
- (e) Connect two wiring sockets to fuel pump connector and connect one wiring socket to fuel gage sending unit connector. Engage wiring in clip at fuel gage sending unit.
- (f) Install  $\frac{3}{8}$ -24 nut and  $\frac{3}{8}$ -inch lockwasher attaching each fuel tank strap to tank supports.

e. *Lines, Shutoff Cock, and Connections.*

- (1) *Description.* Fuel lines, shutoff cock, and connections are shown in figure 122. Fuel line of special metal having inverted flared-type fittings is used for making line connections. Line is clipped in position to prevent vibration and resultant chafing. A flexible line assembly is used between carburetor and fitting at frame left side member. A fuel shutoff cock is installed in fuel line to carburetor. Shutoff cock on early models is located at fuel tank outlet (view B, fig. 129). On late models, fuel shutoff cock is located in engine compartment, mounted in fuel line fitting at frame left side member (view C, fig. 129).
- (2) *Replacement.* Use line of same size and material as original line when making replacement. Install new line in same position and install line clips. When replacing elbows, shutoff cock, and tee connection, coat threads with plastic-type gasket cement before installation.

f. *Fuel Line Shutoff Cock Protector Plate.*

- (1) *Description.* An improvised protector plate (view A, fig. 129) can be fabricated to prevent damage and breakage to fuel shutoff cock on early models (view B, fig. 129). Damage and breakage occurs when operator, in mounting to

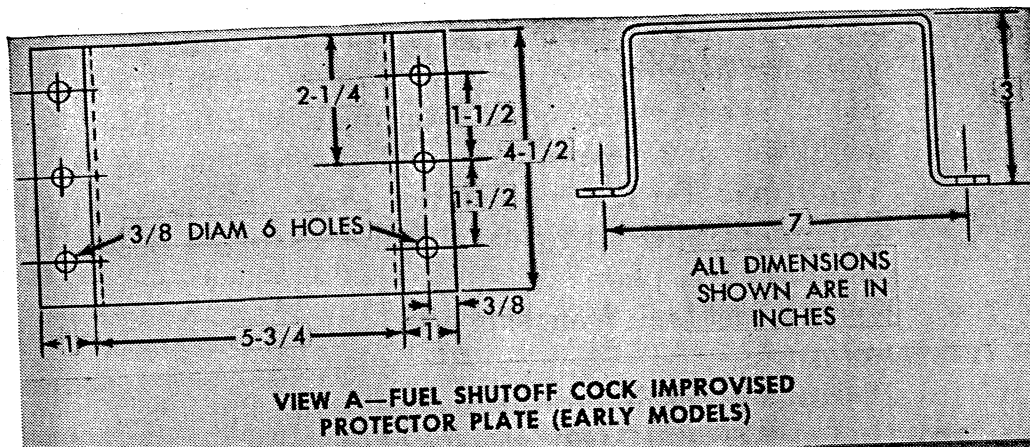

VIEW A—FUEL SHUTOFF COCK IMPROVISED PROTECTOR PLATE (EARLY MODELS)

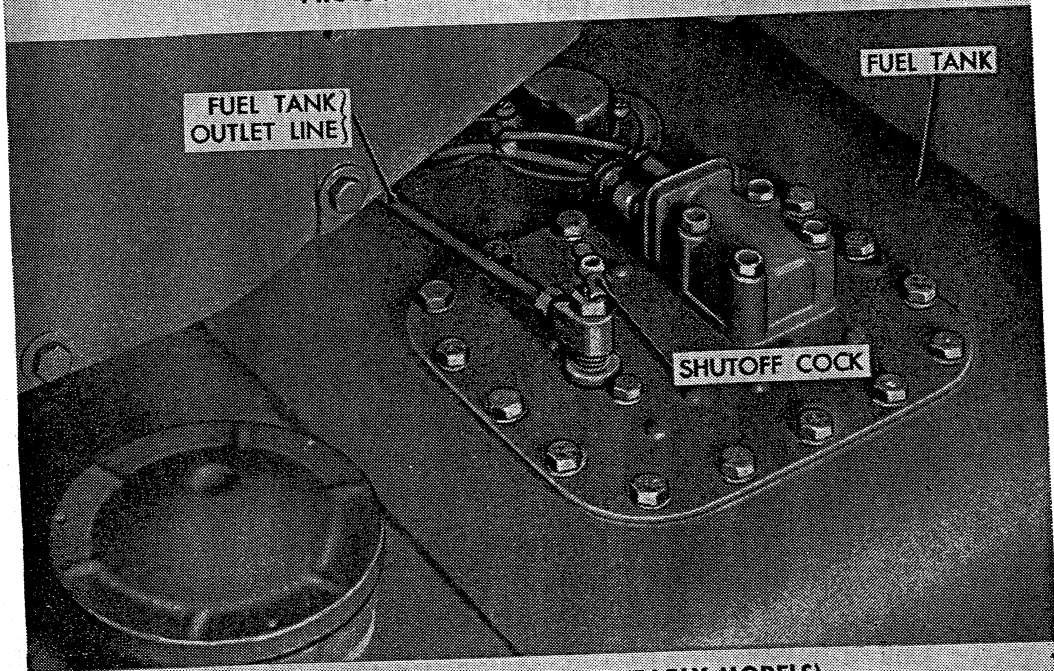

VIEW B—FUEL SHUTOFF COCK (EARLY MODELS)

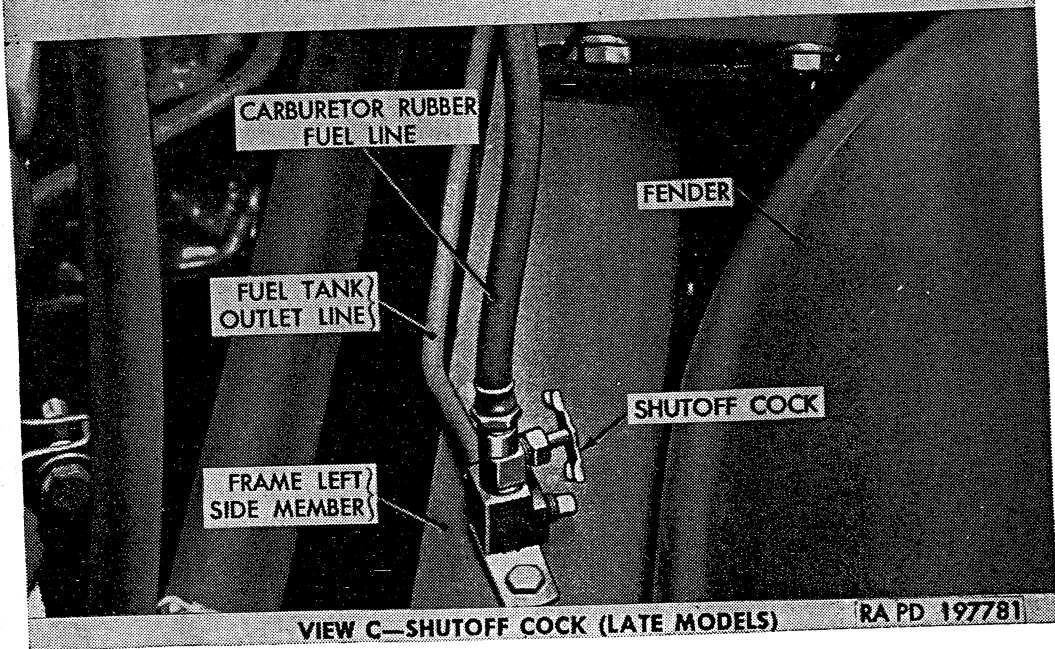

VIEW C—SHUTOFF COCK (LATE MODELS)

RA PD 197781

Figure 129. Fuel line shutoff cock locations and improvised protector plate.

driver's seat, steps on shutoff cock. Protector plate is installed over shutoff cock to flange of fuel pump hanger.

- (2) *Fabrication.* Using approximately 12-gage sheet metal, or suitable substitute, form plate and drill holes as specified in view A, figure 129.
- (3) *Installation.* Remove three cap screws and lockwashers from each side of fuel pump hanger flange. Install protector plate over shutoff cock to flange of fuel pump. Aline holes, then install six cap screws and lockwashers. Tighten cap screws firmly.

### 133. Fuel Pump

*a. Description.* Electric fuel pump is motor driven, centrifugal-type, mounted inside and at bottom of fuel tank. Pump is inclosed inside a metal hanger assembly and a metal housing. Housing is equipped with two screen filters through which fuel must pass before reaching pump. The combined fuel pump and filter assembly is composed of the fuel pump, pump housing, and pump hanger. Hanger with pump and housing is attached to fuel tank with 16 cap screws which hold hanger flange to top of fuel tank. Fuel outlet line connection and electrical connector are located on top of hanger and are accessible at left rear corner of cab.

*b. Cleaning Fuel Pump Filters (fig. 130).*

**Caution:** Before removing fuel pump with pump hanger and housing to gain access to fuel filters, be sure ignition switch is turned off. Also disconnect cables from electrical connector at top of tank and wrap with insulating tape to prevent possibility of electrical spark igniting fumes in fuel tank.

- (1) Disconnect fuel line from fuel outlet fitting.
- (2) Remove 16 cap screws and washers attaching fuel pump hanger to tank.
- (3) Lift fuel pump hanger with pump and housing as a unit from fuel tank.
- (4) Remove four screws and lockwashers attaching each filter frame assembly to the fuel pump housing.

*Note.* Before removing filters, mark outer side of each filter to assure original position of filter when installing.

Remove filter frame, filter, and filter gasket. Discard gasket.

- (5) Wash filters in dry-cleaning solvent or volatile mineral spirits.
- (6) Install filter gasket, filter, and filter frame to fuel tank in sequence stated, with four No. 10-32 x  $\frac{7}{16}$  screws and lockwashers.
- (7) Place new gasket at opening in fuel tank, then lower hanger, housing, and pump assembly into tank. Install sixteen

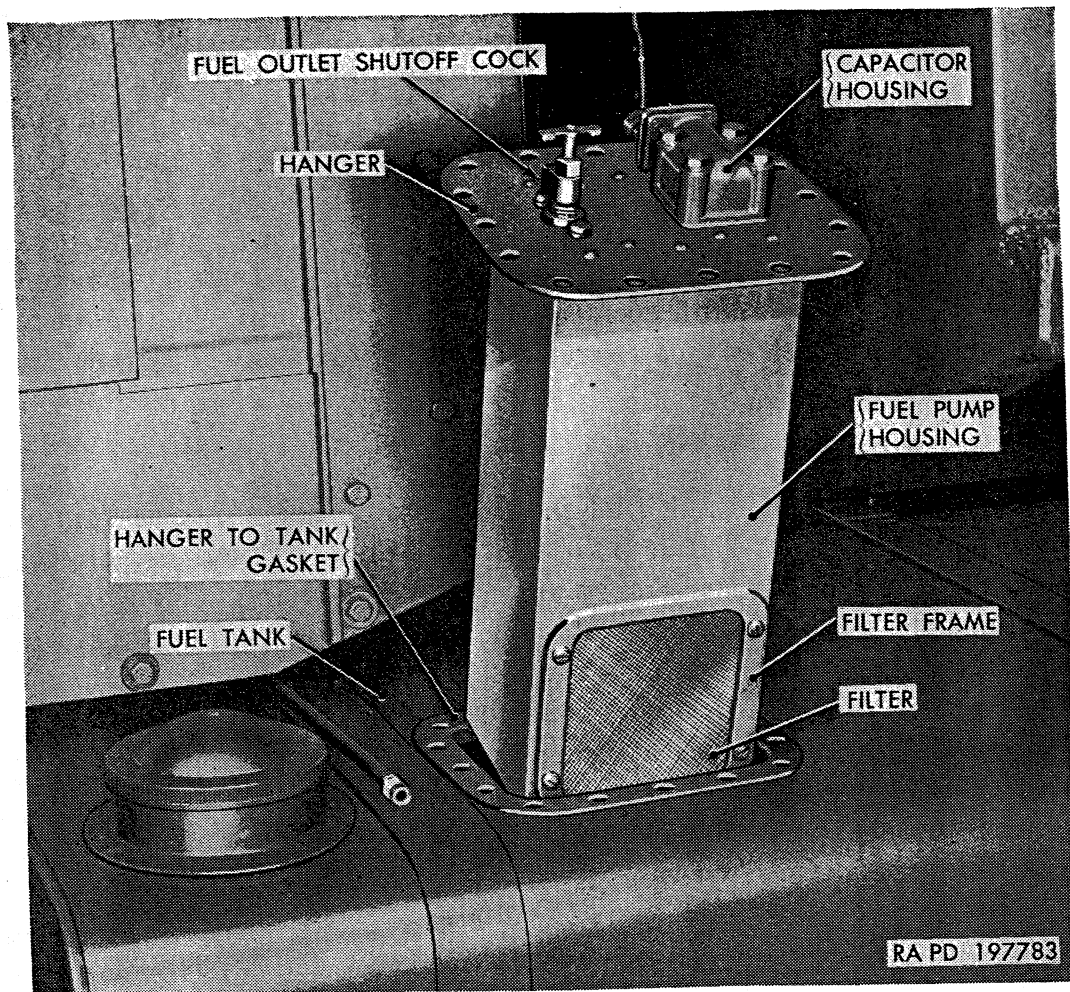

Figure 130. Fuel pump, hanger, and housing removed, exposing fuel filters.

$\frac{5}{16}$ -24 x  $\frac{3}{4}$  cap screws with  $\frac{21}{64}$ -inch copper washers attaching fuel pump hanger flange to tank.

- (8) Connect fuel line to fuel tank outlet fitting. Connect electrical wiring at connectors.

*c. Testing.* Test fuel pump pressure (par. 126*d*) with pump installed in tank and with tank at least one-quarter full of fuel. Pressure gage, line, and adapter for connecting gage to fuel outlet fitting at fuel tank are required to perform test.

- (1) With ignition switch turned off, disconnect fuel line from fuel outlet fitting at tank. Connect pressure gage to fitting.
- (2) Turn ignition switch on and observe reading on gage. For satisfactory operation, pressure should be  $2\frac{1}{2}$  to 3 pounds.

*Note.* If fuel pump pressure is low, check condition of batteries (par. 159) and be sure electrical connections in fuel pump circuit are clean and tight.

- (3) Low pressure may be caused by clogged filters at fuel pump housing. Refer to *b* above for instructions for cleaning filters.



## 134. Air Cleaners

(fig. 131)

*a. Description.* Carburetor air cleaner is oil-bath type. Mounting bracket band (J) is clamped around air cleaner assembly to bracket on front side of dash panel. Air cleaner outer shell is bolted to air cleaner manifold (A) which is bolted to dash panel. Air cleaner oil base (K) is held to bottom of cleaner by four catch springs (M) on early models only. On late models, a single cable assembly (L) retains oil base to bottom of cleaner. A flexible hose (G) connects air cleaner manifold to carburetor inlet elbow.

*b. Servicing.* Service carburetor air cleaner as directed below, referring to lubrication chart (par. 69) for intervals and type of lubricant.

- (1) *Disassembly.* Remove reservoir oil base (K) by releasing four catch springs (M) on early models, or by releasing cable assembly (L) on late models. Pull cleaner element downward to remove from body of cleaner.
- (2) *Cleaning.* Pour oil from reservoir base. Clean reservoir base and element, using dry-cleaning solvent or volatile mineral spirits to remove all old lubricant and dirt. Permit element to dry thoroughly.

**Caution:** Do not use compressed air on element.

- (3) *Assembly.* Install element in cleaner body. Fill reservoir oil base (K) to OIL LEVEL mark; then install reservoir oil base and fasten in place with four catch springs (M) on early models, or with cable assembly (L) on late models.

*c. Removal.*

- (1) Loosen air-cleaner-to-carburetor hose clamp (F) and pull hose (G) off manifold outlet. Disconnect brake power cylinder vent line (B) from elbow on top of air cleaner manifold.
- (2) Remove five nuts and lockwashers from manifold-to-dash panel attaching cap screws (C). Support air cleaner assembly while removing clamp bolt (N); then remove assembly from engine compartment. Remove gasket from cap screws at dash panel. Air cleaner mounting band and bracket may be removed after four cap screws (P) have been removed.

*d. Installation.*

- (1) Install mounting bracket with mounting bracket band (J) on dash panel with four  $\frac{3}{8}$ -24 x  $\frac{3}{4}$  cap screws (P),  $\frac{3}{8}$ -24 nuts, and  $\frac{3}{8}$ -inch lockwashers.
- (2) Set air cleaner assembly in place at mounting bracket with gasket between manifold and dash panel. Install five  $\frac{5}{16}$ -24 x  $1\frac{1}{8}$  manifold-to-dash panel cap screws (C),  $\frac{5}{16}$ -24 nuts,



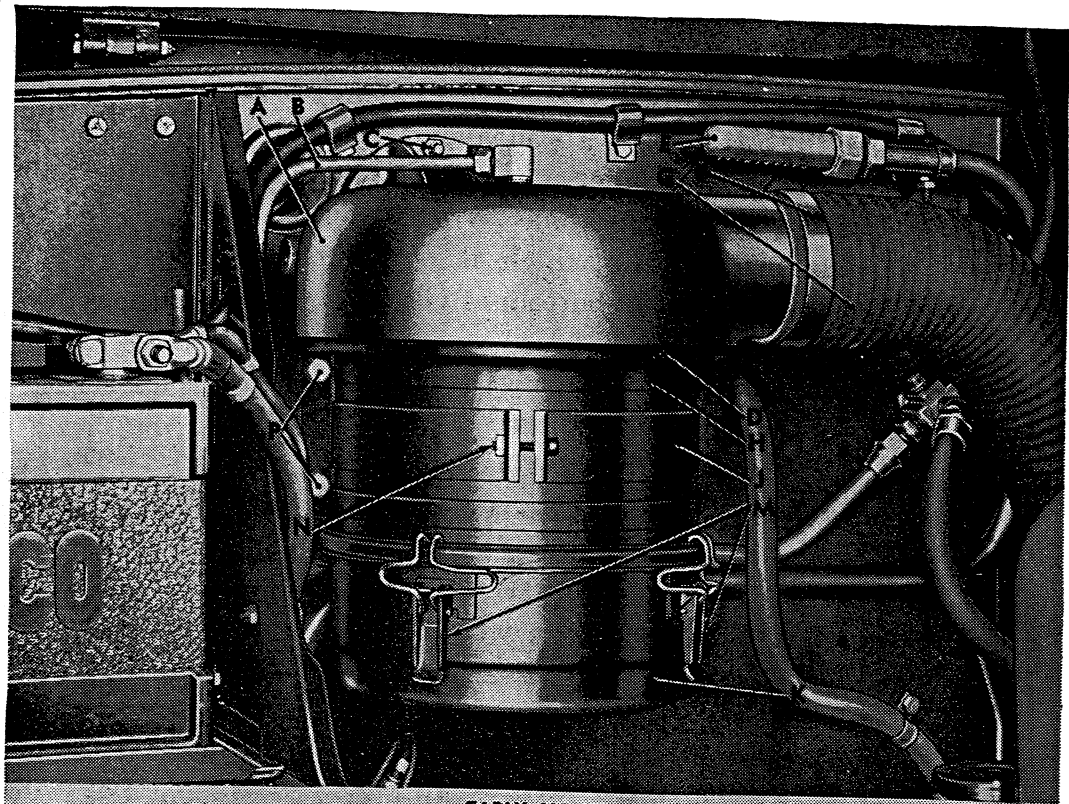

EARLY MODELS

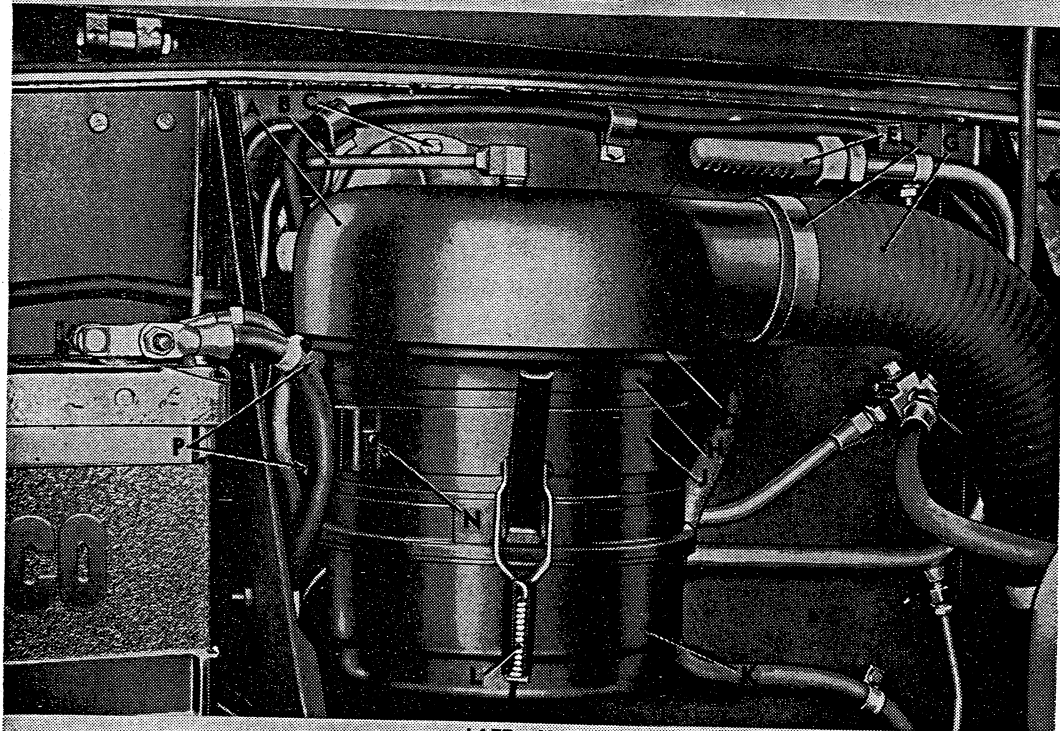

LATE MODELS

- A—AIR CLEANER MANIFOLD
- B—BRAKE POWER CYLINDER VENT LINE
- C—CAP SCREW
- D—AIR CLEANER TO MANIFOLD OUTER GASKET
- E—CHASSIS UNIT BREATHER
- F—HOSE CLAMP
- G—AIR CLEANER TO CARBURETOR INLET HOSE

- H—AIR CLEANER SHELL
- J—MOUNTING BRACKET BAND
- K—OIL BASE
- L—CABLE ASSEMBLY
- M—CATCH SPRING
- N—BOLT
- P—CAP SCREW

RA PD 197788

Figure 131. Air cleaner installed.

and  $\frac{5}{16}$ -inch lockwashers which attach manifold to front side of dash panel.

- (3) Install and tighten clamp bolt (N) at mounting bracket band (J).
- (4) Attach inlet hose (G) to manifold outlet and tighten air-cleaner-to-carburetor hose clamp (F).
- (5) Connect brake power cylinder vent line (B) to elbow on top of air cleaner manifold.
- (6) Check oil level in reservoir oil base (K).

### 135. Manifold Heat Control Adjustment

*a. General.* Adjustable valve in exhaust manifold is provided to control temperature at intake manifold center section where incoming fuel mixture is preheated. There are three positions for heat control lever (E, fig. 132). Correct setting is important to efficient engine operation and fuel economy.

*b. Adjustment.* Manifold heat control valve adjustment must be made manually. Two extreme positions are indicated by arrows on lever as ON and OFF. Intermediate setting is obtained by locating lever at detent in casting halfway between extreme positions. Set screw and locknut in lever hold lever in desired position. Tighten

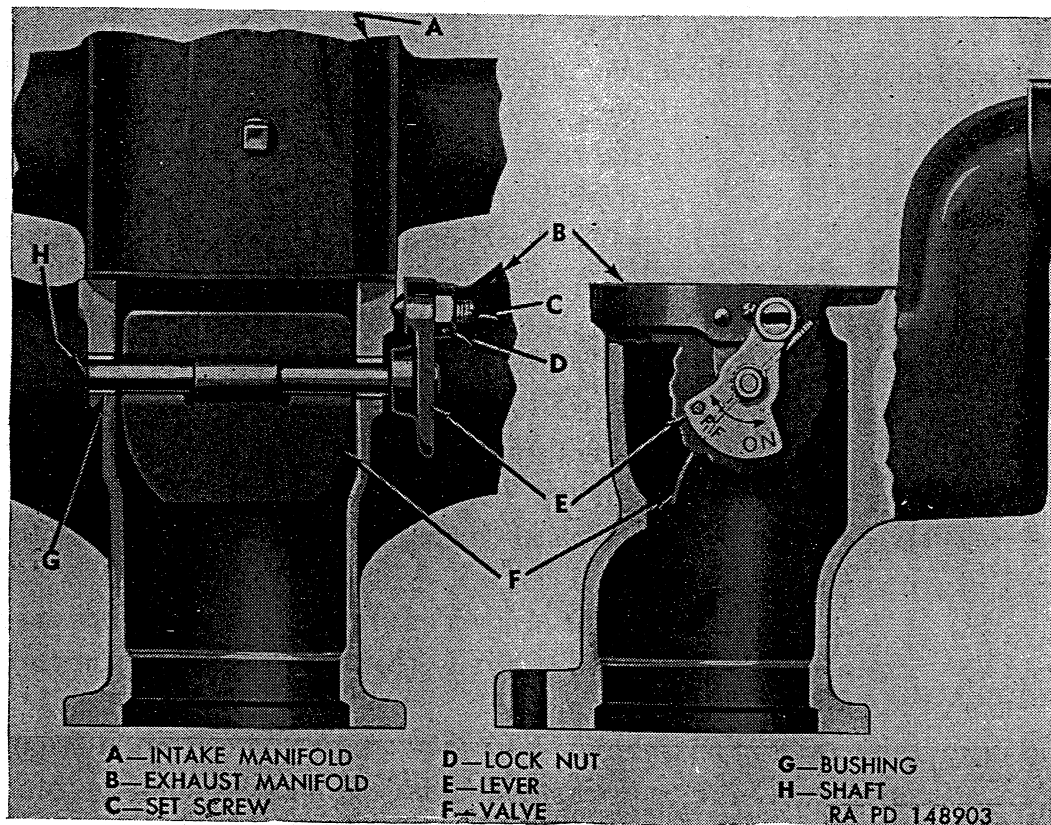

Figure 132. Manifold heat control.

setscrew only enough to prevent rattling; overtightening may distort valve lever or shaft. Tighten locknut after adjustment is completed.

*Note.* It is not expected that control valve setting be changed each time conditions vary. Valve should be set for average operating conditions consistent with air temperature.

- (1) *Summer operation.* At air temperature of 60° F. or above, adjust valve lever to OFF position.
- (2) *Winter operation.* At air temperature of 30° F. and below, adjust valve to ON position.
- (3) *Spring and fall operation.* At air temperature of 30° to 60° F. and also at lower temperatures when in heavy duty operation (heavy loads, high speeds, and extensive operation in lower gear range), adjust valve lever to intermediate position.

*Note.* Intermediate position should be used whenever OFF position does not furnish sufficient heat or if ON position supplies too much heat, depending on type of operation or weather conditions.

### **136. Unit Vent and Breather Lines and Connections**

*a. Description.* All vehicles are equipped with a system of lines for venting various chassis units to atmosphere. Small lines connected to individual chassis units lead to larger line which is mounted at frame right side member. Another large vent line assembly is installed in engine compartment on cab dash panel, and is connected by flexible line to large vent line on frame. Vent line of dash panel opens into separate chassis unit breather (E, fig. 131) located near top front center of dash panel. Following is a list of units which are connected to vent system: rear rear axle, forward rear axle, transfer, fuel tank, transmission, front axle, and brake master cylinder. In addition to units mentioned above, engine flywheel housing and crankcase breather are connected to vent line on dash panel by flexible line attached to tee fitting near No. 6 spark plug and nipple on vent line at dash panel.

#### *b. Lines and Connections.*

- (1) *Axle vent lines.* Hydraulic fluid lines and vent lines are attached to each axle assembly at a junction with threaded openings for attaching lines. Flexible lines supported at axle upper torque rods are used to connect axle air vent lines to fitting at frame.
- (2) *Air power cylinder vent line.* Vent line connects exhaust fitting on brake air power cylinder to vent line elbow on top of engine air cleaner manifold.
- (3) *Fuel tank and transfer vent line.* Vent line extends from top of fuel tank to fitting at frame. From frame fitting, line crosses transfer support cross member to converge with transfer vent line at tee fitting above right side of transfer. Sin-

gle line is used between tee fitting and vent line junction at right side member.

- (4) *Brake master cylinder vent line.* Line from master cylinder extends forward along frame left side member to point below front of cab. Flexible line connects master cylinder vent line to vent line at front of dash panel.
- (5) *Transmission vent line.* Short flexible line connects vent fitting at right side of transmission with junction at large line on frame right side member.
- (6) *Flywheel housing and crankcase vent.* Only opening to atmosphere in engine crankcase is through breather pipe which has common connection with oil filler pipe. For normal operation, crankcase breather (on top of breather pipe) has two openings. One large opening admits air from engine compartment for crankcase ventilation. A second opening in breather is connected by line extending to tee fitting near No. 6 spark plug. Flexible line between tee fitting and vent line on dash panel serves to vent flywheel housing and crankcase breather.

*c. Vent Line and Connection Replacement.* Use lines and fittings of same type and material for replacement. Always install line clips at points where clips were originally provided. Fittings and connections having regular pipe threads should be coated with plastic-type gasket cement when assembling.

*d. Servicing Chassis Unit Breather.* Chassis unit breather (E, fig. 131) is equipped with removable element which must be cleaned periodically.

- (1) Remove cleaner assembly from vent line.
- (2) Remove element from cleaner and wash all parts thoroughly in dry-cleaning solvent or volatile mineral spirits to remove all dirt.
- (3) Allow cleaning fluid to drain out of element; then dip element in light engine oil and allow excess oil to drain off.
- (4) Assemble cleaner and install on vent line.

## Section IX. EXHAUST SYSTEM

### 137. Description

*a. General.* This section includes description, removal, and installation of exhaust system components for all vehicles (fig. 133). However, removal and installation of parts peculiar to the exhaust heater system on water tank truck M222 are covered in paragraphs 338 through 349.

*b. Exhaust Pipes.* A two-piece exhaust pipe connects engine exhaust manifold to muffler. Front exhaust pipe is flange mounted to

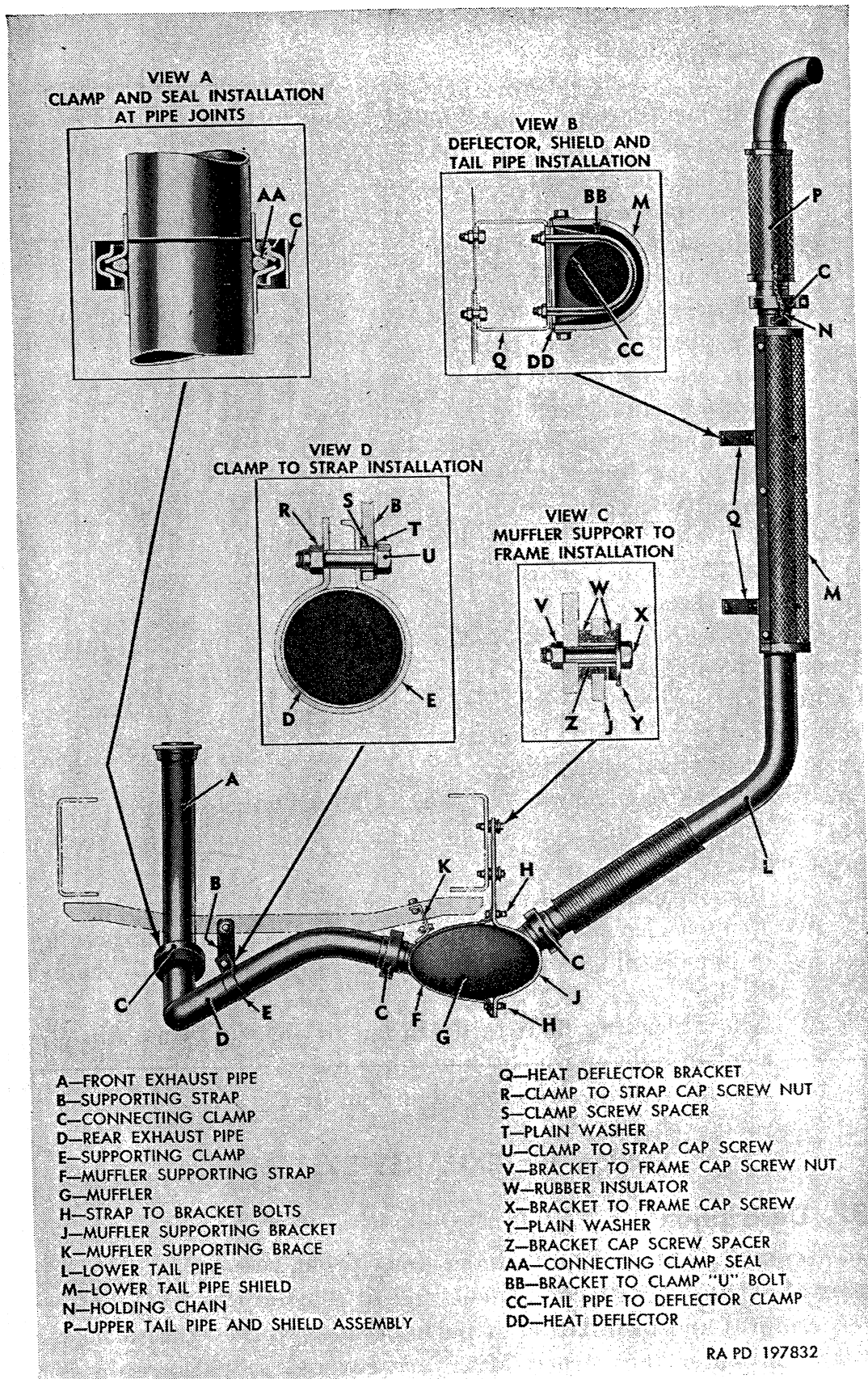

Figure 133. General arrangement of exhaust system—typical of all vehicles, except water tank truck M222.



engine exhaust manifold as shown in figure 134 and secured to rear exhaust pipe with a connecting clamp and seal. A heat shield (H, fig. 134) is clamped to front exhaust pipe and braced to a stud mounted in engine block. Rear exhaust pipe is attached to muffler with a connecting clamp and seal (A, fig. 135) and supported on transmission rear support by a clamp and supporting strap (D and E, fig. 135). On vehicles equipped with a water tank body (M222), a control valve is incorporated in the rear exhaust pipes which allows the exhaust to be diverted to heating chamber in water tank body. For information on servicing exhaust control valve and other components of the water tank heating system, refer to paragraphs 347, 348, and 349.

*c. Muffler* (fig. 135). The muffler assembly is mounted under vehicle at right side and is secured to frame with muffler supporting bracket (J, fig. 133) and muffler supporting strap (F, fig. 133). The muffler supporting strap is also attached to transmission rear support by muffler supporting brace (K, fig. 133).

*d. Tailpipes* (fig. 136). The two-section tailpipe is connected to muffler at lower end with a connecting clamp and seal (view A, fig. 133). The tailpipe assembly extends up the right side of cab structure on outside. Upper portion of lower tailpipe is protected with a demountable guard to prevent injury to personnel, and is mounted to cab structure with U-bolts and clamps (view B, fig. 133). Upper tailpipe is secured to lower tailpipe with a connecting clamp and seal. Upper pipe is chained to lower pipe, and can be disconnected and lowered to obtain lower operable cab height. Late model vehicles have a guard welded to upper tailpipe, and upper end of pipe is curved to prevent rain and snow from settling directly into tailpipe, and to deflect exhaust gases away from cab. Early model straight upper tailpipes may be reshaped to form a curvature at outlet end of pipe as outlined in paragraph 140*c*.

### 138. Exhaust Pipes

*a. General.* The exhaust pipe, connecting exhaust manifold to muffler, is a two-section unit consisting of a front exhaust pipe and a rear exhaust pipe connected together with a connecting clamp and seal.

#### *b. Front Exhaust Pipe Removal.*

*Note.* The key letters noted in parentheses are in figure 134, except where otherwise indicated.

- (1) Remove three jamnuts (B), cap screw nuts (C), and cap screws (F) from flange attaching front exhaust pipe (G) to exhaust manifold (A).
- (2) Push flange down on exhaust pipe. Remove flange seal (E) and gasket (D).



- (3) Remove nut (L) and lockwasher from heat shield brace stud; then pull brace (K) off stud. Remove flat washer from stud.
- (4) Remove connecting clamp and seal (A, fig. 135) attaching front exhaust pipe to rear exhaust pipe. Remove front exhaust pipe. Remove heat shield and clamp from front exhaust pipe.

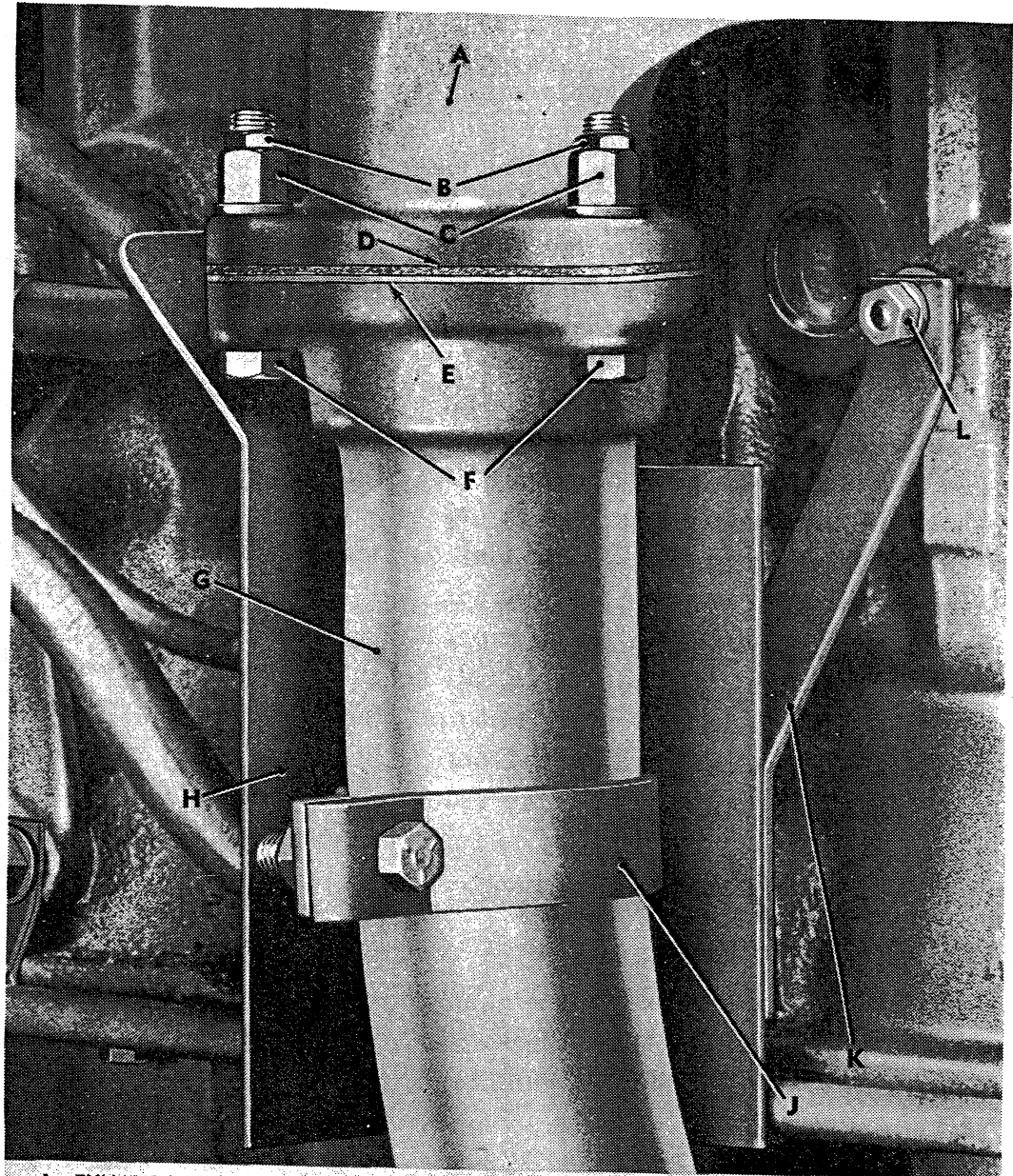

A—EXHAUST MANIFOLD  
 B—JAM NUTS  
 C—FLANGE CAP SCREW NUTS  
 D—FLANGE GASKET  
 E—FLANGE SEAL  
 F—FLANGE CAP SCREWS

G—FRONT EXHAUST PIPE  
 H—HEAT SHIELD  
 J—HEAT SHIELD CLAMP  
 K—HEAT SHIELD BRACE  
 L—BRACE STUD NUT

RA PD 197833

Figure 134. Front exhaust pipe at manifold.

d;  
id.  
ng  
x-  
x-

*c. Front Exhaust Pipe Installation.*

*Note.* The key letters noted in parentheses are in figure 134, except where otherwise indicated.

- (1) Position heat shield (H) on front exhaust pipe (G) with heat shield clamp (J). Install a  $\frac{3}{8}$ -24 x  $1\frac{1}{4}$  cap screw in clamp, and install a  $\frac{3}{8}$ -24 safety nut on cap screw. Do not tighten nut at this time.
- (2) Position flange seal (E) and flange gasket (D) on flange of front exhaust pipe (G). Lift exhaust pipe into position against exhaust manifold; then connect exhaust pipe flange to exhaust manifold with three  $\frac{3}{8}$ -16 x 2 flange cap screws (F) and flange cap screw nuts (C). Tighten nuts evenly. Install and tighten  $\frac{3}{8}$ -16 jamnuts (B).
- (3) Position a  $\frac{3}{8}$ -inch flat washer on heat shield brace stud. Position heat shield brace (K) on stud; then install a  $\frac{3}{8}$ -inch lockwasher and  $\frac{5}{16}$ -24 brace stud nut (L). Tighten heat shield clamp screw nut.
- (4) Attach front exhaust pipe to rear exhaust pipe with connecting clamp and seal (A, fig. 135). Tighten clamp bolt nut sufficiently to prevent leakage.

*d. Rear Exhaust Pipe Removal.*

*Note.* Following procedures apply to all vehicles, except water tank truck M222.

- (1) Remove rear exhaust pipe clamp cap screw nut, cap screw, and washer attaching exhaust pipe supporting clamp (D, fig. 135) to supporting strap at transmission rear support.
- (2) Remove connecting clamps and seals (A, fig. 135) securing rear exhaust pipe to front exhaust pipe and to muffler. Remove rear exhaust pipe. Remove supporting clamp from rear exhaust pipe.

*e. Rear Exhaust Pipe Installation.*

*Note.* Following procedures apply to all vehicles, except water tank truck M222. The key letters noted in parentheses are in figure 135, except where otherwise indicated.

- (1) Position connecting clamps and seals (A) and exhaust pipe supporting clamp (D) on rear exhaust pipe (C).
- (2) Position rear exhaust pipe (C) to muffler (G) and front exhaust pipe (B) and attach with connecting clamps and seals (A). Tighten clamp bolt nuts sufficiently to prevent leakage.
- (3) Aline bolt holes of rear exhaust pipe supporting clamp (D) with hole in exhaust pipe supporting strap (E). As shown in view D, figure 133, place a  $1\frac{3}{32}$ -inch plain washer and

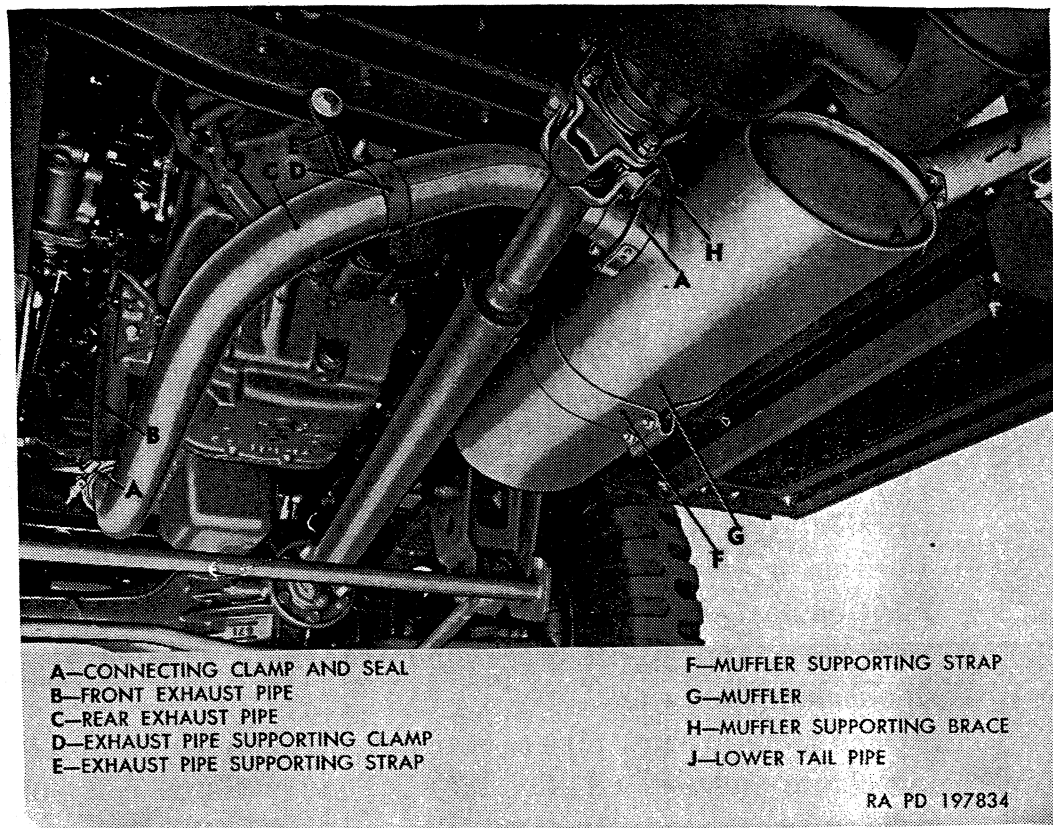

Figure 135. Exhaust pipe and muffler installed.

spacer on a  $\frac{3}{8}$ -24 x  $1\frac{5}{8}$  cap screw; then install cap screw through supporting strap and clamp. Install  $\frac{3}{8}$ -24 safety nut and tighten nut to 20 to 27 pound-feet torque.

### 139. Muffler

*Note.* The key letters noted in parentheses are in figure 135, except where otherwise indicated.

#### a. Removal.

- (1) Loosen cap screw nut on rear exhaust pipe supporting clamp (D).
- (2) Remove connecting clamps and seals (A) attaching rear exhaust pipe (C) and lower tailpipe (J) to muffler. Pull pipes clear of muffler.
- (3) Remove two nuts and cap screws from muffler supporting brace (H), and remove brace.
- (4) Remove two upper and lower nuts and cap screws attaching muffler supporting strap (F) to muffler supporting bracket. Remove muffler assembly.
- (5) Muffler supporting bracket (J, fig. 133) may be removed by removing four nuts and cap screws attaching bracket to frame.

### b. Installation.

- (1) If muffler supporting bracket has been removed, install in sequence shown in view C, figure 133. On each of four  $\frac{5}{16}$ -24 x  $1\frac{5}{8}$  bracket-to-frame cap screws (X, fig. 133), place one plain washer (Y, fig. 133), bracket cap screw spacer (Z, fig. 133), and one rubber insulator (W, fig. 133) over spacer with smaller outside diameter of insulator facing threaded end of screw. Insert cap screw with washer, spacer, and insulator through muffler support bracket. Install another rubber insulator (W, fig. 133) over spacer on cap screw with smaller outside diameter of insulator facing bracket. Position bracket, with cap screws installed, on frame side member. Install four  $\frac{5}{16}$ -24 bracket-to-frame cap screw nuts (V, fig. 133) and tighten to  $9\frac{1}{2}$  to 13 pound-feet torque.
- (2) Position muffler into place in supporting bracket. Install muffler supporting strap (F) around muffler and attach strap to supporting bracket with four  $\frac{3}{8}$ -24 x  $1\frac{1}{4}$  cap screws and  $\frac{3}{8}$ -24 safety nuts. Tighten nuts just enough to support muffler until after exhaust pipe and tailpipe are connected.
- (3) Attach muffler supporting brace (H) to muffler with a  $\frac{5}{16}$ -24 x  $\frac{5}{8}$  cap screw and  $\frac{5}{16}$ -24 safety nut, and attach supporting brace to transmission rear support with a  $\frac{5}{16}$ -24 x  $\frac{3}{4}$  cap screw and  $\frac{5}{16}$ -24 safety nut. Tighten each nut to  $9\frac{1}{2}$  to 13 pound-feet torque.
- (4) Attach rear exhaust pipe (C) and lower tailpipe (J) to muffler with seals and connecting clamps (A). Tighten clamp bolt nuts sufficiently to prevent leakage.
- (5) Tighten rear exhaust pipe supporting clamp cap screw nut to 20 to 27 pound-feet torque. Tighten muffler supporting strap cap screw nuts to 20 to 27 pound-feet torque.

## 140. Tailpipes

### a. Removal.

- (1) The upper and lower tailpipes (fig. 136), together with the heat deflector and shield, can be removed from cab and muffler as an assembly. The assembly can then be disassembled into component parts.
- (2) Remove connecting clamp and seal attaching lower tailpipe to muffler.
- (3) Remove four nuts and cap screws attaching two heat deflector brackets to cab structure. Tailpipe assembly can then be removed.

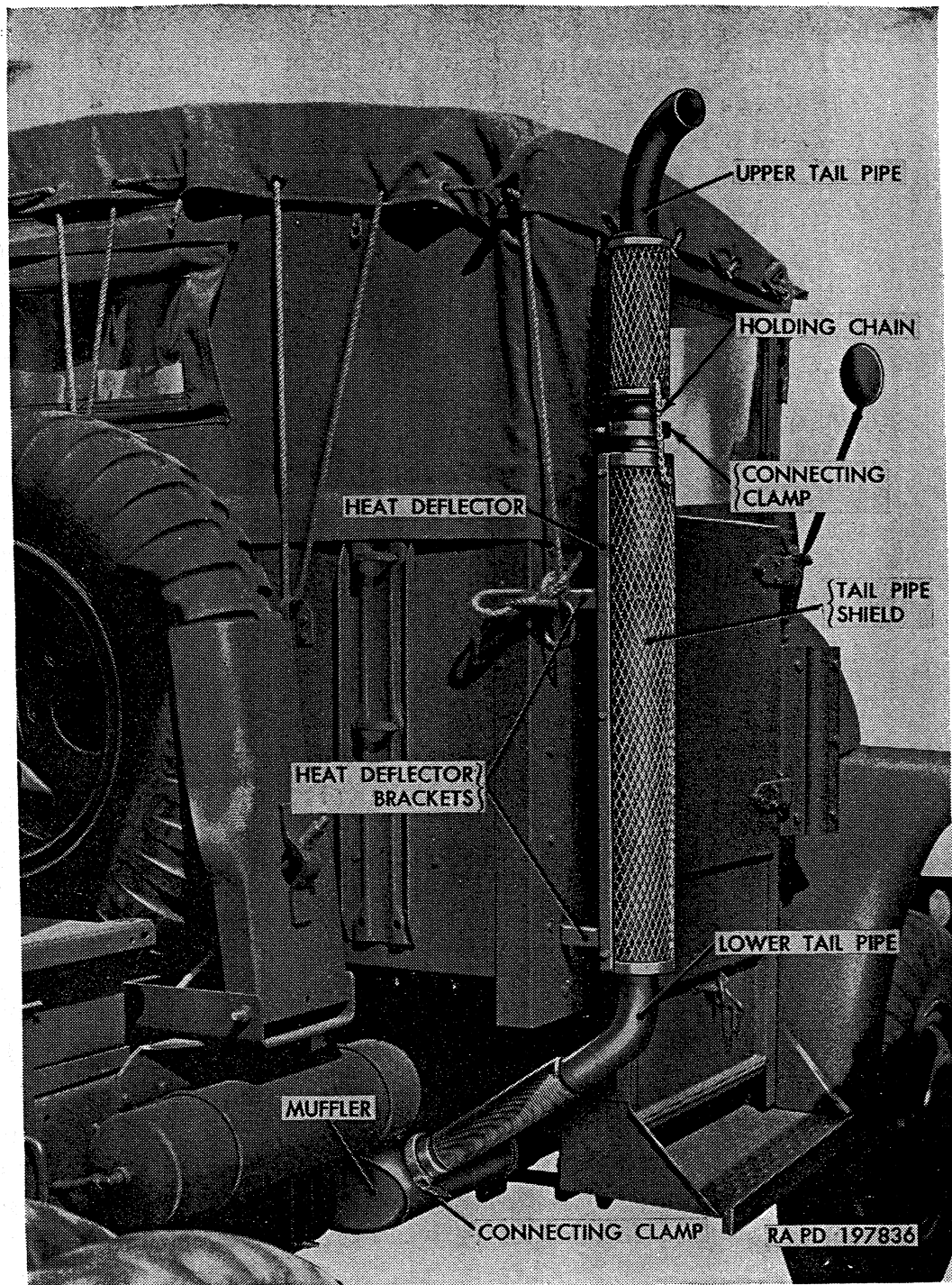

*Figure 136. Tailpipe installed.*

- (4) Spread chain retainer ring and disconnect holding chain from upper tailpipe.
- (5) Remove connecting clamp and seal connecting upper tailpipe to lower tailpipe. Remove upper tailpipe.
- (6) Remove six cap screws and lockwashers attaching lower tailpipe shield to heat deflector. Remove shield.
- (7) Remove four nuts from two U-bolts attaching lower tailpipe (fig. 136) to heat deflector. Remove heat deflector.



*b. Installation.*

- (1) Position two heat deflector bracket clamps on lower tailpipe (fig. 136); then install two U-bolts connecting tailpipe to heat deflector (B, fig. 133). Install four  $\frac{5}{16}$ -24 safety nuts on U-bolts and tighten to  $9\frac{1}{2}$  to 13 pound-feet torque.
- (2) Position lower tailpipe shield on heat deflector; then install six  $\frac{5}{16}$ -18 x  $\frac{3}{4}$  cap screws with  $\frac{5}{16}$ -inch lockwashers. Tighten cap screws.
- (3) Position upper tailpipe on lower tailpipe; then install seal and connecting clamp. Tighten clamp bolt nut sufficiently to prevent leakage.
- (4) Connect holding chain to upper tailpipe retainer ring.
- (5) Connect flexible end of lower tailpipe to muffler with seal and connecting clamp. Tighten clamp bolt nut sufficiently to prevent leakage.
- (6) Position tailpipe assembly on cab structure; then install four  $\frac{5}{16}$ -24 x  $\frac{3}{4}$  cap screws and  $\frac{5}{16}$ -24 safety nuts. Tighten nuts. Make sure that upper tailpipe is positioned on lower tailpipe (fig. 136) so that outlet is away from cab structure.

*c. Reshaping Upper Tailpipe Outlet.* The straight outlet on early model upper tailpipes require reshaping to prevent excessive moisture from entering pipe and settling in crimped section of lower tailpipe, causing excessive rusting and deterioration.

- (1) *Upper tailpipe removal.* Disconnect chain from upper tailpipe; then remove connecting clamp and seal securing upper tailpipe to lower tailpipe (fig. 136). Remove upper tailpipe.
- (2) *Reshaping outlet.*
  - (a) Measure  $3\frac{1}{4}$  inches from top of upper tailpipe and mark this point; measure down from this point an additional  $1\frac{3}{4}$  inches and also mark this point. On diametrically opposite side of the pipe, measure  $4\frac{1}{8}$  inches from the top and mark this point. Using a hacksaw, cut out section from front markings to diametrically opposite marking as shown in A, figure 137. Discard cut out section. File off resulting rough edges.
  - (b) Place cut edge of short section against tailpipe and weld as butt joint (B, fig. 137).
  - (c) Measure  $1\frac{1}{2}$  inches down on center line of short side of short welded section of pipe and mark. Cut off and discard section as shown in B, figure 137.
  - (d) Again measure  $1\frac{1}{2}$  inches down on center line of short length of short section of pipe and mark this point. Cut off section (C, fig. 137) and retain this section. File off resulting rough edges.



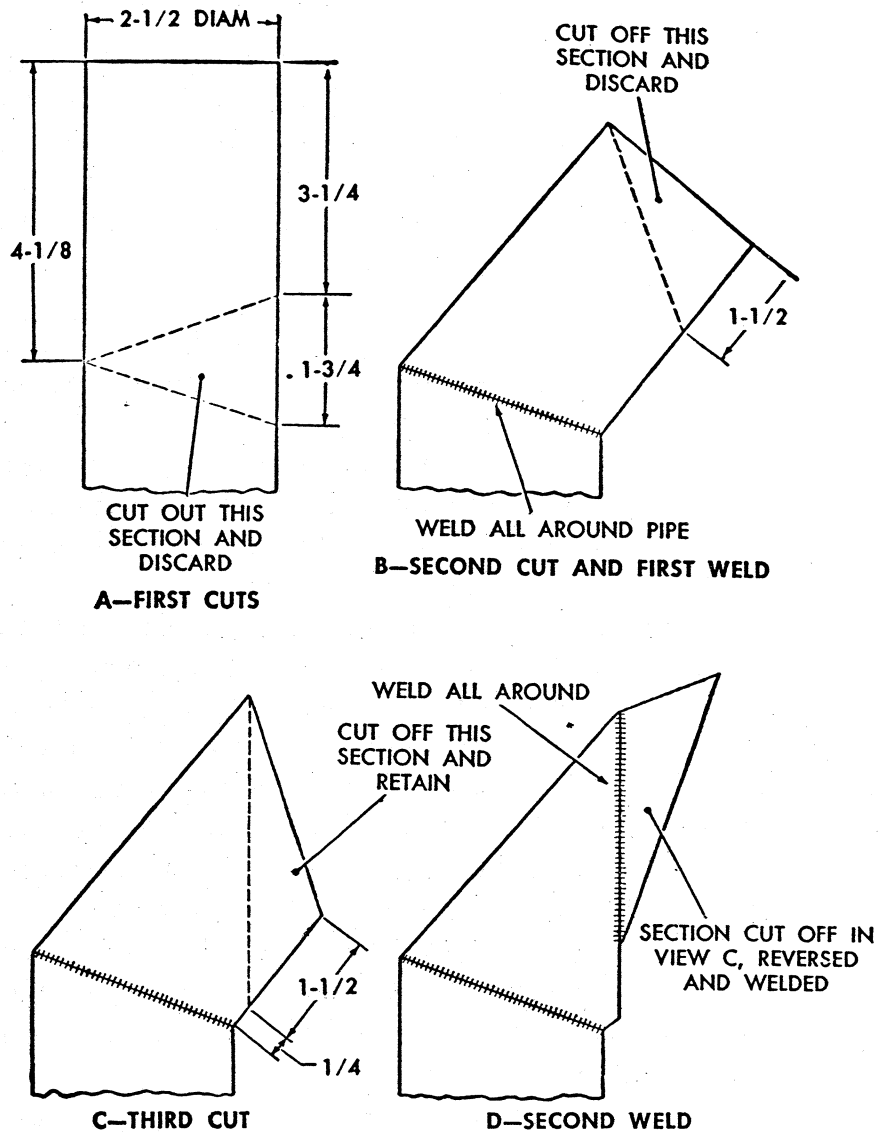

NOTES: 1—ALL DIMENSIONS SHOWN ARE IN INCHES  
 2—ALL WELDS SINGLE V BUTT JOINTS, USE BACK-STEP METHOD TO PREVENT BUCKLING  
 RA PD 197760

Figure 137. Reshaping upper tailpipe outlet.

- (e) Reverse the cut off section as shown in D, figure 137; then weld to top of upper tailpipe opening. This reversed section will provide a hood deflector against rain and snow.
- (3) *Upper tailpipe installation.* To install upper tailpipe, position upper tailpipe on lower tailpipe with hooded end of upper tailpipe away from cab structure. Replace seal and connecting clamp and connect chain to upper tailpipe (fig. 136).

## Section X. COOLING SYSTEM

### 141. Description and Data

*a. Description.* The cooling system is of the sealed pressure-type comprised of water pump, fan, drive belt, radiator, thermostat, pressure valve, and water hose, lines, and fittings connecting radiator, and water pump. These units, when properly maintained, automatically control temperature of cooling liquid. Water pump draws liquid from the bottom of the radiator by action of the water pump impeller and forces it upward through the engine water jackets and passages and through the upper connection to the radiator. Liquid is cooled as it passes downward through tubes of radiator core by action of fan drawing air through radiator. A pressure valve in radiator top tank maintains a pressure of approximately 6½ pounds in the cooling system when the engine is at operating temperature.

*b. Data.*

Cooling system capacity-----	22 qt
Radiator :	
Type-----	fin and tube
Thickness-----	2⅞ in.
Frontal area-----	526 sq-in.
Pressure valve :	
Opening range-----	6¼ to 7½ lb
Thermostat :	
Starts to open-----	160° F.
Fully open-----	175° F.
Fan blades :	
Diameter-----	18½ in.
Number of blades-----	5
Drive-----	Belt in conjunction with water pump and generator
Drive belt :	
Quantity-----	1
Type-----	“V”

### 142. Filling and Draining System

*a. Filling System.* Be sure that drain plug marked WATER on pan at bottom of transmission is installed, and that drain cock at the left rear of cylinder block and at bottom of radiator are closed (fig. 140). Open level cock (fig. 138) at top front of radiator. Remove threaded fillercap from filler neck; then fill system until water is visible in filler neck. Close level cock and continue to add water until no more air bubbles can be seen. Run engine a few minutes to further expel air; then add more water to bring level up to level cock.

**Caution:** Do not pour water into cooling system when engine is above 200° F. Also, cold water poured into the cooling system, regardless of engine temperature, will close the thermostat and will not allow the engine water passages to completely fill. Whenever filling system with cold water, always run engine until normal operating

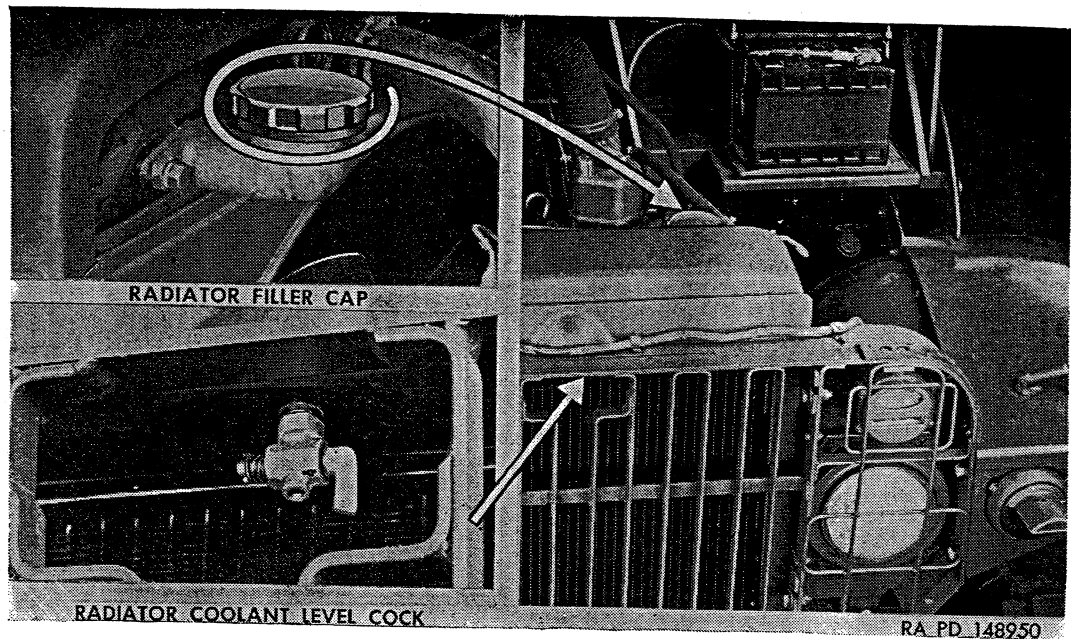

Figure 138. Radiator fillercap and level cock.

temperature is reached (thermostat opens), then add water until level with level cock.

*b. Draining System.* Refer to cooling system draining instruction plate (fig. 139) mounted on instrument board (fig. 29). Run engine at fast idle until normal engine operating temperature is reached (thermostat opens) to stir up any loose rust, scale, etc. Open water level cock (fig. 138) to relieve system pressure. Remove plug at bottom of transmission, marked WATER, also open drain cock at left side of cylinder block and at bottom front of radiator core (fig. 140).

**Caution:** When draining system, inspect drains to be sure none are obstructed. If drain hole is obstructed by foreign matter, clear hole of obstruction, using a soft wire.

### 143. System Tests

*a. General.* Air circulating through the cooling system, as well as exhaust gas leakage into the system, causes rapid corrosion and rust formation which will eventually clog the system and cause overheat-

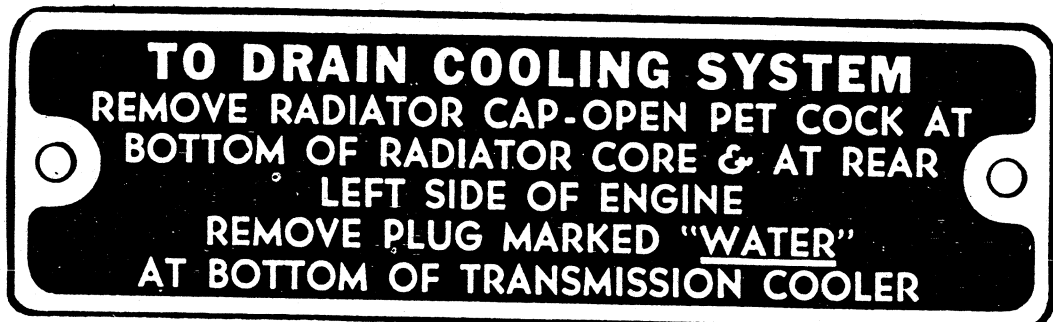

RA PD 148764

Figure 139. Draining instruction plate.

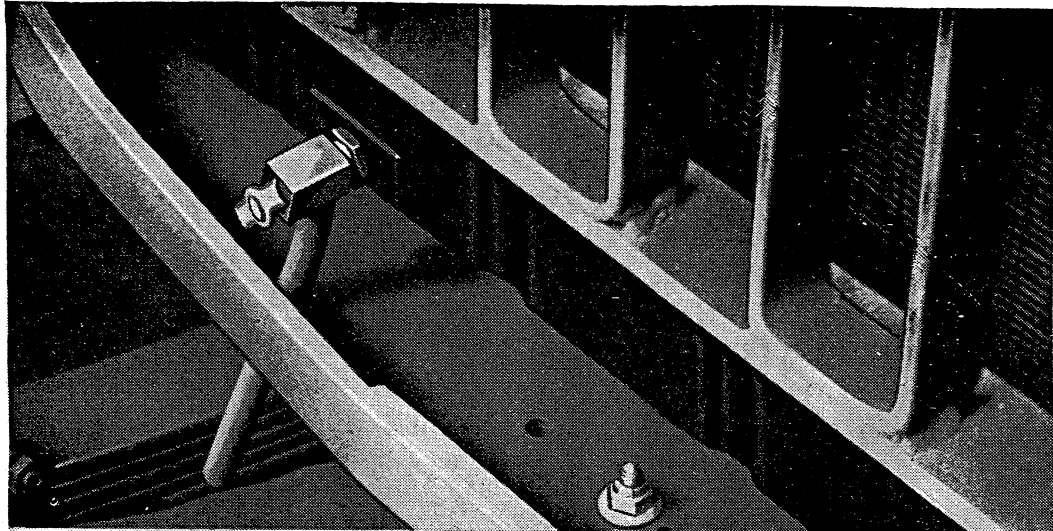

DRAIN COCK AT RADIATOR CORE

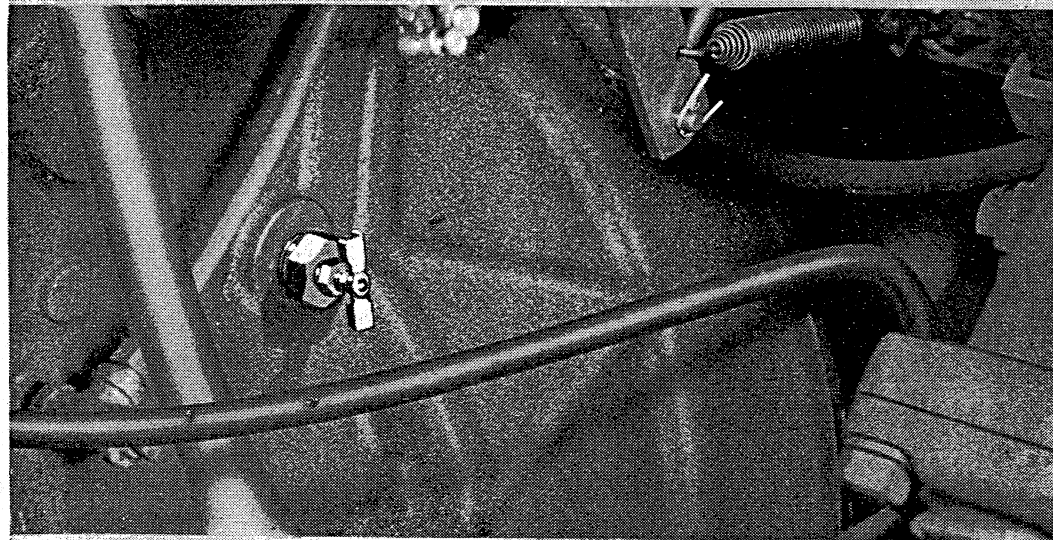

DRAIN COCK AT CYLINDER BLOCK

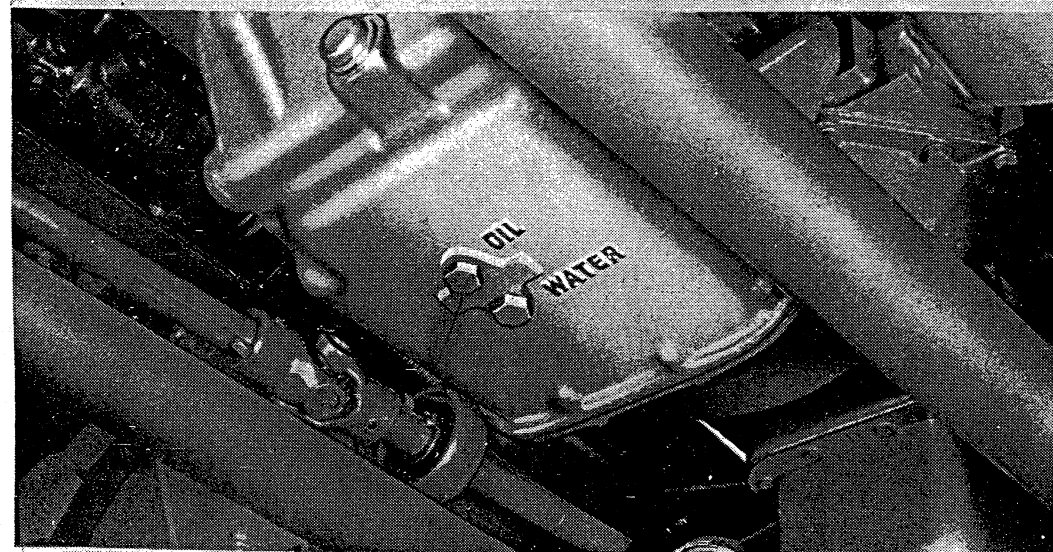

WATER DRAIN PLUG AT TRANSMISSION

RA PD 148905

Figure 140. Cooling system draining points.

ing and loss of cooling liquid. The air may be drawn into the system due to low liquid level in the radiator, leaky water pump, or loose fittings and hose connections. Exhaust gas may be forced into the cooling system past the cylinder head gasket or through cracks in the cylinder head or block.

*b. Air Suction Test.* Adjust level of cooling liquid in radiator, allowing room for expansion so as to avoid any overflow loss during test. Remove pressure valve assembly (par. 146*d*) and temporarily install valve in reverse position. Attach a length of rubber hose to lower end of overflow tube. This connection must be airtight. Run engine, with transmission in neutral, until water temperature gage stops rising and remains stationary. At a steady engine speed, place end of rubber hose in a bottle of water, avoiding kinks and sharp bends that might restrict flow of air. Watch for bubbles in bottle of water. The continuous appearance of bubbles indicates that air is being sucked into the cooling system. Correct condition by tightening cylinder-head bolts (par. 110*c*), water pump mounting cap screws and bolt (par. 148*d*), hose clamps, and fitting connections. Also examine all hose carefully and if cracked, swollen, or deteriorated in any way, replace with a new part.

*c. Exhaust Gas Leakage Test.* Start test with engine cold. Remove drive belt (par. 145*c*) to prevent operation of water pump. Remove thermostat (par. 147*b*). Make sure thermostat lower housing is full of liquid. Refill if necessary. Start engine and accelerate and decelerate it several times. Watch for bubbles in thermostat housing while accelerating engine; also when engine speed drops back to idle. The appearance of bubbles or a sudden rise of cooling liquid indicates exhaust gas leakage into cooling system. Make test quickly before boiling starts as steam bubbles will give misleading results. If exhaust gas leakage is indicated by this test, replace cylinder head gasket (par. 113) and test again. If leaks are still evident, it indicates that cylinder head or block is cracked. Report to ordnance maintenance personnel. Install thermostat (par. 147*d*). Install and adjust drive belt (par. 145*c*). Fill radiator with cooling liquid (par. 142*a*).

## **144. Cleaning and Flushing System**

*a. General.* Water within radiator, cylinder block, cylinder head, and hose must flow freely without restrictions due to rust, scale, etc. Radiator must be cleaned externally to permit unrestricted airflow.

*Note.* A substance which forms on top of coolant at radiator filler neck, having the appearance of engine or transmission oil, is in most instances rust-preventive oil. Rust-preventive oil is not soluble in coolant solution of water and ethylene glycol. Therefore, when vehicle is stationary for a period of time, the rust-preventive oil will accumulate on top of coolant in radiator which is a normal condition.



b. *Cleaning and Flushing System.*

- (1) Drain system (par. 142b). Install water drain plug at bottom of transmission (fig. 140). Also close drain cock at left rear side of cylinder block and at bottom front of radiator (fig. 140).

**Caution:** Be sure temperature of engine is below 200° F. Following directions on container, pour cleaning compound into radiator, then fill system with water. Install radiator fillercap. Start engine and run at a fast idle to heat solution to at least 180° F. Cover radiator if necessary, but do not allow to boil. Continue to run engine for at least 30 minutes. Stop engine and drain system (par. 142b).

- (2) Install drain plug at bottom of transmission; also close drain cocks at left rear side of cylinder block and at bottom front of radiator (fig. 140). Pour the neutralizer (if furnished) into radiator; then fill system with water and install radiator fillercap. Start engine and run it at a fast idle to heat solution to at least 180° F. Continue to run engine for at least 10 minutes. Stop engine and drain system (par. 142b).
- (3) Fill cooling system (par. 142a) with clean water; then install radiator fillercap. Start engine and run at a fast idle to bring water temperature up to at least 180° F. Continue to run engine for at least 5 minutes. Stop engine and drain system (par. 142b). If water is discolored to any extent, repeat the flushing operation.

**Caution:** Do not flush system by inserting a hose in the radiator with the engine running and drain cocks open. This procedure will close the thermostat and stop circulation of the water through the engine.

c. *Rust-Preventives.* Inhibitors or rust-preventives must be used to retard corrosion of metals and prevent formation of scale. Inhibitors are not cleaners and do not remove rust or scale already formed. Treat the cooling system with corrosion inhibitor compound as directed on container, after cleaning, neutralizing, and flushing system.

d. *Cleaning of Radiator.* Clean out dirt, insects, or other accumulated material imbedded in the air passages of the radiator core, using compressed air or a stream of water, but do not use steam.

**Caution:** Do not hold air or water hose too close to the radiator or use excessive pressure, as damage to the radiator may result. Clean any obstructions from overflow hose with a soft wire.

## 145. Fan and Drive Belt

*a. General.* A five-bladed fan, mounted on water pump drive pulley hub, is driven by a V-belt from the crankshaft pulley in connection with water pump and generator.

*b. Fan Belt Adjustment* (fig. 152).

- (1) Loosen adjusting-arm-to-generator cap screw. Loosen nuts on two generator mounting bolts.
- (2) Move generator toward or away from engine as necessary to obtain correct belt tension. The correct tension is when a light pressure on belt midway between generator and water pump pulleys causes  $\frac{1}{2}$ - to  $\frac{3}{4}$ -inch deflection.
- (3) When proper belt tension is obtained, tighten adjusting-arm-to-generator cap screw; tighten two generator mounting bolt nuts.

*c. Fan Belt Replacement.*

(1) *Removal.*

- (a) Remove air compressor drive belt (par. 247b).
- (b) Loosen adjusting-arm-to-generator cap screw. Loosen nuts on two generator mounting bolts (fig. 152).
- (c) Push generator toward engine until belt can be removed from generator, water pump, and crankshaft pulleys; then work belt over fan blades to complete removal.

(2) *Installation.*

- (a) Position belt over blades of fan and onto crankshaft inner pulley. Locate belt on water pump and generator pulleys.
- (b) Adjust belt tension as described in *b* above.
- (c) Install and adjust air compressor drive belt (par. 247).

*d. Fan Blade Assembly Replacement.*

- (1) *Removal.* Remove six cap screws (G, fig. 141) holding fan shroud to radiator. Loosen, but do not remove, four lifting bracket cap screws (J, fig. 141); then move top of shroud away from radiator. Remove four cap screws and lockwashers attaching fan blade assembly to hub; then lift fan blade assembly up between shroud and radiator.
- (2) *Installation.* Position fan blade assembly to fan hub and install four  $\frac{5}{16}$ -18 x 1 cap screws with external-teeth lockwashers. Tighten cap screws evenly. Locate fan shroud with seal against radiator. Install six  $\frac{5}{16}$ -18 x  $\frac{7}{8}$  core and shroud attaching cap screws (G, fig. 141). Tighten all cap screws including four lifting bracket cap screws (J, fig. 141).

## 146. Radiator Assembly

*Note.* The key letters noted in parentheses are in figure 141, except where otherwise indicated.

*a. General.* The radiator assembly is fin- and tube-type with upper and lower tanks. Radiator upper tank incorporates built-in expan-

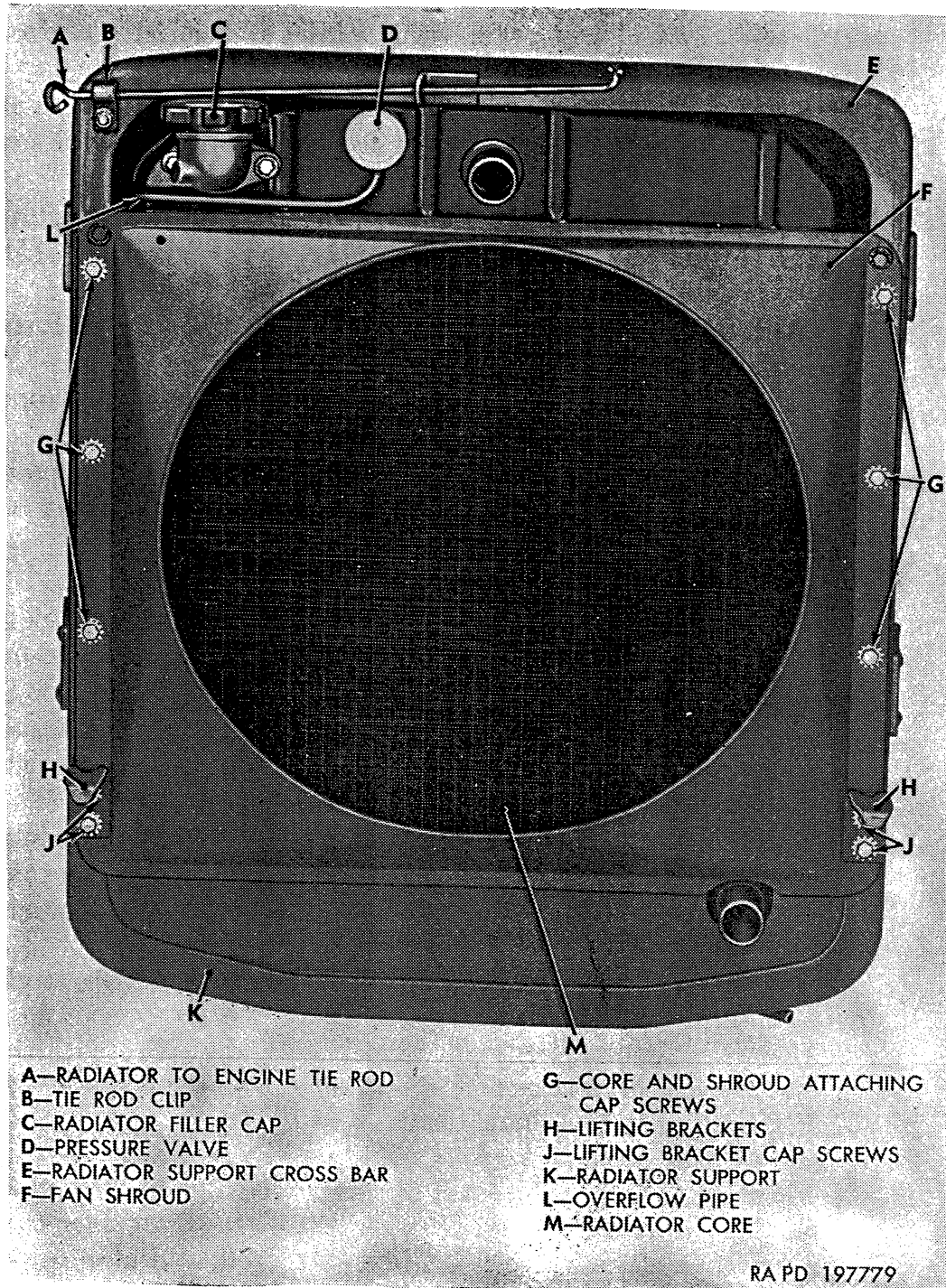

Figure 141. Radiator, support, and fan shroud.

sion tank and replaceable pressure valve. Water level test cock is installed in top tank at front, while filler neck and cap, and inlet connection are at rear of top tank, underneath hood. Radiator core is protected at front side by a brush guard. Fins of radiator core should be cleaned daily with compressed air, if available, after operating on dusty terrain.

*b. Removal.*

- (1) Open drain cock (fig. 140) at bottom of radiator core to drain system.

- (2) Loosen hose clamps; then remove inlet and outlet hose from upper and lower tanks.
- (3) Remove three cap screws and lockwashers at each side attaching upper radiator support crossbar (E) to radiator support (K); then lift off crossbar.
- (4) Remove 10 cap screws (G and J) and lockwashers attaching fan shroud (F), lifting brackets (H), and radiator core (M) to each side of radiator support (K).
- (5) Move shroud toward engine until clear of outlet at lower radiator tank.
- (6) Remove cap screw and lockwasher attaching radiator upper baffle to each radiator side baffle. Remove upper baffle.
- (7) Lift radiator core straight up and out of radiator support (K), using care to guide lower tank outlet fitting past fan blades without damage.

*c. Installation.*

- (1) Lower radiator core into radiator support, using care to guide lower radiator tank outlet fitting past fan blades without damaging radiator core.
- (2) Install upper radiator support crossbar (E) to radiator support (K) at each side with three  $\frac{5}{16}$ -18 x  $\frac{3}{4}$  cap screws with  $\frac{3}{4}$ -inch lockwashers. Tighten cap screws.
- (3) Move shroud with shroud seal into place against radiator support. Install ten  $\frac{5}{16}$ -18 x  $\frac{7}{8}$  cap screws and  $\frac{5}{16}$ -inch internal-external-teeth lockwashers attaching fan shroud (F) and lifting brackets (H) to radiator support (K).
- (4) Install inlet and outlet hose at radiator upper and lower tank; then secure hoses with hose clamps.
- (5) Install radiator upper baffle to radiator side baffles with two  $\frac{5}{16}$ -24 x  $\frac{5}{8}$  cap screws and  $\frac{5}{16}$ -24 nuts. Tighten nuts.
- (6) Fill cooling system (par. 142a).

*d. Pressure Valve Replacement.*

- (1) *Removal.* Open water level test cock (fig. 138) to drain system below pressure valve. Pry out valve retaining ring; then remove pressure valve assembly (D) from radiator upper tank. Remove and discard valve gasket.
- (2) *Installation.* Place new gasket on pressure valve seat. Locate pressure valve assembly in place; then install retaining ring. Be sure retaining ring enters groove all the way around. Fill cooling system (par. 142a) and close water level test cock (fig. 138).

## 147. Thermostat

(fig. 142)

*a. Description.* The thermostat is positive-acting-type, mounted between the thermostat upper and lower housings (D and E). Ther-

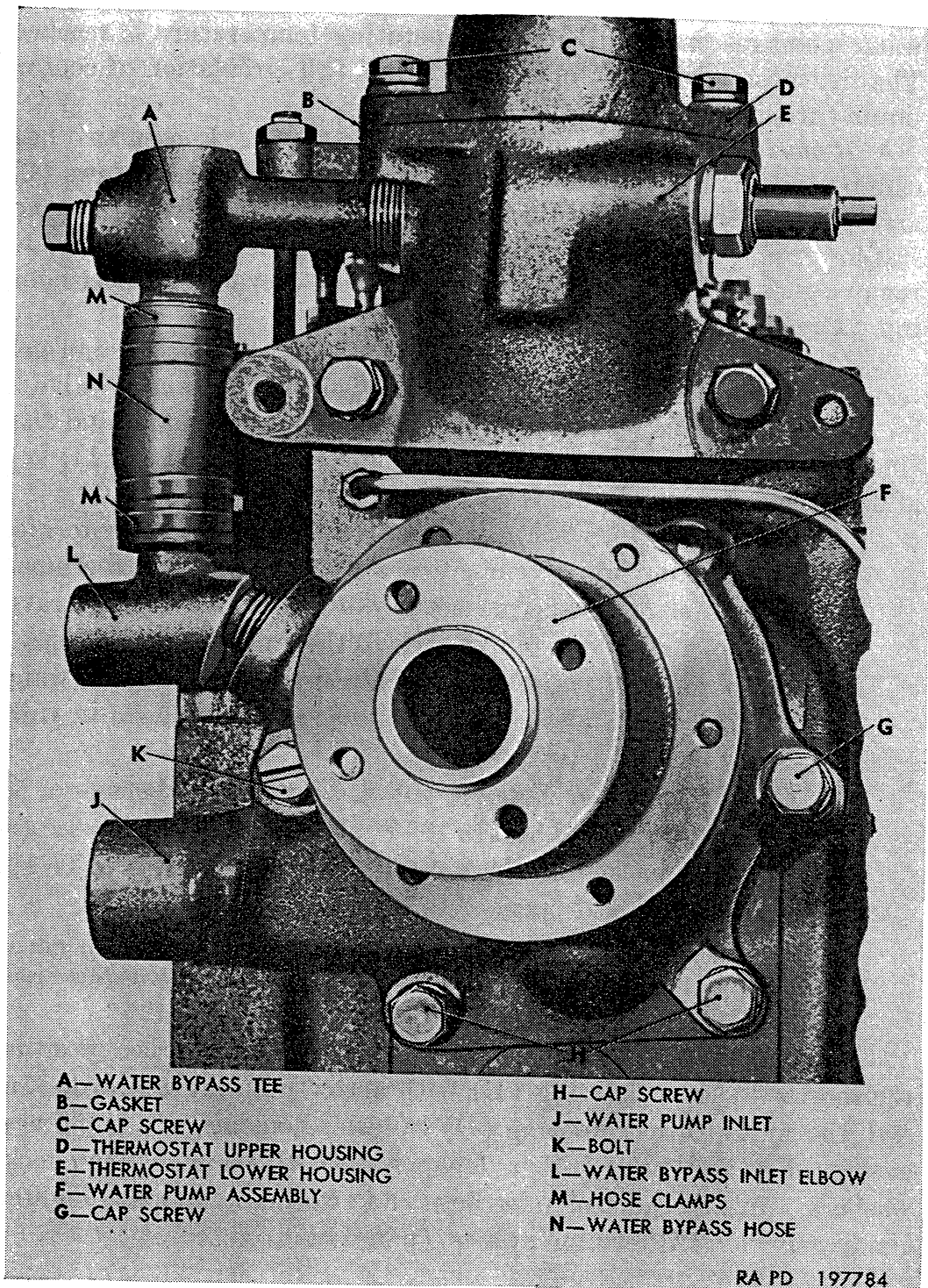

Figure 142. Water pump, thermostat housing, and water bypass fittings.

mostat is a heat-operated restriction valve, and is calibrated to open gradually as engine temperature increases. The valve in the thermostat starts to open at approximately 160° F., and is fully opened at 175° F. When temperature of cooling liquid in the engine is below the calibration of thermostat, the valve in thermostat remains closed, restricting the flow of cooling liquid through radiator. However, a bypass around thermostat permits circulation of liquid through engine



water passages only until normal operating temperature is reached. The thermostat will then open and permit full circulation of cooling liquid through system.

*b. Removal.* Drain cooling system (par. 142*b*). Loosen two hose clamps and remove radiator inlet hose. Remove two cap screws (C) and lockwashers attaching thermostat upper housing (D) to thermostat lower housing (E); then lift upper housing off lower housing and remove gasket (B). Remove thermostat from thermostat lower housing. Discard gasket.

*c. Test.* Remove all accumulated rust, scale, or other foreign material from thermostat assembly. Make visual inspection of valve to be sure bleedhole is open, that valve flange is fully seated, and that the assembly is not bent. Test in the manner described in (1), (2), and (3) below.

- (1) *Check full open temperature.* Heat a pan of water to 175° F., checking water temperature with an accurate thermometer. Submerge thermostat in water. Valve should travel approximately one-fourth inch to the fully open position.
- (2) *Check closing temperature.* Submerge thermostat in water of 150° F. Under this condition, valve should be in fully closed position.
- (3) *Check start-to-open temperature.* Submerge thermostat in a pan of water and heat to 10° F. above the rated temperature which is marked on thermostat valve. Valve should be approximately half-open.

*Note.* Do not attempt to repair thermostat. Units which fail to function properly as indicated by the above tests must be discarded and replaced with new units.

*d. Installation.* Clean thermostat seat in housing; then position thermostat in lower housing (E) with arrow pointing upward. Install thermostat upper housing (D) to lower housing (E), using new gasket (B), and two  $\frac{3}{8}$ -16 x 1 cap screws (C) and  $\frac{3}{8}$ -inch lockwashers. Install radiator inlet hose and two hose clamps. Tighten clamp screws. Fill cooling system (par. 142*a*).

## 148. Water Pump

*Note.* The key letters noted in parentheses are in figure 142, except where otherwise indicated.

*a. Description.* A centrifugal-type water pump is mounted on cylinder block at front end of engine. The water pump is packless-type and leakage around shaft is controlled by a carbon washer and seal assembly. The impeller action of the water pump forces the cooling liquid to circulate through engine water passages, air compressor, transmission cooler, radiator, and connections.

*b. Water Pump Pulley Replacement.*

- (1) *Removal.* Remove fan blades (par. 145*d*). Loosen fan belt (par. 145*b* (1)) until belt can be lifted from pulley. Remove six cap screws and lockwashers attaching pulley (fig. 143) to hub; then remove water pump pulley.
- (2) *Installation.* Position water pump pulley (fig. 143) to fan hub; then install six  $\frac{5}{16}$ -18 x  $\frac{5}{8}$  cap screws and  $\frac{5}{16}$ -inch lockwashers. Tighten cap screws to 12 to 18 pound-feet torque. Locate fan belt in pulley sheave and adjust belt tension (par. 145*b*). Install fan blades (par. 145*d*).

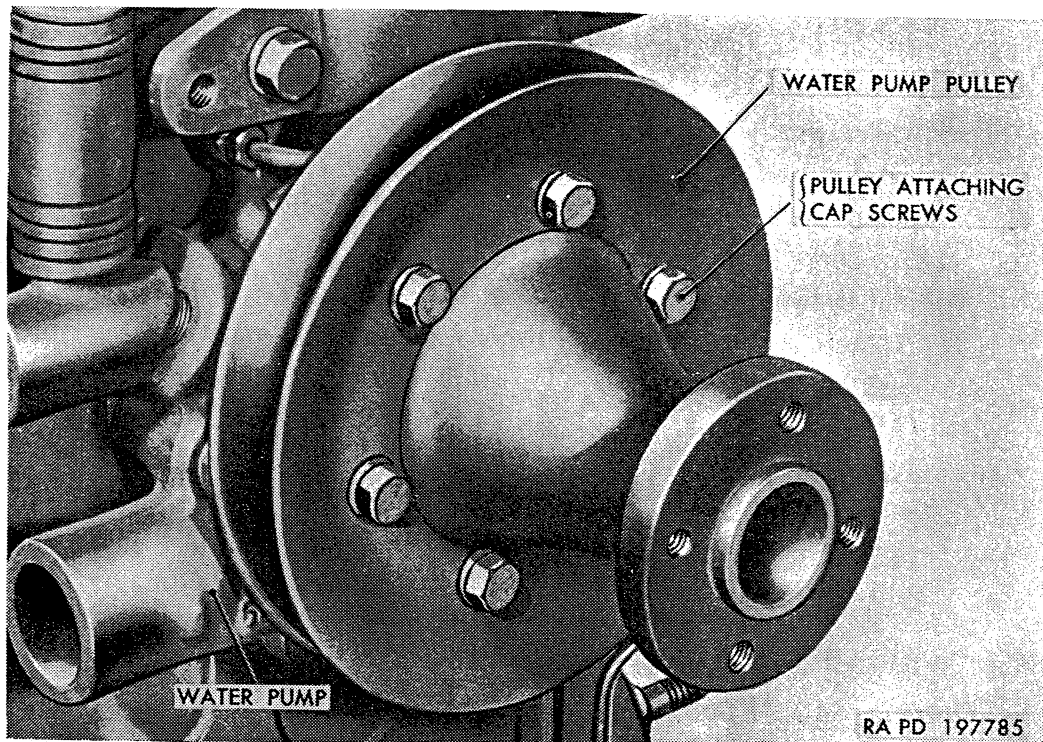

*Figure 143. Water pump pulley installed.*

*c. Water Pump Removal.*

- (1) Drain cooling system (par. 142*b*). Remove pulley (b(1) above).
- (2) Loosen hose clamp attaching radiator outlet hose at water pump; then remove hose from pump inlet (J). Loosen hose clamps (M) connecting water bypass inlet elbow (L) to thermostat housing water bypass tee (A).
- (3) Remove three cap screws (G and H) and one special slotted-head bolt (K) attaching water pump assembly (F) to cylinder block; then remove pump assembly. Remove and discard pump to cylinder block gasket. If pump is to be replaced, remove water bypass inlet elbow (L) from pump.

*d. Water Pump Installation.*

- (1) Coat water bypass inlet elbow (L) threads with joint and thread compound; then install elbow tightly into water pump. Install water bypass hose (N) to inlet elbow (L), but do not tighten hose clamps (M) until pump is installed.
- (2) Using a new water pump to cylinder block gasket, locate pump assembly in position on engine, directing water bypass hose (N) into thermostat housing water bypass tee (A). Place a  $\frac{3}{8}$ -inch lockwasher on  $\frac{3}{8}$ -16 x  $1\frac{7}{8}$  slotted-head bolt (K), and install bolt at right side of water pump. Install one  $\frac{3}{8}$ -16 x  $1\frac{3}{8}$  cap screw (G) with  $\frac{3}{8}$ -inch lockwasher at upper left side of water pump. Install two  $\frac{3}{8}$ -16 x  $1\frac{1}{4}$  cap screws (H) with  $\frac{3}{8}$ -inch lockwashers into lower holes of water pump. Tighten the four cap screws and bolt to 20 to 30 pound-feet torque. Mount pulley on flange at rear of pump hub, using six  $\frac{5}{16}$ -inch lockwashers and  $\frac{5}{16}$ -18 x  $\frac{5}{8}$  cap screws (fig. 143). Tighten cap screws to 12 to 18 pound-feet torque.
- (3) Attach radiator outlet hose to water pump inlet (J); then tighten hose clamps. Tighten water bypass hose clamps (M).
- (4) Install fan belt (par. 145c(2)) and adjust (par. 145b). Install fan blades (par. 145d). Fill cooling system (par. 142a); then start and warm up engine. Inspect hose and water-pump-to-cylinder block gasket for leaks.

## 149. Water Hose, Lines, and Fittings

*a. Description.* Flexible hose, held in place by clamps, are provided at radiator inlet and outlet, water pump inlet, and cylinder head water outlet. Flexible line with fittings is used between cylinder block and air compressor. Transmission cooler water inlet line assembly extends from air compressor to left side of transmission. Transmission water outlet line assembly extends from right side of transmission to engine water pump bypass fitting elbow. Engine cylinder head water bypass line assembly extends from rear of cylinder head to thermostat housing bypass fitting tee.

*b. Maintenance.* Whenever hoses are removed, they must be carefully inspected for evidence of cracks, cuts, or deterioration and replaced with new parts whenever necessary. Always be sure hose clamps are properly located and tightened sufficiently to prevent leaks. Whenever cooling system fittings having pipe threads are being installed, a small quantity of joint and thread compound must be used at threads to prevent leakage, and fittings must be tightened.

## Section XI. STARTING SYSTEM

### 150. Description and Data

*a. General.* Starting system consists of batteries, starter, starter switch, control linkage, and interconnecting cables. The slave battery receptacle and cables, used on early M135 trucks, are a part of the starting system when slave battery is being used to assist in starting engine. Starting system circuit diagrams are shown in figure 144. Starter drive pinion is shifted into mesh with flywheel ring gear teeth and starter switch contacts are closed manually through operation of starter hand control lever and interconnecting linkage. Dash-to-engine ground cable is connected to stud in starter drive end housing.

*b. Starter.* Starter is a four-pole, four-brush unit with three field coils connected in series and one in shunt. The series field windings and insulated brushes are grounded to commutator end head through a capacitor (condenser). Starter is equipped with overrunning clutch-type drive, and is mounted on right side of engine flywheel housing as shown in figure 145. Starter switch is mounted on top of starter field frame; starter switch terminal is connected to field terminal by a strap-type connector. Terminals and connector are coated with waterproofing material after assembly. Commutator end of starter is completely inclosed by a cover installed over end of field frame and held in place by two retaining clips. An O-ring gasket installed between cover and field frame seals out moisture. Sealing of shift lever opening in drive end housing is accomplished by an O-ring packing gasket, shift lever bearing nut, and gasket.

*c. Starter Control Linkage* (fig. 147). Starter hand control lever and shaft is mounted on right side of transmission control tower. Starter control operating lever is attached to end of hand control lever shaft. Operating-lever-to-pickup-lever rod, attached to operating lever, extends down to cross-shaft pickup lever. Cross-shaft, extending across to right side of transmission, has a cross-shaft lever attached to right end. A rod with adjustable yoke connects cross-shaft lever to starter shift lever. Starter linkage can be operated only when transmission control lever is in N (neutral) position. With transmission control lever in any of the driving positions, a cam on selector lever fulcrum acts as a stop for starter control operating lever. This prevents starting engine with transmission control lever in operating position. Arrow on starter hand control level indicates direction (rearward) in which lever must be moved to operate starter. Initial movement of linkage shifts starter pinion into engagement with flywheel ring gear teeth. Additional movement of linkage causes starter shift lever to contact starter switch plunger and close the switch contacts, completing electrical circuit to starter.

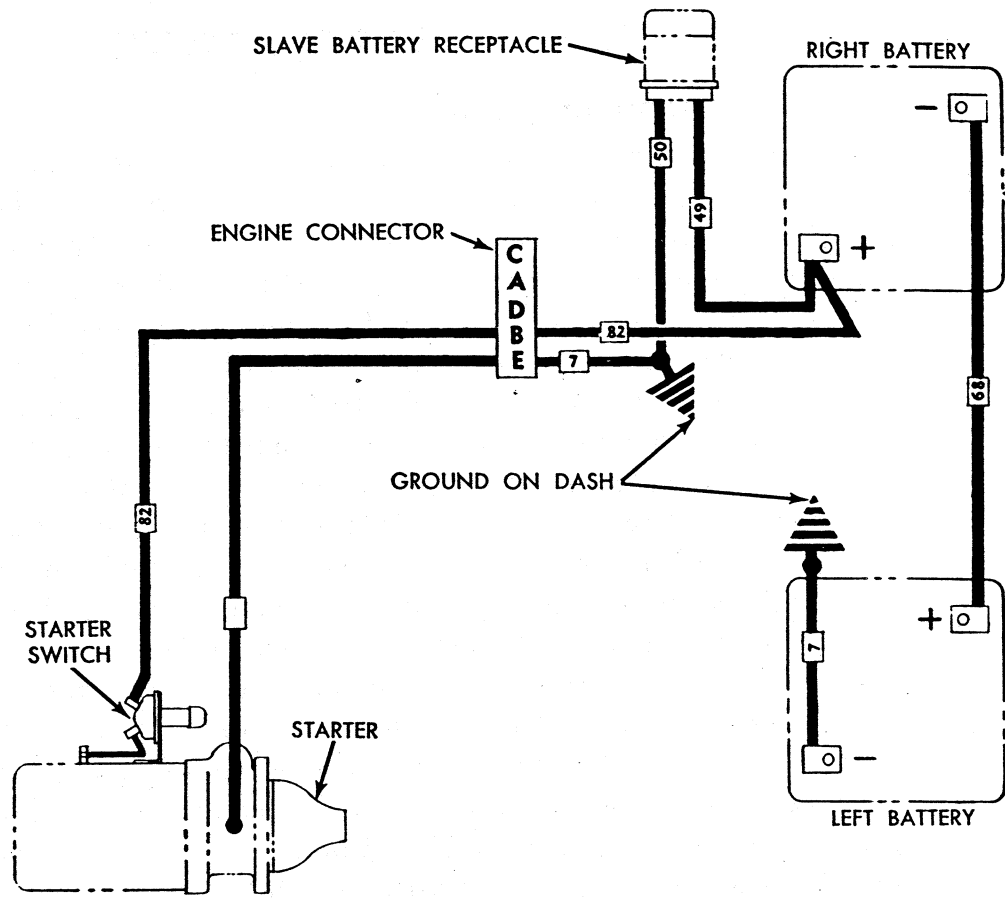

EARLY M135

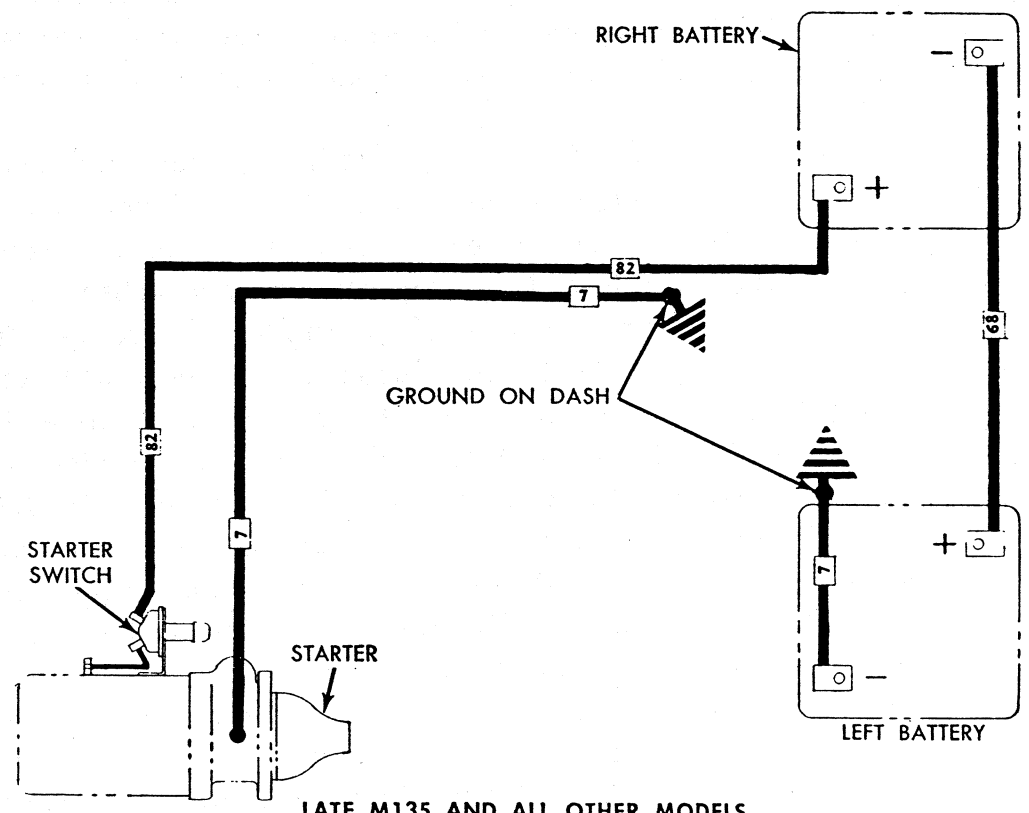

LATE M135 AND ALL OTHER MODELS

RA PD 148761

Figure 144. Starting system circuit diagrams.





- (4) Disconnect starter rod yoke from starter shift lever by removing cotter pin, clevis pin, and two plain washers.
  - (5) Remove nuts from two studs attaching starter to flywheel housing. Move starter forward to remove from flywheel housing. Remove and discard gasket.
- b. Cleaning and Inspection.*
- (1) Wipe all dirt and grease from exterior of starter.
  - (2) Disengage two cover retaining clips from pins in starter field frame. Pull cover off end of starter (fig. 146); then remove O-ring gasket from groove in field frame.

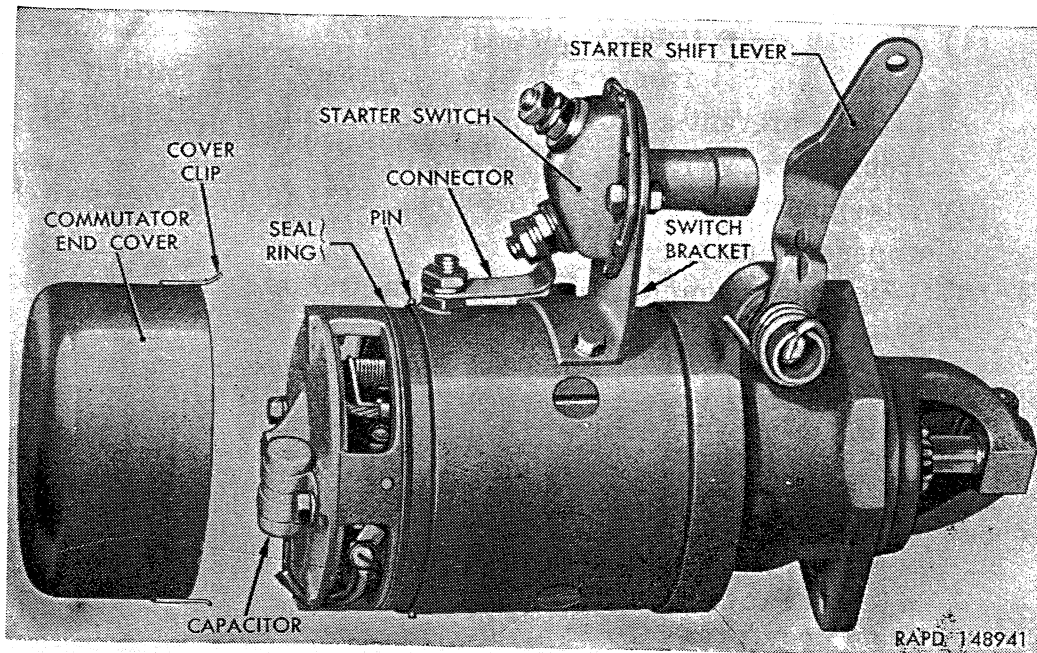

*Figure 146. Starter with end cover removed.*

- (3) Inspect commutator for dirty condition, roughness, high spots, or high mica. If commutator is dirty, clean with grade 2/0 flint paper. Do not use emery cloth for cleaning commutator. Blow out dust with compressed air after cleaning. If commutator is rough, out-of-round, or has high mica, starter must be replaced.
  - (4) Examine brushes for wear. If brushes are worn to length of five-sixteenths of an inch, measured on stamped side, starter must be replaced.
  - (5) Coat O-ring gasket with high temperature ball bearing grease and place in groove in field frame. Install end cover, making sure retaining clips engage pins in field frame.
- c. Installation.*
- (1) Place new gasket over starter mounting studs (fig. 145). Position starter on flywheel housing with holes in drive end

- housing over starter mounting studs. Install a  $\frac{1}{2}$ -20 safety nut on each stud and tighten to 48 to 64 pound-feet torque.
- (2) Connect ground cable No. 7 to stud on starter drive and housing. Connect starter cable No. 82 (fig. 145) to starter switch terminal. Tighten terminal nuts; then coat both cable ends and terminals with waterproofing material.
  - (3) Connect starter cable No. 82 to positive (+) post of right battery (fig. 144).
  - (4) Connect starter rod adjustable yoke to starter shift lever; use a plain washer on each side of shift lever and secure with clevis pin and cotter pin.
  - (5) Check starter linkage adjustment and correct if necessary (par. 152a). Install right front fender (par. 304c).
- d. *Starter Switch Replacement.*

- (1) *Removal.* Remove right front fender (par. 304b). Disconnect starter cable No. 82 from positive (+) post of right battery (fig. 144) to prevent accidental short when cable is disconnected from starter switch. Disconnect starter cable No. 82 from starter upper terminal. Remove nuts securing connector to switch lower terminal and starter field terminal. Remove connector. Remove nuts and lockwashers from two cap screws attaching switch to bracket, remove cap screws, then remove switch (fig. 146) from bracket.
- (2) *Installation.* Position switch (fig. 146) in bracket and secure with two  $\frac{1}{4}$ -20 x  $\frac{5}{8}$  cap screws,  $\frac{1}{4}$ -20 nuts, and  $\frac{1}{4}$ -inch lockwashers. Scrape old waterproofing material off ends of connector. Install connector on switch and fields terminals and secure with lockwashers and nuts. Connect starter cable No. 82 to switch upper terminal. Coat all terminals, nuts, and connector with waterproofing material. Connect starter cable No. 82 to positive (+) post of right battery (fig. 144). Install right front fender (par. 304c).

## 152. Starter Control Linkage

*Note.* The key letters noted in parentheses are in figure 147, except where otherwise indicated.

### a. *Starter Linkage Adjustment.*

- (1) Starter linkage must be adjusted so that starter shift lever (M) will cause contacts in starter switch (N) to close without bending switch bracket forward when hand control lever (A) is pulled rearward to the limit of its travel. Adjustment is made by lengthening or shortening cross-shaft lever-to-starter-shift-lever rod (J) at the adjustable yoke (L). If rod is too short, full switch contact will not be obtained; if too long, switch bracket will be bent forward.

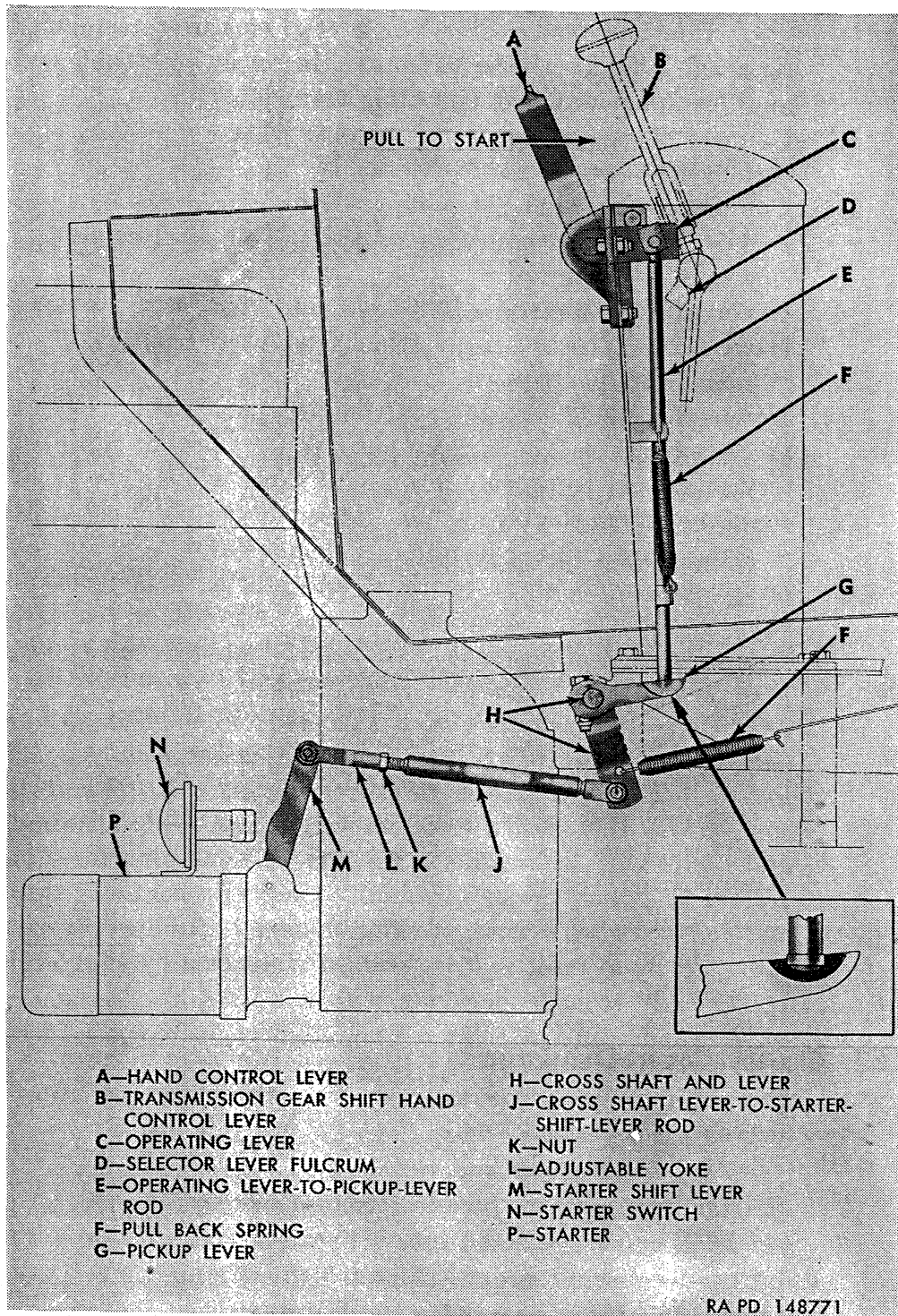

Figure 147. Starter control linkage.

- (2) Remove floor board center section. With rod disconnected from starter shift lever (M) adjust rod length to provide a slight clearance between bottom of operating lever-to-pickup-lever rod (E) and cut in pickup lever (G) when holes in yoke and shift lever are alined. Clearance cannot be seen, but must be determined by feel.
- (3) Connect rod adjustable yoke (L) to starter shift lever (M). While observing action of shift lever, have an assistant pull hand control lever (A) rearward as far as possible. If starter operates and switch bracket is not forced forward, adjustment is satisfactory. If starter does not operate, or if switch bracket is forced forward, lengthen or shorten rod as necessary to obtain condition described in (1) above. Install floor board center section.
- (4) With linkage adjusted, make sure starter hand control lever (A) returns to released (forward) position without binding. If binding is evident, it is caused by the starter control operating lever (C) binding on the selector lever fulcrum (D). Remove shift control tower cover plate. With transmission control lever in neutral and with ignition off, pull starter hand control lever to engaged position and check the clearance between operating lever and selector lever fulcrum (fig. 148). A minimum clearance of one thirty-second of an inch is necessary to prevent binding. File end of operating lever if necessary to obtain this clearance. Lubricate each pivot point in control linkage except cross-shaft bushings; then install control tower cover plate.

*b. Starter Linkage Replacement.*

- (1) *Hand control lever, operating lever, and operating lever-to-pickup-lever rod replacement.* Replacement of these parts requires removal and disassembly of transmission shift control tower. Refer to paragraph 203 for removal, disassembly, assembly, and installation procedures.
- (2) *Cross-shaft and pickup lever removal.*
  - (a) Lift rubber seal off over top of transmission shift control tower. Remove 14 bolt and lockwasher assemblies attaching removable front floor pan to floor. Remove front floor pan.
  - (b) Disconnect cross-shaft lever-to-starter-shift-lever rod (J) from cross-shaft lever.
  - (c) Remove nut and cap screw securing pickup lever (G) on left end of cross-shaft, and remove pickup lever from shaft. Move cross-shaft and lever assembly (H) to right to remove from bracket.



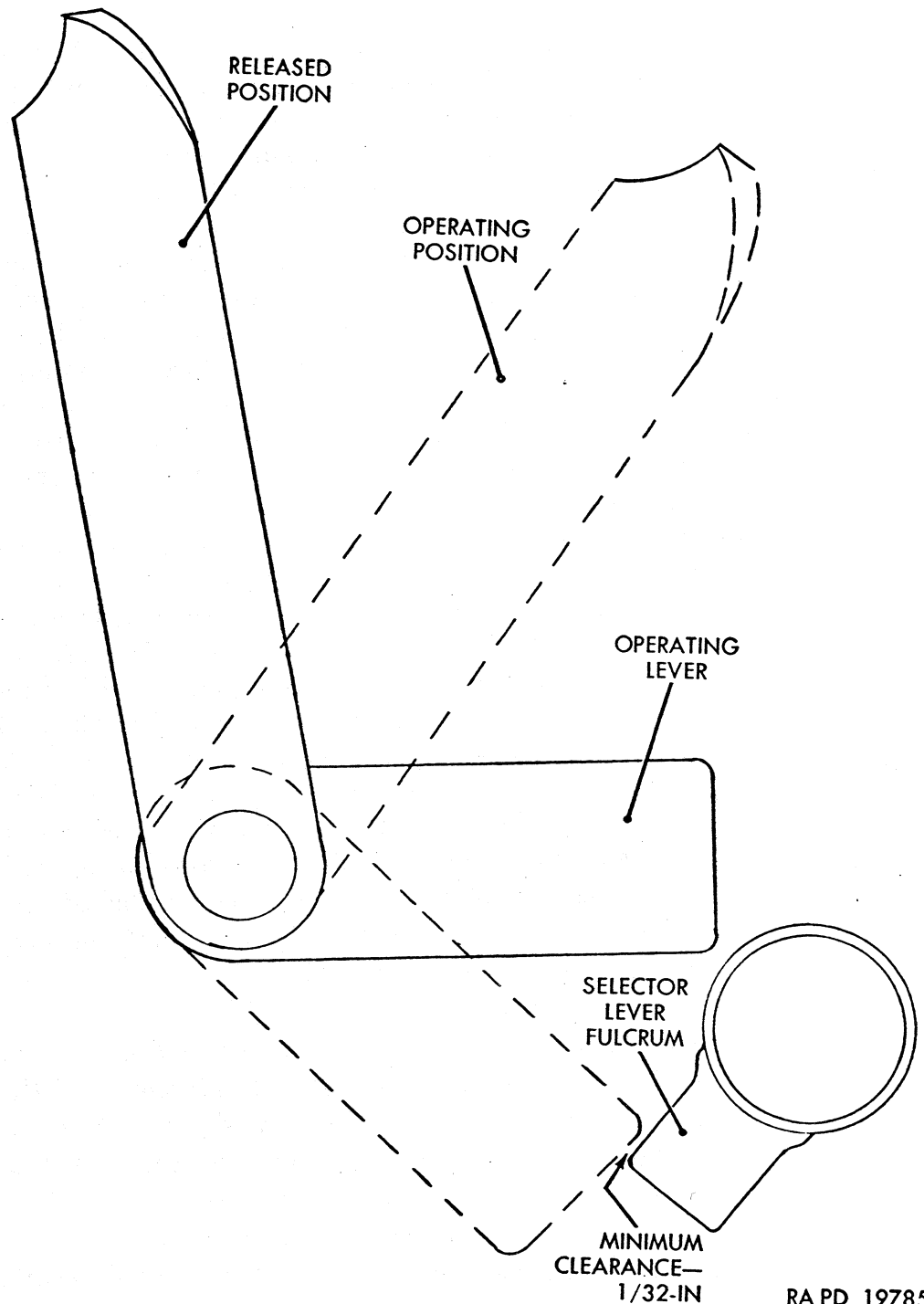

Figure 148. Starter operating lever clearance.

(3) *Cross-shaft and pickup lever installation.*

- (a) Insert cross-shaft through bushings in bracket from right side. Install pickup lever (G) on left end of cross-shaft and secure with a  $\frac{5}{16}$ -24 x  $1\frac{1}{2}$  cap screw and  $\frac{5}{16}$ -24 safety nut.
- (b) Connect cross-shaft lever-to-starter-shift-lever rod (J) to cross-shaft lever, using clevis pin and cotter pin.
- (c) Adjust starter linkage as directed in *a* above.

- (d) Position front floor pan on floor and secure with fourteen  $\frac{5}{16}$ -24 x  $\frac{5}{8}$  bolt and lockwasher assemblies. Place rubber seal over transmission shift control tower and press firmly down against floor pan.

## Section XII. GENERATING SYSTEM

### 153. Description and Data

a. *General.* Generating system consists of the generator, generator-regulator, batteries, and interconnecting cables and wires. Generating system is completely sealed for submerged operation. One capacitor (condenser) is used in generator and two in generator-regulator for suppression of radio interference noise. Generating system wiring circuits are shown in figure 149.

b. *Generator* (fig. 152). Generator used on early M135 trucks is a four-brush, four-pole, shunt-type unit. Generator used on late M135 trucks and all other models is a two-brush, four-pole shunt-type unit. The two-brush-type is used for service replacement on all models. Generator is mounted on right front side of engine and is driven by a belt, in conjunction with the engine water pump and fan, from the engine crankshaft pulley. Inspection plug in generator field coil frame provides a means of inspecting commutator. Generator mounting permits positioning generator to provide proper drive belt tension. All external wiring connections are made through a three-prong plug and receptacle-type connector.

c. *Generator-Regulator* (fig. 153). Generator-regulator is mounted on engine side of cowl below battery at right side of engine. Generator-regulator contains an actuating relay, a circuit breaker relay, a current regulator, and a voltage regulator. An overload circuit breaker is incorporated in the current regulator. The actuating relay and circuit breaker relay are designed to work together to close the circuit from the generator to the battery when generator voltage is sufficient to charge the battery, and to open the circuit when generator slows or stops. The current regulator is a current limiting device which prevents generator output from exceeding its specified maximum; the overload circuit breaker is a safety device provided to open the circuit in the event the circuit breaker relay fails to open. The voltage regulator is a voltage limiting device which prevents the system voltage from exceeding a specified maximum, thus protecting the battery from overcharging and protecting other electrical units from damage which would be caused by excessive voltage. Wiring connections at the regulator are made through two plug and receptacle-type connectors.

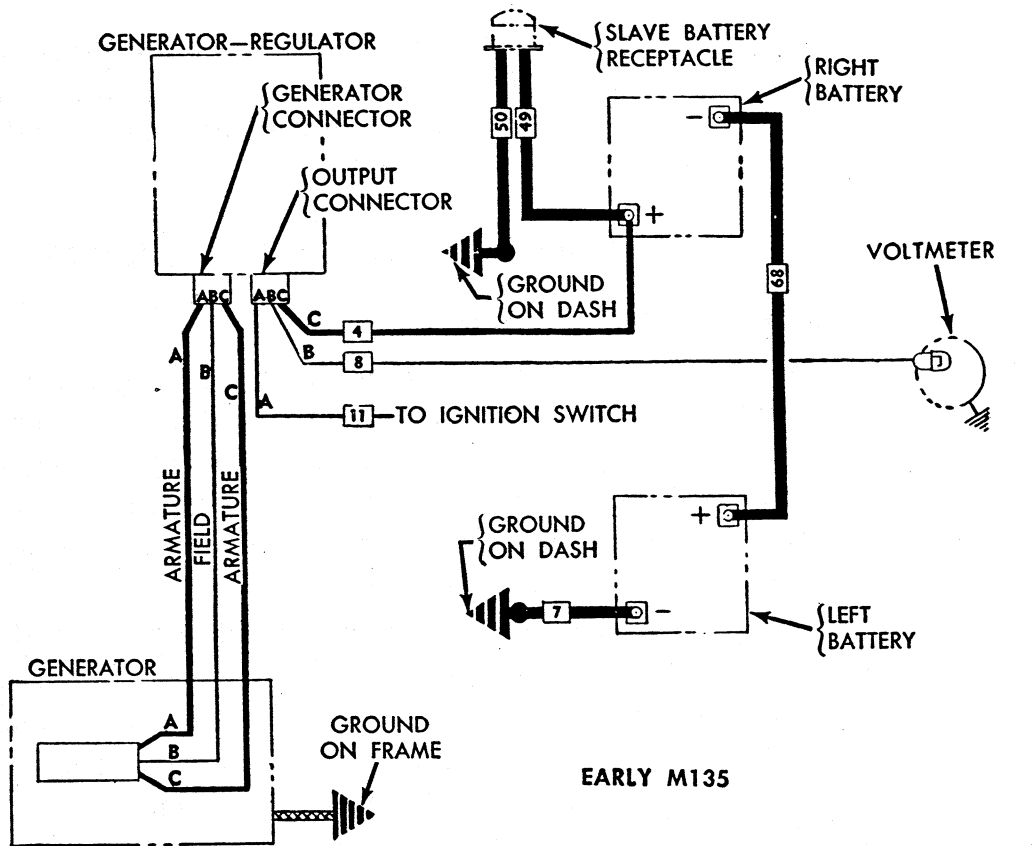

EARLY M135

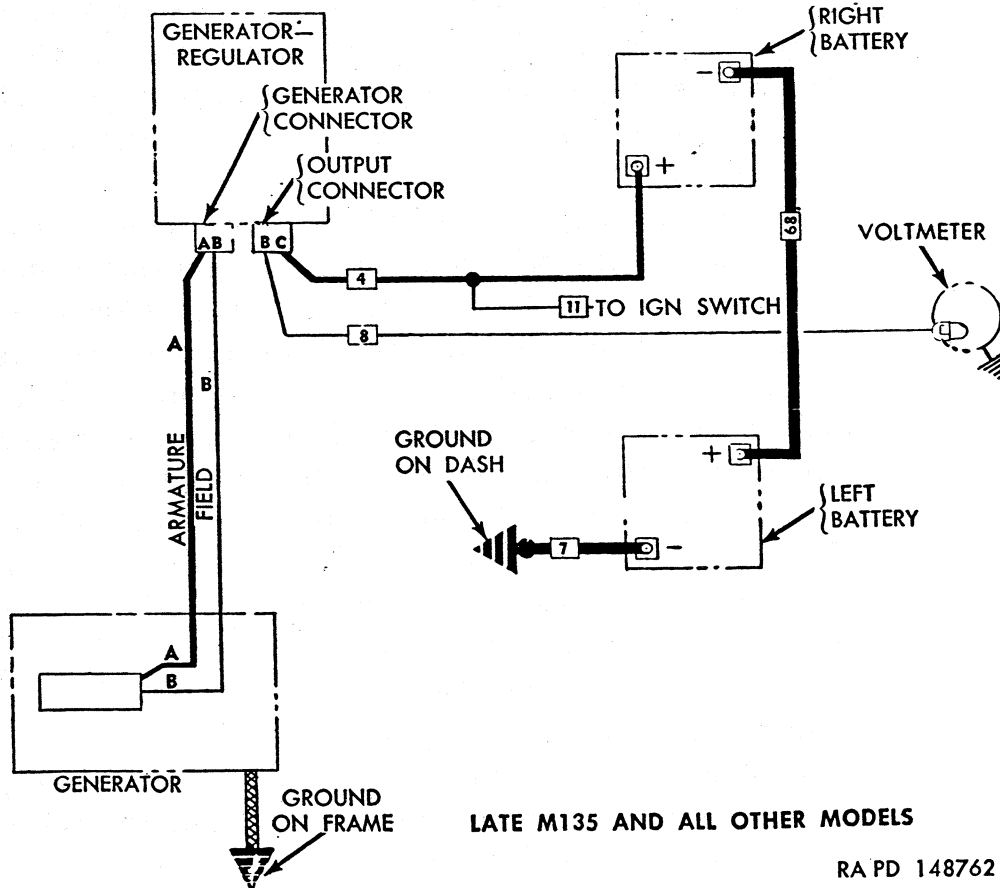

LATE M135 AND ALL OTHER MODELS

RA PD 148762

Figure 119. Generating system wiring circuits.

*d. Data.*

Generator :

Make----- Delco-Remy

Model :

Early M135----- 1117486

Ordnance number----- 7524474

Late M135 and all other models----- 1117495

Ordnance number----- 7355736

Rotation (viewing drive end)----- clockwise

Generator-regulator :

Make----- Delco-Remy

Model----- 1118606

Ordnance number----- 7351952

## 154. Generating System Tests

*a. General.* If the battery-generator indicator in instrument cluster indicates improper charging activity, perform tests outlined below to determine whether the fault is in the generator or generator-regulator before replacing either unit. In analyzing generating system operation, any one of several basic conditions may be found.

*b. Fully Charged Batteries and Low Charging Rate.* This is an indication of normal generator and generator-regulator operation.

*c. Fully Charged Batteries and High Charging Rate.* This indicates that the voltage regulator is not reducing the generator output as it should. A high charging rate to fully charged batteries will damage the batteries, and the high voltage which usually accompanies this condition is very injurious to all electrical units. This operating condition may result from :

- (1) Improper voltage regulator setting.
- (2) Defective voltage regulator.
- (3) Short circuit between charging circuit and field circuit, in either the generator, generator-regulator, or wiring.
- (4) Poor ground connection at regulator.
- (5) High battery temperature which reduces the resistance of the batteries to charge so that they will accept a high charging rate even though the voltage regulator setting is normal. If trouble is not due to high battery temperature, determine the cause of trouble as in (a) through (d) below.
  - (a) Loosen nut on wiring harness connector at generator (fig. 152). Unscrew nut from receptacle; then pull harness plug out of receptacle.
  - (b) Insert male end of test adapter into generator receptacle; then insert harness plug into female end of adapter (fig. 150).
  - (c) Open the field circuit by opening the connector between Nos. 1 and 2 field terminals on adapter (fig. 150).

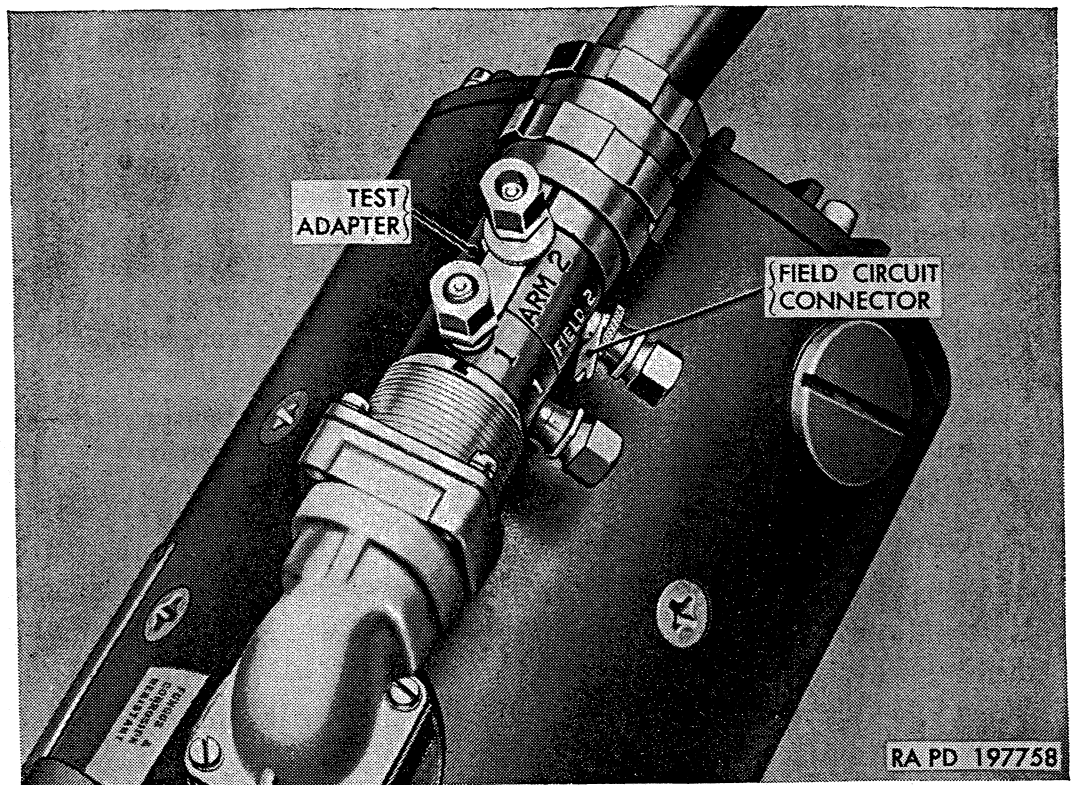

Figure 150. Test adapter installed—field circuit open.

- (d) Start engine and run at medium speed. If output remains high, the generator or wiring harness is at fault. Replace generator-to-regulator harness and repeat test. If output still remains high, replace generator (par. 155). If no output is obtained with field circuit open, replace generator-regulator (par. 156).

*d. Low Batteries and High Charging Rate.* This is an indication of normal generator and generator-regulator operation.

*e. Low Batteries and Low or No Charging Rate.*

- (1) This condition may be due to:
  - (a) Loose connections or frayed or damaged wires.
  - (b) Defective batteries.
  - (c) High circuit resistance.
  - (d) Low voltage regulator setting.
  - (e) Defect within the generator.
- (2) After eliminating causes (a), (b), and (c) above by tightening and cleaning connections, replacing defective batteries, and cleaning all connections to eliminate high circuit resistance, determine whether the generator or generator-regulator is at fault as in (a), (b), and (c) below.
  - (a) Install test adapter at generator receptacle as described in c(5) (a) and (b) above.
  - (b) Start engine and while running at medium speed, momentarily connect field circuit to armature circuit by using a



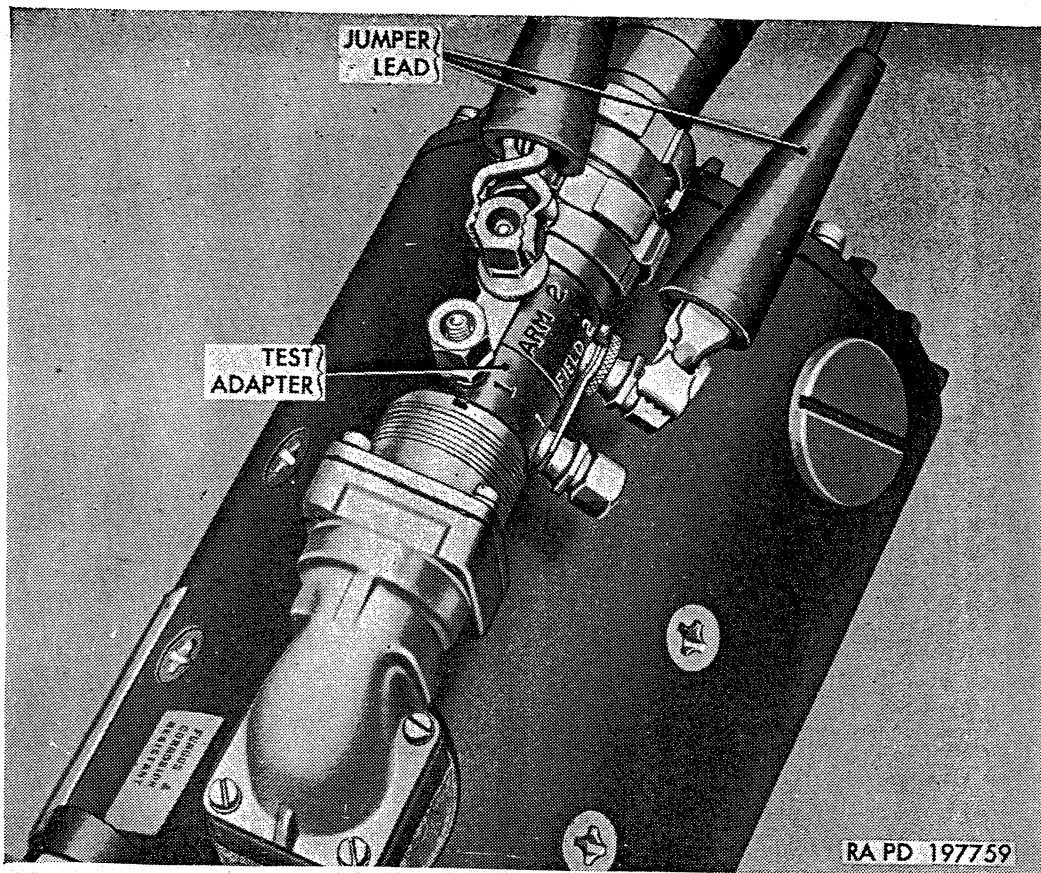

Figure 151. Test adapter installed—field circuit connected to armature circuit.

jumper lead across No. 2 field and No. 2 armature terminals on adapter as shown in figure 151.

- (c) If output does not increase, generator is at fault and must be replaced. If output increases, generator-regulator is at fault and must be replaced (par. 156).

## 155. Generator

(fig. 152)

*a. Generator Inspection.* Remove inspection plug from generator field coil frame. With the aid of a flashlight, inspect commutator for dirty condition, roughness, high mica, or thrown solder. If any of these conditions are evident, replace generator (*b* and *c* below).

*b. Removal.*

- (1) Loosen nut on wiring harness connector at generator. Unscrew nut from receptacle, then pull harness plug out of receptacle.
- (2) Loosen cap screw attaching belt tension adjusting arm to engine thermostat housing. Remove cap screw, lockwasher, and plain washer attaching adjusting arm to generator drive end head. Remove spacing washer from between adjusting arm and generator drive end head. Loosen two bolts at-

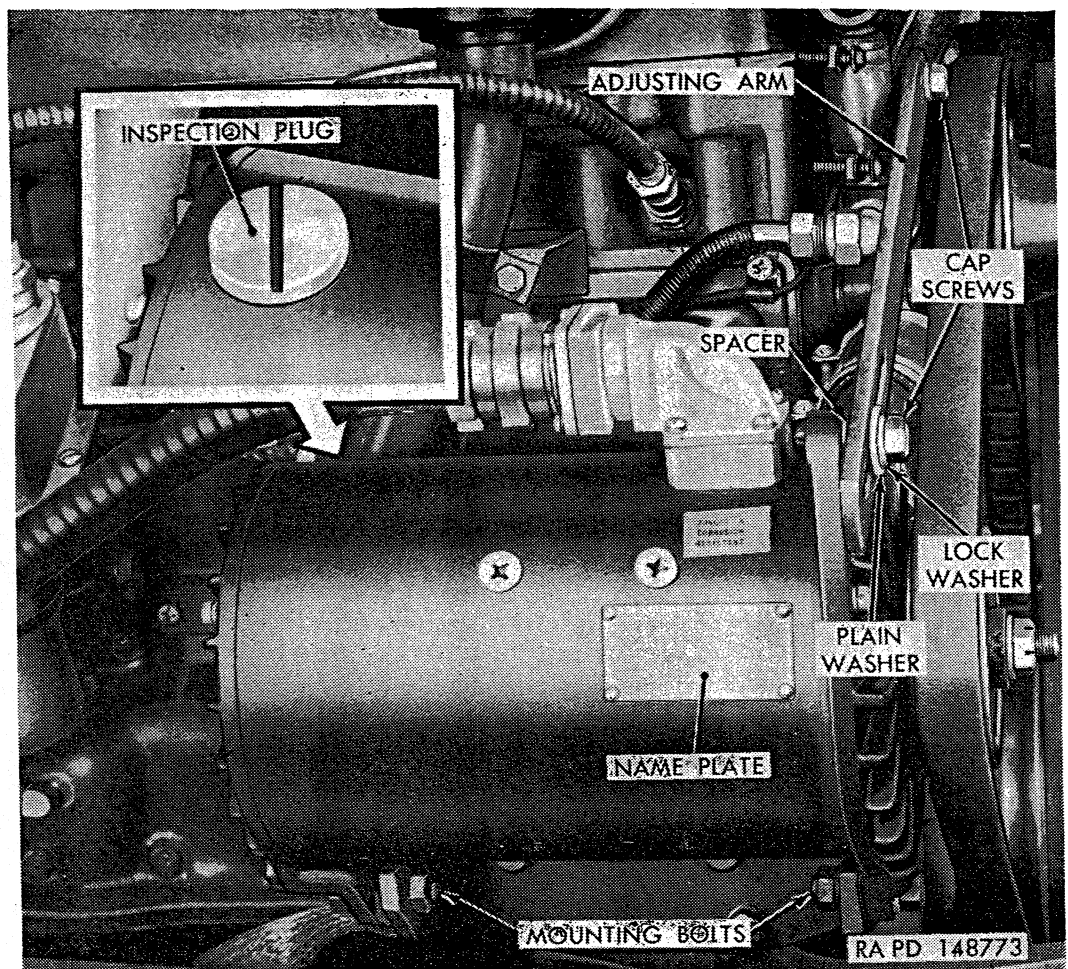

Figure 152. Generator installed.

taching generator drive end head and commutator end head to generator mounting bracket. Swing generator toward engine and remove drive belt from generator pulley.

- (3) Remove two bolts and lockwashers attaching generator end heads to mounting bracket, and remove generator assembly.
- (4) Remove nut and washer securing drive pulley on generator armature shaft. Remove pulley from shaft, using a suitable puller. Remove woodruff key from shaft. Pulley, key, nut, and washer must be installed on replacement unit.

*c. Installation.*

- (1) Install woodruff key in keyway in generator armature shaft; install drive pulley on shaft and secure with plain washer and nut.
- (2) Position generator at mounting bracket and attach with two  $\frac{7}{16}$ -20 x  $1\frac{5}{16}$  bolts and  $\frac{7}{16}$ -inch lockwashers. Bolts thread into nuts which are welded to mounting bracket. Do not tighten bolts.

- (3) Place belt on generator pulley. Position spacing washer between belt tension adjusting arm and generator drive end head; then attach adjusting arm to end head with a  $\frac{3}{8}$ -16 x 1 cap screw,  $\frac{3}{8}$ -inch lockwasher, and  $\frac{7}{16}$ -inch plain washer.
- (4) Polarize generator (*d* below). Insert wiring harness plug into receptacle on generator, making sure locating key and keyway on the two parts are alined. Thread nut onto receptacle and tighten.
- (5) Adjust generator drive belt tension (par. 145*b*). Make sure mounting bolts and adjusting arm cap screws are tightened after adjustment is completed.

*d. Polarizing Generator.* When a new or rebuilt generator or generator-regulator has been installed, generator must be polarized before engine is started. Disconnect wiring harness from connector at generator. Using a jumper wire with suitable prods, momentarily connect field terminal B at generator receptacle to positive (+) terminal on battery. This connection allows a momentary surge of battery current to flow through generator field windings, which automatically gives generator the correct polarity with respect to batteries. Connect wiring harness at generator and tighten connector nut.

## 156. Generator-Regulator

(fig. 153)

*a. General.* Generator-regulator cover is sealed in place and must not be removed by the using organization. If tests described in paragraph 154 indicate faulty generator-regulator operation, the unit must be replaced.

*b. Removal.*

- (1) Disconnect both wiring harnesses at regulator and loosen connector nuts. Pull harness plugs out of receptacles on regulator.
- (2) Remove four cap screws and external-teeth lockwashers attaching regulator brackets to support brackets on cowl, and remove regulator assembly.

*c. Installation.*

- (1) Position regulator assembly at support brackets on cowl and attach with four  $\frac{5}{16}$ -24 x  $\frac{5}{8}$  cap screws and  $\frac{5}{16}$ -inch external-teeth lockwashers.
- (2) Insert wiring harness plugs into receptacles on regulator, making sure locating keys and keyways are alined. Thread connector nuts onto regulator receptacles and tighten. Before starting engine, polarize generator (par. 155*d*).

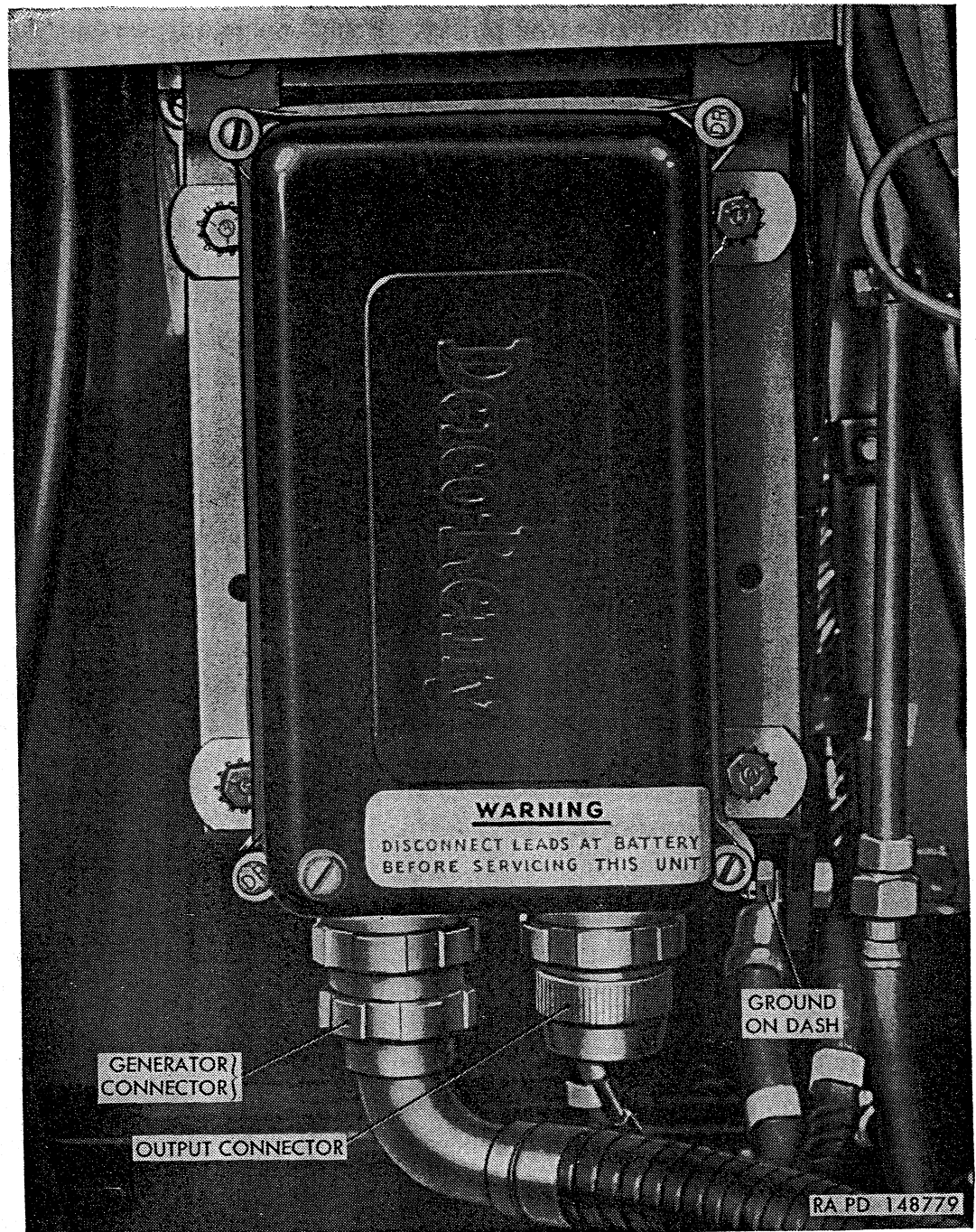

Figure 153. Generator-regulator installed.

## Section XIII. BATTERIES AND LIGHTING SYSTEM

### 157. Description

*a. General.* Battery and lighting system is a 24-volt, submersible-type system. Wiring connections at lights are made through bayonet-type connectors, held together by interlocking shells. Rubber grommets inside of shells protect the connections from moisture. All light circuits are controlled by light switch on instrument panel. Use of lights and operation of light switch are explained in paragraph 45.

Circuit to light switch on early models is protected by a 15-amp automatic reset-type light switch circuit breaker (fig. 176) mounted on steering column brace; on late models, circuit breaker is incorporated in the light switch assembly. To determine whether vehicle is equipped with early or late type circuit, observe markings on face of light switch (figs. 38 and 39). Refer to wiring circuit diagram (fig. 167 or 168) for all light circuits and for each cable identification numeral. Headlights and blackout headlight are equipped with sealed-beam-type lamp units; all other lights are equipped with replaceable bulb-type lamp units.

*b. Batteries* (figs. 154 and 156). Two 12-volt batteries are connected in series to provide 24-volt electrical current for operation of vehicle electrical system. Batteries are submersible-type with special cell vent plugs which prevent entrance of water into battery cells. Batteries are mounted on engine side of cowl, one at each side, and are accessible after raising hood. Negative (-) terminal of left battery is grounded on dash. Positive (+) terminal of left battery is connected to right battery negative (-) terminal by a waterproof cable No. 68. Regulator-to-battery cable No. 4, starter cable No. 82, and slave battery receptacle cable No. 49 (when used) are connected to right battery positive (+) terminal.

*c. Slave Battery Receptacle (Some Vehicles)* (fig. 157). Slave battery receptacle, used on some vehicles, is installed at right side of cab at rear of fender. Receptacle is connected in parallel with the batteries. Receptacle is used to charge the batteries from an external source, or to connect a slave battery to assist in starting engine. Receptacle also provides a convenient source of battery current for operating external electrical accessories.

*d. Service Headlights.* Service headlights are mounted in radiator side baffles on each side of radiator as shown in figure 163, and are protected by headlight brush guard doors which are hinged to radiator brush guard. Headlights are equipped with double-filament sealed-beam lamp units to provide high and low light beams for driving under normal conditions. High and low beams are selected with foot-operated dimmer switch when headlight circuit is energized by the main light switch (par. 45c). Headlights are secured to mounting plates which are attached to radiator side baffles through shockproof mountings consisting of studs with integral rubber insulators. Studs are secured in radiator side baffles by lockwashers and nuts at rear side of baffles. Headlight mounting plates are secured on studs by lockwashers and nuts.

*e. Blackout Headlight.* Blackout headlight is mounted in a support below front end of left fender as shown in figure 163. This light produces a diffused light beam to permit limited illumination when driv-



ing under blackout conditions. Blackout headlight is controlled by main light switch (par. 45b).

*f. Front Marker Lights.* Front marker lights are mounted above each headlight at sides of radiator as shown in figure 163. Each marker light contains three lamps (bulbs) (fig. 165); however, only two lamps in each marker are used on these vehicles. The upper half of each light serves as a service parking light; the lower half, having a special lens which produces a diffused light beam, is used as a blackout marker light. Marker lights are controlled by main light switch (par. 45b).

*g. Stop and Taillights.* One light is mounted at each rear corner of vehicle. Light at right side contains two lamps, and serves as a blackout stop and taillight (fig. 166). Light at left side contains three lamps, and serves as a service stop and taillight and blackout taillight. This light is same as front marker light (fig. 165), except each cable has only one number (Nos. 21, 22, and 24). Circuits to stop and taillights are controlled by main light switch and stoplight switch (par. 45b).

*h. Instrument Panel Lights.* Three lights are used in instrument cluster, two for illuminating face of gages and instruments, and one for indicating when headlight high beam is being used. Instrument lights are controlled by main light switch, and high beam indicator light is controlled by dimmer switch when service headlights are being used (par. 45b).

*i. Trailer Receptacle.* A 12-pin receptacle, installed at rear of vehicle on some models, provides a means of connecting trailer lights to the truck electrical system. On truck tractor M221, an additional trailer receptacle is mounted on frame at rear of cab. Trailer lights are controlled by the main light switch in conjunction with the truck lights. Receptacle cover is held closed by a spring when receptacle is not in use.

## 158. Data

### *a. Battery data.*

Make.....	Delco-Remy
Model.....	6TN23
Ordnance number.....	572524
Voltage.....	12
Quantity.....	2 connected in series
Plates per cell.....	23
Ampere hour capacity at 20 hour rate.....	100
Specific gravity:	
Fully charged (at 80° F.).....	1.275 to 1.290
Recharge at.....	1.225



### b. Lamp-Unit Data.

Service headlight lamp-unit:	
Ordnance number.....	451988
Type.....	sealed-beam
Blackout headlight lamp-unit:	
Ordnance number.....	451989
Type.....	shielded sealed-beam
Candlepower.....	10
Blackout marker and parking light lamp-units:	
Ordnance number.....	190877
Type.....	single-contact G-6 bulb
Candlepower.....	3
Stop and taillights:	
Blackout stop and taillight and service taillight lamp units:	
Ordnance number.....	190877
Type.....	single-contact G-6 bulb
Candlepower.....	3
Service stoplight lamp-unit:	
Ordnance number.....	446914
Type.....	single-contact S-8 bulb
Candlepower.....	3
Instrument panel lamp-units:	
Ordnance number.....	190877
Type.....	single-contact G-6 bulb
Candlepower.....	3

## 159. Batteries

a. *General.* Batteries used with 24-volt electrical systems have an unusually large amount of active material. For this reason, these batteries will produce enough current to operate starter at a much lower electrolyte specific gravity than conventional batteries. While this characteristic may be an advantage under certain conditions, it will create an erroneous sense of security with the battery in a relatively low state of charge. It is not unusual for the batteries to crank the engine satisfactorily when discharged to 1.100 specific gravity at approximately 20° F. However, if the temperature of the electrolyte should suddenly drop a few degrees, the electrolyte is likely to freeze and burst the battery case.

### b. *Care of Batteries.*

- (1) For batteries in use, check specific gravity weekly, especially when ambient temperatures are below +32° F. When batteries are in storage, check specific gravity not less than once a month; charge whenever specific gravity drops below 1.225 (*e* below).
- (2) If vehicle is temporarily out of service for more than 30 days, remove the batteries and store them at the lowest practical temperature which will prevent freezing (+40° F. is recommended).

- (3) For batteries in use or in storage, keep battery tops clean. This is extremely important in order to avoid stray grounds or short circuits.

*c. Testing.*

- (1) *Specific gravity.* Using an accurate reading hydrometer, check specific gravity of electrolyte in each cell of both batteries. A fully charged battery should test between 1.275 and 1.290 at 80° F. Refer to paragraph 371 for extreme hot weather correction, and to paragraph 370 for extreme cold weather maintenance. If specific gravity is less than 1.225, battery should be recharged (*e* below) or replaced with a fully charged battery.
- (2) *Cell voltage.* Due to the sealed construction of submersible-type batteries, cell voltage tests cannot be made.

*d. Filling.* Instructions on top of each battery read: **FILL TO SLOTS IN BOTTOM OF VENT WELLS** (figs. 154 and 156). The battery cell covers are molded with long, circular, tapered vent wells which extend below the inside surface of the cover to the proper electrolyte level. A narrow slot is molded into the side-wall of each vent well. As water is added to the cell, the surface of the rising liquid contacts the slotted lower end of the vent well, causing a distortion of the reflecting surface which is readily discernible. Add pure (preferably distilled) water to each cell as required to bring electrolyte level up to bottom of vent wells. Refer to paragraphs 370 and 371 for battery service instructions under extreme cold or extreme hot weather conditions.

*e. Charging.*

- (1) If the specific gravity of electrolyte in batteries in storage drops below 1.225, charge at a rate of 5 amperes. Do not discontinue charging until the specific gravity is at least 1.270 at 80° F.
- (2) Sometimes batteries will become discharged to a specific gravity approaching 1.000 because of the low ratio of acid to material, because of damage resulting from short circuits, and from extended storage. When this condition exists, it sometimes becomes more difficult to charge these batteries by standard methods than other type batteries. The recommended procedure is to charge these batteries at a rate of 3 to 5 amperes and continue charging until the batteries are fully charged. This may sometimes require as much as 96 hours. If any cell does not accept a satisfactory charge under these conditions, proceed as in (*a*) or (*b*) below.
  - (*a*) Increase the charge rate to approximately 50 amperes for not more than 3 minutes.

- (b) Add approximately 10 milliliters of concentrated sulfuric acid (sp-gr 1.835) to the cell and continue charging at a low rate. This procedure should be tried only in those cases where nothing else will work; it should be done by a thoroughly experienced battery mechanic because the adding of acid to a battery is not normally good practice since it can damage the battery if improperly done. The specific gravity of a cell to which acid has been added must be adjusted to 1.280 specific gravity after battery reaches full charge by removing some of the electrolyte with a hydrometer or syringe and adding water. Charge for an hour to mix the solution, take a hydrometer reading, and if necessary, continue adjustment until the desired readings are obtained.
- (3) If batteries are allowed to remain in an uncharged condition (sp-gr 1.110 or lower), the plates may sulfate. When this condition occurs it may be necessary to keep the battery on charge as long as 144 hours before it is fully charged.
- (4) Charging rate for sulfated batteries will be similar to that indicated in (2) above.
- (5) A constant potential, low voltage charging system is not suitable for reducing sulfation in batteries. A 110 volt, dc charging current regulated to a maximum rate of 5 amperes is recommended for batteries in this condition. Care must be exercised that cells do not gas excessively or reach electrolyte temperatures exceeding 110° F. For charging batteries when in a serviceable condition (not sulfated), the constant potential charger is satisfactory. It is recommended, however, that when battery temperature is below 50° F., the charging circuit be adjusted to obtain 15.4 volts at the battery terminals. For battery temperature above 50° F., a potential of 14.8 to 15.0 volts is sufficient.

*f. Battery Mounting.* On some vehicles, batteries are retained on battery supports by a channel-type retainer which extends across top of battery between cell vent plugs and bears against the battery lifting handles as shown in figure 154. When replacing the original Delco battery with an Exide or Willard battery, it is necessary to relocate the tie down bolts and retainer as shown in figure 155, due to the different arrangement of the cells on these batteries. On other vehicles, battery retainers shown in figure 156 are used; this type retainer permits installation of other make batteries without any modification.

*g. Battery Replacement.* Instructions which follow cover removal and installation of either the right or left battery of both type installations are shown in figures 154 and 156.

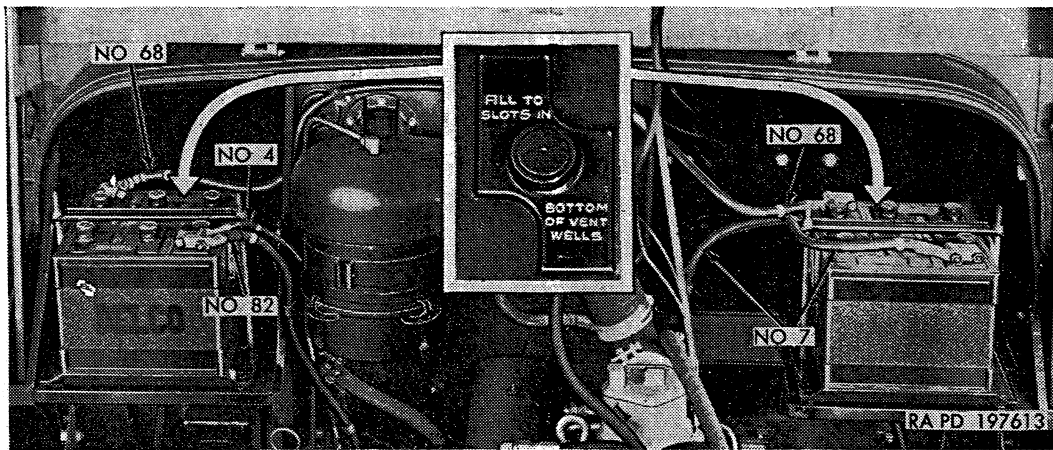
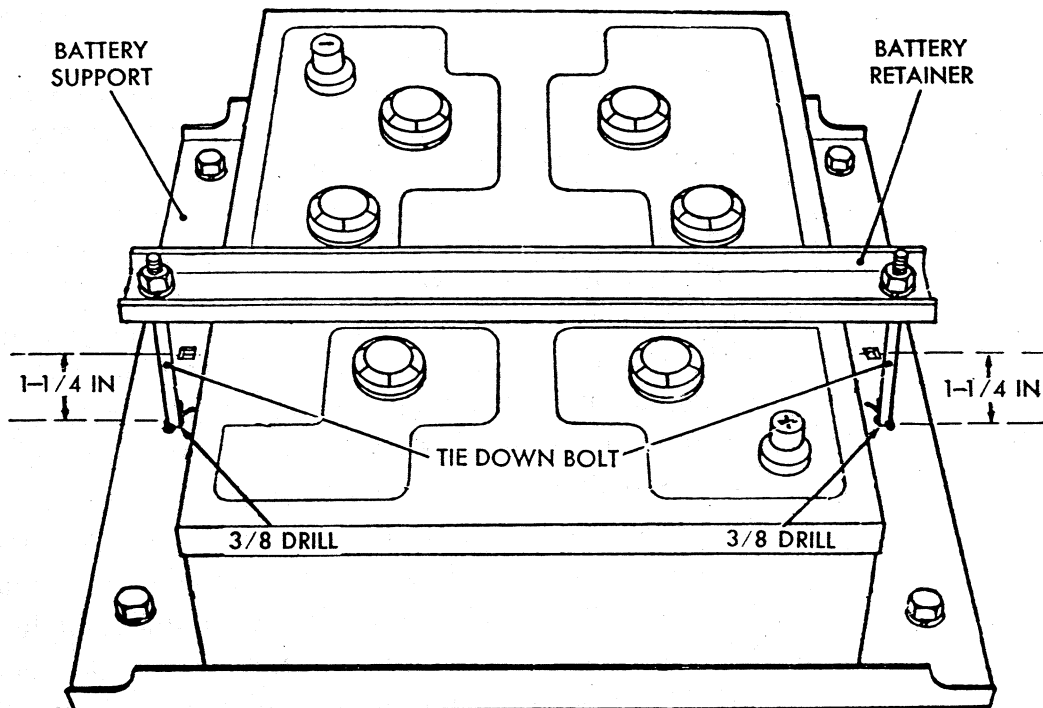

Figure 154. Batteries installed (early type retainer).



RA PD 148781

Figure 155. Relocation of tie down bolts for installation of other make batteries.

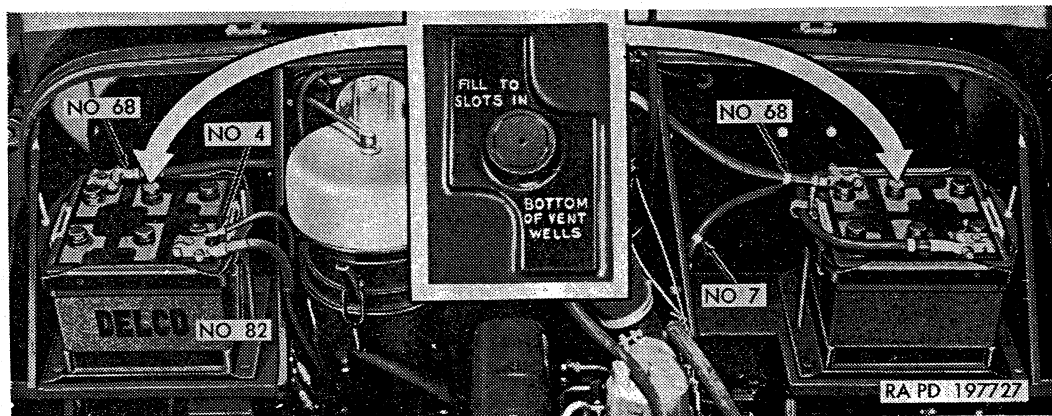

Figure 156. Batteries installed (late type retainer).

(1) *Removal.*

**Caution:** Before starting removal of either battery, disconnect both ends of cable No. 68 connecting the two batteries to prevent accidental short circuit.

- (a) It is not necessary to disconnect cables from clamp-type terminals; loosen clamp bolts attaching terminals to battery posts, spread terminals at split, and lift terminals off battery posts.
- (b) Remove nut and lockwasher from each battery tie down bolt and lift battery retainer off bolts. Lift battery off support.

(2) *Installation.*

- (a) Clean all dirt off battery support and position battery on support. Refer to figure 144 for correct location of battery positive (+) and negative (-) terminals.
- (b) Install battery retainer over tie down bolts. On early type retainer (fig. 154), make sure battery lifting handles are positioned vertically against ends of battery to prevent channel-type retainer from resting on top of battery. Install a  $\frac{5}{16}$ -inch lockwasher and a  $\frac{5}{16}$ -18 nut on each tie down bolt and tighten.
- (c) Clean battery posts and inside of terminals, install terminals on battery posts, and tighten terminal clamp bolts. If cables were disconnected from terminals, refer to figure 154 or 156 for number identification of cables connected to each terminal. If slave battery receptacle (fig. 144) is used, cable No. 49 (not shown in figure 154) also connects to positive (+) terminal of right battery. After tightening terminal clamp bolts, coat terminals with grease to retard corrosion.

## 160. Slave Battery Receptacle and Cables (Used Only on Early M135)

a. *Removal.*

- (1) Remove right fender (par. 304b).
- (2) Disconnect slave receptacle positive (+) cable No. 49 from right battery positive (+) terminal. Disconnect slave receptacle negative (-) cable No. 50 from ground at dash behind generator-regulator.
- (3) Remove nut and bolt attaching two cable clips to floor sill. Remove clip from each cable.
- (4) Remove four nuts and bolts attaching slave battery receptacle (fig. 157) to side of cab. Withdraw receptacle and cable from hole in cab.

*b. Installation.*

- (1) Insert cables through hole in cab and position receptacle against cab. Attach receptacle to cab with four  $\frac{1}{4}$ -28 x  $\frac{7}{8}$  bolts and  $\frac{1}{4}$ -28 safety nuts. Tighten nuts to 5 to 7 pound-feet torque.
- (2) Connect cable No. 49 to right battery positive (+) terminal. Connect cable No. 50 to ground on dash in conjunction with starter ground cable (No. 7).
- (3) Install clip on each cable and attach both clips to floor sill below right battery.
- (4) Install right fender (par. 304c).

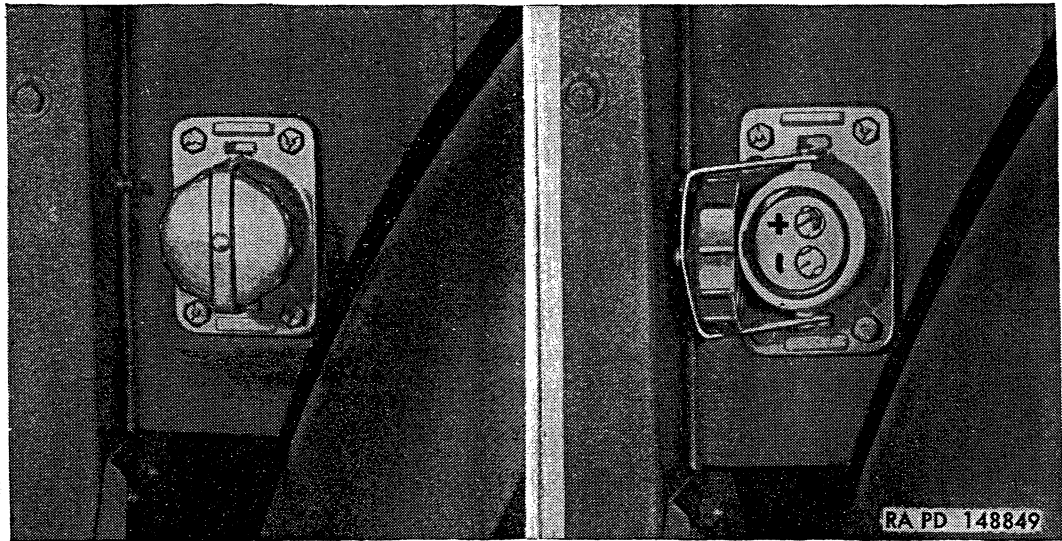

Figure 157. Slave battery receptacle with cover closed and open (used only on early M135).

## 161. Service Headlights

*a. Headlight Beam Adjustment.*

- (1) Headlight beams must be accurately aimed. When aiming headlights, replace sealed-beam lamp unit (*b* below) if beam pattern is distorted. Beam distortion is usually due to a sprung or dented reflector, a condition sometimes caused by careless handling.
- (2) Conventional aiming equipment should be used when aiming headlights; however, headlight beam can be accurately adjusted as in (*a*) through (*f*) below.
  - (a) Position unloaded vehicle on level floor with headlights 25 feet from a smooth vertical surface such as a wall or door, preferably of light color. Centerline of vehicle must form a right angle to the vertical surface (fig. 158).
  - (b) Measure height of headlight center from floor; then draw a horizontal line (X-X) on vertical surface at this height.



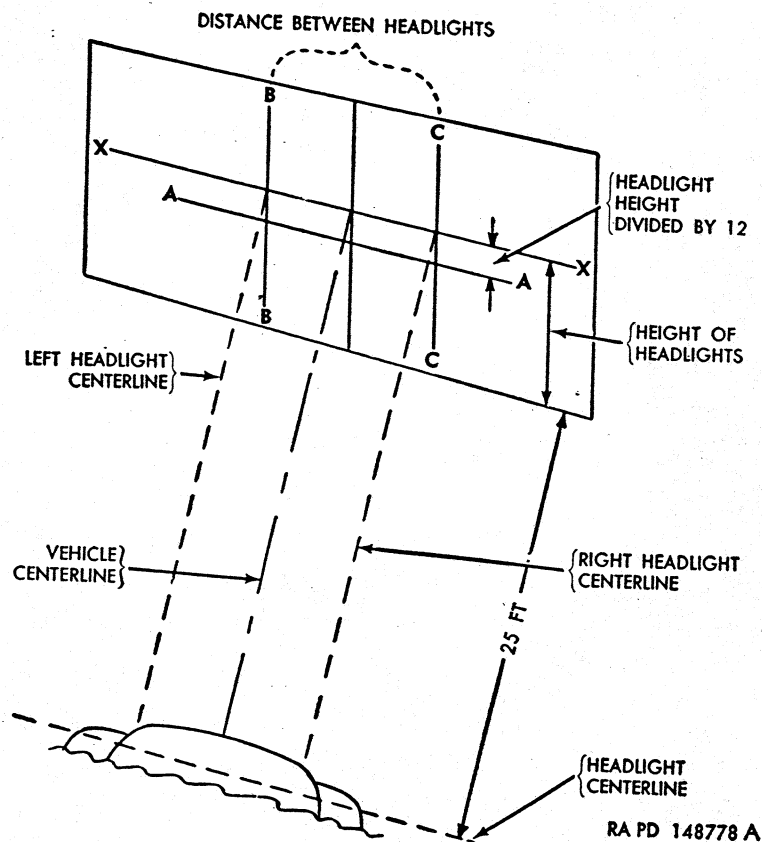

Figure 158. Headlight aiming chart.

- Draw a second line (A-A) parallel with and one-twelfth the height of the headlight center below the first line.
- (c) Locate point at which projected centerline of vehicle intersects these lines. Measure distance between headlight centers; then divide this distance equally on both sides of center mark. Draw a vertical line (B-B and C-C) through each of these points (fig. 158).
  - (d) Unlatch headlight brush guard door at top and swing door down. Remove three screws attaching headlight door (rim) to headlight body, and remove door. Turn headlights on (par. 45) and select high beam with dimmer switch.
  - (e) Cover one headlight while adjusting the other. Aim light beam with two adjusting screws (fig. 159). Top screw provides vertical adjustment and side screw provides horizontal adjustment. Turn adjusting screws as necessary to obtain a beam pattern as near as possible to that shown in figure 160.
  - (f) Install headlight door (rim) and attach to headlight body with three screws. Close headlight brush guard door. Cover headlight on which adjustment is completed while adjusting the other headlight.

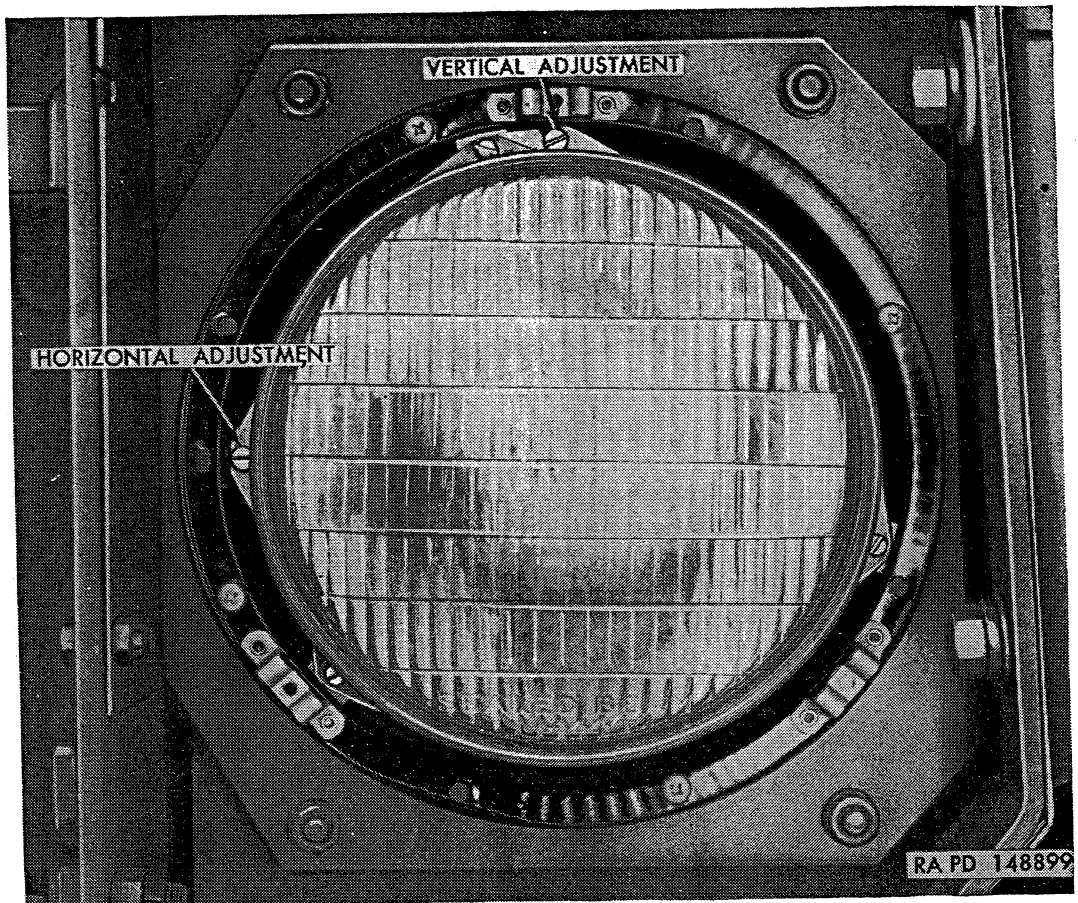

Figure 159. Headlight beam adjusting screws.

b. Sealed-Beam Lamp Unit Replacement (fig. 161).

(1) Removal.

- (a) Unlatch headlight brush guard door at top and swing door down. Remove three screws attaching headlight door (rim) to headlight body, and remove door.
- (b) Remove three screws attaching sealed-beam lamp unit retaining ring to headlight body, and remove ring.

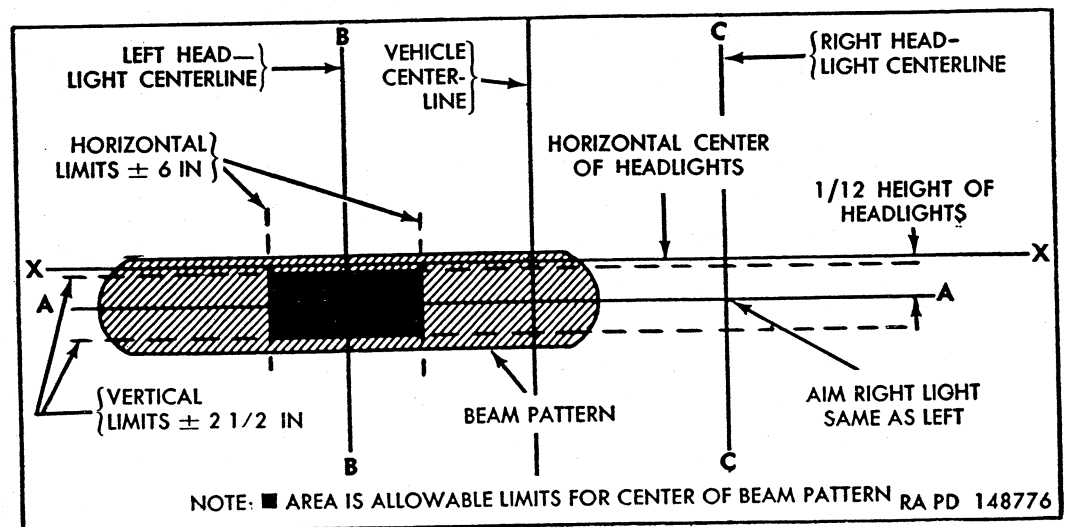

Figure 160. Headlight beam pattern.

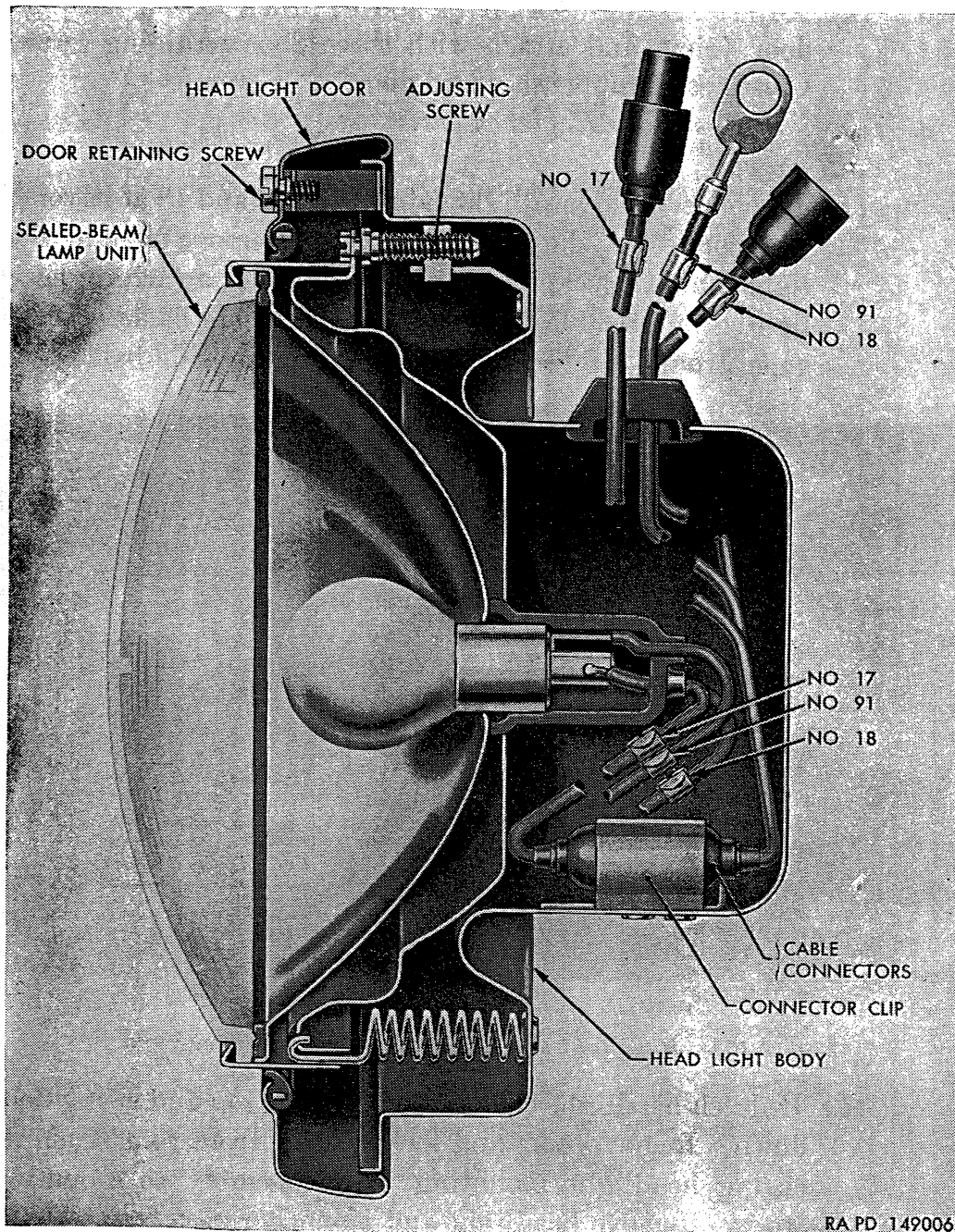

Figure 161. Sectional view of headlight.

- (c) Pull sealed-beam lamp unit from body, disengage connectors from clips in body, and disconnect cables at bayonet-type connectors.
- (2) *Installation.*
- (a) Connect cables on new sealed-beam lamp unit to cables in headlight body, making sure numbers on cable tags are matched. Engage connectors in clips in headlight body.
- (b) Position sealed-beam lamp unit in headlight body, install retaining ring, and attach with three screws.

- (c) Adjust headlight beam (a above); then install headlight door (rim) and attach with three door retaining screws. Close headlight brush guard door.
- c. *Headlight Assembly Replacement.*

(1) *Removal.*

- (a) Disconnect two headlight cables Nos. 17 and 18 at bayonet-type connectors shown in figure 162. Remove front marker light mounting cap screw and lockwasher attaching headlight ground cable No. 91 to radiator side baffle. Disengage ground cable from clip on radiator side baffle..

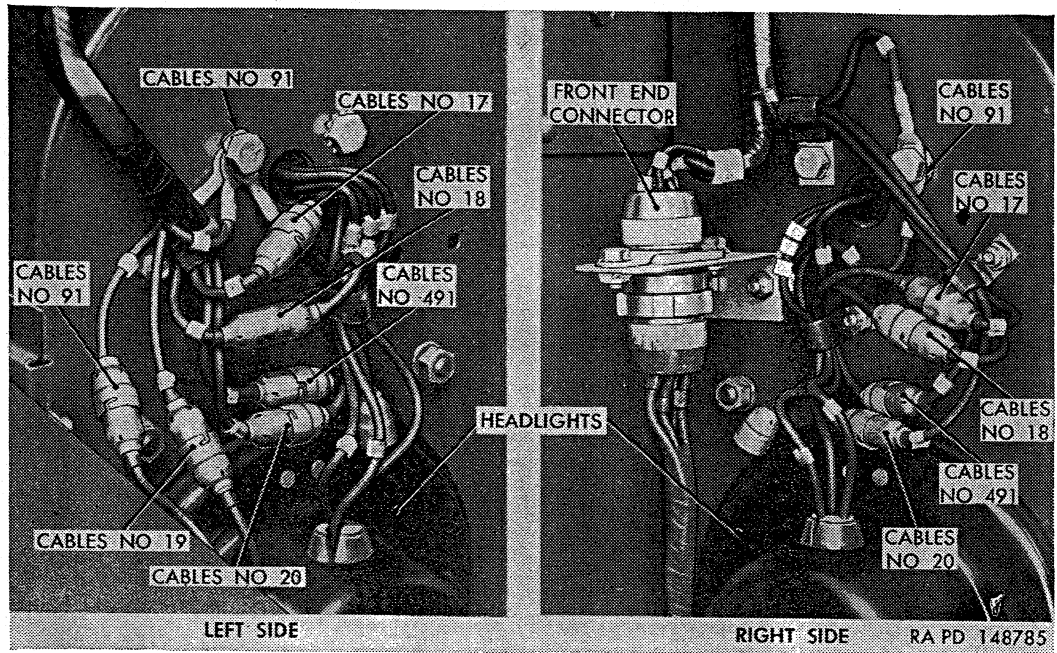

Figure 162. *Headlight and marker light wiring connections.*

- (b) Unlatch headlight brush guard door at top and swing door down. Remove nuts and lockwashers from four studs securing headlight mounting plate assembly to mounting studs. Remove headlight and mounting plate assembly.
- (c) Remove three screws attaching headlight door (rim) to headlight body, and remove door. Remove four nuts, lockwashers, and screws attaching headlight body to mounting plate. Remove headlight assembly from mounting plate.
- (2) *Installation.*
- (a) Examine insulators on headlight mounting studs in radiator side baffles. Replace insulator and stud assemblies if insulators are deteriorated.
- (b) Position headlight assembly, with door (rim) removed, in headlight mounting plate and attach with four screws, lockwashers, and nuts.



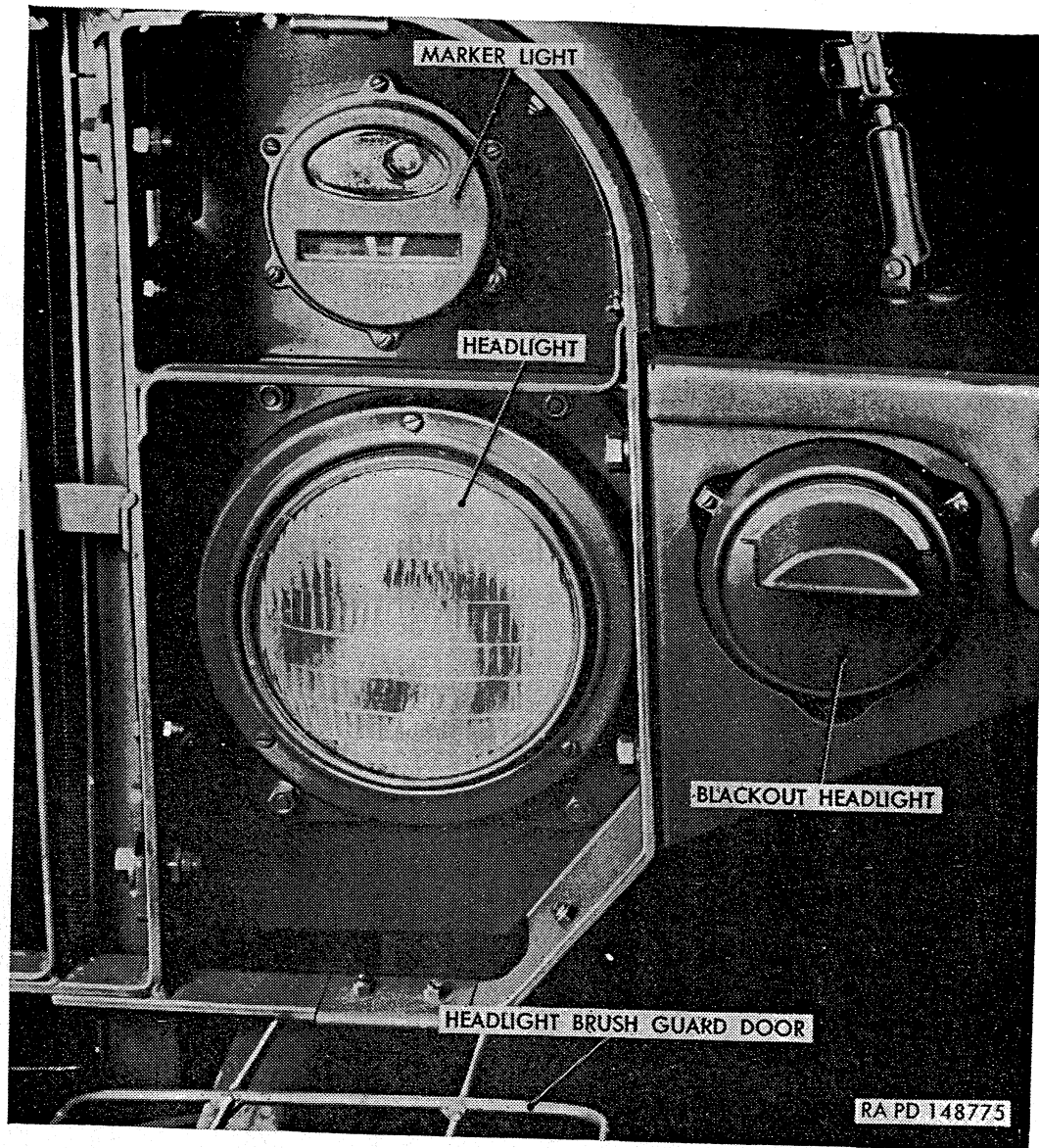

Figure 163. Front lights installed (left side shown).

- (c) Position headlight (fig. 163) and mounting plate assembly on studs in radiator side baffle and secure with four  $\frac{3}{8}$ -24 nuts and  $\frac{3}{8}$ -inch lockwashers.
- (d) Attach headlight ground cable No. 91 in conjunction with other ground cables under head of front marker light mounting cap screw, using external-teeth lockwasher under cap screw head. Connect the other two headlight cables Nos. 17 and 18 to harness cables having same numbers. Secure cables in clip on radiator side baffles.
- (e) Adjust headlight beam (*a* above). Install headlight door (rim) and attach with three screws. Close headlight brush guard door.

## 162. Blackout Headlight

### a. Sealed-Beam Lamp Unit Replacement (fig. 164).

(1) *Removal.* Unscrew three screws attaching door to light body and remove door. Pull sealed-beam lamp unit out of body, disengage connectors from clips in body, and disconnect cables at connectors.

(2) *Installation.* Connect cables on new sealed-beam lamp unit to cables in body, making sure numbers on cables are matched. Engage connectors in clips in body. Position sealed-beam unit in body, install door, and attach with three screws.

### b. Blackout Headlight Assembly Replacement.

(1) *Removal.*

(a) Disconnect light cables from harness cables at rear of left radiator side baffle (cable Nos. 91 and 19, fig. 162). Remove

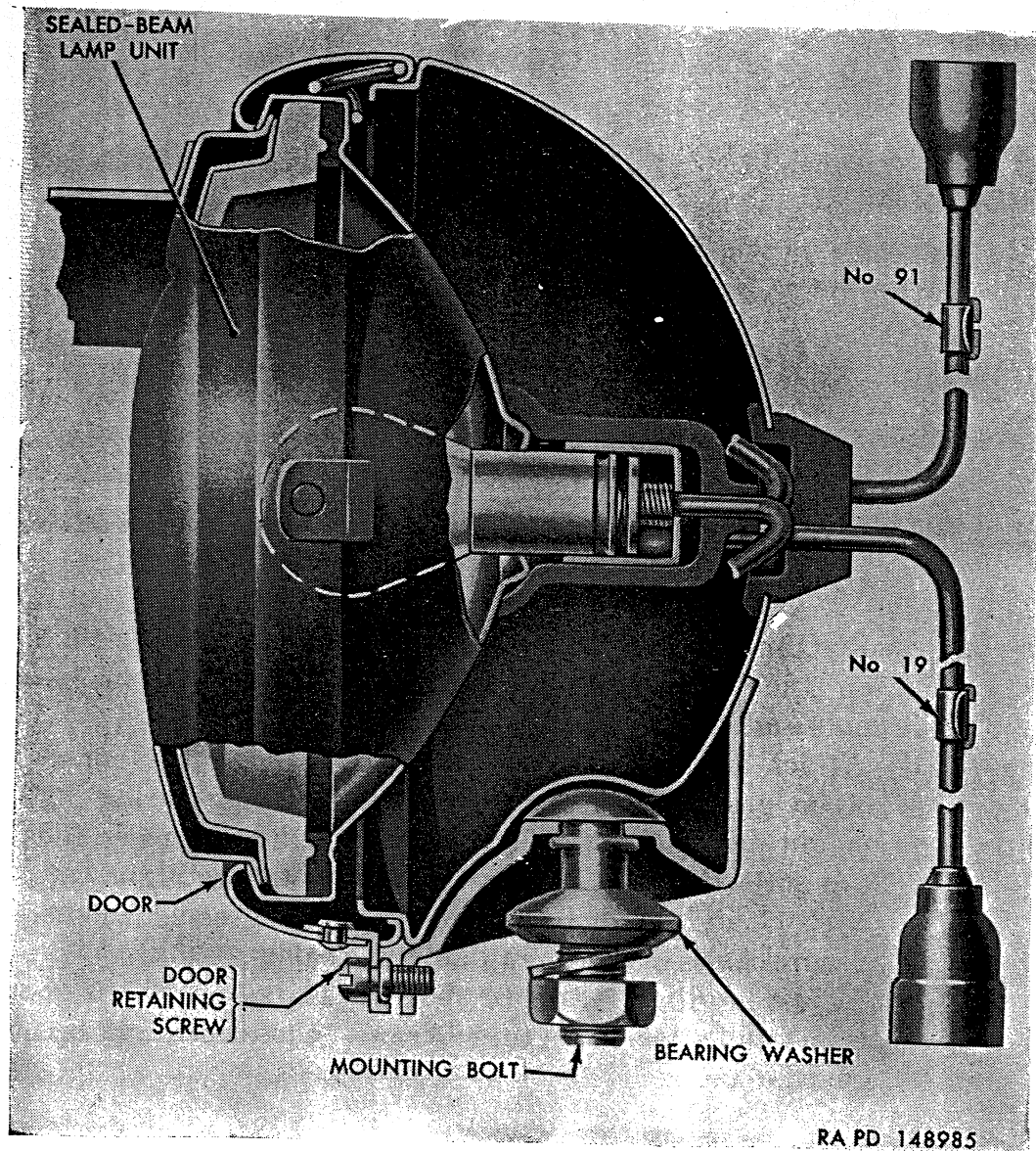

Figure 164. Sectional view of blackout headlight.



grommet from fender skirt, pull cables through hole in skirt, and disengage cables from clip on skirt.

(b) Remove nut, lockwasher, and bearing washer from light mounting bolt under fender. Remove light assembly from socket in support.

(2) *Installation.*

(a) Insert light cables through hole in support and position light assembly in socket in support with mounting bolt through bottom hole in socket. Install bearing washer, lockwasher, and nut on mounting bolt. Hold light with beam visor horizontal and pointing straight ahead while tightening nut.

(b) Insert cables through hole in fender skirt, place grommet around cables, and install in hole in skirt. Engage cables in clip on fender skirt.

(c) Connect light cables to harness cables at rear of radiator side baffle (fig. 162), making sure numbers on cables are matched.

### 163. Front Marker Lights

a. *Door and Lamp Replacement* (fig. 165).

(1) *Removal.* Unscrew six door retaining screws, then remove door and lens assembly and door sealing gasket. Press lamp in and turn counterclockwise to remove from socket.

(2) *Installation.* Press new lamp into socket and turn clockwise to lock in place. Examine door sealing gasket. If not in good condition, remove old gasket and press new gasket into groove in door. Install door and lens assembly and attach with six screws.

b. *Marker Light Assembly Replacement.*

(1) *Removal.*

(a) Disengage marker light cables from clip on back of radiator side baffle; then disconnect cables from harness at bayonet-type connectors (fig. 162).

(b) Remove two cap screws and lockwashers attaching light assembly to radiator side baffle. Note that ground cables No. 91 are secured under cap screw heads.

(2) *Installation.*

(a) Insert light cables through hole in radiator side baffle and position light assembly against baffle. Attach light assembly to baffle with two  $\frac{3}{8}$ -16 x  $\frac{5}{8}$  cap screws and  $\frac{3}{8}$ -inch external-teeth lockwashers, making sure ground cables No. 91 (fig. 162) are secured under one cap screw head.

(b) Connect cable having three tags (Nos. 20, 483, and 484, fig. 165) to harness cable No. 20 (fig. 162). Connect cable hav-

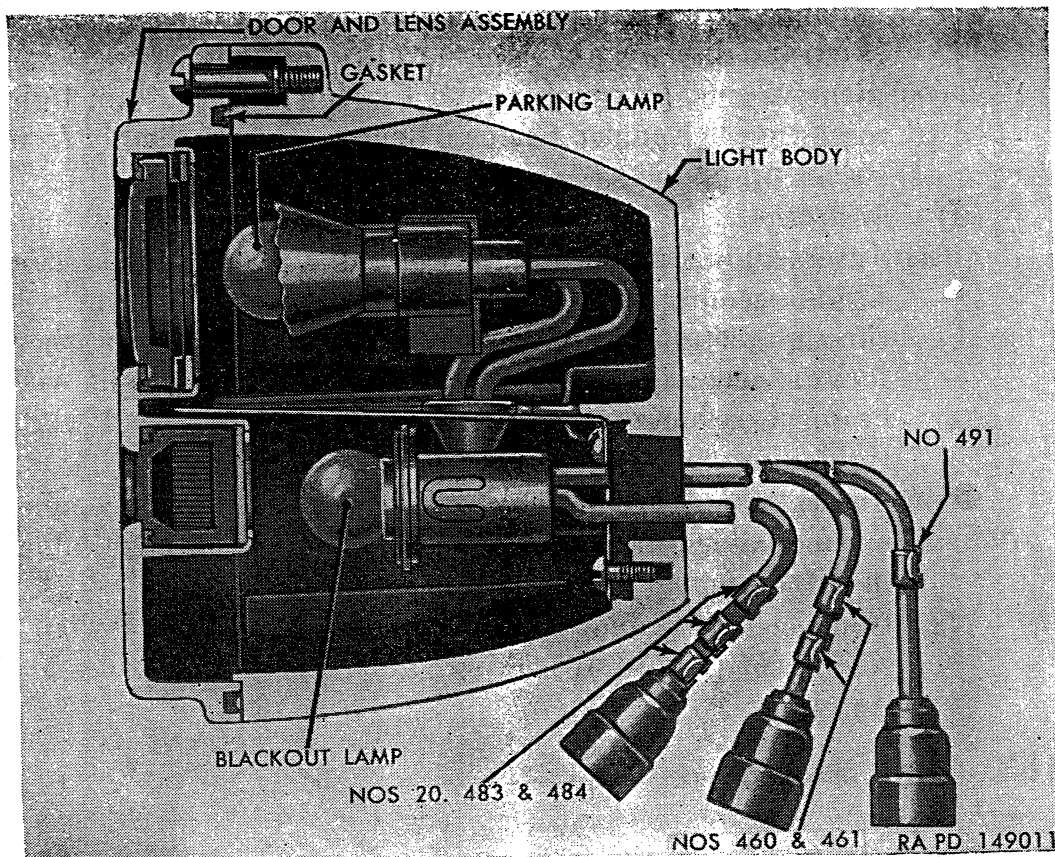

Figure 165. Sectional view of front marker light.

ing one tag (No. 491) to harness cable No. 491. The other cable (Nos. 460 and 461) is not used. Secure cables in clip on back of radiator side baffle.

## 164. Stop and Taillights

*a. Door and Lamp Replacement (fig. 166).* Door and lamp replacement procedure is same as described for front marker lights (par. 163a).

*b. Stop and Taillight Assembly Replacement.*

- (1) *Removal.* Disengage light cables from clip on rear of light mounting bracket. Disconnect light cables from harness cables at bayonet-type connectors. Remove two cap screws and lockwashers attaching light assembly to bracket. Note that clips are secured under cap screw heads.
- (2) *Installation.* Insert cables through hole in brackets, position light assembly against bracket, and attach with two  $\frac{3}{8}$ -16 x  $\frac{5}{8}$  cap screws and  $\frac{3}{8}$ -inch external-teeth lockwashers. Make sure clips are installed under cap screw heads. Connect light cables to harness cables, making sure cable numbers are matched. There are three light cables on left light and two on right light.

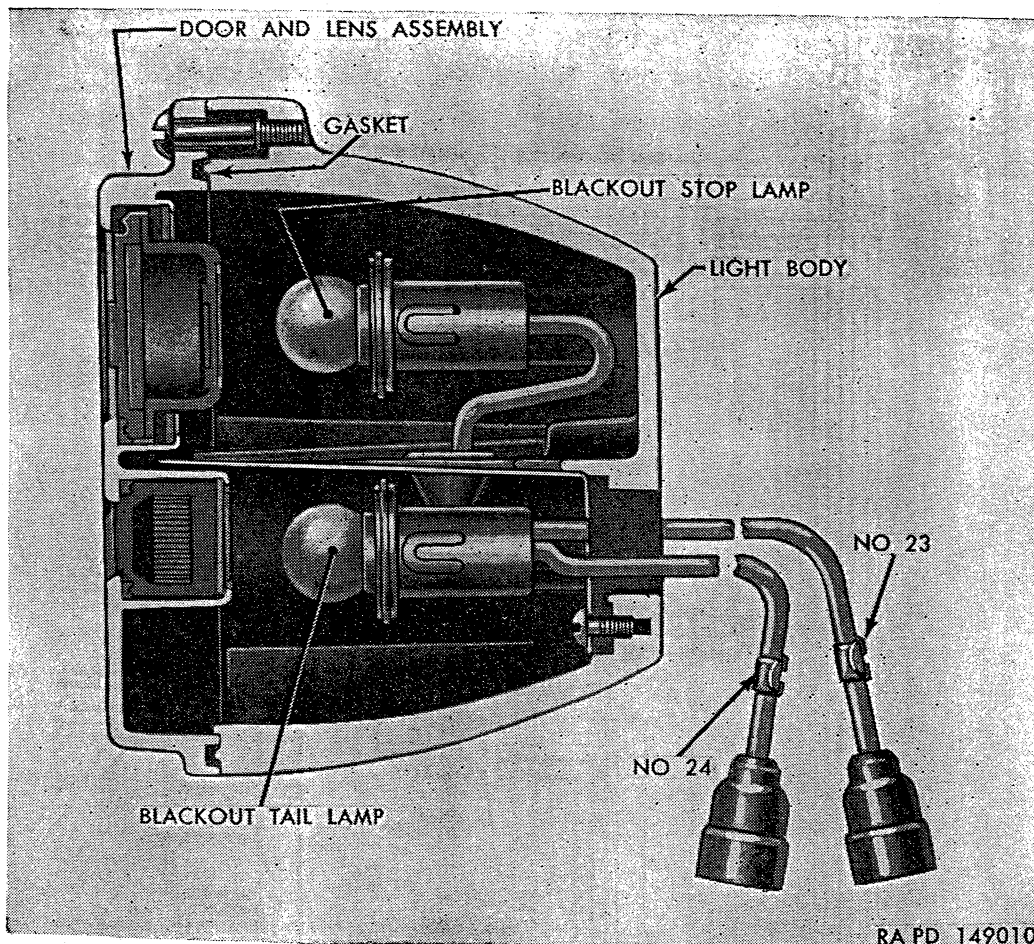

Figure 166. Sectional view of blackout stop and taillight.

## 165. Instrument Panel Lamps

*a. Removal.* Remove four screw and lockwasher assemblies attaching instrument cluster (fig. 30) to instrument board and tip cluster down. To remove either of the three lamps, press backshell in and turn counterclockwise to release from body. With backshell removed, lamp is exposed. Press lamp in and turn counterclockwise to release from socket.

*b. Installation.* Press new lamp into socket and turn clockwise to lock in place. Place backshell over body and turn clockwise to lock in place. Position instrument cluster on instrument board and attach with four screw and lockwasher assemblies.

## Section XIV. WIRING, HARNESSES, AND CIRCUITS

### 166. General

The electrical system is a 24-volt, waterproof sealed system. Sealing electrical system against moisture also accomplishes suppression of radio interference noise in conjunction with capacitors (condensers) and resistors installed in or connected to some electrical units (par. 188). Wiring circuit diagrams (figs. 167 and 168) show all wiring cir-



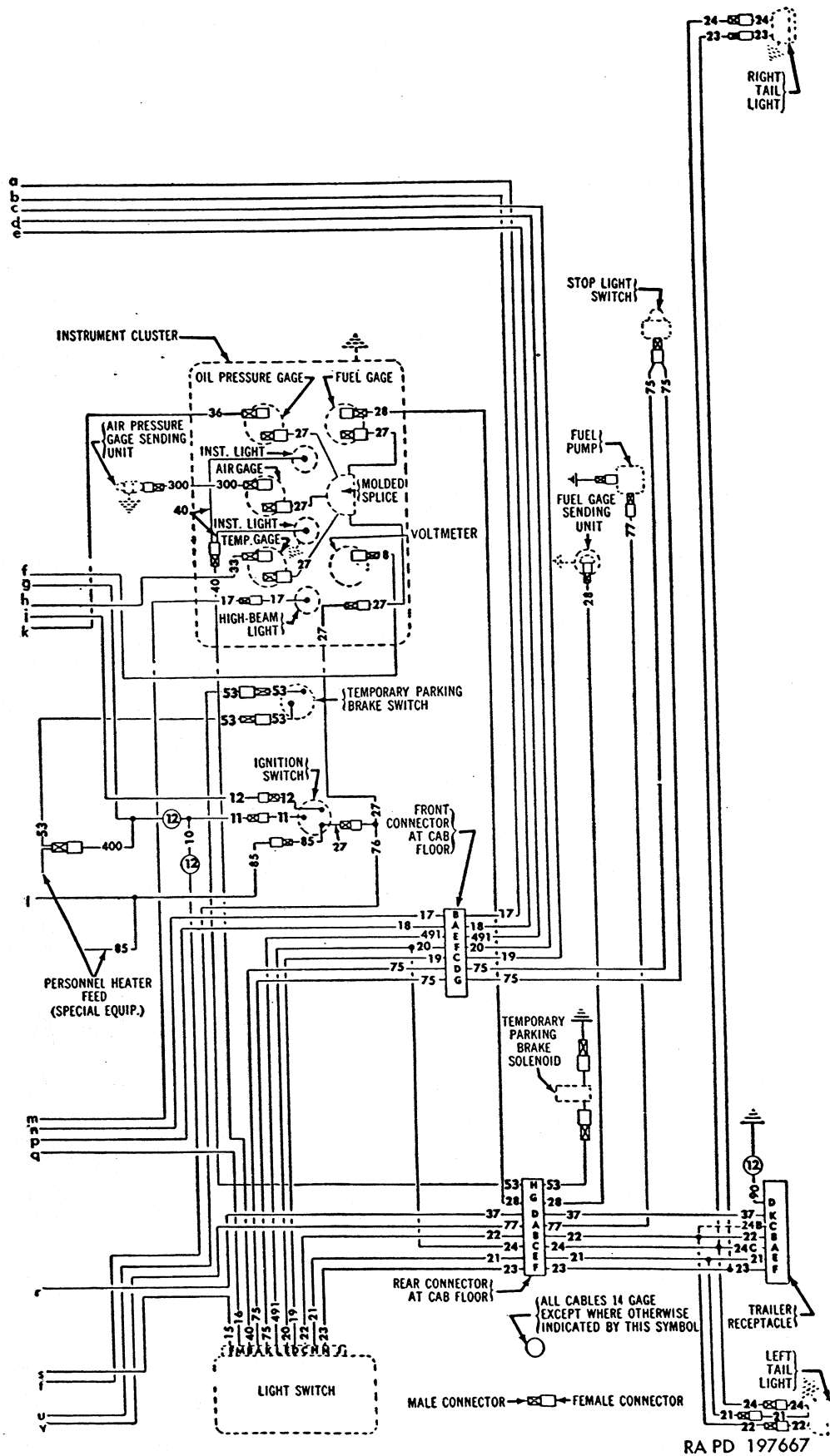

Figure 167—Continued.

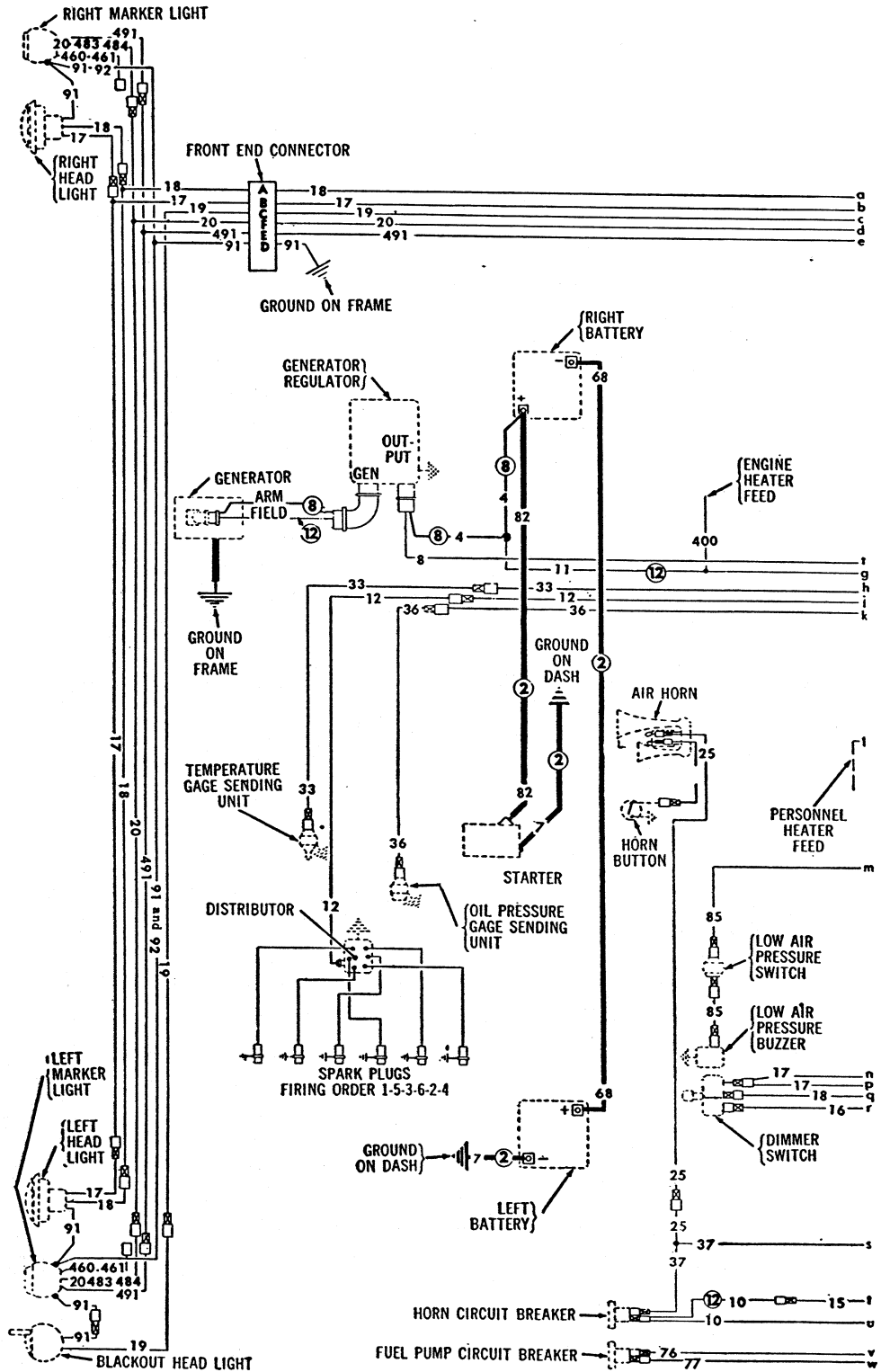

Figure 168. Wiring circuit diagram (late M135 and all other models).



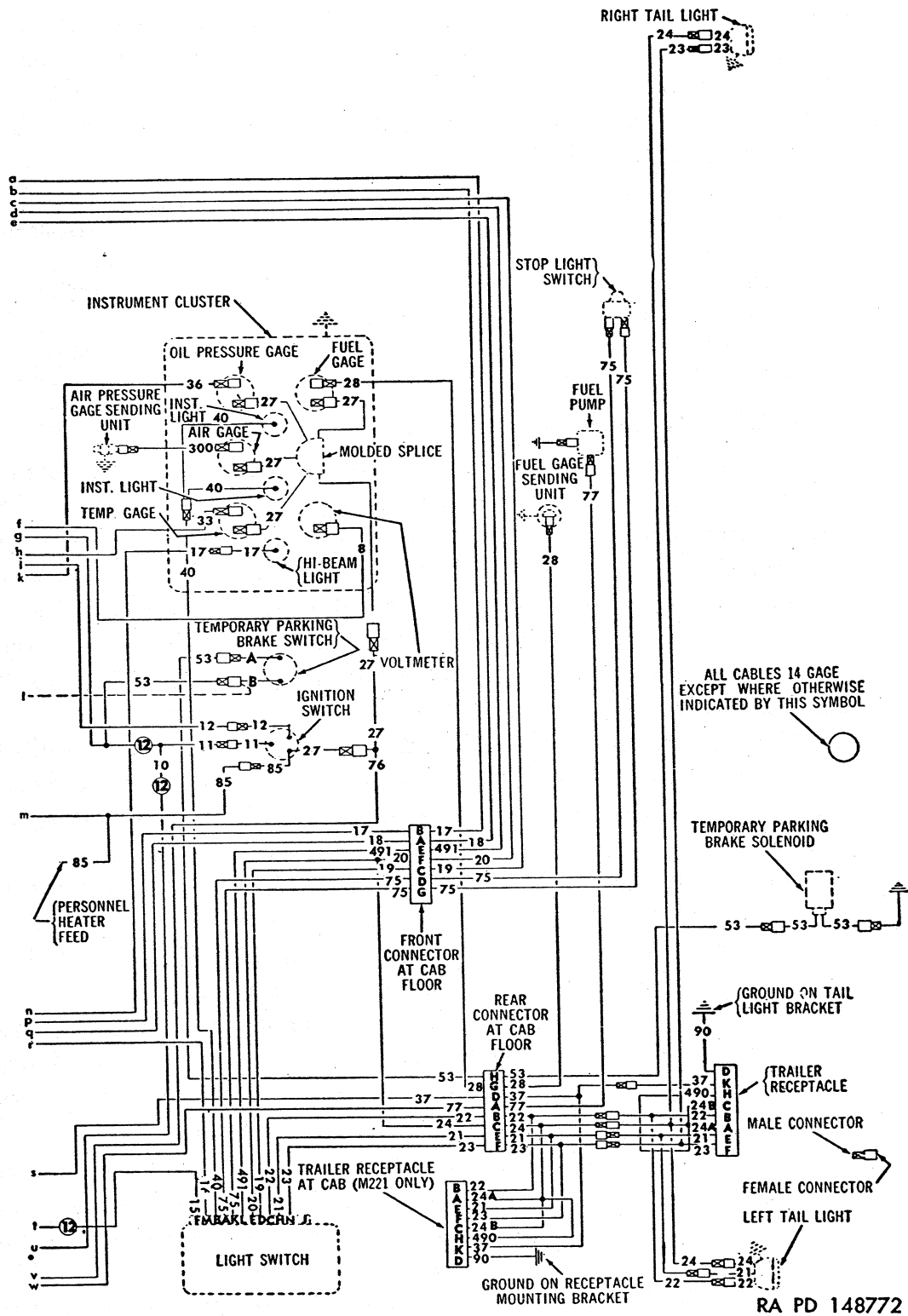

Figure 168—Continued.

cuits and connections, together with an outline of each electrical unit showing its relative location on the vehicle. Wiring circuit diagram shown in figure 167 applies to early M135 trucks. Wiring circuit diagram shown in figure 168 applies to late M135 trucks and all other models covered by this manual. Wiring circuit diagram for electrical system in shop van body (M220) is shown in figure 386. Units used in electrical system, with individual circuit diagrams, are described in other paragraphs as follows:

Ignition system.....	Paragraphs 121-124
Starting system.....	Paragraphs 150-152
Generating system.....	Paragraphs 153-156
Batteries and lighting system.....	Paragraphs 157-165
Instruments, gages, switches, sending units, and circuit breakers.....	Paragraphs 171-186
Radio interference suppression.....	Paragraphs 187-192

## 167. Circuits and Connections

*a.* Each cable for each circuit in electrical system is identified by a metal tag near each end of cable; metal tags bear standard ordnance circuit numbers. All cables in a single circuit are identified by the same number; however, when cables for a circuit are connected through more than one multiple plug and receptacle-type connector, they may connect to a different lettered terminal at each connector. Reference should be made to wiring circuit diagram (fig. 167 or 168) when making connections.

*b.* Grouped connections are made through multiple plug and receptacle type connectors. These connectors, shown on wiring circuit diagrams, are located at the points in (1) through (4) below on the vehicle.

- (1) Front end connector is located at right side of radiator above right headlight.
- (2) Engine connector, used only on early M135 trucks, is located under right battery at side of generator-regulator.
- (3) Two connectors are located in cab floor at left of driver's seat; disconnect is made from outside of cab below cab floor.
- (4) Multiple connectors are also used at generator, generator-regulator, light switch, and trailer receptacle.

*c.* Single cable connections are made through bayonet-type connections, held together by interlocking shells (fig. 169). Rubber grommets inside of shells protect the connections from moisture. Replacement of grommets is covered in paragraph 169.

*d.* Tables VII and VIII list each circuit number in the electrical system and briefly trace each circuit from its source to its end. A point-to-point check for circuit continuity can be made, using a conventional 24-volt test light or voltmeter equipped with long cables and suitable prods.

Table VII. Circuit Numbers and Descriptions (Early M135)

Circuit No.	Circuit description
4-----	Regulator output "C" terminal to right battery positive (+) terminal.
7-----	Ground terminal at dash through engine connector "E" terminal to ground on starter; also left battery negative (-) terminal to ground on dash.
8-----	Regulator output "B" terminal to battery-generator indicator terminal.
10-----	From tap junction on ignition switch feed cable (11) to light switch, horn, and auxiliary power outlet circuit breaker.
11-----	Regulator output "A" terminal to ignition switch.
12-----	Ignition switch through engine connector "A" terminal to distributor.
15-----	Light switch circuit breaker to light switch "F" terminal.
16-----	Light switch "M" terminal to dimmer switch "BATT" terminal.
17-----	Dimmer switch "H.B." terminal through front connector at cab floor "B" terminal, through front end connector "B" terminal to headlights; also from dimmer switch "H.B." terminal to Hi-Beam indicator lamp on instrument panel.
18-----	Dimmer switch "L.B." terminal through front connector at cab floor "A" terminal, through front end connector "A" terminal to headlights.
19-----	Light switch "D" terminal through front connector at cab floor "C" terminal, through front end connector "C" terminal to blackout headlight.
20-----	Light switch "E" terminal through front connector at cab floor "F" terminal, through front end connector "F" terminal to front marker lights.
21-----	Light switch "H" terminal through rear connector at cab floor "E" terminal to service taillight and trailer receptacle "E" terminal.
22-----	Light switch "C" terminal through rear connector at cab floor "B" terminal to service stop light and trailer receptacle "B" terminal.
23-----	Light switch "N" terminal through rear connector at cab floor "F" terminal to right blackout stop lamp and trailer receptacle "F" terminal.
24-----	From tap junction in front marker light feed cable (20) near front connector at cab floor through rear connector at cab floor "C" terminal to blackout taillights and trailer receptacle "A" and "C" terminals.
25-----	Horn circuit breaker through horn solenoid valve to horn button.
27-----	Ignition switch through molded splice to all gages.
28-----	Fuel gage through rear connector at cab floor "G" terminal to fuel gage sending unit.
33-----	Temperature gage through engine connector "C" terminal to temperature gage sending unit.
36-----	Oil pressure gage through engine connector "D" terminal to oil pressure gage sending unit.
37-----	Auxiliary power circuit breaker to auxiliary power outlet, and auxiliary power circuit breaker through rear connector at cab floor "D" terminal to trailer receptacle "K" terminal.
40-----	Light switch "B" terminal to instrument panel lights.

*Table VII. Circuit Numbers and Descriptions (Early M135)—Continued*

Circuit No.	Circuit description
49-----	Right battery positive (+) terminal to slave battery receptacle positive (+) terminal.
50-----	Slave battery receptacle negative (-) terminal to ground on dash.
53-----	From junction in ignition switch feed cable (11) to temporary parking brake switch; from temporary parking brake switch through rear connector at cab floor "H" terminal to temporary parking brake solenoid.
68-----	Right battery negative (-) terminal to left battery positive (+) terminal.
75-----	Light switch "A" terminal through front connector at cab floor "D" terminal to stop light switch, then back through front connector at cab floor "G" terminal to light switch "K" terminal.
76-----	From tap junction on cable No. 27 near ignition switch to fuel pump circuit breaker.
77-----	Fuel pump circuit breaker through rear connector at cab floor "A" terminal to fuel pump in fuel tank.
82-----	Right battery positive (+) terminal through engine connector "B" terminal to starter switch.
85-----	Ignition switch through low air pressure switch to low air pressure buzzer.
90-----	Trailer receptacle "D" terminal to ground.
91-----	From all front end lights through front end connector "D" terminal to ground on frame.
300-----	Air pressure gage to air gage sending unit.
460 and 461	Front marker light signal lamps, not used on these vehicles.
491-----	Light switch "L" terminal through front connector at cab floor "E" terminal, through front end connector "E" terminal to front marker lights.

*Table VIII. Circuit Numbers and Descriptions (Late M135 and All Other Models)*

Circuit No.	Circuit description
4-----	Regulator output "C" terminal to right battery positive (+) terminal.
7-----	Ground terminal on starter to ground at dash; also left battery negative (-) terminal to ground on dash.
8-----	Regulator output "B" terminal to battery-generator indicator terminal.
10-----	From tap junction on ignition switch feed cable (11) to horn circuit breaker.
11-----	From tap junction on regulator to battery cable (4) to ignition switch.
12-----	Ignition switch to distributor.
15-----	From No. 10 cable at horn circuit breaker to light switch "F" terminal.
16-----	Light switch "M" terminal to dimmer switch "BATT" terminal.

*Table VIII. Circuit Numbers and Descriptions (Late M135 and All Other Models)—Continued*

Circuit No.	Circuit description
17-----	Dimmer switch "H.B." terminal through front connector at cab floor "B" terminal, through front end connector "B" terminal to headlights; also from dimmer switch "H.B." terminal to hi-beam indicator lamp on instrument panel.
18-----	Dimmer switch "L.B." terminal through front connector at cab floor "A" terminal, through front end connector "A" terminal to headlights.
19-----	Light switch "D" terminal through front connector at cab floor "C" terminal, through front end connector "C" terminal to blackout headlight.
20-----	Light switch "E" terminal through front connector at cab floor "F" terminal, through front end connector "F" terminal to front marker lights.
21-----	Light switch "H" terminal through rear connector at cab floor "E" terminal to service taillight and trailer receptacle "E" terminal.
22-----	Light switch "C" terminal through rear connector at cab floor "B" terminal to service stop light and trailer receptacle "B" terminal.
23-----	Light switch "N" terminal through rear connector at cab floor "F" terminal to right blackout stop lamp and trailer receptacle "F" terminal.
24-----	From tap junction in front marker light feed cable (20) near front connector at cab floor through rear connector at cab floor "C" terminal to blackout taillights and trailer receptacle "A" and "C" terminals.
25-----	Horn circuit breaker through horn solenoid valve to horn button.
27-----	Ignition switch through molded splice to all gages.
28-----	Fuel gage through rear connector at cab floor "G" terminal to fuel gage sending unit.
33-----	Temperature gage to temperature gage sending unit.
36-----	Oil pressure gage to oil pressure gage sending unit.
37 (M221 only).	From horn circuit breaker through rear connector at cab floor "D" terminal to "K" terminal at both trailer receptacles.
40-----	Light switch "B" terminal to instrument panel lights.
53-----	From junction in ignition switch feed cable (11) to temporary parking brake switch; from temporary parking brake switch through rear connector at cab floor "H" terminal to temporary parking brake solenoid.
68-----	Right battery negative (-) terminal to left battery positive (+) terminal.
75-----	Light switch "A" terminal through front connector at cab floor "D" terminal to stop light switch, then back through front connector at cab floor "G" terminal to light switch "K" terminal.
76-----	From tap junction on cable No. 27 near ignition switch to fuel pump circuit breaker.
77-----	Fuel pump circuit breaker through rear connector at cab floor "A" terminal to fuel pump in fuel tank.
82-----	Right battery positive (+) terminal to starter switch.
85-----	Ignition switch through low air pressure switch to low air pressure buzzer.

*Table VIII. Circuit Numbers and Descriptions (Late M135 and All Other Models)—Continued*

Circuit No.	Circuit description
90.....	Trailer receptacle "D" terminal to ground.
91.....	From all front end lights through front end connector "D" terminal to ground on frame.
300.....	Air pressure gage to air gage sending unit.
460 and 461	Front marker light signal lamps, not used on these vehicles.
491.....	Light switch "L" terminal through front connector at cab floor "E" terminal, through front end connector "E" terminal to front marker lights.

e. Terminals at plug and receptacle-type connectors are identified by letters which appear on both halves of the connector. Table IX lists the lettered terminals at each connector, the circuit number of the cable connected at each terminal, and the name of the circuit carried through each terminal.

*Table IX. Connector Tabulation*

Plug and receptacle letter	Cable No.	Circuit
<i>Front end connector</i>		
A.....	18	Headlight low beam.
B.....	17	Headlight high beam.
C.....	19	Blackout headlight.
D.....	91	Ground on frame for all front end lights.
E.....	491	Front parking lights.
F.....	20	Front blackout marker lights.
G and H.....		Open.
<i>Engine connector (used only on early M135)</i>		
A.....	12	Distributor feed.
B.....	82	Starter.
C.....	33	Engine temperature gage.
D.....	36	Oil pressure gage.
E.....	7	Starter to dash ground.
<i>Front connector at cab floor</i>		
A.....	18	Headlight low beam.
B.....	17	Headlight high beam.
C.....	19	Blackout headlight.
D.....	75	Stop light switch feed.
E.....	491	Front parking lights.
F.....	20	Front blackout marker lights.
G.....	75	Stop light switch return.
H.....		Open.



Table IX. Connector Tabulation—Continued

Plug and receptacle letter	Cable No.	Circuit
<i>Rear connector at cab floor</i>		
A-----	77	Fuel pump.
B-----	22	Service stop light.
C-----	24	Blackout taillight.
D-----	37	Auxiliary power (early M135 and all M221).
E-----	21	Service taillight.
F-----	23	Blackout stop light.
G-----	28	Fuel gage.
H-----	53	Temporary parking brake.
<i>Light switch</i>		
A-----	75	Stop light switch feed.
B-----	40	Instrument lights.
C-----	22	Service stop light.
D-----	19	Blackout headlight.
E-----	20	Blackout marker and taillights.
F-----	15	Light switch feed.
H-----	21	Service taillight.
J-----		Open.
K-----	75	Stop light switch return.
L-----	491	Front parking lights.
M-----	16	Dimmer switch.
N-----	23	Blackout stop light.
<i>Regulator output Early M135</i>		
A-----	11	Ignition switch feed.
B-----	8	Battery-generator indicator.
C-----	4	Regulator-to-battery.
<i>Late M135 and all other models</i>		
B-----	8	Battery-generator indicator.
C-----	4	Regulator-to-battery.

## 168. Wiring and Harnesses

a. *Wiring.* All cables are covered with rubber insulation and cable ends are soldered to their respective plug or receptacle. All cables are 14 gage unless otherwise indicated on wiring circuit diagrams (figs. 167 and 168). Numeral within circle indicates gage size of cable when other than 14 gage is used. When replacing any cable, always use 14 gage unless otherwise indicated on wiring circuit diagram. Never replace a cable with one of a smaller size. Cable ends must be soldered to their respective plug or receptacle, using rosin flux solder. Never use acid flux solder on electrical connections.

b. *Harnesses.*

- (1) When a group of cables lead from one general location on the vehicle to another, these cables are grouped together to form a harness. Harnesses are wound with waterproof electrical tape. Ends of harnesses usually terminate at multiple plug and receptacle-type connectors; however, one or more single cables may branch out from various points on a harness.
- (2) Any harness is readily replaceable by disconnecting each end and single cables leading from the harness, and disengaging harness from clips securing the harness at various points on the vehicle. On multiple connectors, make sure locating key and keyway are alined before attempting to insert plug. Do not force plug into receptacle. If properly alined, plug will enter receptacle under light pressure. Make sure rubber sealing gasket or ring is in place before tightening connector nuts.
- (3) Following is a list of harnesses used on these vehicles, together with a brief description of their location on the vehicle.
  - (a) *Headlight wiring harness.* This harness leads from front end connector at right side of radiator through spliced junctions, with cables leading to right front lights and across top of radiator to left front lights.
  - (b) *Engine wiring harness.* On early M135 trucks, engine harness carries cables from engine connector (at side of generator-regulator) to starter, distributor, and temperature and oil pressure gage sending units. On late M135 and all other models, engine harness carries cables from bayonet-type connectors at cowl to distributor, and temperature and oil pressure gage sending units.
  - (c) *Instrument panel-to-regulator-and-engine wiring harness.* This harness, having single cable bayonet-type connectors connected to various units under instrument panel, terminates at two multiple plug and receptacle type connectors on early M135 trucks, one connecting to generator-regulator output connector, the other connecting to engine connector at side of regulator. On late M135 and all other models, the engine connector is not used; each cable terminates at a bayonet-type connector which connects directly to engine harness.
  - (d) *Instrument panel-to-cab-floor wiring harness.* This harness leads from light switch to two connectors at cab floor at left of driver's seat, with individual cables leading to instrument panel lights, dimmer switch, horn circuit

breaker, fuel pump circuit breaker, fuel gage, and temporary parking brake switch.

- (e) *Cab-to-headlight wiring harness.* This harness carries cables from front connector at cab floor, under back of cab to right frame side member, then forward inside of frame side member to front end connector at right side of radiator. Two cables branch out from harness and connect to stop lamp switch through a double bayonet-type connector.
- (f) *Chassis wiring harness.* This harness leads from rear connector at cab floor rearward inside of frame left side member. Near rear end of vehicle, it is divided at spliced junctions, with one group of cables leading to right stop and taillight, and one group leading to left stop and taillight and trailer receptacle. On tractor truck M221, this harness is divided into two harnesses, front and rear, connected together near back of cab through bayonet-type connectors. The front harness branches off to trailer receptacle installed at rear of cab.

### 169. Bayonet-Type Connectors

*a. Description.* Single, and in some cases double, cable connections are made through bayonet-type connectors which are held together by interlocking shells (fig. 169). Terminals are crimped onto end of each cable. Rubber grommet is held in place on end of cable by a metal bushing. When cable terminals are inserted into ends of

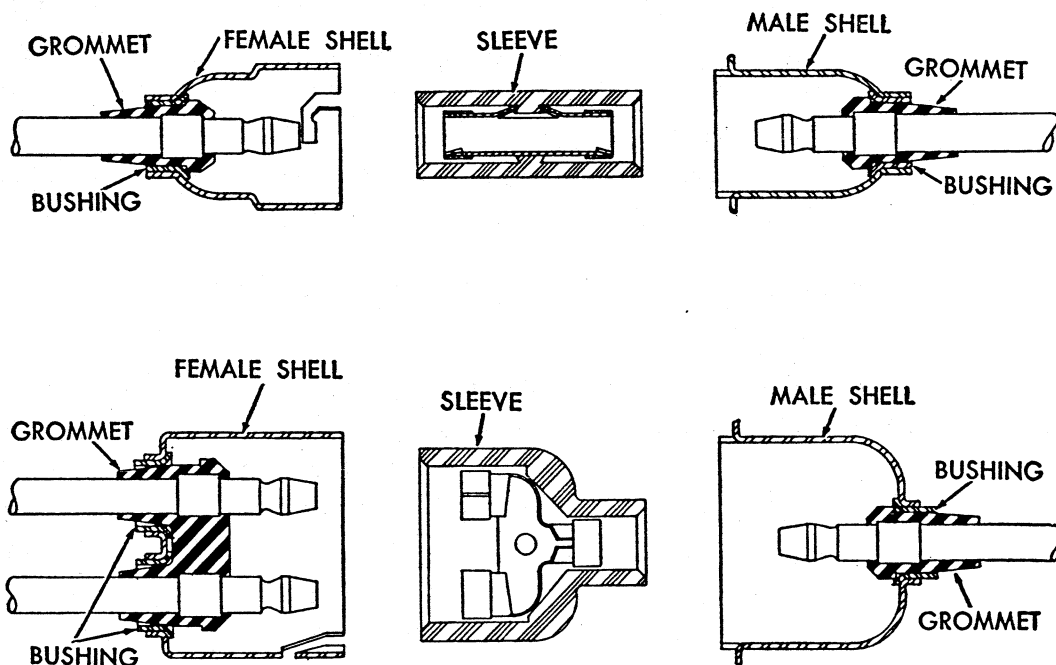

RA PD 148760

Figure 169. Bayonet-type cable connector components.

sleeve or in connecting unit and the male and female shells are locked together, the shells force the rubber grommets against ends of sleeve or unit terminal, providing a moisture-proof connection.

*b. Inspection.*

- (1) Inspect cable terminal for corrosion and clean if necessary. Make sure terminal is securely crimped onto end of cable and that no wires are broken. If insulation at terminal is cracked or if bare wires are exposed, replace cable or harness assembly.
- (2) Examine grommet for evidence of hardening or deterioration. Outer end must form a moisture-proof seal against end of connector sleeve. If any damage is evident, replace grommet (*c* and *d* below).
- (3) Inspect shells for distortion and for broken ears on male shells. Replace any shell which is broken (*c* and *d* below).

*c. Disassembly.* Slide connector shell back on cable to expose bushing and grommet. Force bushing back off grommet, pull grommet off cable end, then remove bushing and shell.

*d. Assembly.*

- (1) To facilitate assembling grommet on cable, apply a thin coat of hydraulic brake fluid to end of cable.
- (2) Place connector shell, bushing, and grommet on end of cable in positions shown in upper view in figure 170.
- (3) Slide bushing against shoulder on grommet as shown in center view in figure 170.
- (4) Grip grommet and bushing between thumb and finger and pull cable back through grommet until outer end of grommet just covers outer shoulder on cable terminal as shown in lower view in figure 170.
- (5) Wipe hydraulic brake fluid off cable terminal after completing assembly.

## **170. Auxiliary Power Outlet (Early M135)**

(fig. 176)

Auxiliary power outlet, used only on early M135 trucks, is an electrical receptacle mounted on steering column brace in cab. Circuit to auxiliary power receptacle in cab and to auxiliary power terminal "K" connection at trailer receptacle is fed from hot terminal on ignition switch through a 15-amp circuit breaker which is also mounted on steering column brace in cab. When not in use, a sealing cap is screwed onto receptacle. Cap is secured to cowl by a ball-type chain. Auxiliary power receptacle is a part of the instrument panel-to-cab-floor wiring harness assembly.

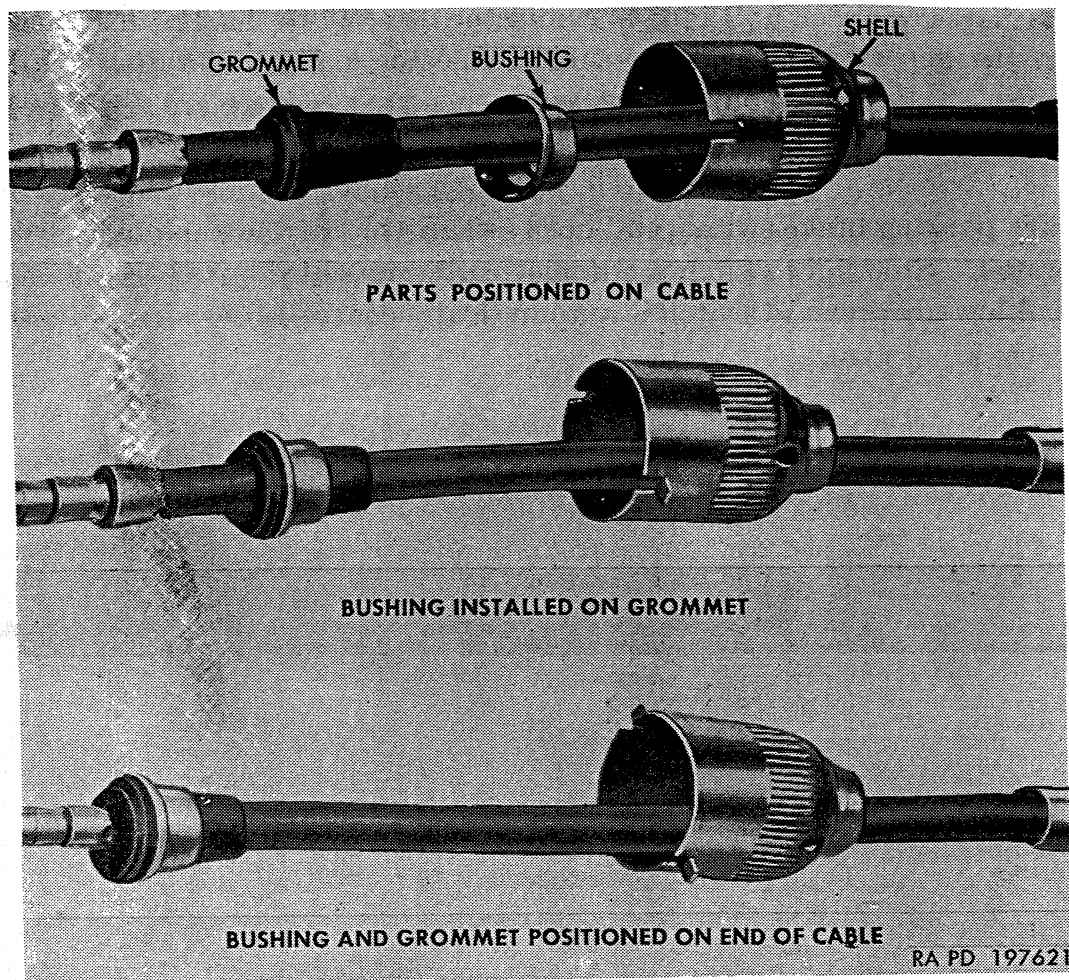

Figure 170. Installation of connector components.

## Section XV. INSTRUMENTS, GAGES, SWITCHES, SENDING UNITS, AND CIRCUIT BREAKERS

### 171. General

*a. Instrument Cluster.* The instrument cluster, located in center of instrument board, contains the battery-generator indicator, engine temperature gage, oil pressure gage, fuel gage, air pressure gage, and speedometer (C, fig. 30). Instrument lights and high-beam indicator light are mounted on back of instrument cluster (fig. 171). Instrument cluster may be removed as a complete assembly to facilitate replacement of the individual units.

*b. Gages and Sending Units.* All gages, except the speedometer are electrically operated, and are activated only when the ignition switch is turned on. Circuits to all gages are fed through the ignition switch; circuits are grounded at the sending units which control the gage actions. Sending units are actually rheostat-type resistance units which automatically increase or decrease resistance in gage circuits according to condition existing in the system controlling each circuit.

Battery-generator indicator is connector directly to the "B" terminal on the generator-regulator output connector and is activated at all times. Gage and sending unit replacement procedures are described in individual paragraphs.

*c. Switches.* Ignition switch, light switch, dimmer switch, temporary parking brake switch, and horn switch (button) are manually operated. Stop light switch is automatically controlled by brake system, and low air pressure switch is automatically controlled by air pressure in the air system.

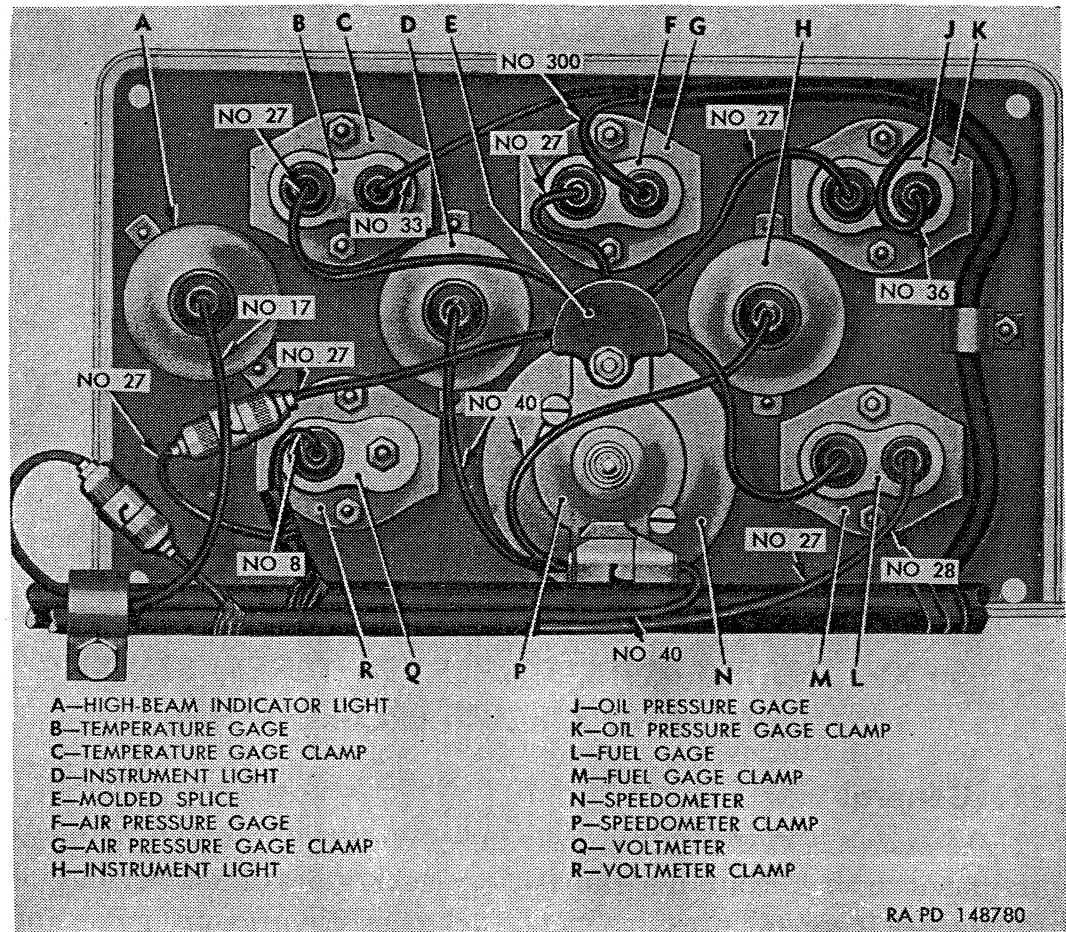

Figure 171. Instrument cluster, rear view.

*d. Circuit Breakers.* On early M135 trucks, four automatic reset-type circuit breakers are used in the electrical system, protecting the fuel pump, light, horn, and auxiliary power circuits. On late M135 and all other models, light system circuit breaker is incorporated in the light switch, and the auxiliary power outlet is omitted, leaving only the horn and fuel pump circuit breakers. Circuit breakers are mounted on under side of steering gear cowl bracket as shown in figures 176 and 177. Connections at all circuit breakers are made through bayonet-type connectors.



## 172. Instrument Cluster

### a. Removal.

- (1) Disconnect speedometer flexible shaft from speedometer at rear of instrument cluster (fig. 171).
- (2) Remove four cap screw and lockwasher assemblies attaching instrument cluster to instrument board. Tip cluster out of instrument board, disengaging harness from clip at right side of cluster.
- (3) Replacement of individual units in instrument cluster can be made with cluster in this position. To remove complete cluster assembly, disconnect all harness cables from units on cluster.

### b. Installation.

- (1) If instrument cluster (fig. 171) was completely removed, position cluster at instrument board and connect harness cables to instrument cluster units. Refer to figure 171 or to wiring circuit diagram (fig. 167 or 168) to identify number on each cable and unit to which it connects.
- (2) Engage harness in clip at right end of instrument cluster, position cluster against instrument board, and attach with four  $\frac{5}{16}$ -24 x  $\frac{5}{8}$  cap screws with external-teeth lockwashers.
- (3) Connect speedometer flexible shaft to speedometer at rear of instrument cluster.

## 173. Oil Pressure Gage and Sending Unit

a. *General.* Oil pressure gage registers oil pressure in engine main oil gallery. Gage circuit is controlled by a sending unit mounted on right side of engine above starter and connected to oil line leading from engine oil gallery to oil filter (fig. 172).

### b. Oil Pressure Gage Removal (fig. 171).

- (1) Remove instrument cluster from instrument board (par. 172a).
- (2) Disconnect two cables from oil pressure gage terminals.
- (3) Remove nut and lockwashers from two studs attaching oil pressure gage clamp (k) to back of gage. Remove clamp; then pull gage out front of cluster.

### c. Oil Pressure Gage Installation (fig. 171).

- (1) Position gage in instrument cluster from front side. Place oil pressure gage clamp (k) over two studs on gage, install lockwasher and nut on each stud, and tighten nuts.
- (2) Connect cable No. 36 to female terminal on gage, and connect cable No. 27 from molded splice to male terminal on gage.
- (3) Install instrument cluster (par. 172b).

*d. Oil Pressure Gage Sending Unit Removal* (fig. 172). Disconnect cable No. 36 from terminal on top of sending unit. Unscrew sending unit from bracket on engine cylinder block.

*e. Oil Pressure Gage Sending Unit Installation* (fig. 172). Thread sending unit into bracket on engine cylinder block and tighten. Do not use sealing compound on sending unit threads as the electrical circuit is grounded through the sending unit mounting. Connect cable No. 36 to terminal on top of sending unit.

#### 174. Fuel Gage and Sending Unit

*a. General.* Fuel gage in instrument cluster registers level of fuel in fuel tank. Fuel gage circuit is controlled by a sending unit installed in fuel tank. Sending unit action is controlled by a float and linkage mechanism which extends down into tank.

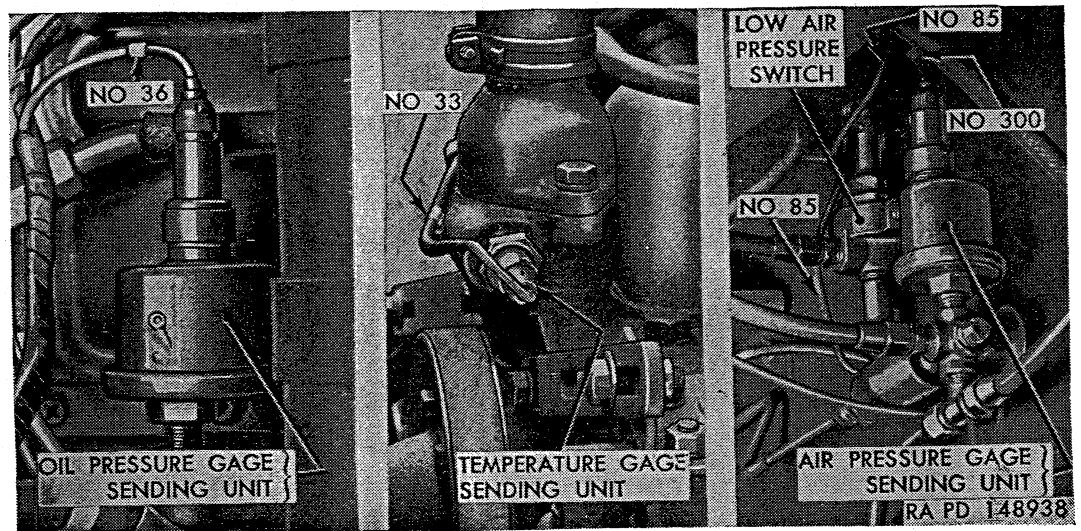

Figure 172. Sending units and low air pressure switch installed.

*b. Fuel Gage Replacement* (fig. 171). Fuel gage replacement procedure is same as for oil pressure gage (par. 173). Cable No. 27 from molded splice connects to gage male terminal, and cable No. 28 connects to gage female terminal.

*c. Fuel Gage Sending Unit Removal.* Disconnect cable from sending unit terminal on top of fuel tank. Remove five screws and gaskets attaching sending unit to tank. Lift complete sending unit and float mechanism out of tank. Discard gasket.

*d. Fuel Gage Sending Unit Installation.* Coat new cork gasket with liquid-type gasket cement and place gasket on tank. Insert float mechanism into tank and position with sending unit terminal pointing toward frame side rail. Install five screws, with copper and asbestos gasket on each screw, and tighten. Connect cable No. 28 to sending unit terminal.

## 175. Temperature Gage and Sending Unit

*a. General.* Temperature gage in instrument cluster registers temperature of engine coolant in degrees Fahrenheit. Temperature gage circuit is controlled by a temperature gage sending unit installed in engine thermostat housing as shown in figure 172.

*b. Temperature Gage Replacement* (fig. 171). Temperature gage replacement procedure is same as for oil pressure gage (par. 173). Cable No. 27 from molded splice connects to gage male terminal, and cable No. 33 connects to gage female terminal.

*c. Temperature Gage Sending Unit Removal* (fig. 172). Disconnect cable No. 33 from sending unit terminal. Unscrew sending unit from thermostat housing.

*d. Temperature Gage Sending Unit Installation* (fig. 172). Thread sending unit into engine thermostat housing and tighten. Do not use sealing compound on sending unit threads as the electrical circuit is grounded through the sending unit mounting. Connect cable No. 33 to sending unit terminal.

## 176. Air Pressure Gage and Sending Unit

*a. General.* Air pressure gage in instrument cluster registers air pressure in air system. Air pressure gage circuit is controlled by a sending unit. Sending unit (fig. 172) is mounted on cowl inside cab and is connected to air system at air line junction fitting on cowl.

*b. Air Pressure Gage Replacement* (fig. 171). Air pressure gage replacement procedure is same as for oil pressure gage (par. 173). Cable No. 27 from molded splice connects to gage male terminal, and cable No. 300 connects to gage female terminal.

*c. Air Pressure Gage Sending Unit Removal* (fig. 172). Exhaust air pressure from air system. Disconnect cable No. 300 from sending unit terminal. Unscrew sending unit from air line junction fitting on cowl.

*d. Air Pressure Gage Sending Unit Installation* (fig. 172). Thread sending unit into top of air line junction fitting on cowl and tighten. Do not use sealing compound on sending unit threads as the electrical circuit is grounded through the sending unit mounting. Connect cable No. 300 to sending unit terminal.

## 177. Voltmeter (Battery-Generator Indicator)

The voltmeter registers the condition of the electrical system as described in paragraph 29. Replacement procedure is same as for oil pressure gage (par. 173). Cable No. 8 connects to indicator terminal.

## 178. Speedometer and Flexible Shaft (fig. 171)

*a. General.* Speedometer, mounted in top center of instrument cluster, registers truck speed in miles-per-hour, and records accumu-

lated mileage. The "LOW RANGE" and "HIGH RANGE" markings around speedometer face are important with regard to driving the vehicle (par. 40). Speedometer is driven by a flexible shaft which is connected to a fitting at the transfer.

*b. Speedometer Removal.*

- (1) Remove instrument cluster from instrument board (par. 172a).
- (2) Disengage cable connector from clip on speedometer clamp.
- (3) Remove nut and lock washer from two speedometer clamp studs. Remove cable connector clip from one stud, and remove molded splice from other stud.
- (4) Remove long stud and lockwasher securing clamp to speedometer. Remove clamp, then remove speedometer from front of cluster.

*c. Speedometer Installation.*

- (1) Position speedometer in instrument cluster from front side. Position clamp over speedometer at back of cluster; install long stud and lockwasher, and nut and lockwasher attaching clamp to speedometer.
- (2) Place molded splice on long stud and secure with lockwasher and nut. Place cable connector clip on short stud and secure with lockwasher and nut. Engage cable connector in clip.
- (3) Install instrument cluster in instrument board (par. 172b).

*d. Speedometer Flexible Shaft Removal.*

- (1) Disconnect speedometer flexible shaft from speedometer and from speedometer fitting at transfer.
- (2) Remove three flexible shaft clips, one at front of cowl above engine and two at floor sills under cab. Withdraw flexible shaft through hole in cowl, and remove from under cab.

*e. Speedometer Flexible Shaft Installation.*

- (1) The square end of the speedometer flexible shaft connects to the speedometer, and the tongued end connects to fitting at transfer. Insert square end of flexible shaft through hole in cowl and position grommet around shaft in cowl.
- (2) Connect flexible shaft at speedometer and at fitting on transfer.
- (3) Install three flexible shaft clips, one on cowl above engine and two on floor sills under cab.

## **179. Ignition Switch**

*a. General.* Lever-type ignition switch is mounted at extreme left side of instrument board. Operation of ignition switch is explained in paragraph 20. Wiring connections at switch are made through bayonet-type connectors.

*b. Removal.*

- (1) Remove screw and lockwasher attaching switch lever to switch shaft. Pull lever off shaft.
- (2) Remove nut and lockwasher from ignition switch; then remove switch from under instrument board. Ignition switch name plate will come off instrument board.
- (3) Disconnect harness cable No. 11 from switch cable No. 11; then disconnect three other harness cables from switch cables.

*c. Installation.*

- (1) Connect harness cables to ignition switch cables, making sure cable numbers are matched. Do not connect cables No. 11 until the other three cables have been connected.
- (2) Insert shaft end of switch through hole in instrument board from back side, with locating pin in switch engaging locating hole in panel. Install name plate, lockwasher, and nut on switch and tighten firmly.
- (3) Install switch lever on switch shaft and attach with screw and lockwasher.

## **180. Main Light Switch**

*a. General.* Light switch (Y, fig. 29) is mounted on instrument board at left of steering column. Switch is three-lever-type, with main switch lever, auxiliary lever, and switch locking lever. Operation of light switch is described in paragraph 45. Wiring connections at switch are made through a multiple plug and receptacle-type connector at back of instrument board.

*b. Removal.* Disconnect wiring harness connector from light switch at back of instrument board. Remove four screws and lockwashers attaching light switch to instrument board; then remove switch from back of panel. Switch name plate will come off when two upper screws are removed.

*c. Installation.* Position light switch in instrument board from back side and attach with four screws and lockwashers. Switch name plate must be installed under the two upper screw heads. Tighten screws. Connect wiring harness connector to light switch connector.

## **181. Temporary Parking Brake Switch**

*a. General.* Temporary parking brake switch (U, fig. 29), mounted on instrument board above steering column, is a lever-type switch which controls electrical circuit to temporary (electric) parking brake solenoid. Use of switch is described in paragraph 43. Wiring connections at switch are made through bayonet-type connectors.

*b. Replacement.* Replacement procedures for temporary parking brake switch are same as for ignition switch (par. 179). Harness cables No. 53 connect to switch cables.

## 182. Dimmer Switch

(fig. 173)

*a. General.* Dimmer switch is mounted under toe pan at left side, with switch button extending up through toe pan into cab, accessible to driver's left foot. Dimmer switch selects headlight high or low beam when headlight circuit is energized by the main light switch (par. 45c).

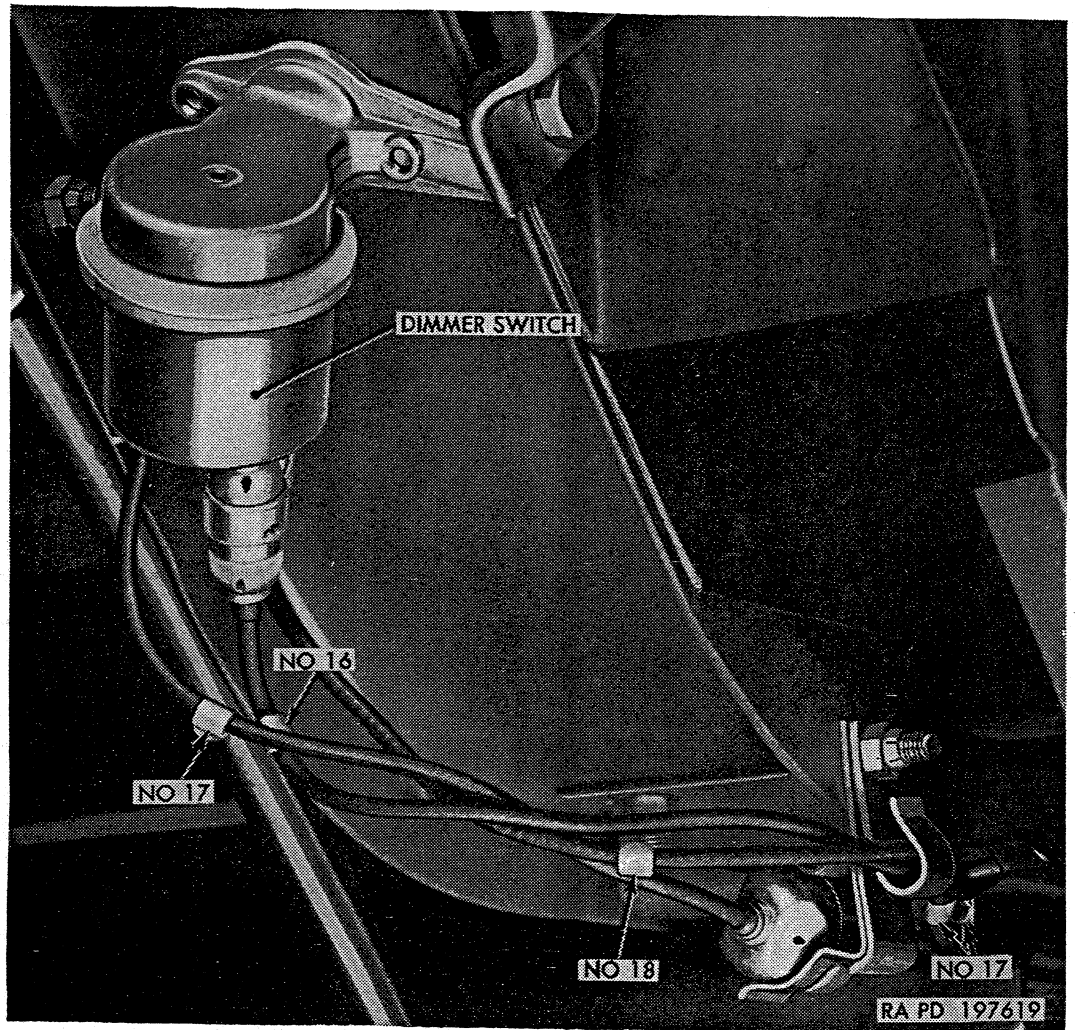

Figure 173. Dimmer switch installed.

### *b. Removal.*

- (1) Disengage cable connector from clip on cab floor sill. Disconnect harness cables from switch cable and from terminals at switch.
- (2) From inside cab, remove two screws and lockwashers attaching dimmer switch to under side of toe pan and remove switch.

### *c. Installation.*

- (1) Position switch under toe pan, with switch plunger extending up through toe pan. Attach switch to toe pan with two screws and lockwashers, installed from inside cab.



- (2) Connect the two-cable harness connector (cables No. 17) to switch cable connector No. 17; engage connector in clip on floor sill. Connect harness cable No. 16 to switch "BATT" terminal, and connect harness cable No. 18 to switch "LB" terminal.

### 183. Stop Light Switch

#### *a. General.*

- (1) Hydraulically operated stop light switch (fig. 174), used on all models, except truck tractor M221, is connected into hydraulic brake line at frame right side member ahead of rear air tank. When brakes are applied, hydraulic pressure closes switch contacts, completing circuit to blackout or service stop light, depending upon which circuit is energized through the main light switch (par. 45*b*).

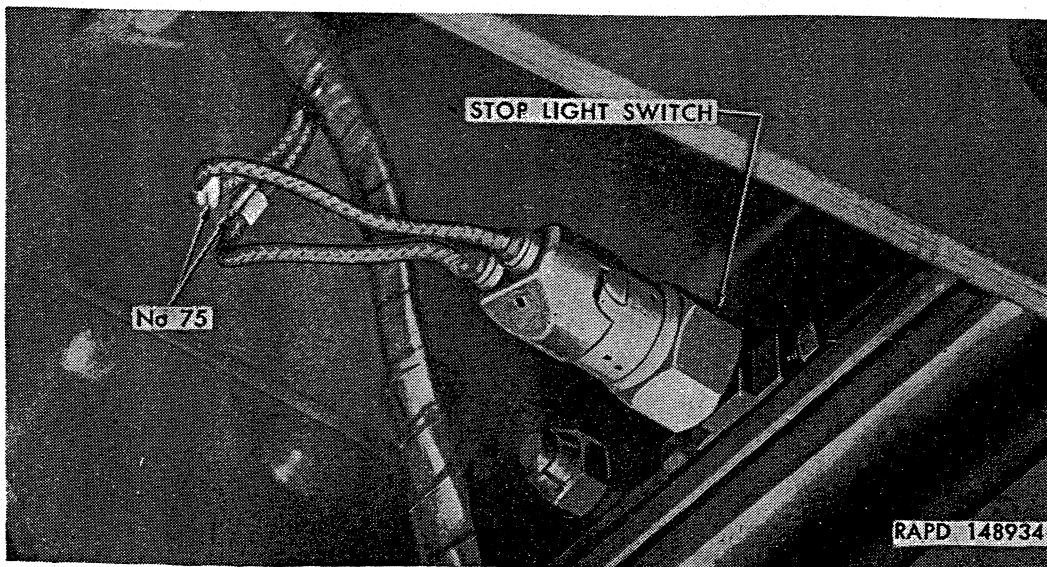

*Figure 174. Hydraulic stop light switch installed.*

- (2) Stop light switch (fig. 175) used on truck tractor M221 is air-operated to provide operation of trailer stop light when trailer brakes are applied either by the truck brake system or by the trailer brake hand control valve. Stop light switch is connected to outlet side of double check valve which is mounted inside left frame side member above forward rear axle. When brakes are applied, either by foot application of truck brakes or by hand application of trailer brakes only, air pressure closes switch contacts. With switch contacts closed, circuit is completed to blackout or service stop light, depending upon which circuit is energized through the main light switch.

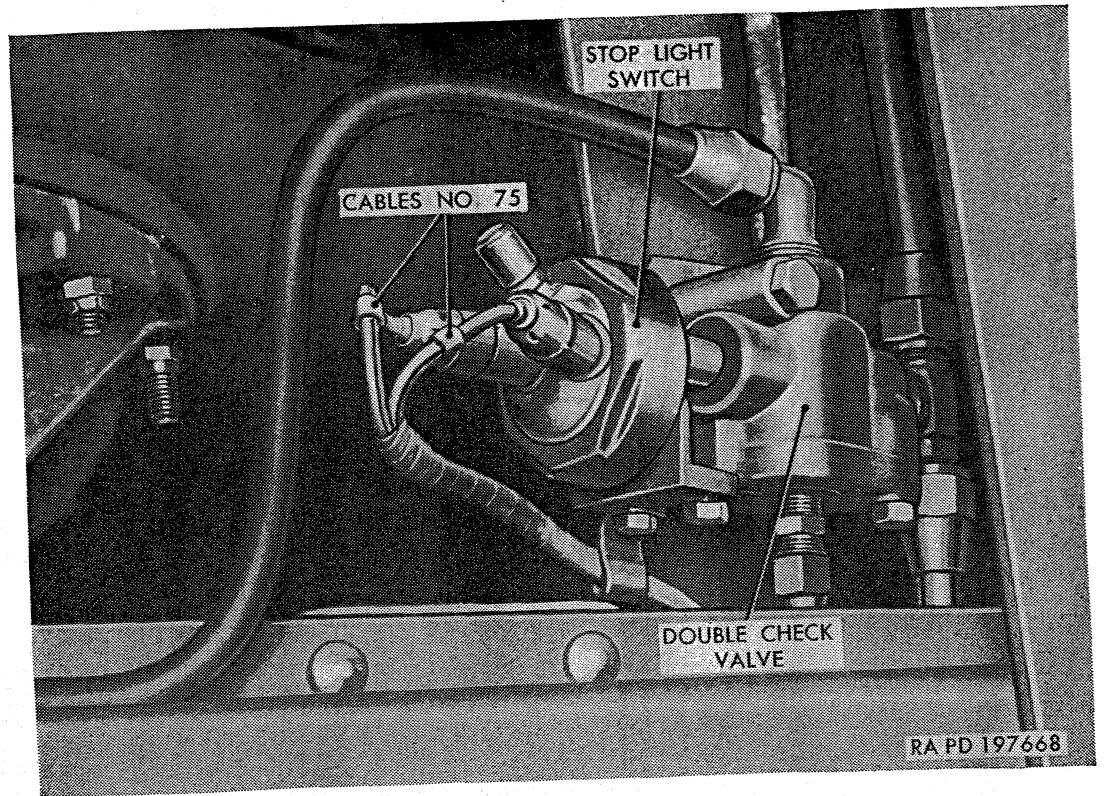

Figure 175. Air-operated stop light switch installed.

*b. Removal.*

- (1) *Hydraulic-type (all models except M221)* (fig. 174). Disconnect wiring harness cables from stop light switch terminals. Unscrew switch from tee fitting in hydraulic line. Do not apply brakes with stop light switch removed, and immediately install new switch to prevent loss of brake fluid and entrance of air into hydraulic brake lines.
- (2) *Air-type (M221 only)* (fig. 175). Disconnect wiring harness cables from stop light switch terminals. Unscrew switch from pipe nipple at side of double check valve.

*c. Installation.*

- (1) *Hydraulic-type (all models except M221)* (fig. 174). Thread switch into tee fitting in hydraulic line and tighten firmly. Connect wiring harness cables (No. 75) to switch terminals. Bleed brakes (par. 237).
- (2) *Air-type (M221 only)* (fig. 175). Thread switch onto pipe nipple at side of double check valve and tighten. Connect wiring harness cables (No. 75) to switch terminals.

## 184. Circuit Breakers

(fig. 176 or 177)

*a. Removal.* Disconnect wiring harness cable connectors from circuit breaker terminals. Remove two screws, nuts, and lockwashers attaching circuit breaker to under side of steering gear cowl bracket, and remove circuit breaker.

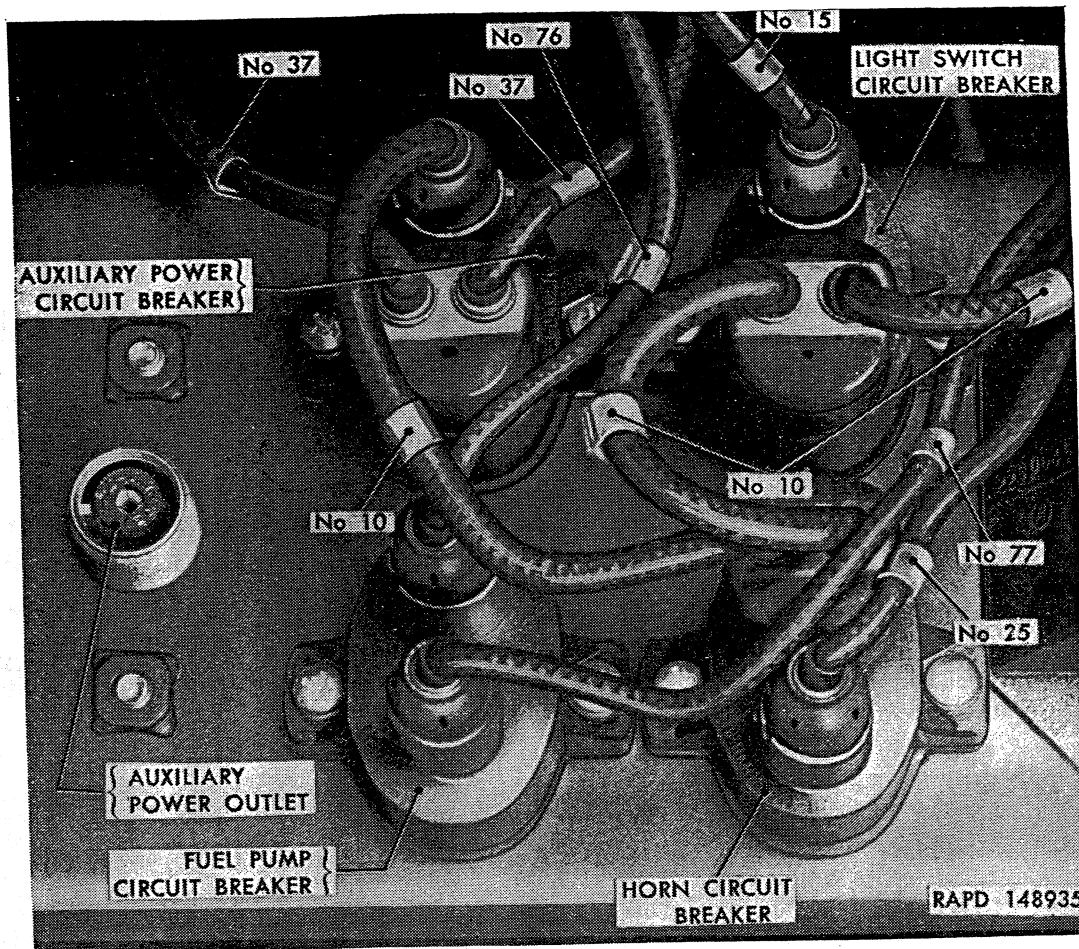

Figure 176. Circuit breakers and auxiliary power outlet installed (early M135).

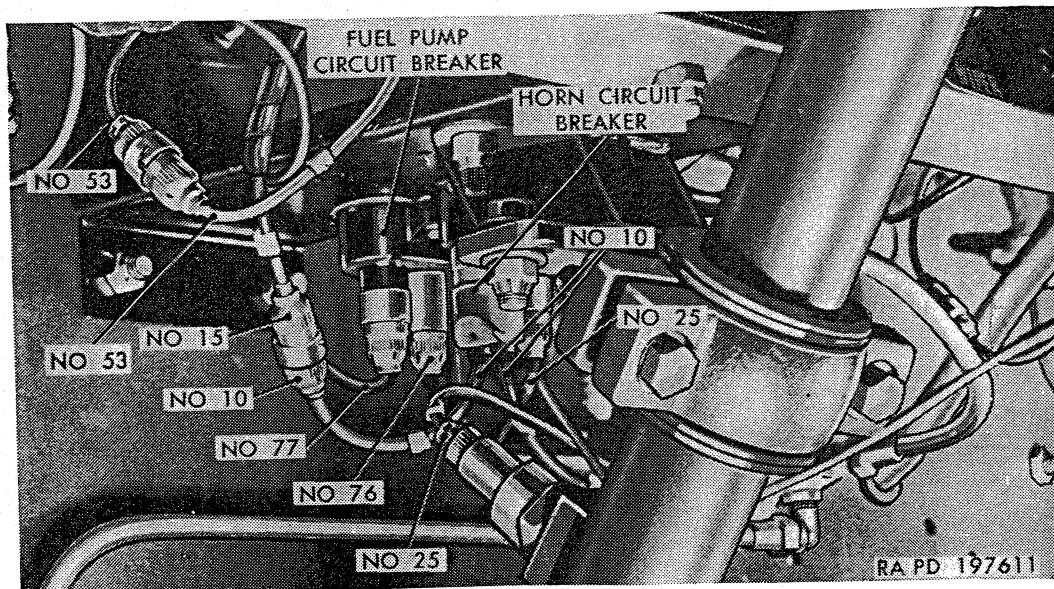

Figure 177. Horn and fuel pump circuit breakers installed (late M135 and all other models).

*b. Installation.* Position circuit breaker under steering gear cowl bracket and attach with two screws, lockwashers, and nuts. Connect wiring harness cables to circuit breaker terminals, referring to figure 167 or 168 for identification of cables connecting to each circuit breaker.

### 185. Horn and Horn Button

*a. General.* Electrically controlled, air-operated horn (fig. 178) is mounted on under side of hood reinforcement above engine. Horn is accessible with hood in raised position (par. 303*b*). Flexible air line from junction fitting on cowl connects to air inlet at horn solenoid. When electrical circuit through solenoid is completed by horn button in center of steering wheel (fig. 179), solenoid admits air pressure into the vibrating-diaphragm-type horn, causing horn to sound. Wiring connections at horn are made through bayonet-type connectors; connectors are secured in clips attached to horn projector bracket. Horn circuit is protected by a 15-amp circuit breaker (fig. 176 or 177) mounted on steering gear cowl bracket.

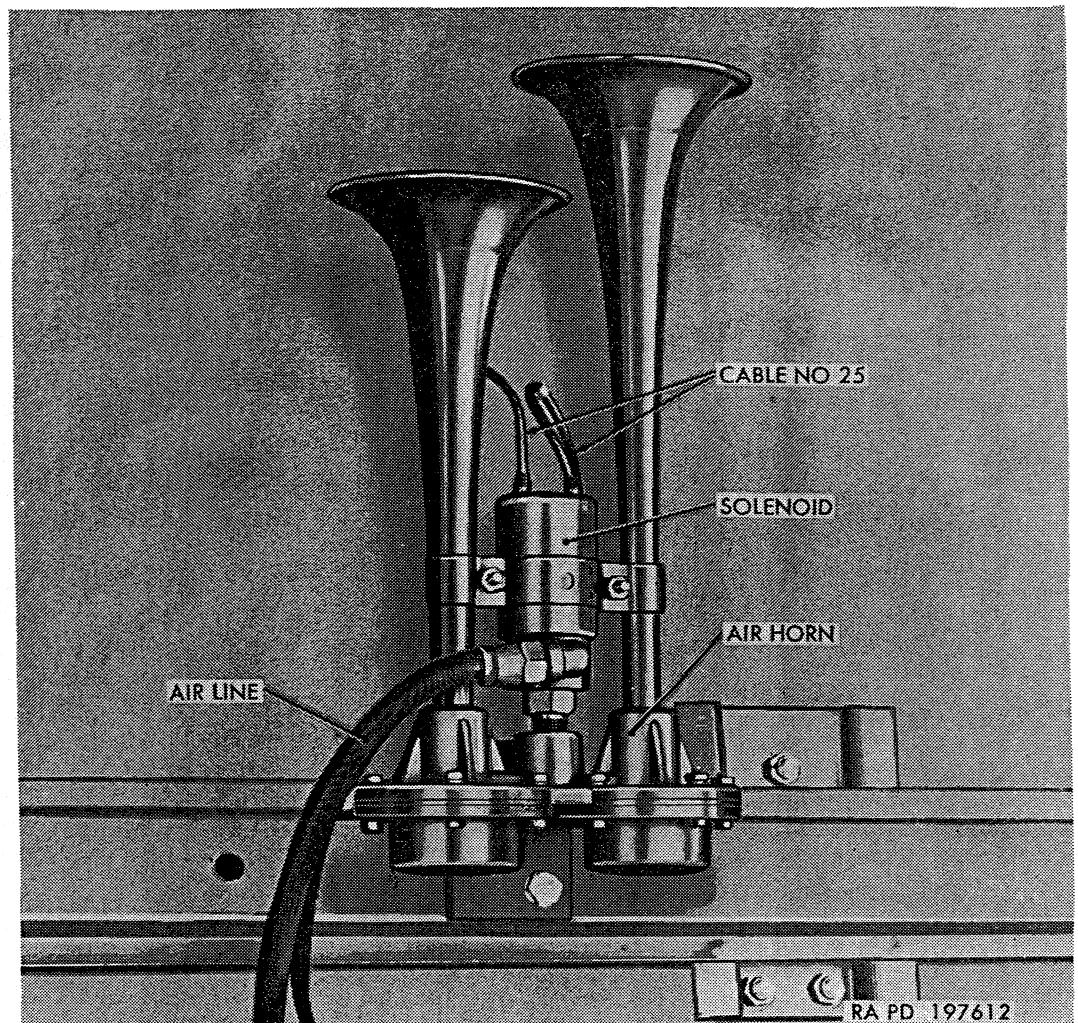

Figure 178. Horn installed.



*b. Horn Removal (fig. 178).*

- (1) Exhaust air pressure from air system. Disconnect flexible air line from horn solenoid.
- (2) Remove two cap screws and nuts attaching horn to horn bracket. Disengage cable connectors from clips on horn projector bracket and disconnect cables.

*c. Horn Installation (fig. 178).*

- (1) Connect wiring harness cables (No. 25) to horn solenoid cables; then engage connectors in clips on horn projector bracket.
- (2) Position horn at mounting bracket on hood reinforcement and attach with two  $\frac{1}{4}$ -28 x  $1\frac{1}{8}$  cap screws and  $\frac{1}{4}$ -28 nuts, securing wiring harness clip under one of the nuts. Tighten nuts and engage wiring harness in clip.
- (3) Connect flexible air line to horn solenoid inlet, tightening the connection firmly.

*d. Horn Button Removal (fig. 179).* Remove four cross-recess screws attaching horn button retaining ring to steering wheel. Remove retaining ring, horn button, and contact and spring assembly.

*e. Horn Button Installation (fig. 179).* Make sure end of contact and terminal in center of steering wheel nut are clean. Position contact and spring assembly on steering wheel nut, install horn button and retaining ring, and attach retaining ring to steering wheel with four No. 8 x  $\frac{7}{8}$  cross-recess tapping screws.

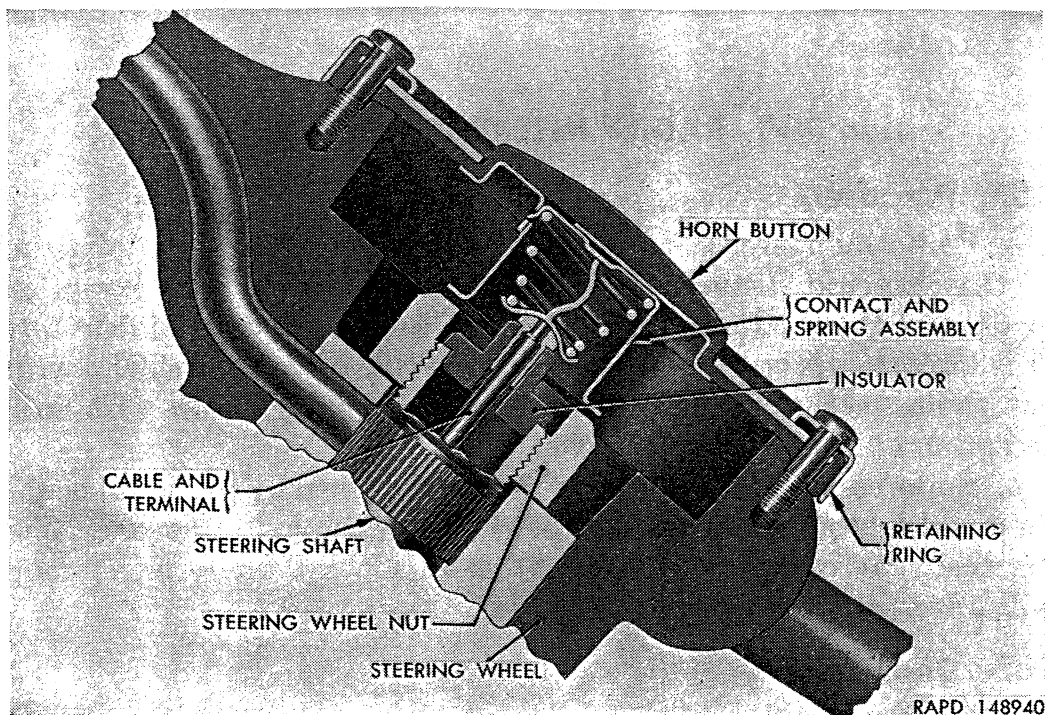

*Figure 179. Horn button and contact installed in steering wheel.*

## 186. Low Air Pressure Switch and Buzzer

(fig. 172)

*a. General.* Low air pressure switch and buzzer are safety devices designed to give a warning when pressure in air system is below a safe limit (60 psi) for brake operation. Low air pressure switch is actually an air-controlled switch in an electrical circuit, automatically controlling circuit to a warning buzzer cab. Low air pressure switch is mounted at center of cowl inside of cab, and is connected to air system at air line junction fitting on cowl. Warning buzzer is mounted on left side of cowl inside cab. Switch and buzzer circuit is fed through ignition switch and is grounded through the buzzer mounting.

*b. Low Air Pressure Switch Removal.* Disconnect cables No. 85 from terminals at top and bottom of low air pressure switch. Disconnect air line from fitting on switch body. Remove two cap screws and nuts attaching switch to cowl, and remove switch.

*c. Low Air Pressure Switch Installation.* Position low air pressure switch on cowl and attach with two  $\frac{1}{4}$ -28 x  $\frac{3}{4}$  cap screws and  $\frac{1}{4}$ -28 safety nuts. Coat air line fitting threads with plastic-type gasket cement; then connect air line to fitting on switch. Connect cables No. 85 to terminals at top and bottom of switch.

*d. Low Air Pressure Buzzer Removal.* Disconnect cable No. 85 from terminal at top of buzzer. Remove three cap screws and nuts attaching buzzer to cowl, and remove buzzer.

*e. Low Air Pressure Buzzer Installation.* Position low air pressure buzzer on cowl with terminal at top and attach with three  $\frac{1}{4}$ -28 x  $\frac{5}{8}$  cap screws and  $\frac{1}{4}$ -28 safety nuts. Connect cable No. 85 to terminal at top of buzzer.

## Section XVI. RADIO INTERFERENCE SUPPRESSION

### 187. Purpose

*a.* Radio interference suppression is the elimination or minimizing of the electrical disturbances which interfere with radio reception, or disclose the location of the vehicle to sensitive electrical detectors. It is important, therefore, that vehicles with, as well as vehicles without, radios be suppressed properly to prevent interference with radio reception of neighboring vehicles.

*b.* Suppression of these vehicles is accomplished by the use of metallic shielding, capacitors (condensers), and resistor suppressors. Wiring that may carry interfering surges to a point where interference will affect radio reception is shielded.

### 188. Description

*a. Ignition System.* Radio interference suppression in the ignition system is accomplished by a coaxial capacitor, a bypass capacitor,



and a resistor connected into the primary circuit; resistors in distributor rotor, distributor cap, and spark plugs; and shielded spark plug cables.

*b. Generating System.* The generating system is suppressed by static collector brushes at each end of generator armature shaft; a coaxial capacitor in generator output cable; two coaxial capacitors connected in series in the regulator output cable; a radio frequency choke coil in field circuit in regulator; and a shielded generator-to-regulator wiring harness.

*c. Starter.* The starter is suppressed by a capacitor connected into the starter field circuit.

*d. Fuel Pump.* The electric fuel pump is suppressed by a coaxial capacitor in input cable and a shielded capacitor-to-motor lead.

### 189. Ignition System Radio Suppression

*a. Description and Data* (fig. 180). The primary connection at the distributor terminal is equipped with a 0.25 to 0.35 mfd coaxial capacitor which is grounded to the distributor housing. A resistor is connected into the primary circuit ahead of the ignition coil. A 0.70 to 1.00 mfd bypass capacitor is connected to the ignition coil positive (+) terminal and grounded to the distributor housing. A 10,000-ohm resistor is built into the distributor rotor, and each output tower in the distributor cover is equipped with a 5,000-ohm resistor. Spark plug cables are shielded with a metallic braid molded into the cable insulation. A 10,000-ohm resistor is built into each spark plug. Spark plugs are shielded by the metal shells to which the cables connect. Capacitors and the primary circuit resistor can be replaced if defective.

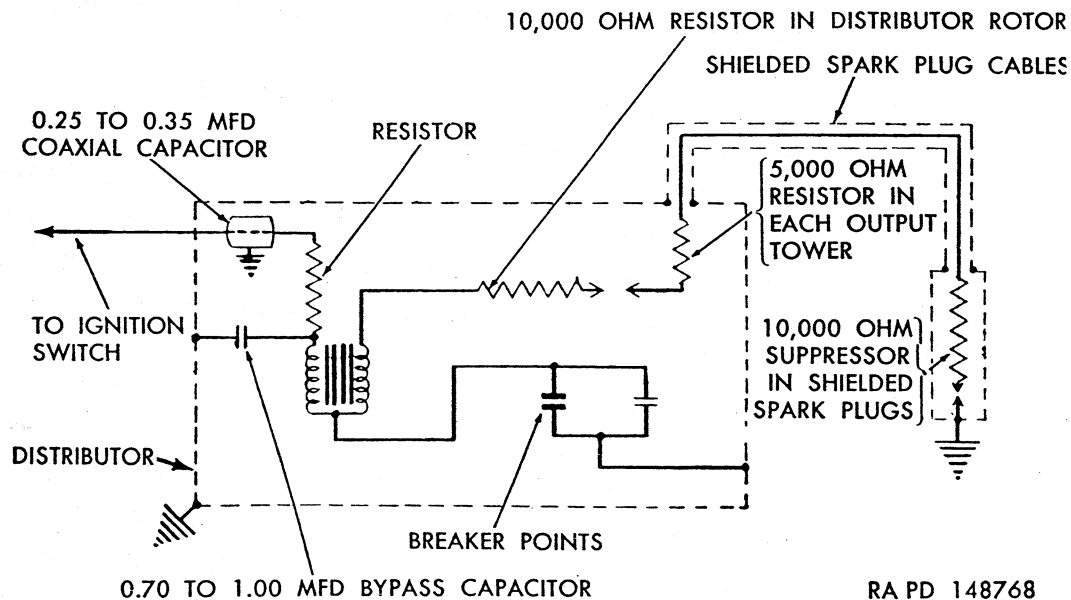

Figure 180. Schematic circuit diagram of ignition system radio suppression units.

*b. Distributor Ignition Coil Capacitor (fig. 119).*

- (1) *Removal.* Remove distributor cover. Disconnect capacitor cable terminal from ignition coil positive (+) terminal. Remove screw and clamp securing capacitor in distributor housing. Lift capacitor out of distributor housing.
- (2) *Installation.* Make sure curved spring washer is clean and in place in bottom of capacitor opening in distributor housing, with convex side up. Insert capacitor into housing and secure in place with clamp and screw and lockwasher assembly. Connect capacitor cable terminal to ignition coil positive (+) terminal. Install distributor cover, making sure gasket is in good condition and in place.

*c. Distributor Coaxial Capacitor (fig. 119).*

- (1) *Removal.* Remove distributor cover. Disconnect primary cable from coupling at distributor. Remove four screw and lockwasher assemblies attaching coupling to distributor housing. Remove coupling and gasket. Disconnect capacitor cable from resistor terminal. Withdraw capacitor from distributor housing.
- (2) *Installation.* Place curved spring washer over capacitor cable with convex side next to capacitor. Thread capacitor cable through opening in distributor housing and insert capacitor into housing. Install coupling and gasket on distributor housing and attach with four screw and lockwasher assemblies. Connect capacitor cable to resistor terminal and connect primary circuit cable to primary coupling. Install distributor cover, making sure gasket is in good condition and in place.

*d. Distributor Primary Circuit Resistor (fig. 119).*

- (1) *Removal.* Remove distributor cover. Disconnect cable from resistor terminal. Disconnect resistor cable from ignition coil positive (+) terminal. Remove two screw and lockwasher assemblies attaching resistor mounting bracket to distributor housing. Remove bracket; then lift resistor and insulator out of distributor housing.
- (2) *Installation.* Make sure curved spring washer is in place in resistor opening in distributor housing with convex side up. Position resistor and insulator in distributor housing and secure with mounting bracket and two screw and lockwasher assemblies. Connect resistor cable to ignition coil positive (+) terminal, and connect primary circuit coaxial capacitor cable to resistor terminal. Install distributor cover, making sure gasket is in good condition and in place.

## 190. Generating System Radio Suppression

a. *Description and Data* (fig. 181). A 0.09 to 0.15 mfd coaxial capacitor is connected into the generator output cable; capacitor is installed in the generator harness connector elbow and grounded to the elbow. Conductive brushes are installed in the generator, grounding each end of the armature shaft. Wiring harness leading from generator to generator-regulator is shielded with metallic braid molded into the harness insulation. Two 0.09 to 0.15 mfd coaxial capacitors are connected in series in the generator-regulator output cable and are grounded to the regulator base. A radio frequency choke coil is connected into the field circuit in the generator-regulator. Regulator base is divided into compartments for isolation of the leads.

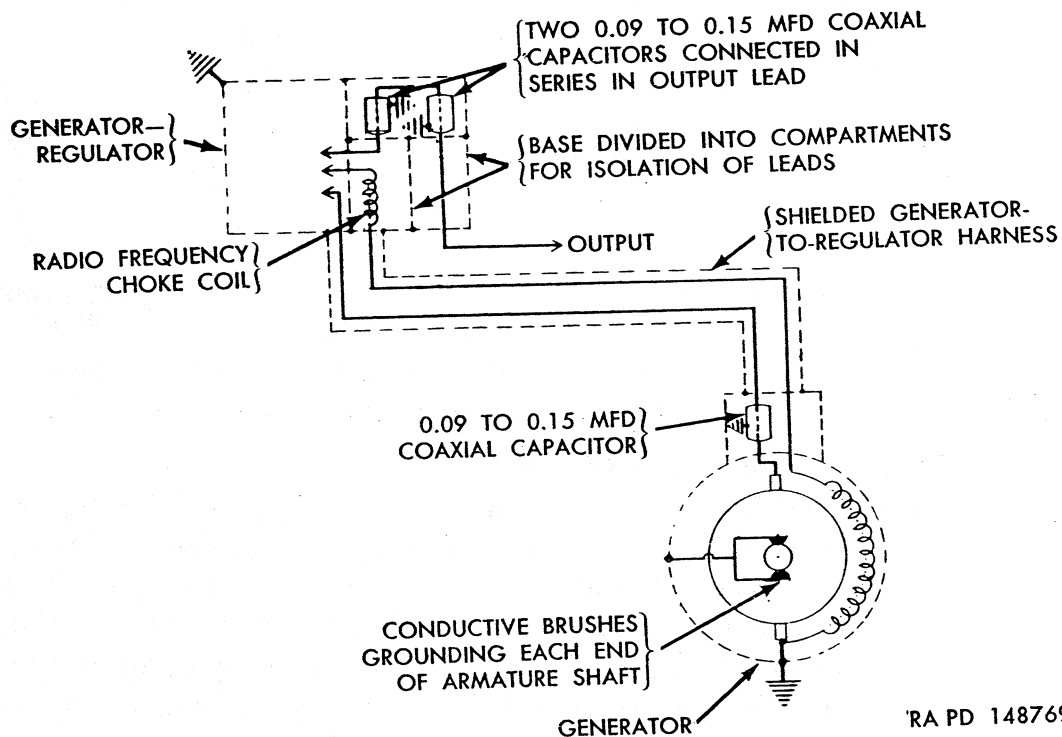

Figure 181. Schematic circuit diagram of generating system radio suppression units.

b. *Replacement*. Since replacement of the suppression units in the generator and generator-regulator requires disassembly of the generator and generator-regulator, they cannot be replaced by the using troop organization. If radio interference is originating in the generator or generator-regulator (par. 89), the complete generator or generator-regulator must be replaced (par. 155 or 156).

## 191. Starter Radio Suppression

a. *Description and Data*. Starter series field windings and insulated brushes are grounded to commutator end head through a 0.40 to 0.60 mfd capacitor (fig. 182). Capacitor (fig. 146) is mounted on commutator end head and is grounded through its mounting.

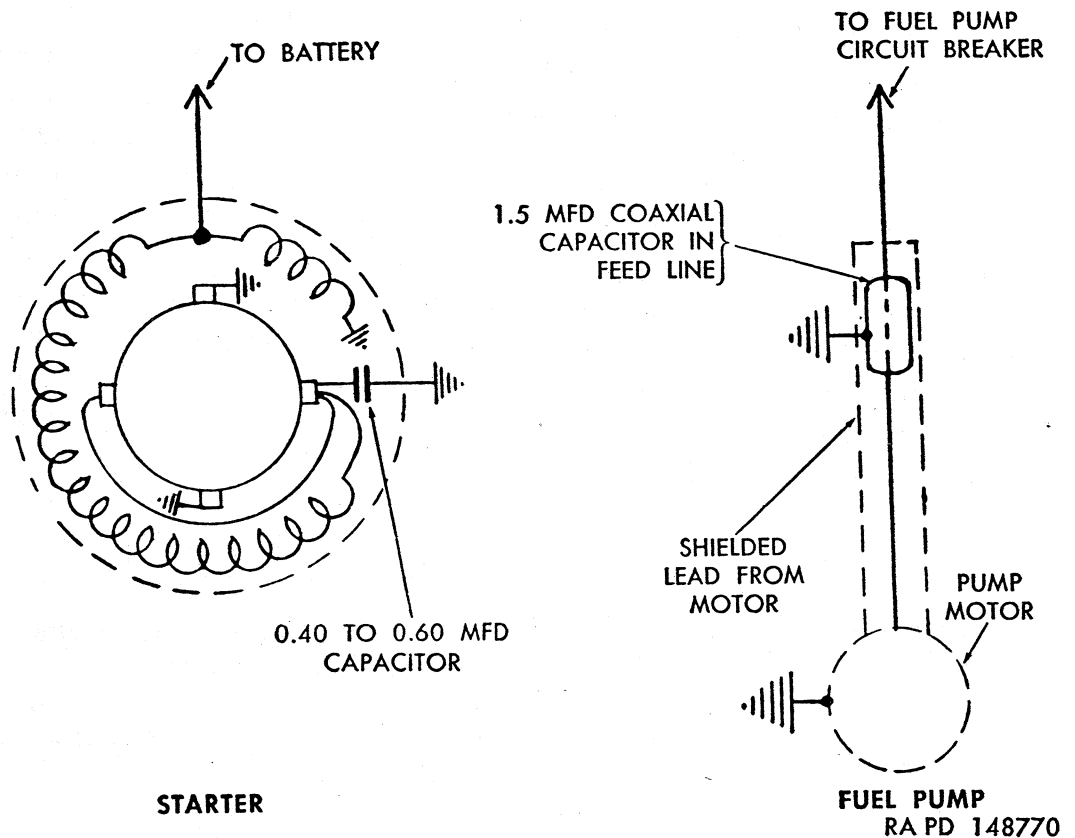

Figure 182. Schematic circuit diagram of starter and fuel pump radio suppression units.

*b. Starter Capacitor (fig. 146).*

- (1) *Removal.* Remove starter (par. 151a). Disengage two cover retaining clips from pins in starter field frame and pull end cover off starter. Disconnect capacitor cable from field and brush terminals. Remove through-bolt attaching capacitor bracket to end head. Remove capacitor and bracket, then remove capacitor from bracket. Discard capacitor.
- (2) *Installation.* Install new capacitor in capacitor bracket. Insert through-bolt through capacitor bracket and commutator end head and thread bolt into drive housing. Connect capacitor cable to starter field and brush terminals. Install starter end cover (par. 151b); then install starter (par 151c).

## 192. Fuel Pump Radio Suppression

(fig. 182)

*a. Description and Data.* A 1.5 mfd coaxial capacitor is installed in capacitor housing on top of fuel pump hanger and connected to the fuel pump input cable. Cable from capacitor to fuel pump motor is shielded with metallic braid molded into the cable insulation.

*b. Fuel Pump Capacitor Replacement.*

- (1) *Removal.* Disconnect fuel and ground cables from terminals on fuel pump capacitor housing. Remove four cap screws

and lockwashers attaching capacitor housing to fuel pump hanger. Remove capacitor housing; then disconnect capacitor cable from fuel pump motor cable terminal. Discard gasket. Remove four screws attaching capacitor terminal plate to capacitor housing and remove capacitor and terminal plate assembly. Discard capacitor and terminal plate assembly.

- (2) *Installation.* Assemble new capacitor and terminal plate assembly to capacitor housing, using new gasket, and attach with four screws. Connect capacitor cable to fuel pump motor cable terminal. Install capacitor housing on fuel pump hanger, using new gasket, and attach with four cap screws and lockwashers. Connect feed cable No. 77 to capacitor terminal and connect ground cable to other terminal on capacitor housing.

## **Section XVII. TRANSMISSION AND CONTROLS**

### **193. Description and Data**

#### *a. Description.*

- (1) This section includes organizational maintenance on transmission and controls. Reference must be made to paragraph 40 for operation of transmission by driver.
- (2) The Hydra-Matic transmission provides for automatic selection of gear ratios to supply necessary power output for operation of vehicle under all conditions. Transmission is attached directly to engine flywheel housing as shown in figure 183. Rear of transmission is supported by frame cross member on two flexible cushioned mountings. Transmission mountings serve also as power plant rear supports.
- (3) Engine flywheel housing incloses a fluid coupling used to transmit power to transmission. Fluid coupling eliminates need for a manually operated clutch. Fluid coupling is combined with hydraulically controlled planetary gear units to provide four forward and one reverse speed in either of two driving ranges, namely: HIGH RANGE and LOW RANGE. Fluid coupling is composed of two torus members (fig. 184), inclosed in an oil-filled chamber formed by flywheel and torus cover. Engine power is transmitted from flywheel through torus cover which drives front planetary unit, and power input to driving torus in fluid coupling is through front planetary unit. Driven torus is mounted on transmission main shaft which drives rear planetary unit.
- (4) Front and rear planetary units are similar in construction, each having a band designed to be applied to or released from

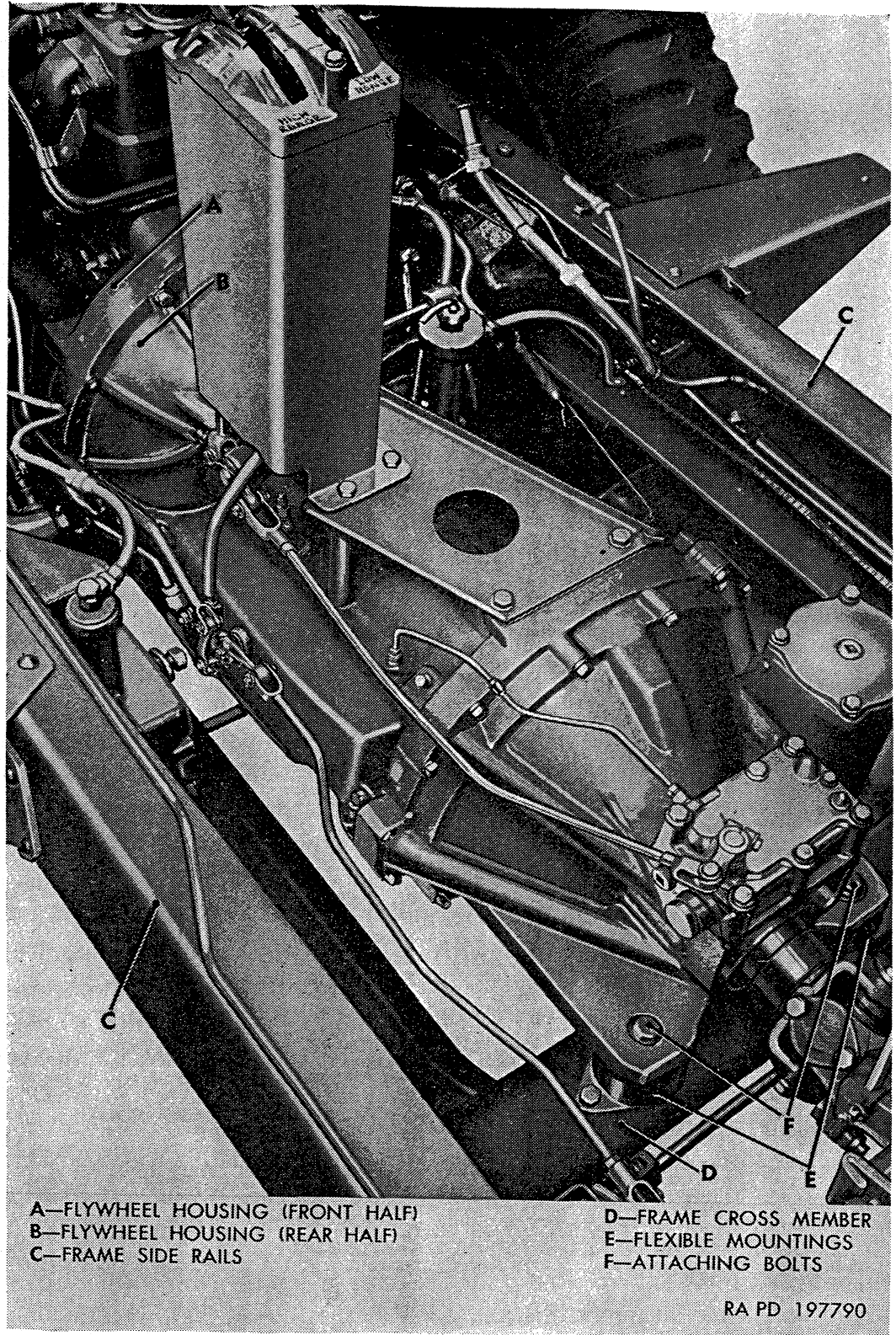
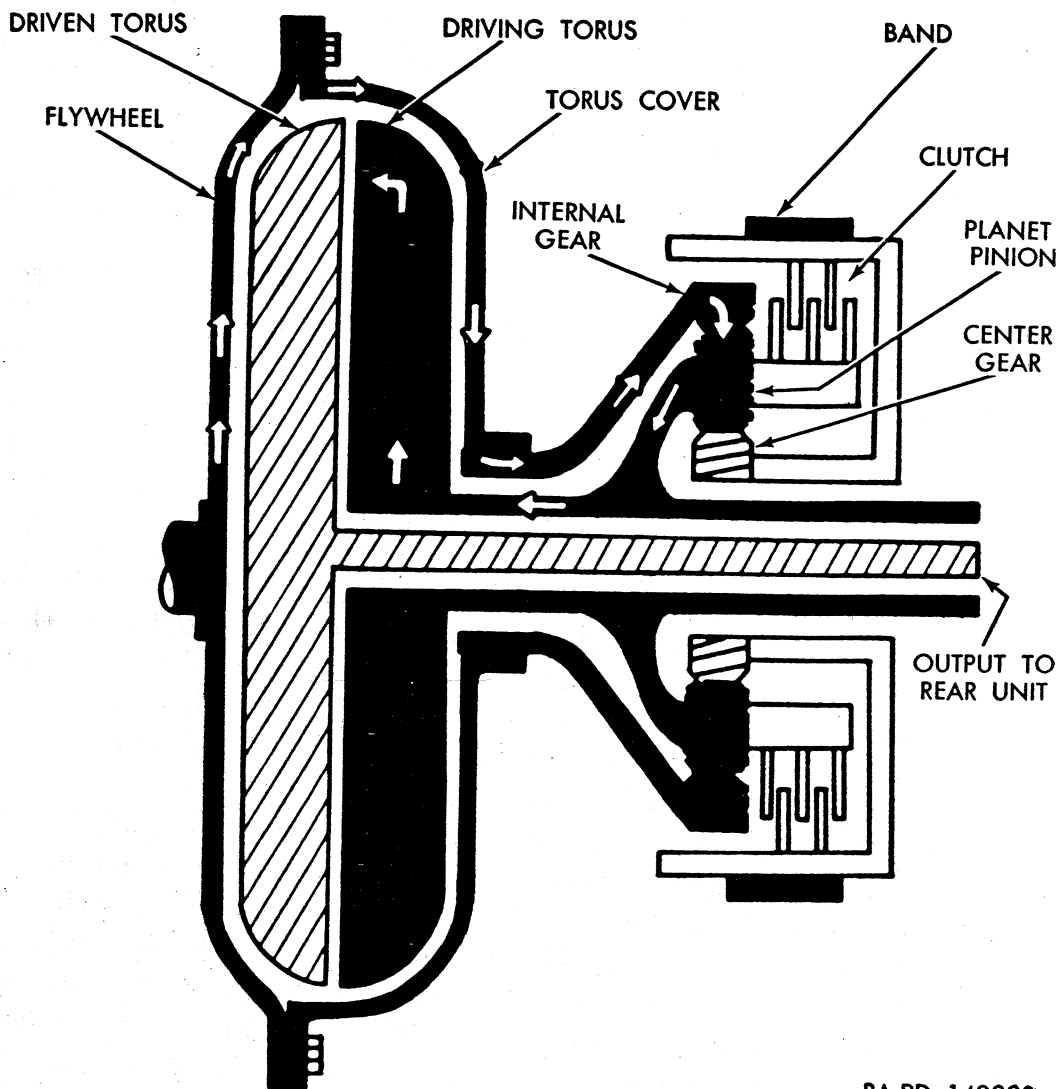

Figure 183. Transmission installed.





RA PD 149223

Figure 184. Schematic view of fluid coupling and front planetary unit.

its respective drum. When front unit band is applied to drum, center gear is held and unit is said to be in reduction. When rear unit band is applied, internal gear is held and rear unit is in reduction. A multiple disk clutch is incorporated in each planetary unit, and when clutch is engaged, unit is in direct drive. Bands and clutches are actuated by springs and hydraulically operated servos.

- (5) The two-speed reduction unit located in rear section of transmission is planetary-type, incorporating a cone-type clutch applied by a piston to hold internal gear when unit is in LOW RANGE or reduction. A multiple disk-type clutch, also applied by a piston, is used for placing reduction unit in HIGH RANGE or direct drive. Choice of ranges is made by driver (par. 40) through use of manually operated control lever.

- (6) Transmission oil temperature is controlled by an oil cooler located in bottom of transmission oil pan. Cooler is connected to engine cooling system and coolant from engine is circulated through cooler.

*b. Data.*

Transmission model	-----		302M
Ratios:			
	<i>Gear</i>	<i>High range</i>	<i>Low range</i>
1st speed	-----	4. 08:1	----- 15. 67:1
2d speed	-----	2. 63:1	----- 10. 05:1
3d speed	-----	1. 55:1	----- 5. 95:1
4th speed	-----	1. 00:1	----- 3. 82:1
Reverse	-----	4. 54:1	----- 17. 35:1
Lubricant capacity	-----		16 qts. approx.

**194. Checking, Draining, and Filling**

*a. Oil Filler Tube.* On some early vehicles, there is no oil screen installed in the oil filler tube. No modification is needed on these vehicles, as there is no restriction encountered when adding or refilling oil in transmission. On other early vehicles, an oil screen was installed in oil filler tube. On these vehicles, modifications as described in MWO ORD G749-W4 must be accomplished.

*b. Checking Oil Level.* Refer to lubrication chart (par. 69) for type of oil and lubrication intervals. Transmission oil level indicator (dipstick), located in the oil filler tube, has two level marks: COLD FULL—lower mark and HOT FULL—upper mark (fig. 185). COLD FULL mark is used for checking oil level when vehicle has not been run for an extended period. HOT FULL mark is used when checking oil level after vehicle has been run and engine and transmission are warmed to normal operating temperature. Transmission oil level must be checked in the following manner if a correct reading on indicator is to be obtained.

*Note.* Transmission does not burn or use oil as an engine does. If oil level lowers appreciably from one checking period to another, transmission is leaking oil. Refer to paragraph 195 for procedures used when making oil leakage check. If oil level is higher than HOT FULL mark on indicator, refer to paragraph 196 for procedures used when making coolant leakage check.

**Caution:** Transmission oil level is checked with engine running and with transmission in F-1 HIGH RANGE. Engine must not be run above idling speed, and parking brake must be firmly applied. As a further precaution, personnel should not be in front of vehicle while oil level check is being made.

- (1) *Transmission cold.* When engine has not been run for an extended period, apply parking brake and start engine. Move transmission control lever into F-1 HIGH RANGE position and run engine at idling speed for 3 to 5 minutes. Lift floor plate to gain access to transmission oil level indicator; then

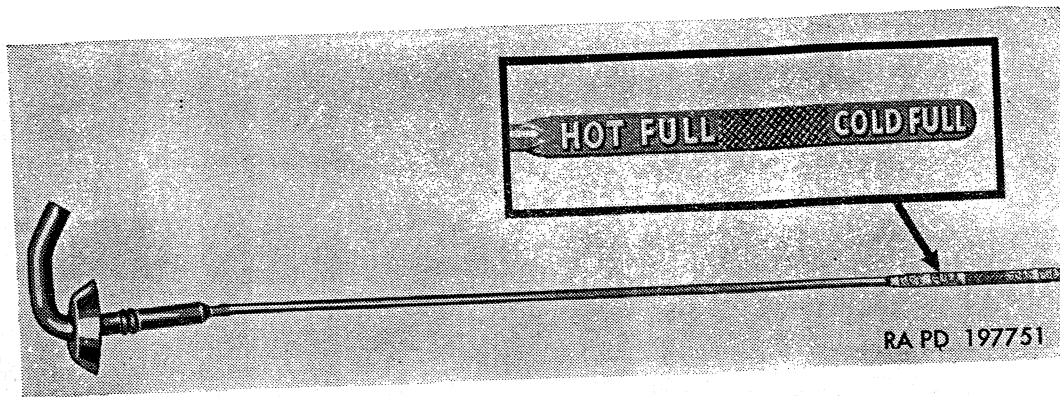

Figure 185. Transmission oil level indicator removed.

clean all dirt from area around indicator. With engine still running, withdraw indicator, wipe off, and reinsert. Again withdraw indicator. Oil level reading should be at approximately the COLD FULL mark on indicator (fig. 185).

- (2) *Transmission hot.* When vehicle has been run and engine and transmission are warmed to normal operating temperature, apply parking brake and start engine. Move transmission control lever into F-1 HIGH RANGE position and run engine at idling speed for 3 to 5 minutes. Lift floor plate to gain access to transmission level indicator; then clean all dirt from area around indicator. With engine still running, withdraw indicator, wipe off, and reinsert. Again withdraw indicator. Oil level reading should be approximately at HOT FULL mark on indicator (fig. 185).

*c. Replenishing Oil.* With transmission control lever in N (neutral) position and parking brake lever applied, start engine. Move transmission control lever into F-1 HIGH RANGE position. Clean all dirt from areas around filler cap; then remove filler cap and level indicator. Add sufficient oil to bring oil level up to reading on indicator (fig. 185), depending upon whether transmission is COLD or HOT as described in *b* above. Install filler cap and indicator; then recheck oil level.

**Caution:** Do not overfill transmission. An excessive amount of oil will cause spinning drums to aerate oil, causing heating and foaming of oil which in turn will cause erratic shifting and oil leakage.

*d. Draining Transmission Oil* (fig. 186).

- (1) *Drain fluid coupling.* Remove eight cap screws and lock-washers attaching flywheel housing cover to flywheel housing; then remove cover. Turn engine flywheel until torus cover drain plug is at lowest point; then remove torus cover drain plug. Discard plug gasket.
- (2) *Drain oil pan.* Remove transmission oil pan drain plug from bottom of oil pan. Discard plug gasket.

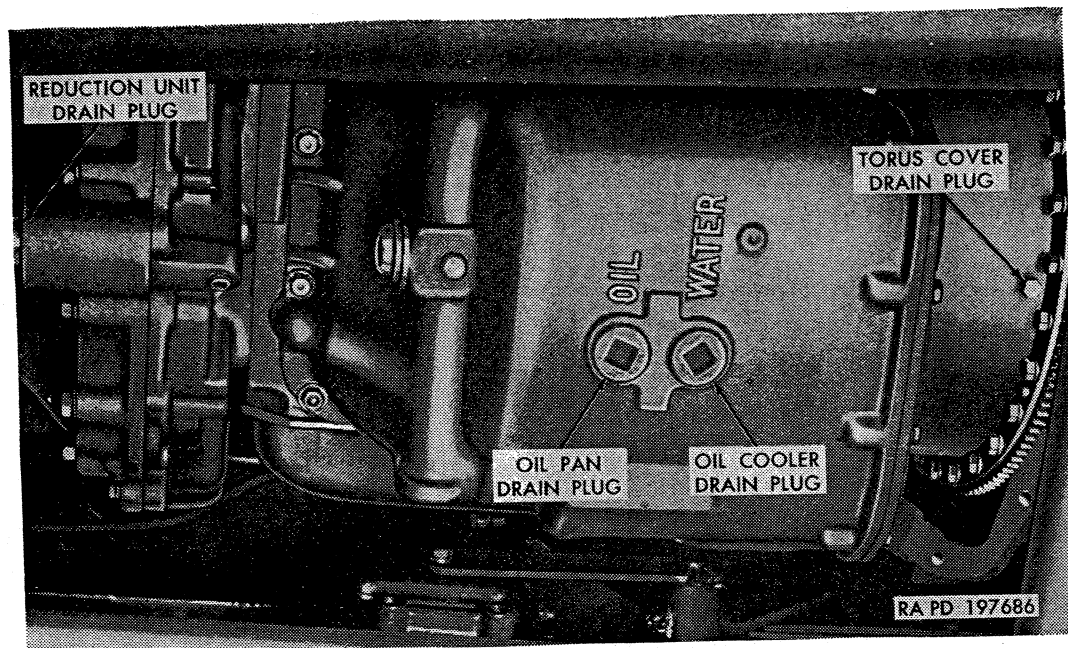

Figure 186. Transmission oil and water drain plugs installed—flywheel housing cover removed.

- (3) *Drain reduction case.* Remove reduction unit drain plug from rear of transmission. Discard plug gasket.
  - (4) *Install drain plugs.* After transmission and fluid coupling are thoroughly drained, apply a thin coating of plastic-type gasket cement to threads of torus cover drain plug and install plug in torus cover. Tighten plug to 15 to 18 pound-feet torque. Install flywheel housing cover on flywheel housing, attaching with eight  $\frac{3}{8}$ -16 x 1 cap screws and  $\frac{3}{8}$ -inch lockwashers. Tighten cap screws. Install drain plugs and new gaskets in bottom of transmission oil pan and at rear of transmission in reduction case. Tighten plugs to 35 to 45 pound-feet torque.
- e. *Refilling Transmission.*
- (1) With transmission and fluid coupling thoroughly drained and drain plugs installed (*d* above), lift floor plate to gain access to transmission oil level indicator and filler cap. Clean all dirt from area around filler cap; then remove filler cap and level indicator.
  - (2) Pour 12 quarts of engine lubricating oil (OE-10) into transmission case (A, fig. 187), or when temperature of  $+10^{\circ}$  F. or below is expected, use subzero engine lubricating oil (OES). Be sure container and spout or funnel used to pour oil are clean. Install filler cap and level indicator in transmission oil filler tube.
  - (3) With transmission control level in N (neutral) position and parking brake lever applied, start engine. Move control

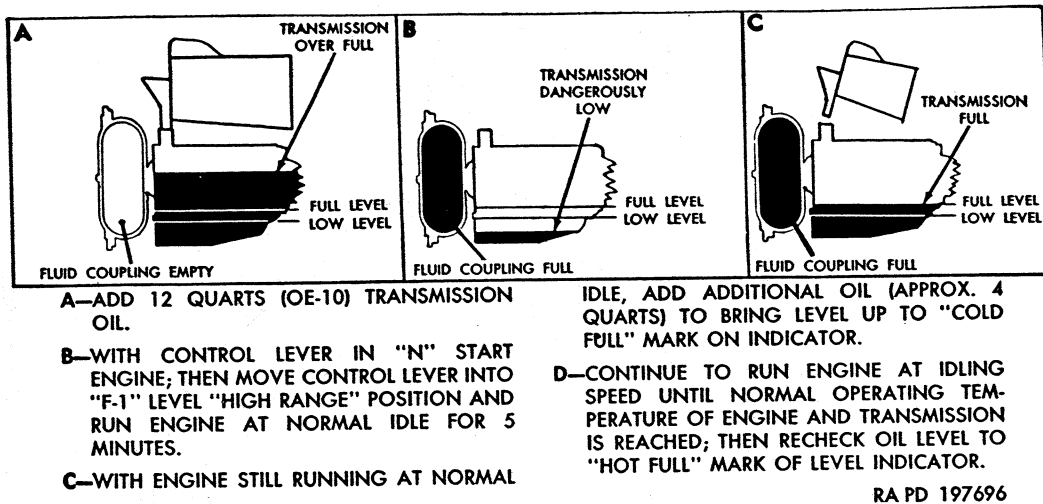

Figure 187. Typical method of filling transmission.

- lever into F-1 HIGH RANGE position and run engine at idling speed for approximately 5 minutes (B, fig. 187).
- (4) Remove filler cap and level indicator from filler tube; then add sufficient additional oil (approx. 4 qts.) to bring oil level up to COLD FULL mark on indicator (C, fig. 187). Install filler cap and level indicator in oil filler tube.

**Caution:** Oil capacity of Hydra-Matic transmission is approximately 16 quarts. However, correct oil level is determined by level reading on indicator, not by quantity of oil added. Do not overfill transmission. An excessive amount of oil will cause spinning drum to aerate oil, causing heating and foaming, which in turn will cause erratic shifting and oil leakage.

- (5) Continue to run engine at idling speed until normal operating temperature of engine and transmission is reached; then recheck oil level as described in *b* (2) above to HOT FULL mark on level indicator.

## 195. Oil Leakage Checks

*a. General.* The Hydra-Matic transmission does not burn or use oil as an engine does. Consequently, if transmission oil level is found to be low at frequent checking periods, cause is due to leakage. Source of leakage must be determined and condition corrected to avoid serious damage to transmission.

*b. At Flywheel and Torus Cover* (fig. 188).

- (1) Remove eight cap screws and lockwashers attaching flywheel housing cover to flywheel housing; then remove cover.
- (2) Using dry-cleaning solvent or volatile mineral spirits, wash flywheel and torus cover thoroughly; then dry completely.
- (3) Spread a clean piece of white or brown paper under flywheel and torus cover.

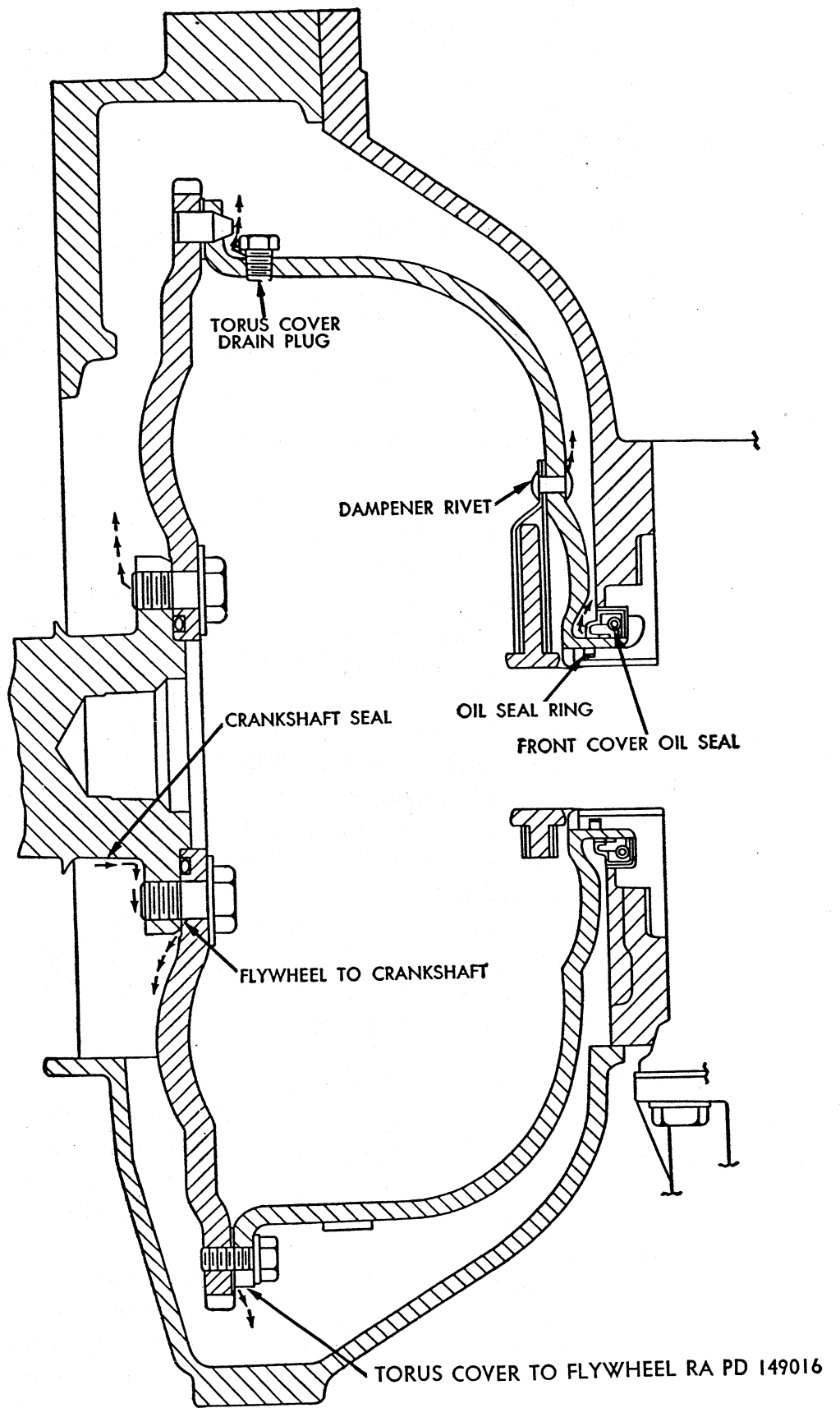

Figure 188. Location of possible oil leaks.



- (4) With transmission control lever in N (neutral) position, start engine and run at a speed of 700 rpm for several minutes, or until spray marks appear on paper; then stop engine.
- (5) Check for leaks in line with spray marks on paper; also examine flywheel and torus cover carefully.
- (6) If oil is streaked along front face of flywheel, leakage is between flywheel and crankshaft. If oil is streaked along torus cover, leakage is occurring between torus cover neck and oil seal, between front oil pump cover and transmission case, at torus cover dampener rivets, or from front pump cover to body bolts.
- (7) If flywheel or torus cover are not streaked with oil, leakage may be at joint between flywheel and torus cover.
- (8) If evidence of leakage is found at any point described in (5, 6, and 7) above, notify ordnance maintenance personnel.
- (9) If leakage is found at torus cover drain plug, tighten plug. If leak continues, remove drain plug and drain fluid coupling. Apply a thin coating of gasket cement to threads of plug; then install plug in torus cover. Tighten plug to 15 to 18 pound-feet torque. Refill transmission to proper level (par. 194e).

*c. At Transmission Oil Pan.*

- (1) Check for loose oil pan to transmission case attaching cap screws and nuts. If found loose, tighten cap screws and nuts to 10 to 13 pound-feet torque. If leakage at this point continues, cause may be defective oil-pan-to-transmission-case gasket. Replace gasket as in (a) through (k) below.
- (a) Remove drain plug at bottom of transmission oil pan marked WATER and drain water from transmission oil cooler in oil pan. Refer to figure 186.
- (b) Remove magnetic oil pan drain plug from transmission oil pan (plug is marked OIL) and drain oil from transmission oil pan into a clean receptacle. Refer to figure 186.
- (c) Unscrew oil cooler line nuts at both sides of transmission oil pan; then pull lines free from transmission.
- (d) Remove 10 cap screws, 2 stud nuts, and 12 copper washers attaching oil pan to transmission case; then remove oil pan and pan-to-case gasket from case. Discard gasket and washers.
- (e) Scrape all dirt or old gasket material from transmission case and oil pan mating surfaces; then position new oil-pan-to-transmission-case gasket on transmission oil pan.
- (f) Position oil pan on transmission case, making sure front oil pump intake tube is properly positioned.

- (g) Install ten  $\frac{5}{16}$ -18 x  $\frac{3}{4}$  cap screws, two  $\frac{7}{16}$ -24 stud nuts, and 12 new  $\frac{11}{32}$ -inch copper washers which attach oil pan to transmission case. Tighten cap screws to 15 to 18 pound-feet torque and stud nuts to 10 to 13 pound-feet torque.
  - (h) Position oil cooler lines on each side of transmission oil pan; then tighten cooler line nuts.
  - (i) Install oil pan magnetic drain plug in transmission oil pan. Tighten plug to 35 to 45 pound-feet torque.
  - (j) Install water drain plug and tighten to 35 to 45 pound-feet torque; then refill engine cooling system (par. 142a).
  - (k) Replace transmission oil previously removed; then check torque; then refill engine cooling system (par. 194c).
- (2) If leakage is found at transmission oil pan drain plug, check to see if plug is loose. Tighten plug to 35 to 45 pound-feet torque. If leakage continues, remove drain plug and gasket from oil pan. Discard gasket. Install new gasket on drain plug; then install plug in oil pan. Tighten plug to 35 to 45 pound-feet torque.
- d. *At Transmission Side Cover.*
- (1) Check oil pressure test plug, pressure regulator plug, and external oil line fittings for looseness. Tighten loose parts as necessary.
  - (2) Check for loose transmission-side-cover-to-case attaching cap screws. If loose, tighten cap screws to 12 to 15 pound-feet torque. If leakage continues at this point, notify ordnance maintenance personnel.
- e. *Between Transmission Case and Reduction Unit Case.* If leakage is noticed from between transmission case and reduction unit case, notify ordnance maintenance personnel.
- f. *At Bottom of Reduction Unit Case.*
- (1) If leakage is from reduction unit drain plug, check to see if plug is loose. Tighten plug to 35 to 45 pound-feet torque. If leakage continues, remove plug from case and install new gasket on plug. Install plug in case and tighten to 35 to 45 pound-feet torque.
  - (2) If leakage is evident between rear-bearing retainer and reduction unit case gasket area, notify ordnance maintenance personnel.
- g. *At Rear of Reduction Unit.* If leakage is evident at rear of reduction unit, report condition to ordnance maintenance personnel.
- h. *Around Reduction Unit Control Valve Assembly.*
- (1) If leakage is occurring from reduction unit pressure regulator valve plug, tighten plug to 35 to 45 pound-feet torque. If leakage continues, remove plug from reduction unit control valve body and discard the fiber washer. Install new fiber

- washer on plug; then install plug in control valve body. Tighten plug to 35 to 45 pound-feet torque.
- (2) If leakage is found at manual control valve stop pipe plug, tighten plug to 25 to 30 pound-feet torque.
  - (3) If reduction unit control valve assembly or control lever seals are found to be defective, causing leakage, notify ordnance maintenance personnel.

## 196. Water Leakage Checks

*a. Internal Leaks.* If transmission oil level is found to be high at frequent checking periods, cause is probably due to internal water leaks from cooler core or cooler core connections. Check for internal water leakage by draining a small quantity of oil from transmission. Examine drained oil for presence of water. If evidence of internal water leakage is found, report to ordnance maintenance personnel. If no evidence of internal water leakage is found, refill transmission as directed (par. 194e).

*b. At Oil Cooler Cover.* If water leakage is found at cooler core cover, cause may be loose cover-to-transmission-oil-pan attaching cap screws, or defective cover-to-oil-pan gasket. Tighten cover-to-oil-pan cap screws to 15 to 18 pound-feet torque. If leakage continues, remove eight cover-to-oil-pan attaching cap screws and lockwashers; then remove cover and cover-to-oil-pan gasket. Discard gasket. Scrape any accumulation of dirt or old gasket material from cover and oil pan mating surfaces. Position new gasket and cover on oil pan; then attach cover to oil pan with eight  $\frac{5}{16}$ -18 x  $\frac{7}{8}$  cap screws and  $\frac{5}{16}$ -inch lockwashers. Tighten cap screws to 15 to 18 pound-feet torque.

*c. At External Water Cooler Hose Connections.* Tighten all hose connections.

*d. At Oil Pan Water Drain Plug.* Tighten water drain plug to 35 to 45 pound-feet torque. If leakage continues, remove plug from oil pan and discard gasket. Install new gasket on drain plug; then install plug in oil pan. Tighten plug to 35 to 45 pound-feet torque. Refill engine cooling system (par. 142a).

## 197. Operation Tests

*a. General.* Approximately 70 percent of Hydra-Matic transmission troubles can be corrected by external adjustments without removing transmission from vehicle. While many of the corrections of troubles are beyond the scope of the using organization, following tests should be made to determine necessity for replacement of transmission. It should be kept in mind that directions should be followed carefully and that a complete diagnosis be made. Perform all tests; if any are omitted, an incorrect diagnosis will be the result. Perform operation tests at intervals indicated in table IV.

*b. Purpose.* Various tests and checks are made with engine running under simulated operating conditions and/or actual road testing vehicle, to determine malfunctions in transmission. From results of checks or tests some parts of transmission can be replaced or adjusted without removing transmission from vehicle.

*c. Preliminary Checking Procedures.* Certain factors directly affecting operation of Hydra-Matic transmission must be checked before making operation tests. An accurate check of the following procedures will assist in rapid location and correction of transmission malfunctions. After these preliminary checks are made, make road tests as described in paragraph 199.

(1) *Transmission oil check.*

(a) *Oil level.* Make oil check (par. 194b). If oil level is too low, make oil leakage check (par. 195). If oil level is too high, make water leakage check (par. 196) or refer to CAUTION regarding overfilling (par. 194e(4)).

(b) *Oil pressure.* Make oil pressure test (par. 198).

(2) *Engine performance.* Engine performance has a very definite influence on transmission performance. Engine idle speed (375 rpm) and idle mixture adjustments must be accomplished as described in paragraph 127b. If engine idle adjustment is changed, transmission throttle linkage must be readjusted (par. 202b) before attempting operation tests.

(3) *Transmission control linkage.* Check transmission throttle and manual control linkage for free action and correct adjustment. Adjust linkage if necessary (par. 202).

(4) *Front band adjustment.* Check transmission front band adjustment and adjust if necessary (par. 202).

## 198. Oil Pressure Tests

*a. Truck Standing.*

- (1) Lift floor plate to gain access to pressure takeoff pipe plug, located on top of transmission case between front and rear band adjusting screws; then remove pressure takeoff pipe plug.
- (2) Install adapter of pressure checking gage B7950330 (fig. 189) in hole in transmission case from which pipe plug was removed, leaving gage seated on floor of truck cab.
- (3) Remove access screw from top of engine distributor cover; then thread adapter (fig. 190) into hole in cover from which access screw was removed.
- (4) Connect electric tachometer to adapter and ground (fig. 190).
- (5) Start engine and run for several minutes until engine and transmission are warmed to operating temperature.

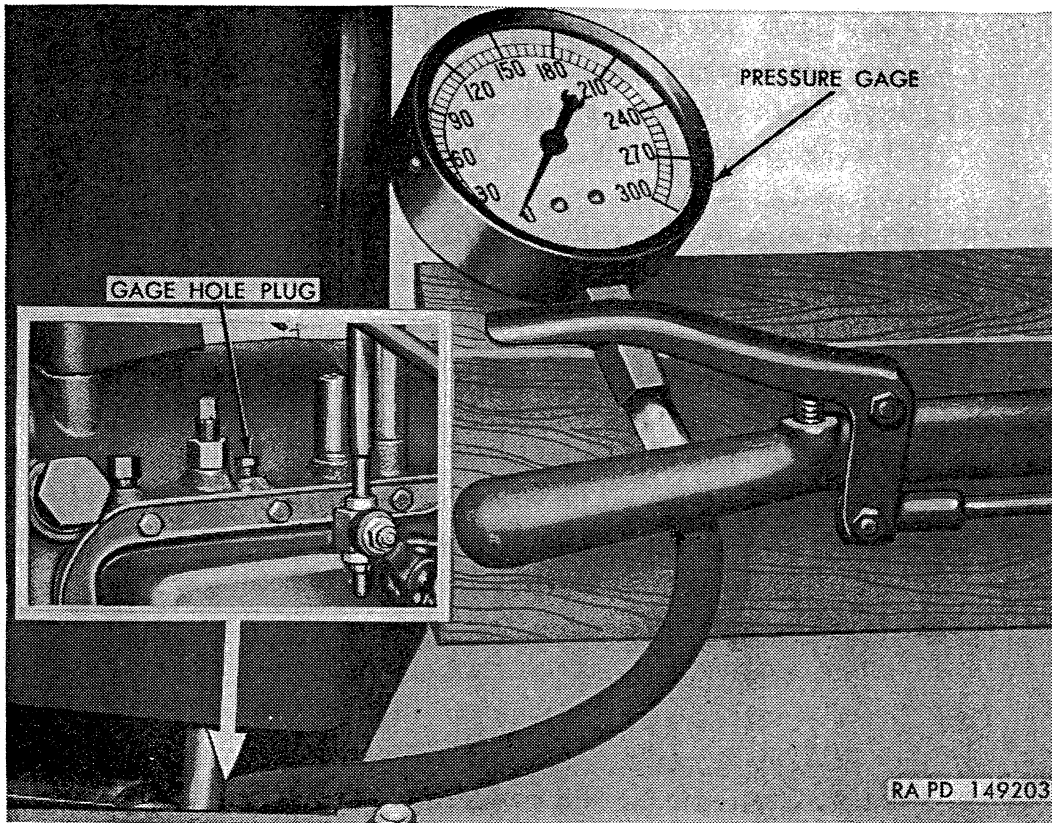

Figure 189. Use of gage B7950330 when making oil pressure test.

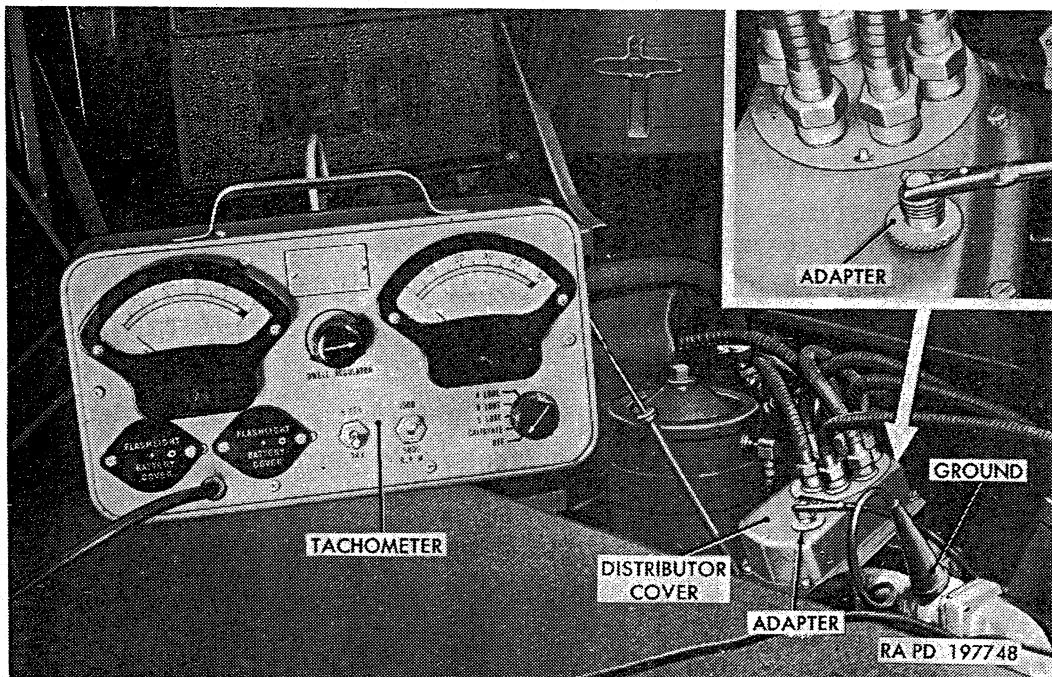

Figure 190. Using electric tachometer to check engine rpm.

- (6) With truck standing and with parking and foot brakes applied, accelerate engine to 1,000 rpm reading on tachometer.
- (7) Move transmission control lever into all four HIGH RANGE positions (N, F-1, F-2, and R), and into N (neutral) in LOW RANGE position.
- (8) With transmission oil warm, oil pressure should be 95 to 110 psi in all positions except reverse, and 180 to 220 psi in reverse.
  - (a) If oil pressure checked too low during test, check for low transmission oil level (par. 194b). If oil level is at HOT FULL mark on level indicator, notify ordnance maintenance personnel. On some early vehicles, if procedures described in MWO ORD G749-W5 are accomplished, low oil pressure condition may be corrected.
  - (b) If oil pressure checked too high during test, notify ordnance maintenance personnel.
- (9) Electric tachometer (fig. 190) and oil pressure checking gage B7950330 (fig. 189) should remain connected during road test (par. 199) and operating oil pressure test (b below).

*b. Truck Moving Forward.* Use electric tachometer and oil pressure checking gage B7950330 (fig. 189) during road test (par. 199) and take oil pressure reading after each upshift. Pressure will be less as instant shift is made but should return to original reading after shift is completed. If pressure loss or slippage is noted, check symptoms and causes in table VI.

*c. Reduction Unit Oil Pump Pressure Test.* During road test (par. 199), make reduction unit oil pump pressure test as in (1), (2), and (3) below.

- (1) With pressure checking gage B7950330 (fig. 189) installed, drive truck forward at speed of approximately 30 mph; then move transmission control lever into N (neutral) HIGH RANGE position.
- (2) Turn off ignition switch, and note reading on pressure checking gage with vehicle coasting. Pressure should be between 95 and 110 psi.
- (3) If pressure is lower than 95 psi, probable cause is faulty reduction unit oil pump. Notify ordnance maintenance personnel.

**Caution:** When making reduction unit oil pump pressure test, do not move transmission control lever from N (neutral) position into a driving range position until vehicle has been brought to a complete stop.



## 199. Road Test

*a. Purpose.* An actual road test should be made under various operating conditions to check for transmission malfunctions. Before making road test, accomplish preliminary checking procedures and tests (pars. 197 and 198). Preliminary checks and tests may disclose source of transmission trouble. Make certain causes disclosed by preliminary procedures are remedied before road testing vehicle.

### *b. Upshift and Downshift Checks.*

- (1) Upshift and downshift automatic shift patterns should be made while road testing transmission. Perform tests in sequence listed in table X. Make each test several times to be sure shift events consistently occur at same speeds.
- (2) Test for full-throttle downshifts can be made on a steep hill. If steep hill is not available, condition can be simulated on level road by light, continuous, brake application.

*c. Other Checks During Road Test.* During road test, make operating oil pressure test (par. 198b); also when making road test, be constantly alert for unusual noises (par. 200), and any other indications of irregular or improper transmission performance. After road test is made and malfunctions noted, refer to paragraph 90 for various improper operating conditions which may be found, possible causes, and suggested remedies.

Table X. Transmission Automatic Shift Pattern

UPSHIFTS			
Shift	(F-1 LEVEL HIGH RANGE.) To detent engine rpm	(F-1 LEVEL HIGH RANGE.) Through detent engine rpm	(F-2 HILLY HIGH RANGE.) Engine rpm
1st to 2d.....	2,860 to 3,230.....	3,190 to 3,600.....	3,190 to 3,600.
2d to 3d.....	3,130 to 3,370.....	3,400 to 3,680.....	
3d to 4th.....	2,790 to 3,100.....	3,220 to 3,500.....	3,220 to 3,500.
DOWNSHIFTS			
Shift	(F-1 LEVEL HIGH RANGE.) To detent engine rpm	(F-1 LEVEL HIGH RANGE.) Through detent engine rpm	(F-2 HILLY HIGH RANGE.) Engine rpm
4th to 3d.....	1,000 to 1,100.....	1,900 to 2,050.....	1,900 to 2,050.
3d to 2d.....	1,360 to 1,515.....	1,470 to 1,630.....	1,470 to 1,735.
2d to 1st.....	1,260 to 1,470.....	1,260 to 1,525.....	1,260 to 1,525.

## 200. Noise Check

*a. General.* Noises which can be diagnosed as trouble noises in the transmission proper are difficult to detect. There is a certain amount

of normal operating noise during transmission operation which is typical of any such unit when in operation. Normal operating and trouble noises in other power train units (engine, transfer, axles, etc) can be transmitted to transmission, preventing positive isolation of actual transmission trouble noises until those other units have been eliminated as possible cause of noise. Before any test for noise is made, engine should be tuned to run smoothly. Make test for noise in a reasonably quiet spot.

*b. Front Oil Pump Noise.* Front oil pump noise may be heard as a sharp shrill whine and is most noticeable when pump is under load. Pitch is steady when driving vehicle forward and does not change like differential noise. Front pump whine may be heard with transmission control lever in N, HIGH RANGE position and engine speed increased. Make a systematic check for front pump noise as described in (1) through (4) below.

- (1) With truck standing and engine running at idling speed, move transmission control lever into N, HIGH RANGE position and listen for whine.
- (2) Raise engine speed gradually. Front pump whine, if present, may be more pronounced at a certain engine speed.
- (3) Move transmission control lever into F-1, HIGH RANGE position and drive vehicle forward, gradually increasing vehicle speed so that engine speed will be the same as when whine was most pronounced ((1) and (2) above). Front pump (if noisy) will again be heard at same engine speed as when vehicle was standing.
- (4) Drive vehicle forward at a speed of 25 to 35 mph and listen for pump whine. Turn off ignition and quickly move control lever into N, HIGH RANGE position. If whine was heard while shifting through all speeds and was loudest between 25 and 35 mph, then disappeared when ignition was turned off (control lever in N, HIGH RANGE), front oil pump is causing noise. Report condition to ordnance maintenance personnel.

*c. Rear Unit Planet Gear Noise.* With vehicle standing, engine idling, and transmission control lever in N, HIGH RANGE position, noisy rear unit planet gears may be heard as a low growl. Growl increases to a very high pitched whine as engine speed is increased. Make test for noisy rear unit planet gears as described in (1) and (2) below.

- (1) *Rear unit planet gear noise (vehicle standing).*
  - (a) Drive vehicle to a reasonably quiet spot and stop.
  - (b) Move transmission control lever into N, HIGH RANGE position.

(c) With engine running at idling speed, listen for noise. Accelerate engine to a higher speed. Rear unit planet gear whine (if present) will increase to a very high pitch as engine speed is increased.

(2) *Rear unit planet gear noise (vehicle moving).*

(a) Drive vehicle forward with control lever in F-1, HIGH RANGE position. Accelerate and decelerate through second speed. Rear unit planet gear noise, if present, will be very noticeable in second speed and will disappear after transmission shifts into third or fourth speed.

(b) If rear unit planet gears proved noisy ((1) and (2) above), report condition to ordnance maintenance personnel.

*d. Front Unit Planet Gear Noise.* Front unit planet gear noise is similar to front oil pump noise, but of a higher pitch. To test for front unit planet gear noise, drive vehicle forward with transmission control lever in F-1, HIGH RANGE position. Accelerate and decelerate through third speed. If front unit planet gears are noisy, whine will be heard in third speed. Report condition to ordnance maintenance personnel.

*e. Scraping Torus Member Noise.* Noise from scraping torus members can be identified by a metallic scraping sound at front of transmission. Driven torus may be striking flywheel, or driving torus may be striking driven torus or torus cover. If driven torus strikes flywheel, cause is usually due to loose main shaft nut, or main shaft nut lock plate broken or not bent over nut. If driving torus strikes driven torus, cause is usually due to a missing or broken driving torus spring retainer, or to improper main shaft end play. Remove transmission and tighten or secure main shaft nut, install driving torus spring retainer, or install new torus members as necessary (pars. 204 and 205). If noise continues at torus members, notify ordnance maintenance personnel.

*f. Rear Oil Pump Noise.* Rear oil pump noise may be heard as a high pitched whine much like rear axle noise, but not sensitive to throttle opening, drive, float, and coast. Rear oil pump whine in most cases will be heard when driving forward between 20 to 35 mph. It is seldom heard below 20 mph. Rear axle whine may be audible at other speeds. Test for rear oil pump noise as described in (1) through (4) below.

(1) Drive vehicle forward to determine at what speed noise is heard.

(2) With vehicle moving forward, move transmission control lever into N, HIGH RANGE position and quickly turn off ignition. Coast down only through speed at which noise was heard.

**Caution:** Coast only a short distance to avoid damage to transmission.