

TECHNICAL MANUAL

**DIRECT SUPPORT AND GENERAL SUPPORT
MAINTENANCE MANUAL**

(INCLUDING REPAIR PARTS AND SPECIAL TOOLS LISTS)

FOR

**PUMP, FUEL, METERING AND DISTRIBUTING,
ASSEMBLY 2910-178-1185, 2910-759-5410,
2910-908-6320, 2910-968-6317
AND 2910-116-8241**

This copy is a reprint which includes current
pages from Changes 1 and 2.

HEADQUARTERS, DEPARTMENT OF THE ARMY

JUNE 1974

CAUTION

Absolute cleanliness of fuel pump parts must be maintained during all disassembly, inspection, repair, and assembly procedures. Dust, dirt, grime, or any abrasive matter must not come in contact with precision lapped surfaces of internal parts (para 3-2).

Support the pump housing so that the timing pointer will not be damaged (para 3-16b).

Care should be exercised during installation of the compensator on code A pumps. The top of the fuel control link is not secured to the piston shaft. If the top of the link does not remain engaged in the shaft, the stop plate will fall into the governor housing causing serious damage to the pump (para 3-46a). Do not allow the fuel pressure to exceed 400 psi (para 3-51g).

END ITEM APPLICATION

ENGINE, DIESEL (MULTIFUEL); TURBOCHARGED, FUEL INJECTED, WATER COOLED, 6-CYLINDER ASSEMBLY (MILITARY MODELS LDS-427-2, LD-465-1, LD-465-1C, LDT-465-1C, LDS-465-1, LDS-465-1A, AND LDS-465-2).

CHANGE }
 No. 2 }

HEADQUARTERS
 DEPARTMENT OF THE ARMY
 WASHINGTON, DC 24 September - 1976

**Direct Support and General Support
 Maintenance Manual
 (Including Repair Parts and Special Tools Lists)
 For
 PUMP, FUEL, METERING AND DISTRIBUTING,
 ASSEMBLY 2910-178-1185, 2910-759-5410,
 2910-908-6320, 2910-968-6317
 AND 2910-116-8241**

TM 9-2910-226-34, 28 June 1974, is changed as follows:

1. Remove old pages and insert new pages as indicated below. Changed material is indicated by a vertical bar in the margin of the page.

Remove Pages

3-71 and 3-72
 3-85 and 3-86
 3-99 and 3-100
 3-113 and Blank

Insert Pages

3-71 and 3-72
 3-85 and 3-86
 3-99 and 3-100
 3-113 and Blank

2. File this change sheet in the front of the publication for reference purposes.

By Order of the Secretary of the Army:

Official:

PAUL T. SMITH
*Major General, United States Army
 The Adjutant General*

FRED C. WEYAND
*General, United States Army
 Chief of Staff*

Distribution:

To be distributed in accordance with DA Form 12-38, Direct and General Support maintenance requirements for Trucks: 2-1/2 Ton, M34 and M35 Series, 5 Ton, M39 Series, 5 Ton, M656 Series and 5 Ton, M809 Series.

TM 9-2910-226-34

CHANGE No. 1

HEADQUARTERS
DEPARTMENT OF THE ARMY
WASHINGTON, D.C. 18 November 1974

**Direct Support and General Support
Maintenance Manual
(Including Repair Parts and Special Tools Lists)
For
PUMP, FUEL, METERING AND DISTRIBUTING,
ASSEMBLY 2910-178-1185, 2910-759-5410,
2910-908-6320, 2910-968-6317
AND 2910-116-8241**

TM 9-2910-226-34, 28 June 1974, is changed as follows:

1. Remove old pages and insert new pages as indicated below. Changed material is indicated by a vertical bar in the margin of the page.

Remove Pages

3-109 and 3-110

Insert pages

3-109 and 3-110

2. File this change sheet in the front of the publication for reference purposes.

By Order of the Secretary of the Army

FRED C. WEYAND

*General, United States Army
Chief of Staff*

Official:

VERNE L. BOWERS

*Major General, United States Army
The Adjutant General*

Distribution:

To be distributed in accordance with DA Form 12-38, Direct and General Support maintenance requirements for Trucks, Cargo, 2½ Ton, M34, M35, M35A1, M35A2, M35A20, M35E8, M36A2, M35C, M135, M211, 5 Ton, M41, M54, M55, M656, M813, M813A1, M814; Dump, 2½ Ton, M47, M59, M215, M372, 5 Ton, M51; Tank, Gasoline, 2½ Ton, M49, M49A1C, M49A2C, M49C, M217, M217C; Tank, Water, 2½ Ton, 1000 Gallon, M50, M50A1, M50A2, M222; Tractor, 2½ Ton, M48, M221, M275, M275A1, M275A2, 5 Ton, M52, M246, M757, M816, M818, M819; Wreckers, Medium, M62, M543.

TAGO 3244A

TECHNICAL MANUAL }
 No. 9-2910-226-34 }

HEADQUARTERS
 DEPARTMENT OF THE ARMY
 WASHINGTON, D. C., 28 June 1974

DIRECT SUPPORT AND GENERAL SUPPORT MAINTENANCE
(INCLUDING REPAIR PARTS AND SPECIAL TOOLS)
PUMP, FUEL, METERING AND DISTRIBUTING, ASSEMBLY

2910-178-1185, 2910-759-5410, 2910-908-6320,
2910-968-6317 AND 2910-116-8241

Current as of January 1974

		Paragraph	Page
CHAPTER 1.	INTRODUCTION		
Section 1.	General	1-1-1-1	1-1
II.	Description and data	1-4-1-29	1-13
CHAPTER 2.	DIRECT SUPPORT AND GENERAL SUPPORT MAINTENANCE INSTRUCTIONS		
Section I.	Repair parts, special tools, and equipment	2-1-2-5	2-1
II.	Troubleshooting	2-6-2-9	2-3
CHAPTER 3.	REPAIR OF FUEL INJECTION PUMP		
Section I.	General.	3-1,3-2	3-0
II.	Disassembly of fuel injection pump into subassemblies	3-3-3-16	3-0
III.	Repair of fuel injection pump components.	3-17-3-33	3-11
IV.	Assembly of fuel injection pump from subassemblies	3-34-3-49	3-68
V.	Tests and adjustments	3-50-3-58	3-91
VI.	Repair standards	3-59-3-64	3-110
APPENDIX A.	REFERENCES	A-1	A-1
B.	REPAIR PARTS AND SPECIAL TOOLS LISTS.	B-1- B-8	B-1
INDEX			I-1

*This manual supersedes TM 9-2910-223-35, 13 January 1964, including all changes; and TM 9-2910-226-35, 13 October 1964, including all changes.

CHAPTER 1

INTRODUCTION

Section I. GENERAL

1-1. Scope. This manual contains instructions for direct and general support maintenance of the Metering and Distributing Fuel Injection Pump Assembly (fig. 1-1 through 1-12). It contains descriptions of, and procedures for troubleshooting, disassembly, inspection, repair, and assembly. The pumps are used on multifuel engines as listed below. To differentiate between pump models, each pump model has been assigned a code letter. Paragraphs and illustrations which apply to different models will have the defining code letter as part of their title (i. e. Code A pump). LDS-465-1 and LDS-427-2 engines were equipped with two or more different pumps that were installed during production of the engines. The LDS-465-1 pumps will be defined as Early Code F and Late Code F pumps. The LDS-427-2 engines were equipped with three different pumps and these pumps will be defined as Early Code G, Late Code G,

and Rebuild Code G pumps. Where illustrations apply to all pumps no differentiation will be made in the title or the word "typical" will be inserted. Although some engines used the same pump, the pumps have been assigned different code letters to retain engine identity.

<i>Engine model</i>	<i>Part Number</i>	<i>Federal stock number</i>	<i>Pump code</i>
LDS-465.2	11641907	2910.178-1185	A
LDS-465.1A	10951115	2910-908-6320	B
LD-465-1	10935264	2910-759-5410	C
LD-465-1C	10935264	2910-759-5410	D
LDT-465-1C	10935264-2	2910-116-8241	E
LDS-465-1	*10935498	2910-017-9778	F (early)
	10951115	2910-908-6320	F (late)
LDS-427-2	7748899	2910-860-2333	G (early)
	10935295	2910-968-6317	G (late)
	* 11640900		G (rebuild)

* Not a supply item. Repair parts are identified in the parts section.

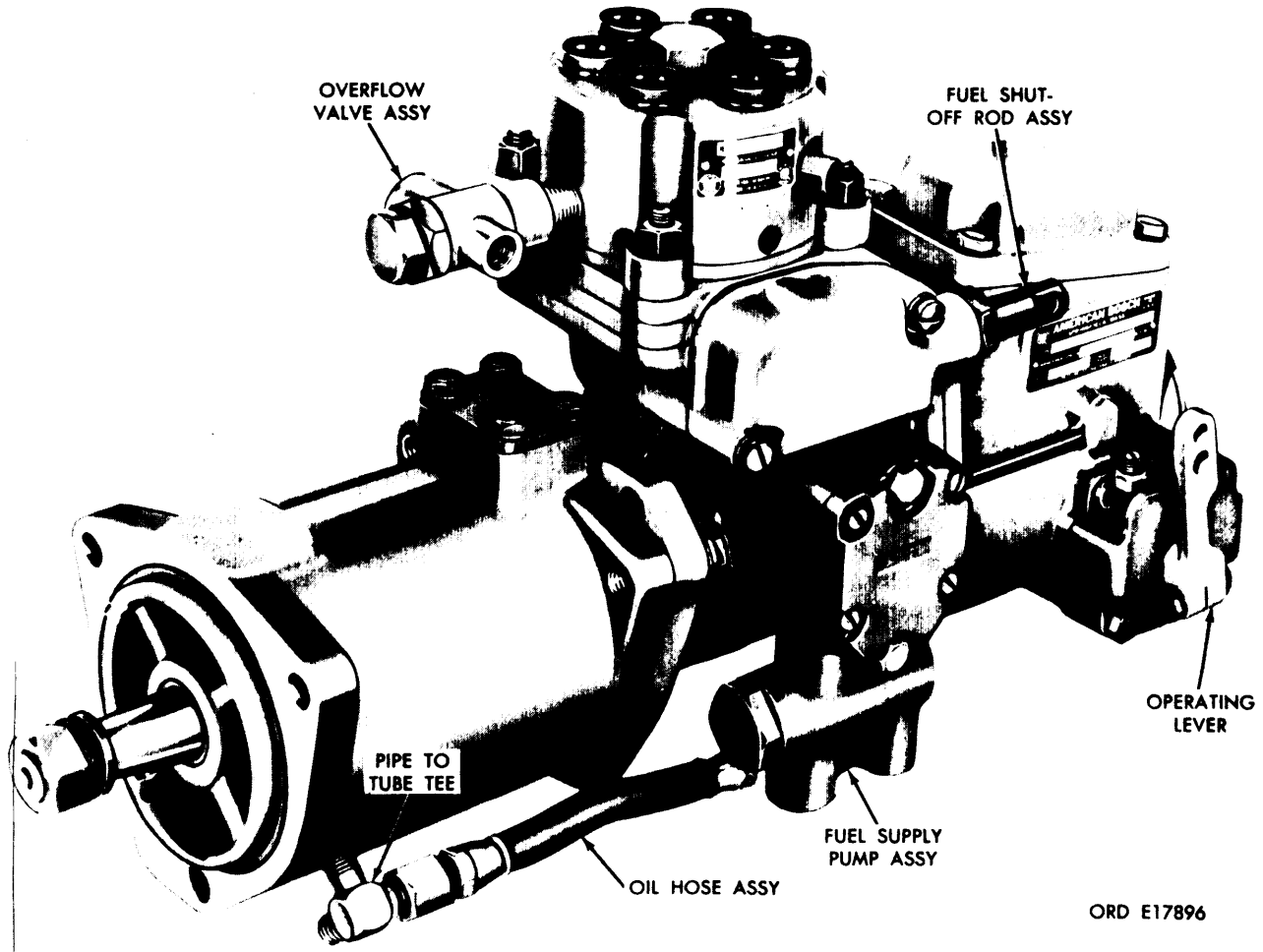

Figure 1-1. Typical metering and distributing fuel injection pump assembly (early code G), left front view.

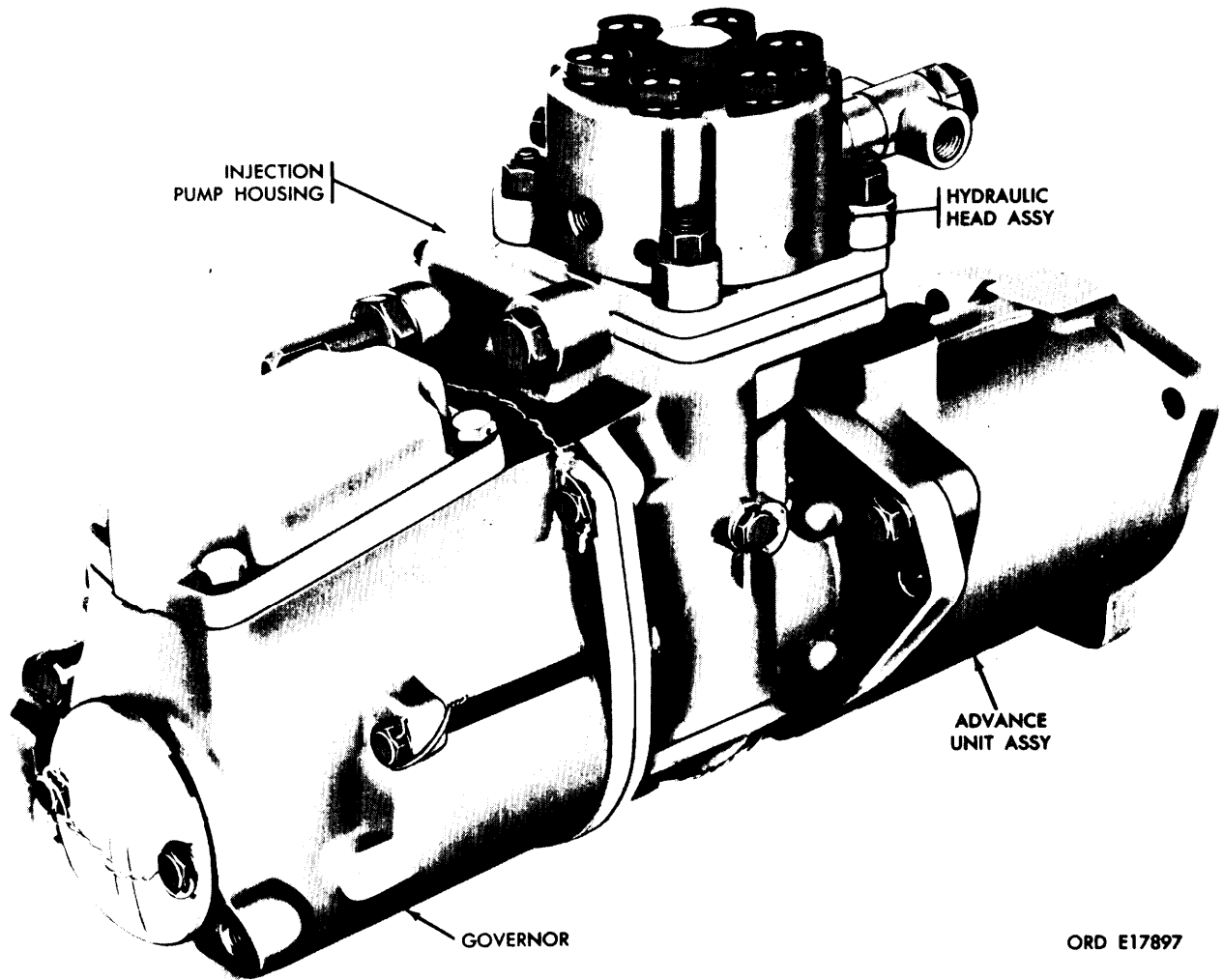
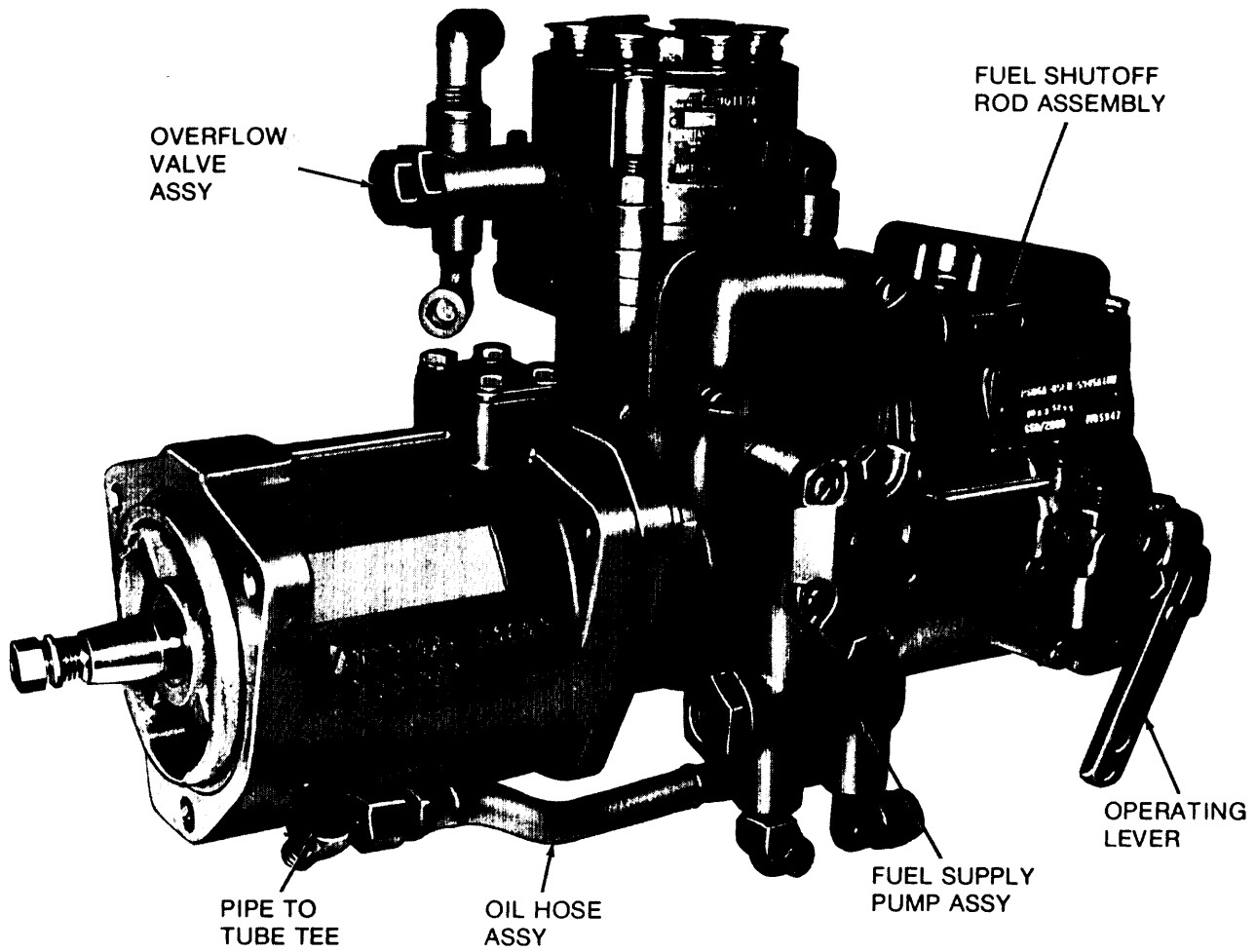

Figure 1-2. Typical metering and distributing fuel injection pump assembly (early code G), right rear view.



TA013701

Figure 1-3. Metering and distributing fuel injection pump assembly (late code G), left front view.

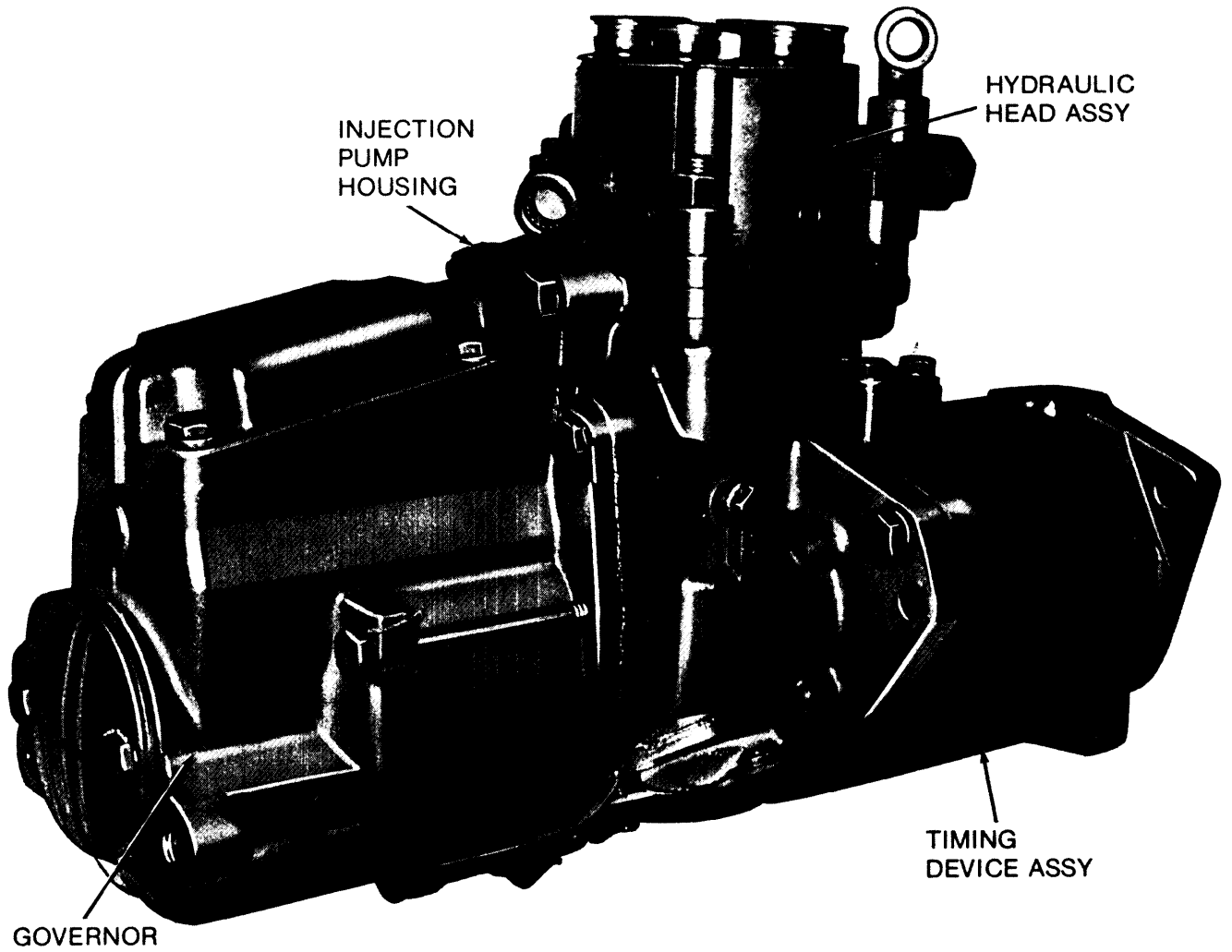
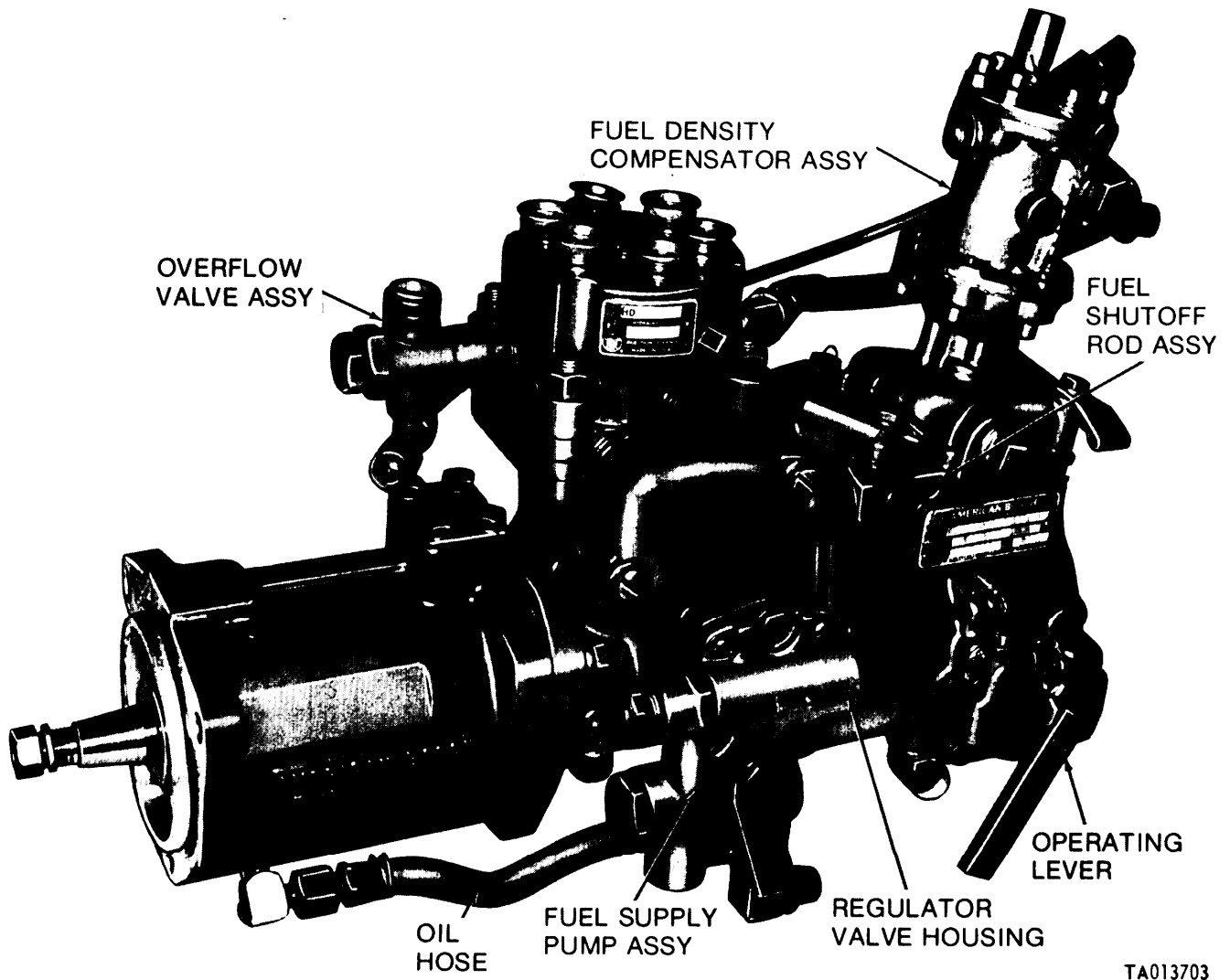

Figure 1-4. Metering and distributing fuel injection pump assembly (late code G), right rear view.

TA013702



TA013703

Figure 1-5. Metering and distributing fuel injection pump assembly (early code F), left front view.

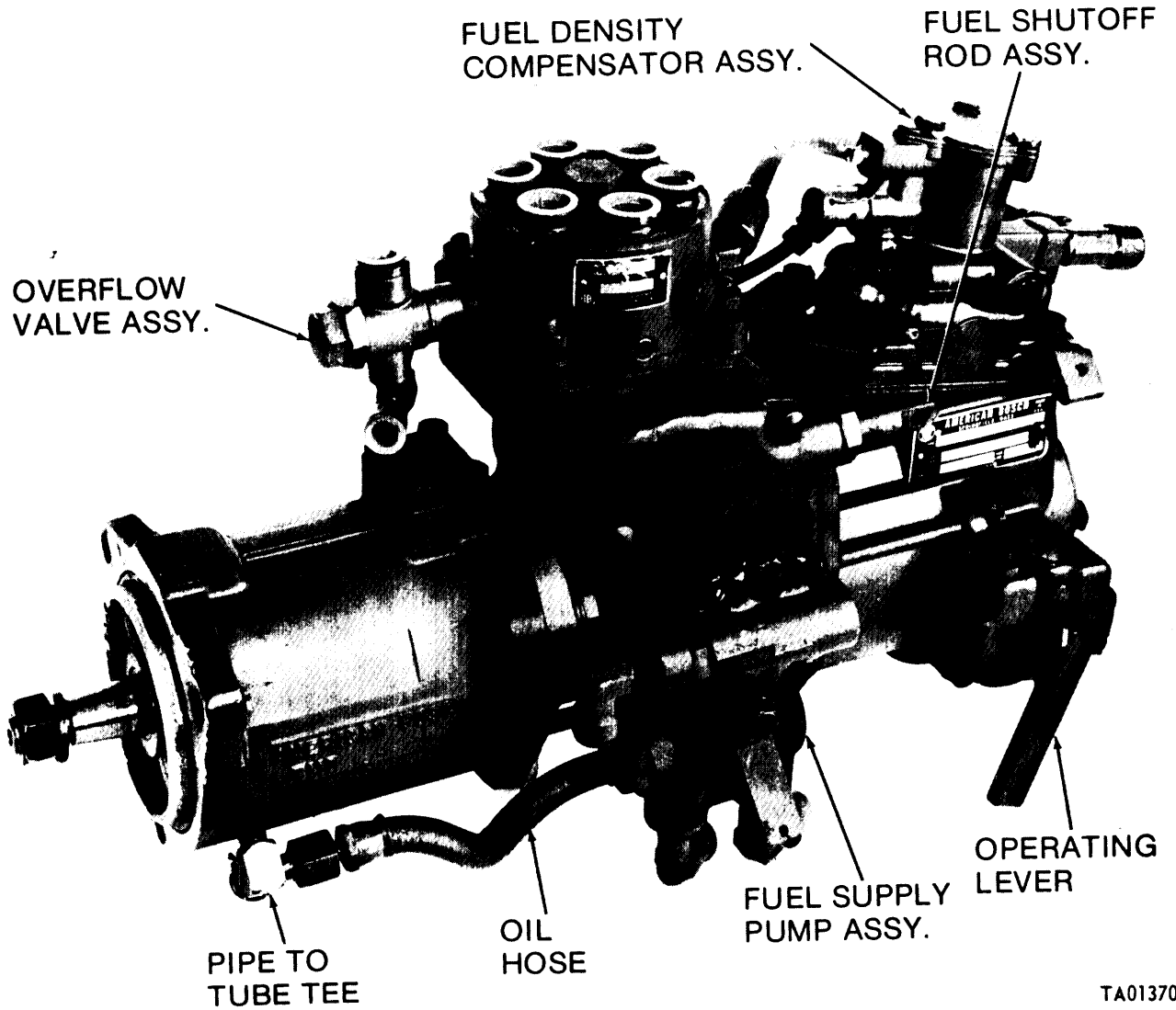

TA013704

Figure 1-6. Metering and distributing fuel injection pump assembly (late code F), left front view.

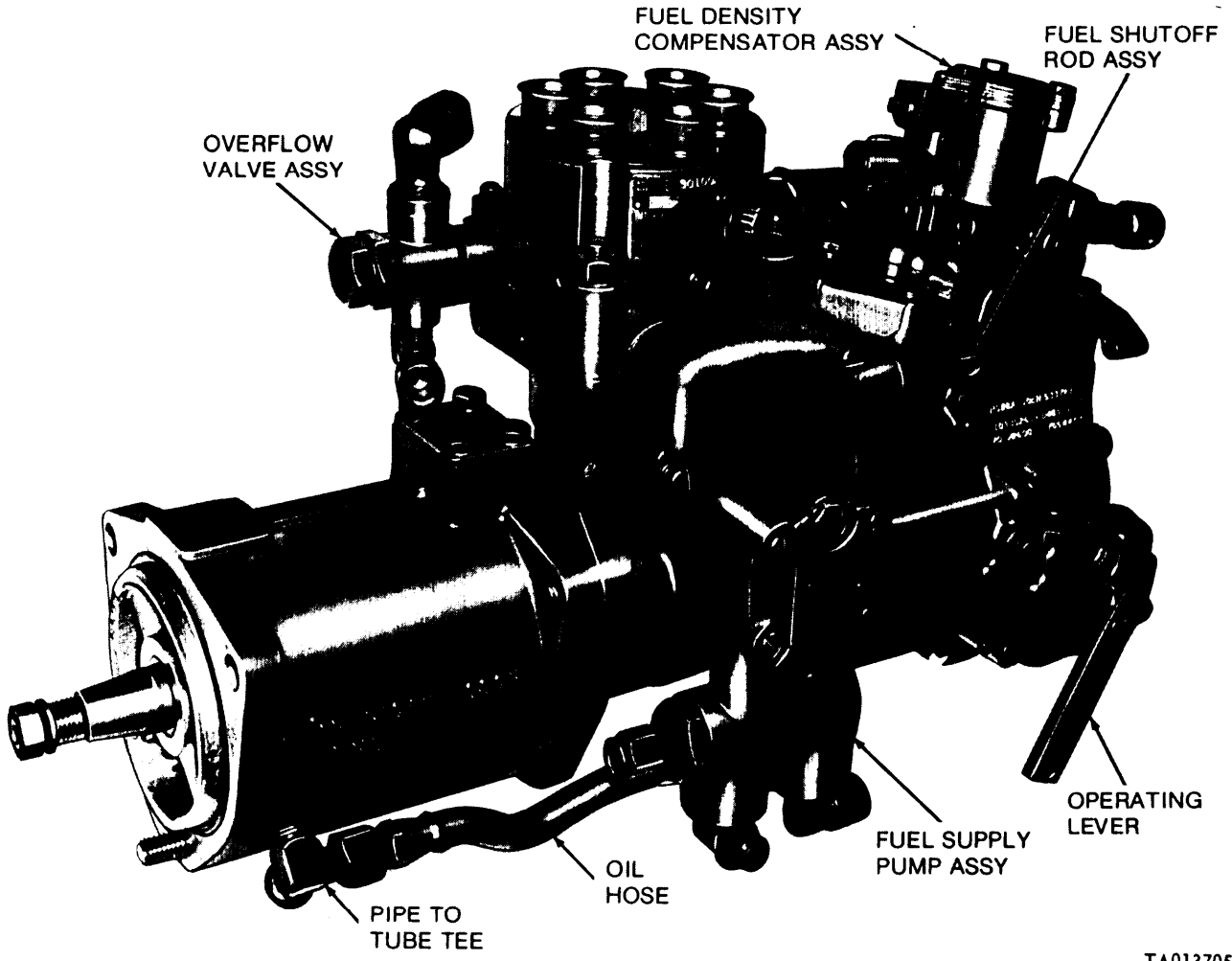

TA013705

Figure 1-7. Metering and distributing fuel injection pump assembly (codes C, D, and E), left front view.

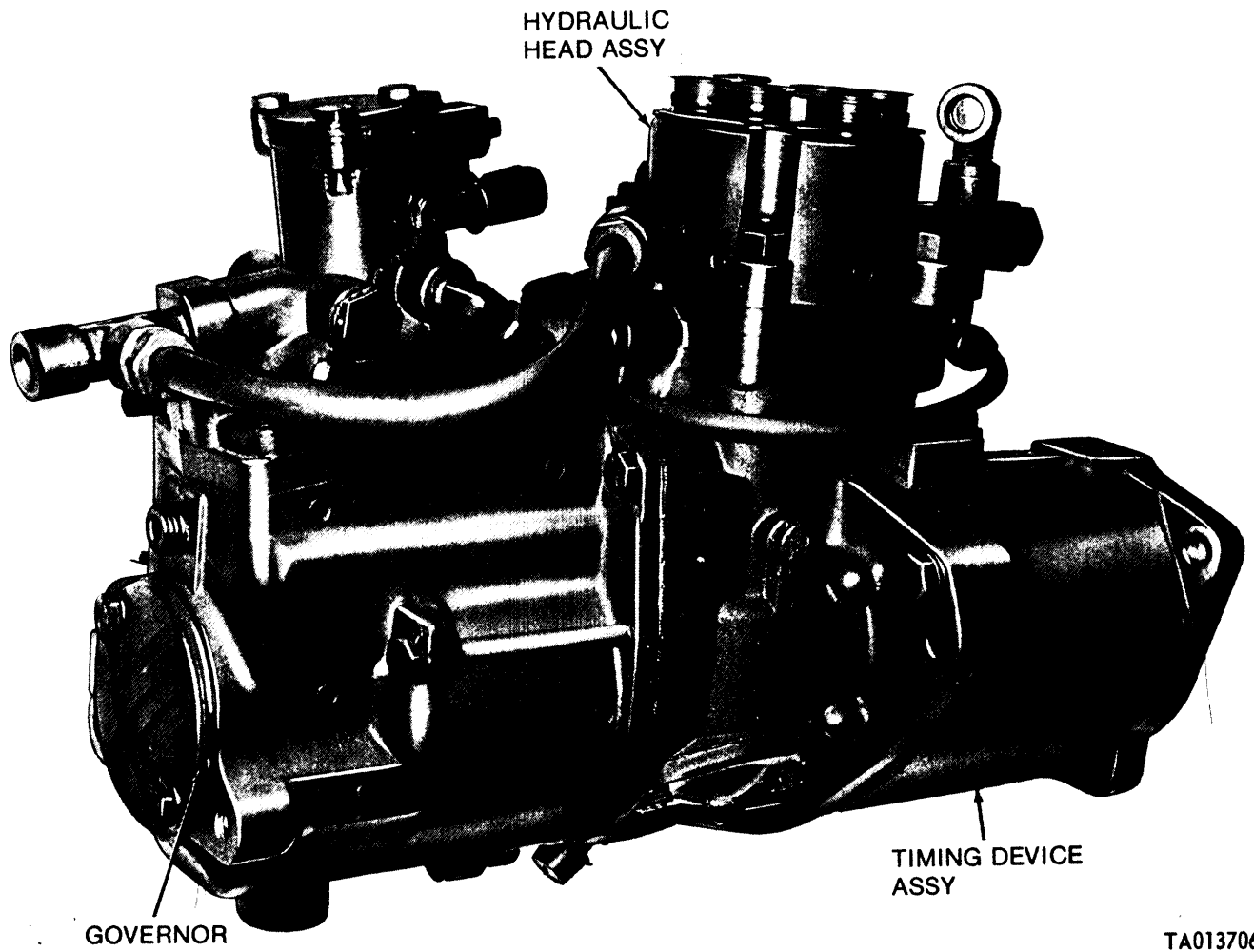
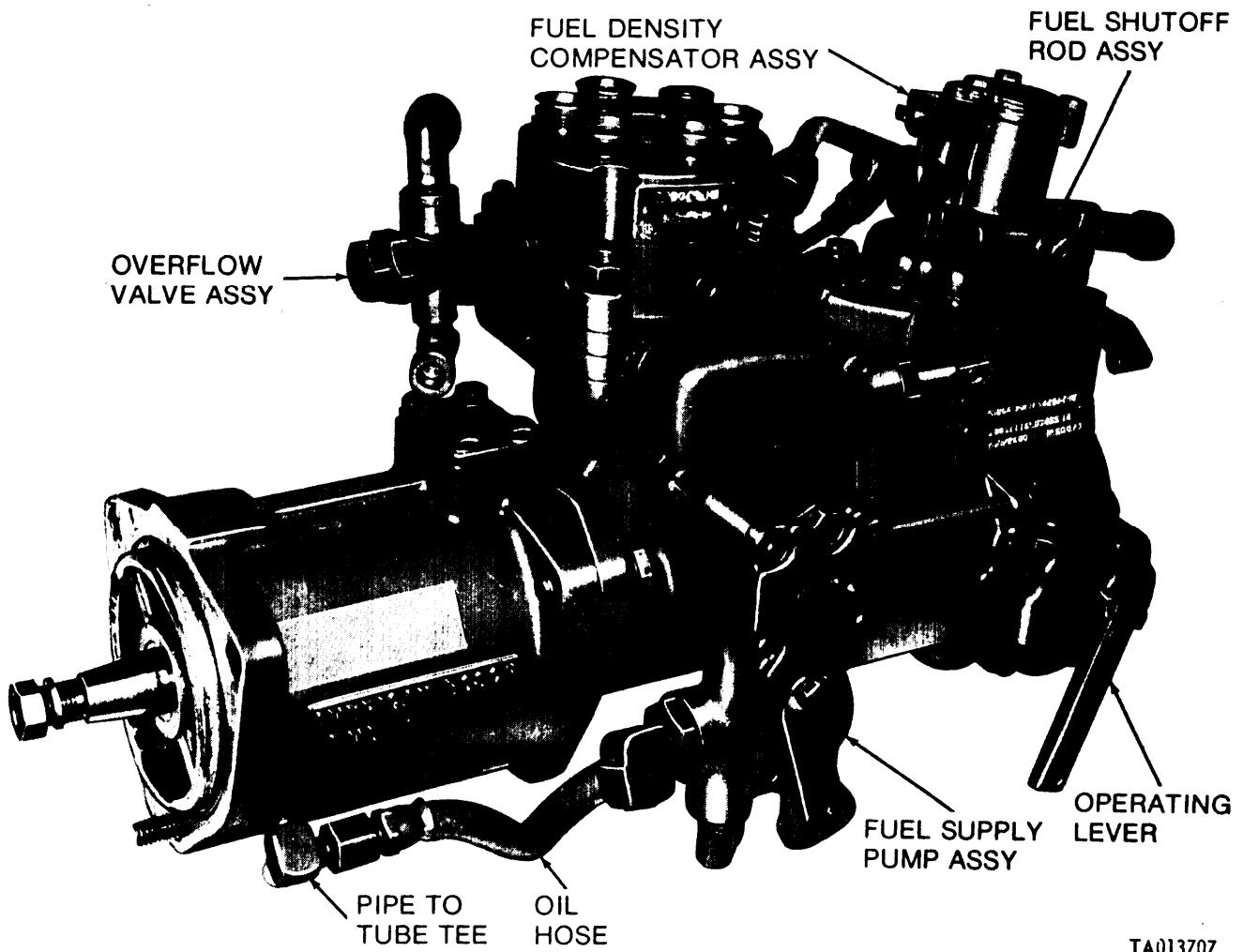

Figure 18. Metering and distributing fuel injection pump assembly (codes C, D and E), right rear view.



TA013707

Figure 1-9. Metering and distributing fuel injection pump assembly (code B), left front view.

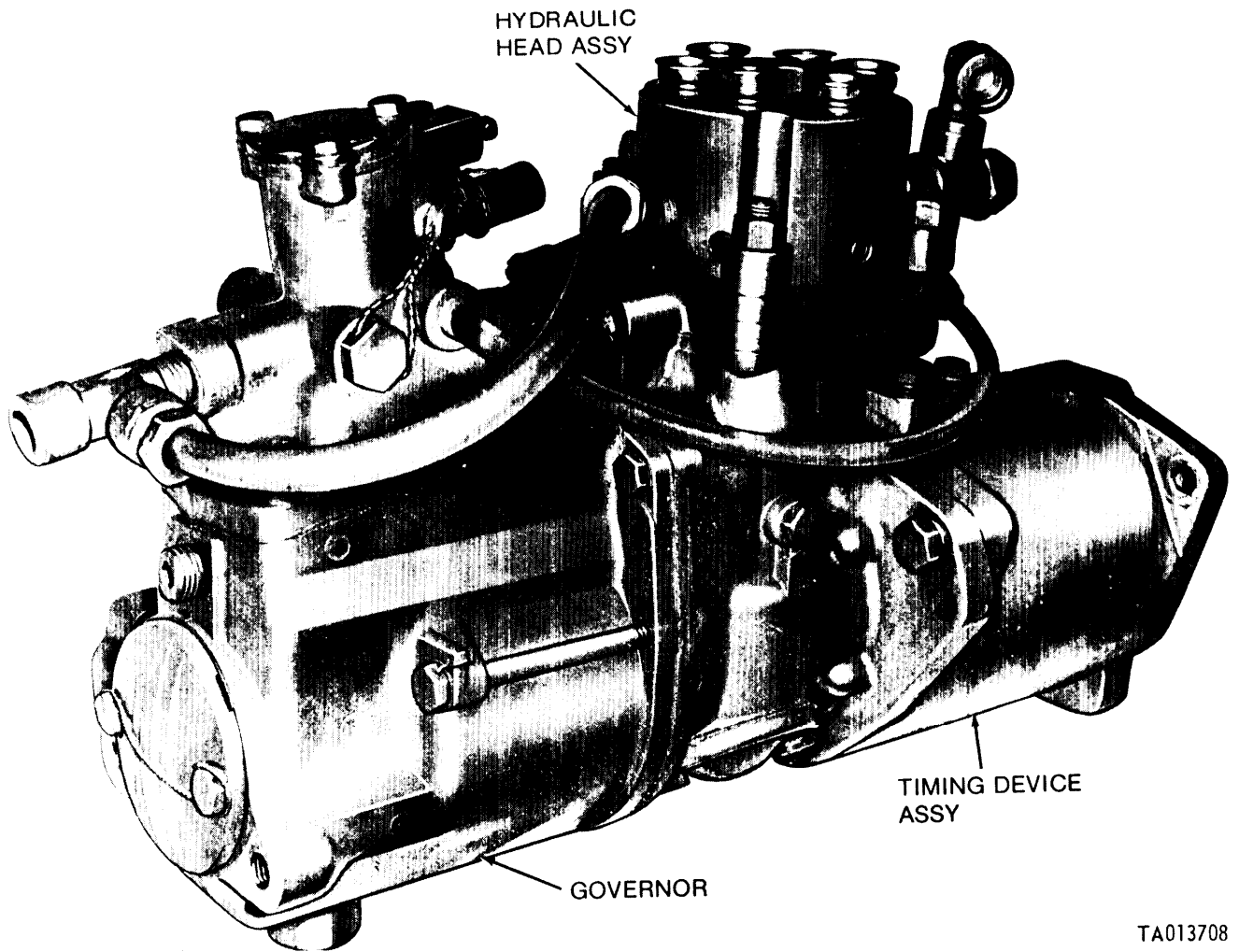

Figure 1-10. Metering and distributing fuel injection pump assembly (code B), right rear view.

TA013708

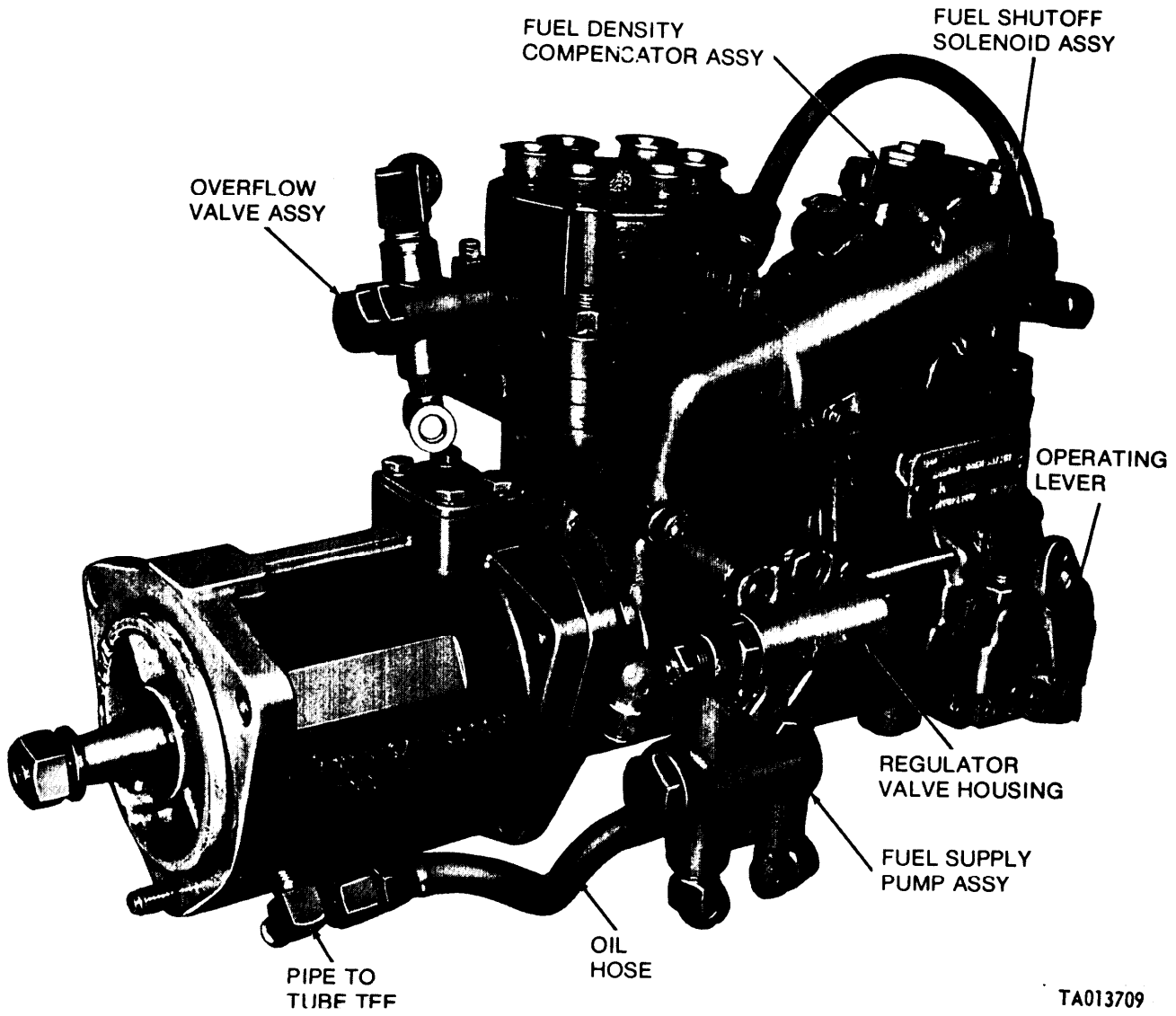
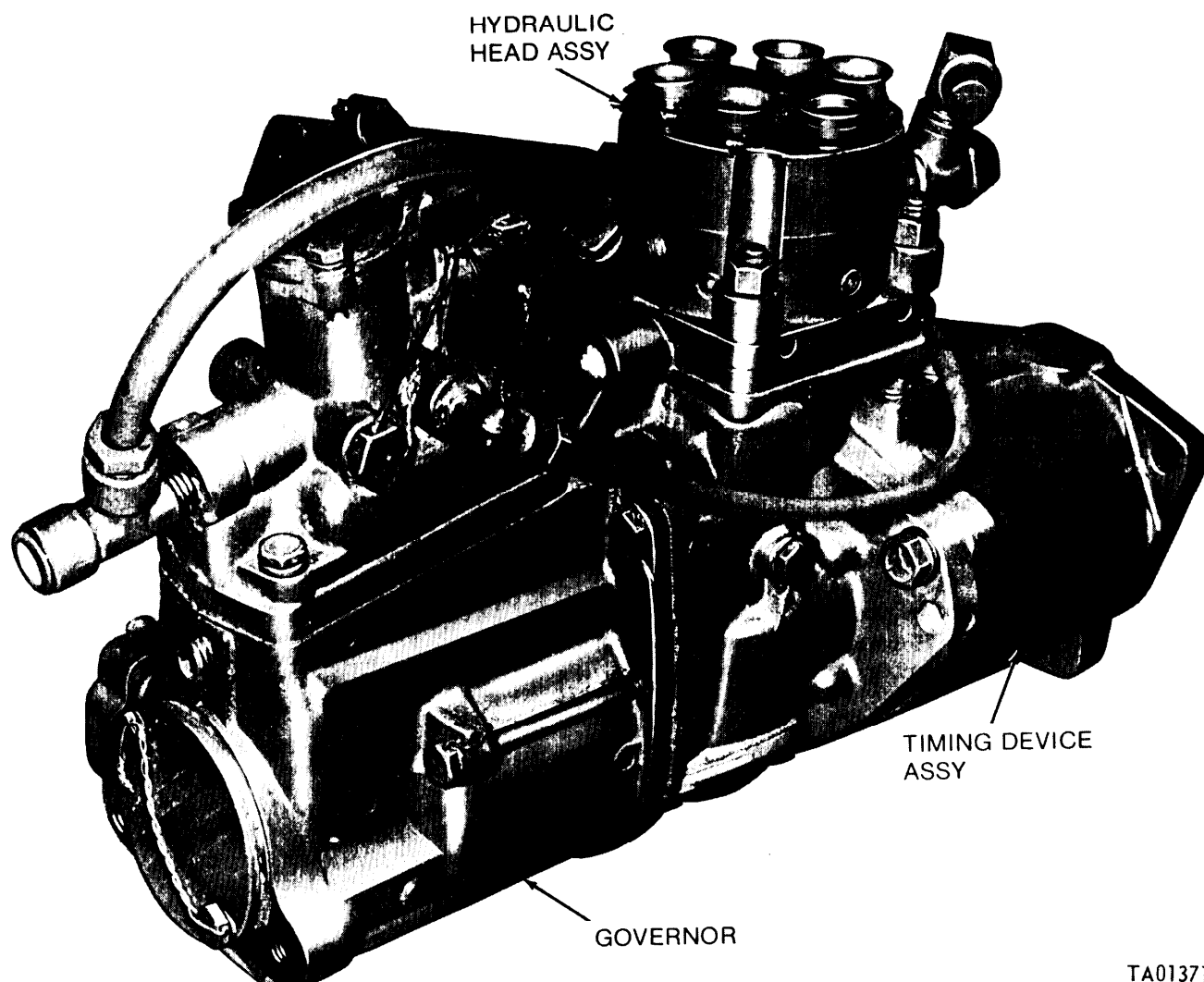

Figure 1-11. Metering and distributing fuel injection pump assembly (code A), left front view.



TA013710

Figure 1-12. Metering and distributing fuel injection pump assembly (code A), right rear view.

1-2. Maintenance Forms and Records. Maintenance forms and records that you are required to use are explained in TM 38-750.

1-3. Recommendation for Maintenance Publications Improvements. You can help to improve this manual by calling attention to errors and by recommending

improvements. Your letter or DA Form 2028 (Recommended Changes to Publications and Blank Forms) should be mailed direct to Commander, US Army Tank-Automotive Command, ATTN: AMSTA-M, Warren, MI 48090. A reply will be furnished direct to you.

Section II. DESCRIPTION AND DATA

1-4. Localization of Fuel Injection Pump Components. *a.* In this manual, the terms defined in *b* and *c* below will be used to describe the location of the fuel injection pump components.

b. The timing device end of the pump will be called the front and the governor end the rear.

c. As viewed from the governor end, the side on the viewer's right will be the right side.

1-5. General. *a.* The metering and distributing fuel injection pump assembly is a constant-stroke, distributing-plunger, sleeve control type. The plunger is actuated by a camshaft and tappet

arrangement. The camshaft also includes gearing for the distribution function. The fuel injection pump contains a single-plunger, multioutlet hydraulic head assembly and is designed to be driven at crankshaft speed on four-cycle engines.

b. The purpose of the fuel injection pump is to deliver accurately metered quantities of fuel under high pressure to the spray nozzle for injection into the engine cylinders.

c. An integral mechanical-centrifugal type governor controls fuel delivery as a function of engine speed. It is driven directly from the rear of the pump camshaft without gearing.

d. The fuel supply pump is the positive displacement type. It is gear driven by the metering and distributing fuel injection pump camshaft. It provides fuel to the hydraulic head for injection and cooling, and fuel to the engine flame heater system.

e. The timing device is the mechanical-centrifugal type. It is driven clockwise by the engine camshaft at crankshaft speed.

f. The fuel density compensator (when used) is mounted on the governor housing. The fuel density compensator automatically varies the quantity of fuel delivered to the engine so that the maximum power output of the engine remains constant regardless of the type of fuel being used.

1-6. Injection Pump Housing. *a.* The aluminum housing is cast with an integral three-hole flange for mounting the advance unit. It has several drilled holes that interconnect to form passages for the flow of lubricating oil supplied to the fuel injection pump from the engine.

b. A quill shaft pad cover (F, fig. 1-13) on the bottom of the housing provides for removal of the

quill shaft assembly during disassembly. A timing window in the upper part of the housing covers the marked plunger gear, which is used for timing during assembly and disassembly. A timing pointer (D, fig. 1-14) at front of fuel injection pump, aligns with a mark on timing device hub (C, fig. 1-14) to show port closing position.

KEY to fig. 1-13

Typical Injection Pump
Code 13, C, D, E, F, G

- A Overflow valve assembly
- B Fuel control unit assembly
- C Fuel control rod
- D Fuel shutoff rod assembly
- E Timing window cover solenoid shutoff assembly.
- F Quill shaft pad cover
- G Camshaft driven gear
- H Shaft spacer
- J Quill shaft retaining screw
- K Quill shaft bushing
- L Quill shaft
- M Plunger sleeve pin
- N Plunger sleeve

Injection Pump
Code A

- A Overflow valve assembly
- B Fuel control unit assembly
- C Fuel control rod
- D Fuel shutoff solenoid
- E Timing window cover solenoid shutoff assembly.
- F Quill shaft pad cover
- G Camshaft driven gear
- H Shaft spacer
- J Quill shaft retaining screw
- K Quill shaft bushing
- L Quill shaft assembly
- M Plunger sleeve pin
- N Plunger sleeve

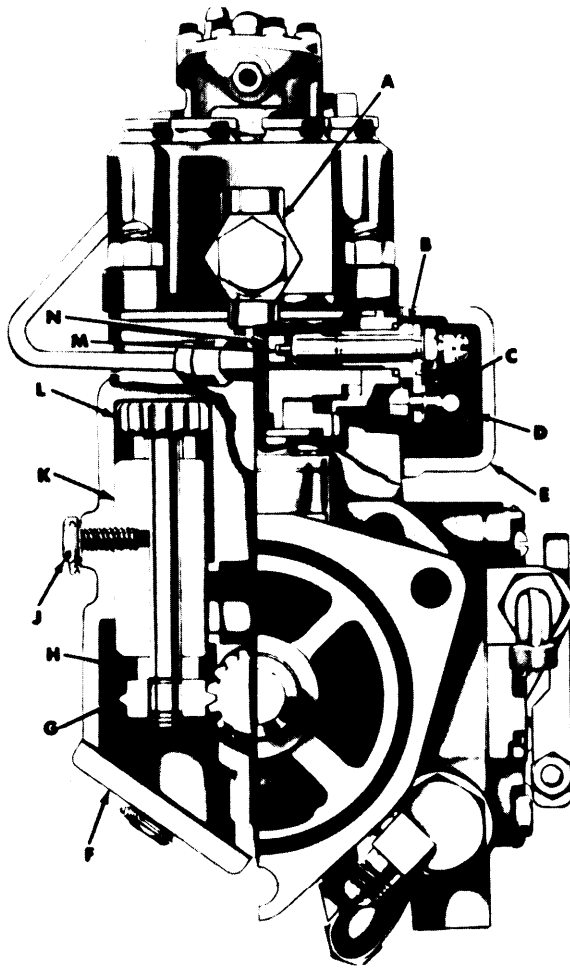

TYPICAL INJECTION PUMP
CODE B, C, D, E, F AND G

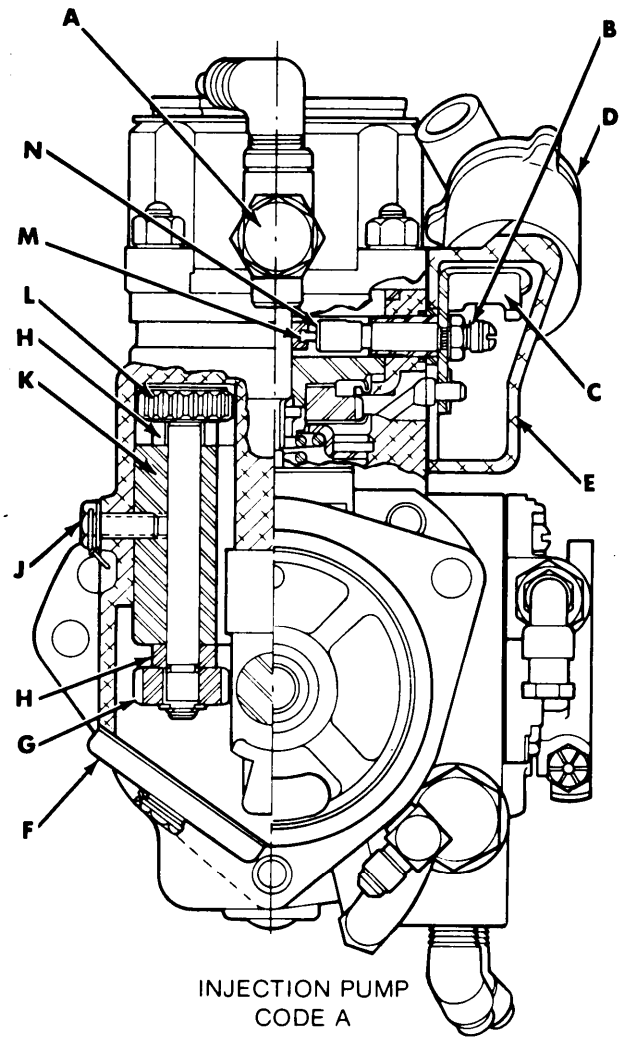

INJECTION PUMP
CODE A

TA013791

Figure 1-13. Metering and distributing fuel injection pump assembly, front sectional view.

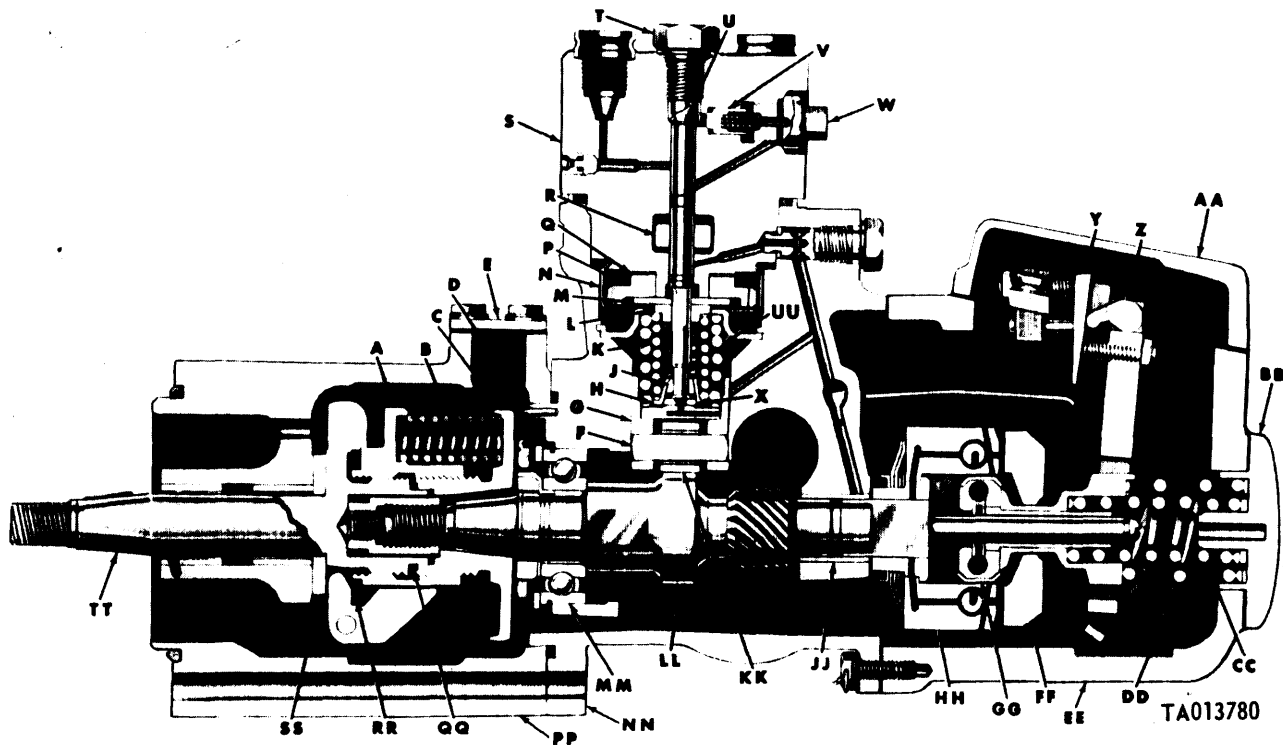

- | | |
|------------------------|----------------------------------|
| A Sliding gear | Y Stop plate |
| B Timing device spring | Z Smoke limit cam |
| C Timing device hub | AA Governor cover |
| D Timing pointer | BB Governor end cap |
| E Timing cover | CC Governor inner spring |
| F Tappet roller pin | DD Governor outer spring |
| G Tappet guide | EE Governor housing |
| H Spring lower seat | FF Governor weight |
| J Plunger lock | CC Sliding sleeve |
| K Plunger inner spring | HH Friction drive spider |
| L Spring upper seat | JJ Camshaft bushing-type bearing |
| M Plunger guide | KK Tappet roller |
| N Drive gear retainer | LL Camshaft |
| P Plunger drive gear | MM Camshaft ball bearing |
| Q Gear thrust washer | NN Injection pump housing |
| R Plunger sleeve | PP Timing device housing |
| S Hydraulic head | QQ End play spacer |
| T Plunger bore screw | RR Sliding gear spacer |
| U Fuel plunger | SS Spider thrust plate |
| V Fuel delivery valve | TT Weight and spider assembly |
| W Delivery valve screw | UU Outer plunger spring |
| X Plunger button | |

Figure 1-14. Metering and (distributing) fuel injection pump assembly (code G), left sectional view.

1-7. Fuel Shutoff Rod Assembly or Solenoid Assembly. The fuel shutoff rod assembly (D, fig. 1-13) or timing window cover solenoid shutoff assembly (E, fig. 1-13) is attached at the hydraulic head timing window. When the fuel shutoff rod is pulled to the rear, or the solenoid is actuated, it engages the fuel control unit (B, fig. 1-13) or the fuel control unit (B, fig. 1-13), and shuts off the fuel.

1-8. Hydraulic Head Assembly.

NOTE

The key letters shown below in parentheses refer to figures 1-14, 1-15, 1-16, and 1-17.

a. The hydraulic head assembly consists of the hydraulic head (S), fuel plunger (U), plunger sleeve (R), plunger drive gear (P), fuel delivery valve (V), plunger inner spring (K), and other related parts.

b. The hydraulic head has a centrally ground and lapped bore into which the fuel plunger fits. It is counterbored and threaded at the upper end for the plunger bore screw (T). Six discharge passages extend symmetrically from the plunger bore and meet six vertical outlet passages. The fuel delivery valve is located in the head and held by a spring and the delivery valve screw (W). A passage from the

delivery valve chamber connects with the plunger bore at the fuel plunger annulus.

c. The hydraulic head is drilled and tapped for fuel inlet and outlet passages. Drilled holes slant

downward through the head into the fuel supply sump. The sump is located at the midsection of the plunger bore and accommodates the plunger sleeve.

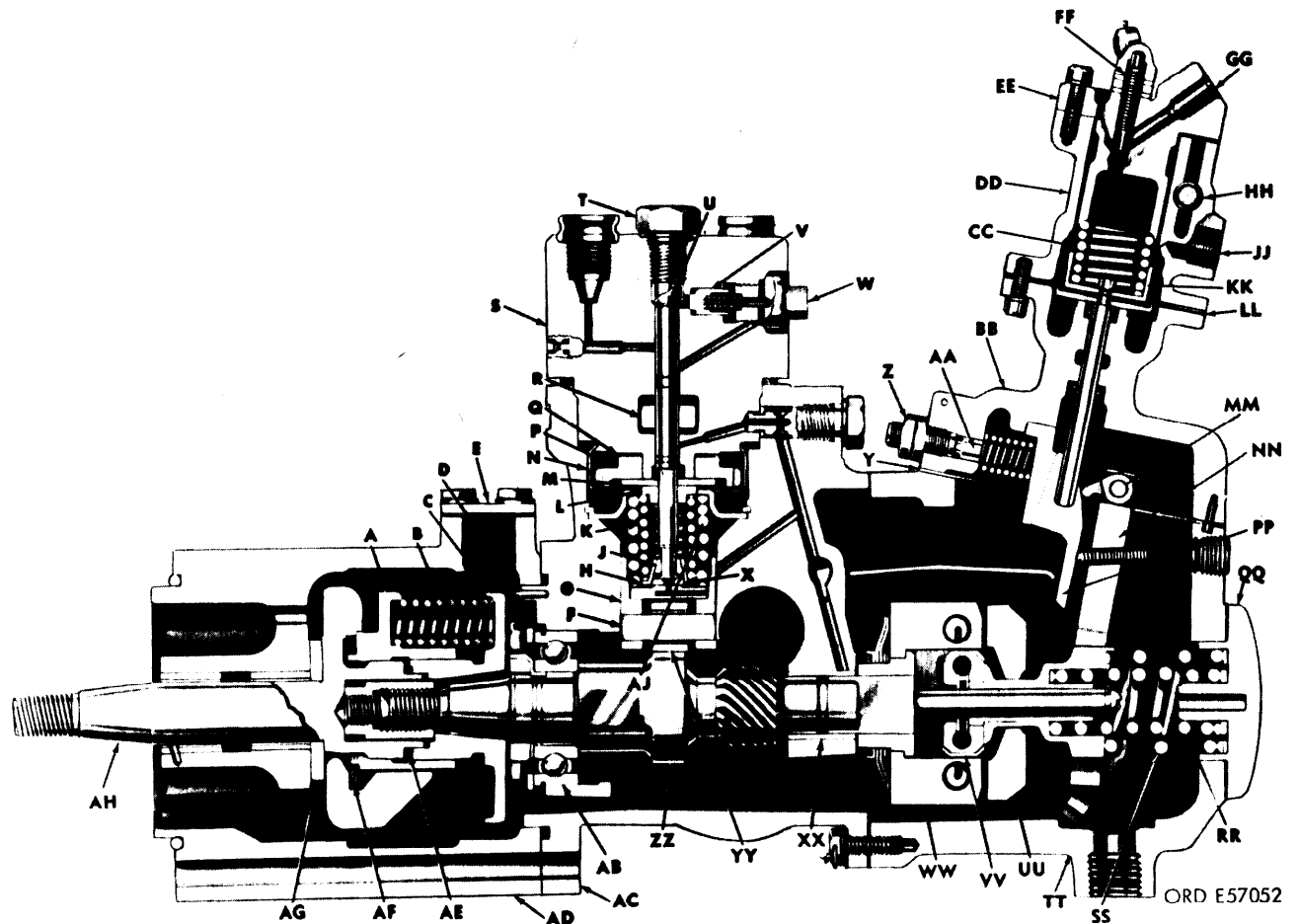

- A Sliding gear
- B Timing device spring
- C Timing device hub
- D Timing pointer
- E Timing cover
- F Tappet roller pin
- G Tappet guide
- H Spring lower seat
- J Plunger lock
- K Plunger inner spring
- L Spring upper seat
- M Plunger guide
- N Drive gear retainer
- P Plunger drive gear
- Q Gear thrust washer
- R Plunger sleeve
- S Hydraulic head
- T Plunger bore screw
- U Fuel plunger

- V Fuel deliver valve
- W Delivery valve screw
- X Plunger button
- Y Density compensator gasket
- Z Guide nut
- AA Guide
- BB Diaphragm housing
- CC Servo spring
- DD Fuel inlet housing
- EE Fuel outlet housing
- FF Servo pressure valve
- GG Fuel outlet port
- HH Pressure regulator valve
- JJ Fuel inlet port
- KK Piston
- LL Inlet housing diaphragm
- MM Smoke limit cam
- NN Governor fulcrum lever
- PP Stop plate

- QQ Governor end cap
- RR Governor inner spring
- SS Governor outer spring
- TT Governor housing
- UU Governor weight
- VV Sliding sleeve
- WW Friction drive spider
- XX Camshaft bushing type bearing
- YY Tappet roller
- ZZ Camshaft
- AB Camshaft ball bearing
- AC Injection pump housing
- AD Timing device housing
- AE End play spacer
- AF Sliding gear spacer
- AG Spider thrust plate
- AH Weight and spider assembly
- AJ Plunger outer spring

Figure 1-15. Metering and distributing fuel injection pump assembly (code F), left sectional view.

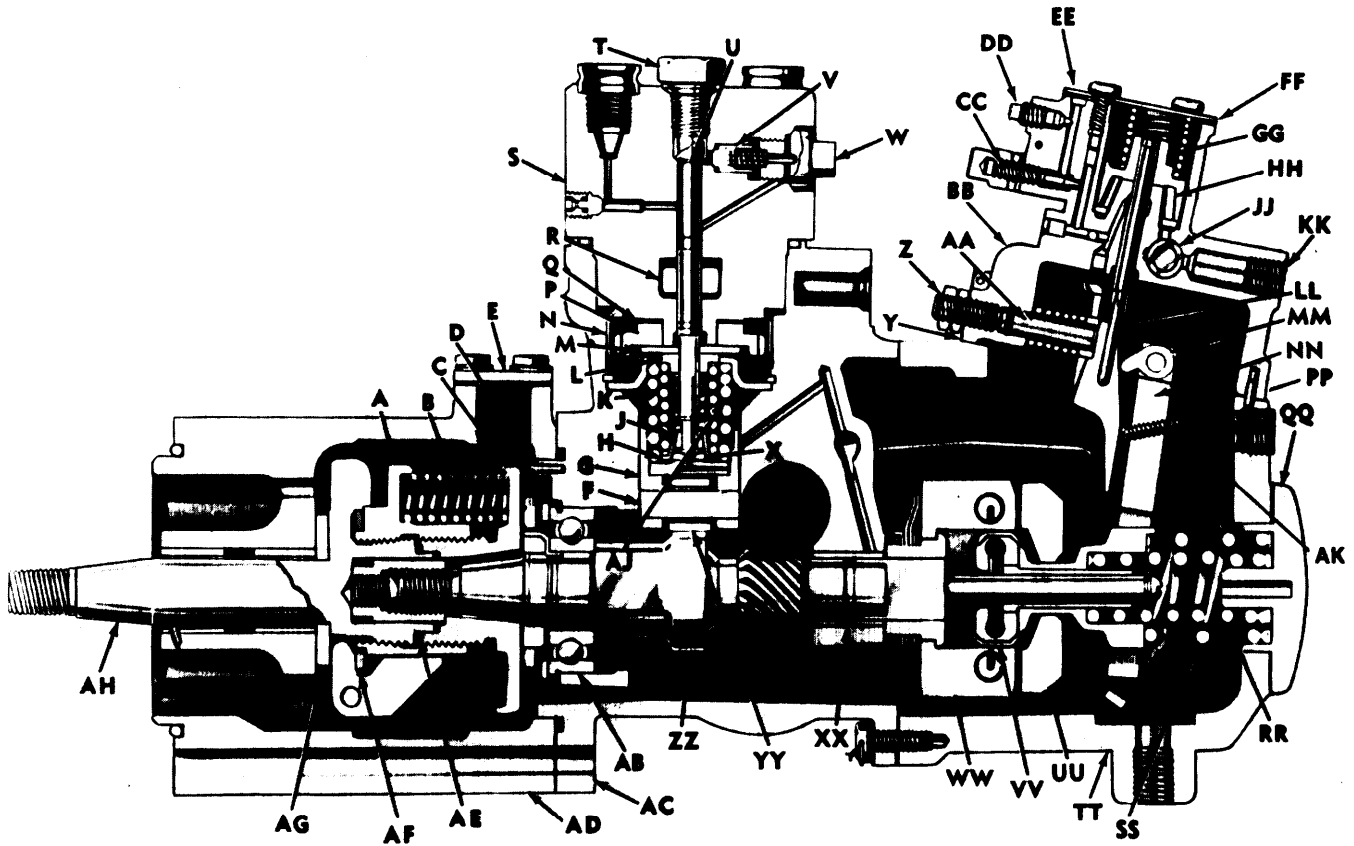

TA013859

- | | | |
|------------------------|--------------------------------|--|
| A Sliding gear | W Delivery valve screw | RR Governor inner spring |
| B Timing device spring | X Plunger button | SS Governor outer spring |
| C Timing device hub | Y Density compensator gasket | TT Governor housing |
| D Timing pointer | Z Guide nut | UU Governor weight |
| E Timing cover | AA Guide | VV Sliding sleeve |
| F Tappet roller pin | BB Density compensator housing | WW Friction drive spider |
| G Tappet guide | CC Servo pressure valve | XX Camshaft bushing type bearing |
| H Spring lower seat | DD Servo pressure tap | YY Tappet roller |
| J Plunger lock | EE Compensator housing cover | ZZ Camshaft |
| K Plunger inner spring | FF Housing cover gasket | AB Camshaft ball bearing |
| L Spring upper seat | GG Servo spring | AC Injection pump housing |
| M Plunger guide | HH Spring piston | AD Timing device housing |
| N Drive gear retainer | JJ Pressure regulating valve | AE End play spacer |
| P Plunger drive gear | KK Fuel inlet port | AF Sliding gear spacer |
| Q Gear thrust washer | LL Piston link | AC Spider thrust plate |
| R Plunger sleeve | MM Smoke limit cam | AH Weight and spider assembly |
| S Hydraulic head | NN Governor fulcrum lever | AJ Plunger outer spring |
| T Plunger bore screw | PP Stop plate | AK Droop screw (use only on code B and E pumps), |
| U Fuel plunger | QQ Governor end cap | |
| V Fuel delivery valve | | |

Figure 1-16. Metering and distributing fuel injection pump assembly (code B, C, D and E), left sectional view.

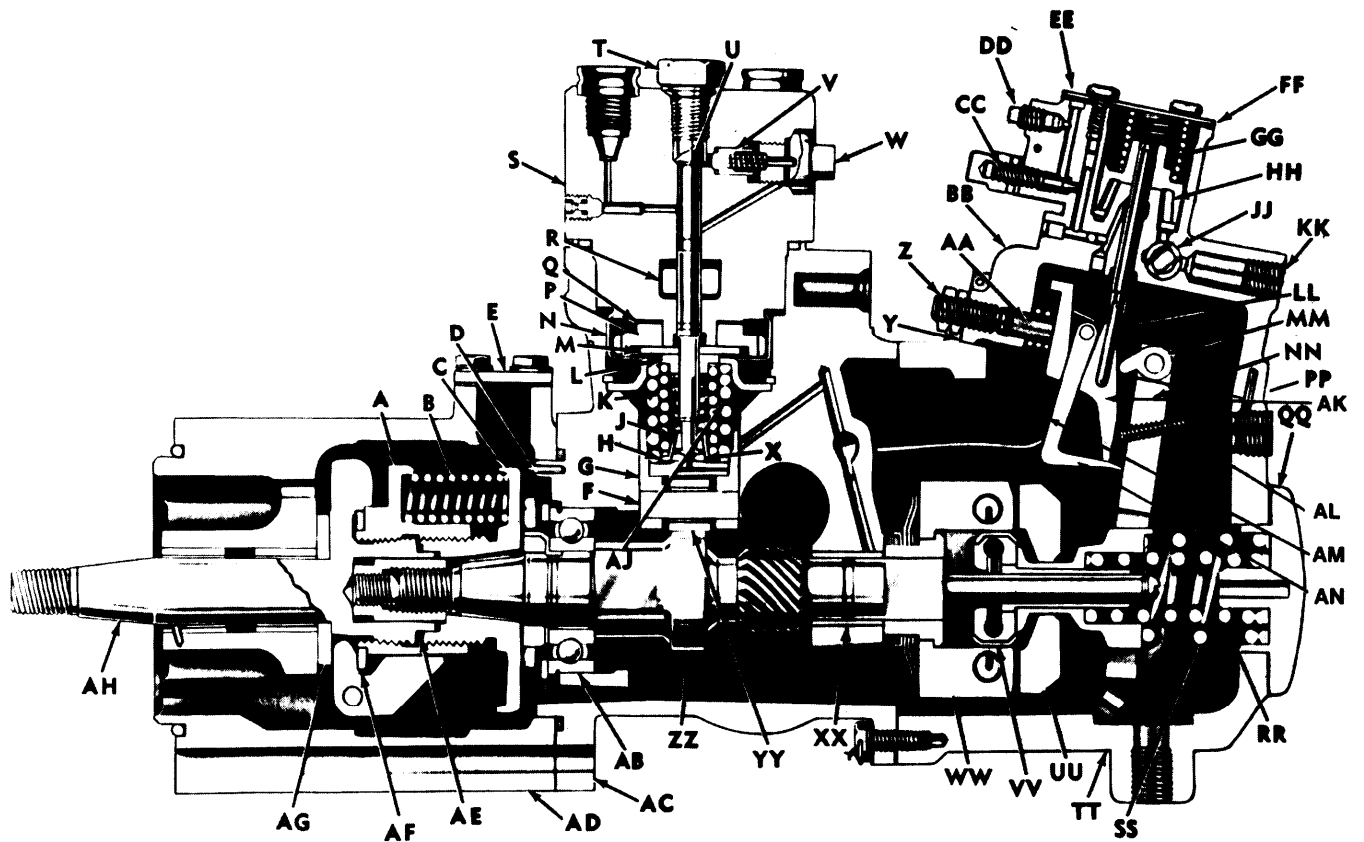

TA013711

- | | | |
|------------------------|------------------------------------|----------------------------------|
| A Sliding gear | W Delivery valve screw | SS Governor outer spring |
| B Timing device spring | X Plunger button | TT Governor housing |
| C Timing device hub | Y Density compensator gasket | UU Governor weight |
| D Timing pointer | Z Guide nut | VV Sliding sleeve |
| E Timing cover | AA Guide | WW Friction drive spider |
| F Tappet roller pin | BB Density compensator housing | XX Camshaft bushing type bearing |
| G Tappet guide | CC Servo pressure adjustment valve | YY Tappet roller |
| H Spring lower seat | DD Servo pressure tap | ZZ Camshaft |
| J Plunger lock | EE Compensator housing cover | AB Camshaft |
| K Plunger inner spring | FF Housing cover gasket | AC Injection pump housing |
| L Spring upper seat | GG Servo spring | AD Timing device housing |
| M Plunger guide | HH Spring piston | AE End play spacer |
| N Drive gear retainer | JJ Pressure regulating valve | AF Sliding gear spacer |
| P Plunger drive gear | KK Fuel inlet port | AC Spider thrust plate |
| Q Gear thrust washer | LL Piston link | AH Weight and spider assembly |
| R Plunger sleeve | MM Smoke limit cam | AJ Plunger outer spring |
| S Hydraulic head | NN Governor fulcrum lever | AK Sliding stop plate |
| T Plunger bore screw | PP Stop plate | AL Droop screw |
| U Fuel plunger | QQ Governor end cap | AM Torque link spring |
| V Fuel delivery valve | RR Governor inner spring | AN Torque link |

Figure 1-17. Metering and distributing fuel injection pump assembly (code A), left sectional view.

NOTE

The hydraulic heads on code F and G injection pumps, (fig. 1-14 and 1-15) had additional passages that directed the flow of lubricating oil to the lower portion of the fuel plunger and the plunger drive gear. If these hydraulic heads are replaced by later model heads it will be necessary to plug the oil passage in the injection pump housing with parts kit 5704374.

d. The fuel plunger is lapped and fitted into the hydraulic head as well as in the plunger sleeve. Two parallel flat surfaces on the lower extension of the fuel plunger lock the plunger drive gear with the plunger guide (M). The plunger guide is designed to shear if the fuel plunger freezes,

e. The drive gear thrust washer (Q) is placed between the drive gear and hydraulic head to take the thrust of the plunger drive gear. The spring upper and lower seats (L and H) and plunger inner spring (K) are held on the plunger by two plunger locks (J). The plunger button (X) mates the round surface of the fuel plunger end to the flat surface of the tappet guide (G). The preceding components are fastened to the head by the drive gear retainer (N). This retainer is cut away to permit the meshing of the plunger drive gear with the quill shaft gear and is also used for fuel pump timing.

1-9. Overflow Valve Assembly. The overflow valve assembly (A, fig. 1-13) returns the excess fuel from the hydraulic head to the vehicle fuel tank. The valve assembly is located on the fuel outlet passage of the hydraulic head. It consists of an overflow valve and valve spring which maintains a constant fuel pressure in the hydraulic head. The overflow valve has a small opening which allows any air accumulation in fuel passages to escape. The opening also serves as a continuous bleed of fuel to permit cooling of the pump.

1-10. Camshaft.

NOTE

The key letters shown in parentheses refer to figure 1-16. The camshaft (ZZ) is supported at the front of the fuel pump housing by the camshaft ball bearing (AB) and at the rear by the camshaft bushing type bearing (XX). The camshaft is comprised of a shaft with a three-lobed cam and a spiral worm gear. The worm gear drives the quill shaft and the fuel supply pump.

1-11. Tappet Assembly.

NOTE

The key letters shown below in parentheses

refer to figure 1-16. The tappet assembly is located between the camshaft and the lower end of the fuel plunger. It consists of a tappet roller (YY), tappet roller pin (F), and a tappet guide (G). The tappet guide contains a slot which rides on the tappet guide pin in the injection pump housing.

1-12. Quill Shaft Assembly.

NOTE

The key letters shown below in parentheses refer to figure 1-13. The quill shaft assembly transmits the rotary motion of the camshaft to the fuel plunger at one-half camshaft speed. The quill shaft assembly consists of a quill shaft (L), quill shaft bushing (K) two shaft spacers (H), and a camshaft driven gear (G). The quill shaft assembly is held in position in the injection pump housing by a machine screw (J).

1-13. Governors (Typical).

NOTE

The key letters shown below in parentheses refer to figures 1-16 and 1-17, except where otherwise indicated.

a. The governor, with its weight and spider assembly attached to the camshaft, is an integral part of the fuel injection pump. The governor is a variable speed, mechanical and centrifugal type. The governing action is accomplished by two governor weights (UU) acting against a movable sliding sleeve (VV) which is backed up by governor inner and outer springs (RR and SS) loaded in opposite directions.

(1) The governor on code A injection pump (fig. 1-1 7) is the same except a torque control link ((D), fig. 1-18) has been added.

(2) The control link retards governor action during automatic transmission shift and does not allow engine speed or torque increase during the change of gear ratios within the transmission. This action alleviates shift shock to the transmission.

KEY to fig. 1-18

- A Weight and spider assembly
- B Oil baffle
- C Torque link spring
- D Torque link
- E Guide
- F Sliding stop wedge
- G Smoke limit
- E Stop plate
- J Fulcrum lever assembly
- K Torque link pin
- L Contact surface
- M Operating shaft
- N Torque link pin
- P Contact surface

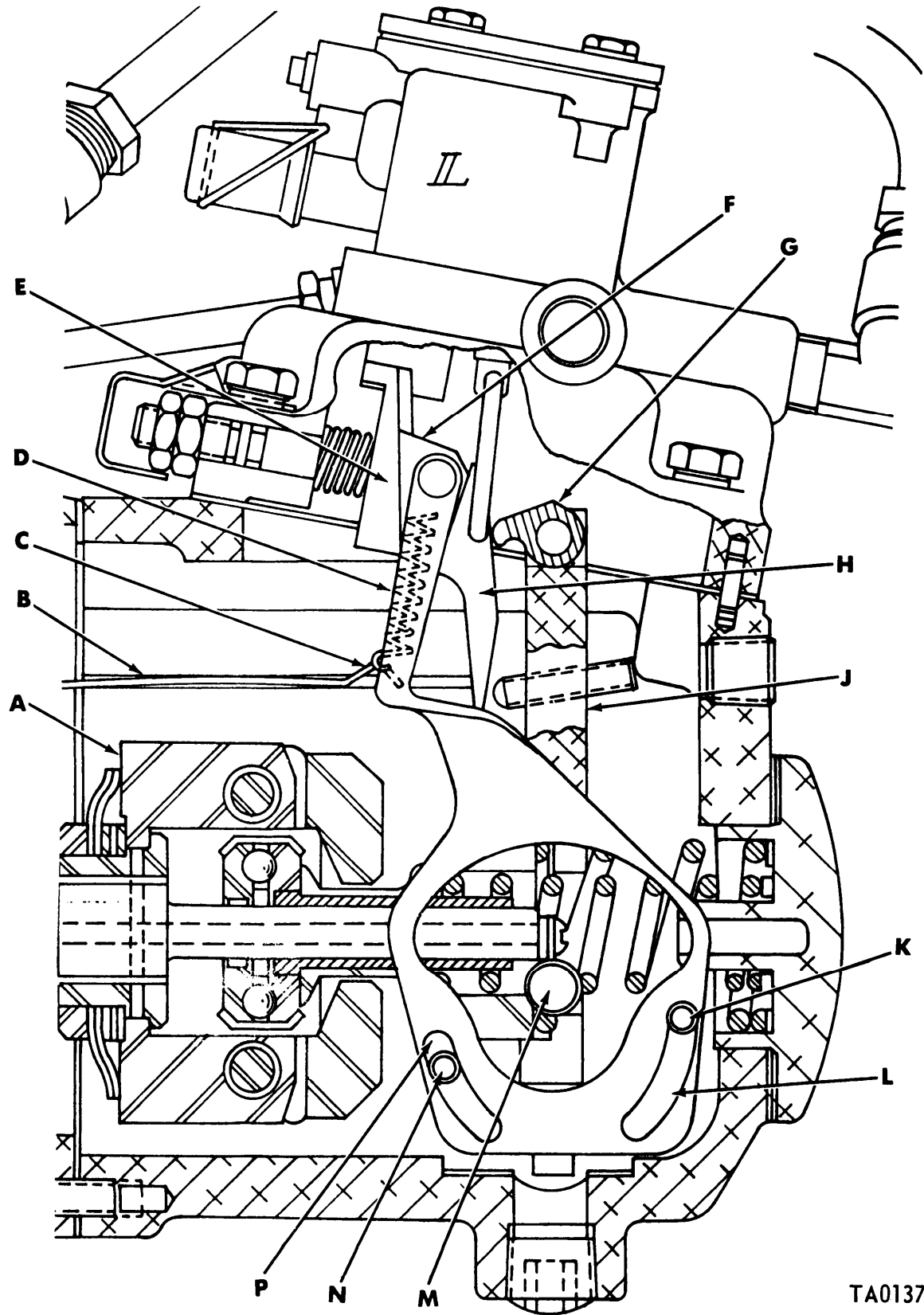

Figure 1-18. Governor assembly with torque link (code A), sectional view.

TA013712

b. The governor housing (TT) is attached to the of the injection pump housing (AC). The main components of the governor are the governor weight and spider assembly (UU, WW), sliding sleeve (VV), governor inner and outer springs (RR, SS), fulcrum lever (NN), and operating linkage.

c. The governor weight and spider assembly is pressed on an extension of the camshaft (ZZ) and contains two movable governor weights (UU) which are pinned on opposite sides of friction drive spider (WW). The weights swing freely on their pins.

d. The sliding sleeve moves freely on the camshaft and contains a thrust bearing against which the weight fingers bear. Each side of the sliding sleeve contains a slot to receive the pivot pins of the fulcrum lever. Counterbores at the rear of the sliding sleeve receive the governor inner and outer springs.

e. The smoke limit cam (MM) is located at the top of the fulcrum lever (NN) and rides on the stop plate (PP) of the density compensator. The operating lever (F, fig. 1-19 and 1-20) is connected to the operating shaft (E, fig. 1-19 and 1-20). The operating shaft is connected to the fulcrum lever by suitable linkage.

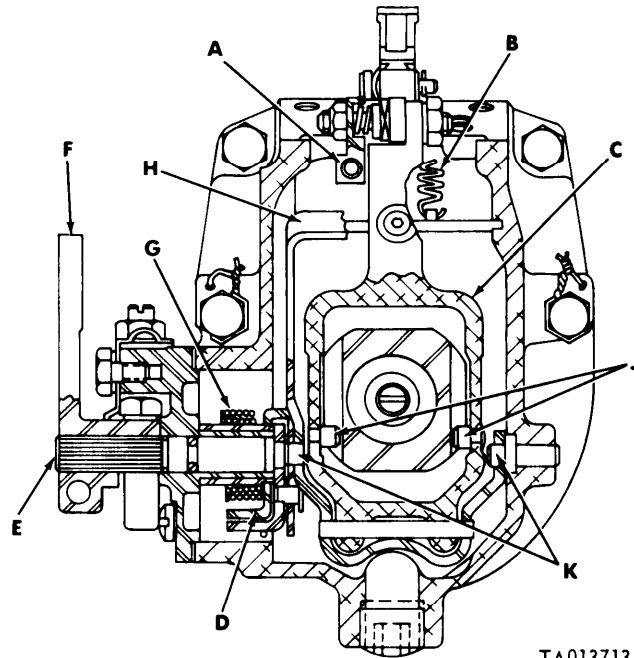

TA013713

- | | |
|----------------------|---------------------------|
| A Fuel control rod | F Operating lever |
| B Torque link spring | G Operating shaft spring |
| C Fulcrum lever | H Torque link |
| D Shaft spring plate | J Fulcrum lever pivot pin |
| E Operating shaft | K Yoke pivot pin |

Figure 1-20. Governor assembly (code A), rear sectional view.

1-14. Fuel Supply Pump Assembly (Code A and Early Code F Injection Pumps).

NOTE

The key letters shown below in parenthesis refer to figure 1-21.

a. The fuel supply pump assembly consists of the supply pump housing (B), camshaft driven gear (C), drive shaft (D), idler gear (E), housing cover (A), and check valve (G).

b. The supply pump housing contains inlet and outlet ports for the flow of fuel. It also houses the check valve which is held in place by the check valve spring (F) and valve screw (H).

c. The housing cover and cavity in the supply pump housing form a compartment in which the idler gear and drive shaft rotate. The cover also houses the relief valve (J) and spring (K).

d. Rotation is imparted by the fuel pump camshaft driven gear (C).

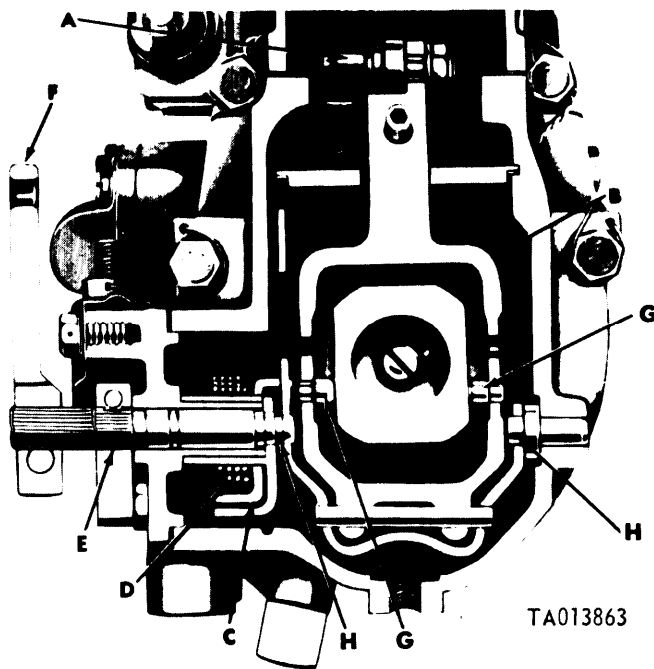

TA013863

- | | |
|--------------------------|---------------------------|
| A Fuel control rod | E Operating shaft |
| B Fulcrum lever | F Operating lever |
| C Shaft spring plate | G Fulcrum lever pivot pin |
| D Operating shaft spring | H Yoke pivot pin |

Figure 1-19. Governor assembly (code B, C, D, E, F and G), rear sectional view.

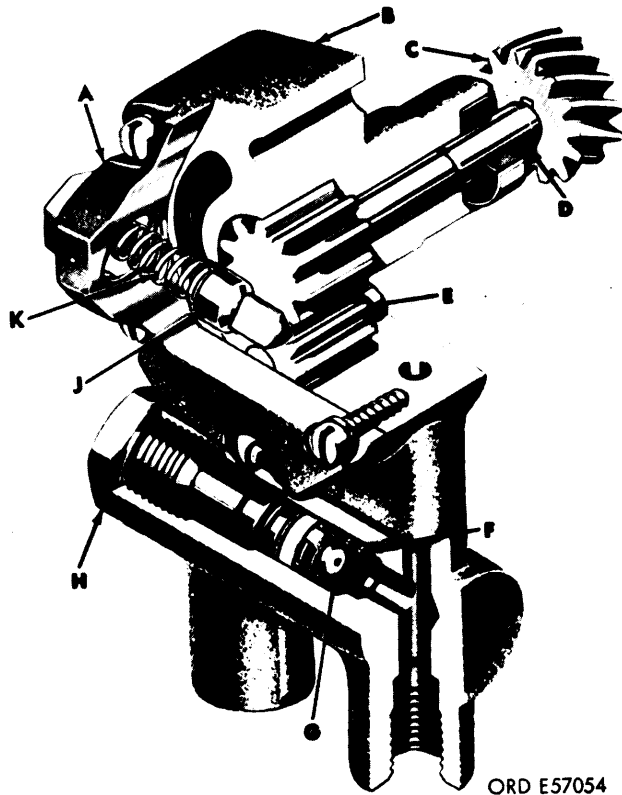

ORD E57054

- | | |
|------------------------|-----------------------|
| A Housing cover | F Check valve spring |
| B Supply pump housing | G Check valve |
| C Camshaft driven gear | H Valve screw |
| D Drive shaft | J Relief valve |
| E Idler gear | K Relief valve spring |

Figure 1-21. Fuel supply pump assembly (code A and F), sectional view.

1-15. Fuel Supply Pump Assembly (Code B, C, D, E, late F and G Injection Pumps).

NOTE

The key letters shown below in parentheses refer to figure 1-22.

a. The fuel supply pump assembly consists of the supply pump (B), camshaft driven gear (C), drive shaft (D), idler gear (E), housing cover (1), and check valve (G).

b. The supply pump housing contains inlet and outlet ports for fuel.

c. The housing cover and cavity in the supply pump housing form a compartment in which the idler gear and drive shaft rotate.

d. Rotation for the supply pump drive shaft (D) is imparted by the fuel pump camshaft through the camshaft driven gear (C).

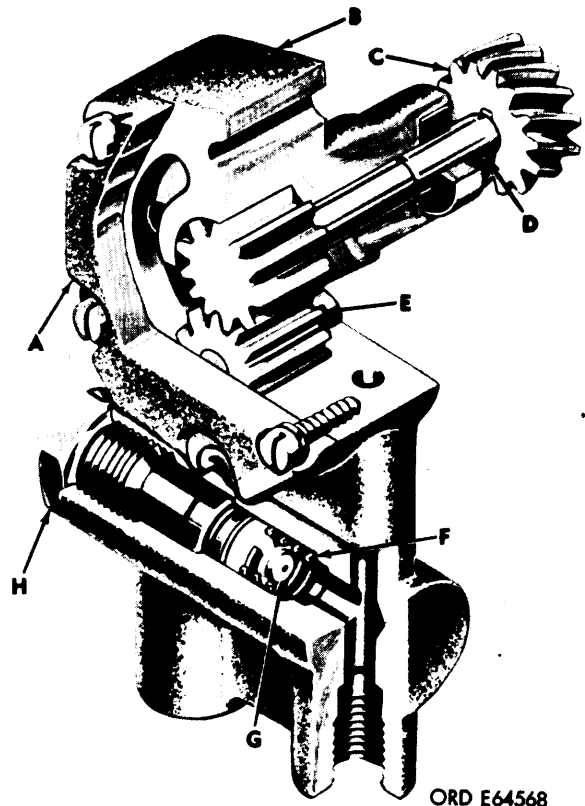

ORD E64568

- | | |
|------------------------|----------------------|
| A Housing cover | E Idler gear |
| B Supply pump housing | F Check valve spring |
| C Camshaft driven gear | G Check valve |
| D Drive shaft | H Valve screw |

Figure 1-22. Fuel supply pump assembly (code B, C, D, E, late F and G), sectional view.

1-16. Timing Device Assembly.

NOTE

The key letters shown in parentheses refer to figure 1-16.

a. The timing device housing (AD) is an aluminum casting with mounting flanges at both ends. A bore in the housing guides and supports the spider assembly (AH). A timing opening with cover (E) is located in the top of the housing and is used to observe the position of the timing pointer (D) and the timing mark on timing device hub (C) during enging and fuel pump timing.

b. The timing device hub (c), with external left hand helical splines for engaging the internal helical splines of the sliding gear (A), has a tapered bore and keyway. The hub is secured to the camshaft extension by a Woodruff key, nut, and setscrew. Old style hubs have a circular flange extending

diametrically from the fuel pump end of the hub and is channeled to receive the ends of the three timing device springs (B). The new style hubs do not have a flange and are counterbored to receive the timing device springs. The springs oppose the flyweight forces of the weight and spider assembly (AH).

c. The weight and spider assembly has external right hand helical splines to mesh with the internal helical splines of the sliding gear. The splined end is machined to receive the end play spacer (AE). Three flyweights are pinned to a flange adjacent to the splines. The weight and spider thrust plate (AG), located between the flange and the timing device housing, carries the back-thrust of the flyweights and prevents housing wear.

d. The sliding gear has internal left hand helical splines at one end and internal right hand helical splines at the other end and meshes with the external splines of both the weight and spider assembly and the timing device hub. Correct assembly of the spline train is insured by a wide land on both the hub and weight and spider assembly. The sliding gear has a missing tooth on each set of internal splines to receive the wide lands. Three arms extend from the outer surface of the sliding gear and provide seats for the three timing device springs. The force on the springs is controlled by a sliding gear spacer (AF).

1-17. Fuel Density Compensator (Code F Injection Pump).

NOTE

The key letters shown below in parentheses refer to figure 1-15.

a. The diaphragm housing (BB) is attached to the top of the governor housing and contains the stop plate (PP), guide (AA), inlet housing diaphragm (LL), and related parts.

b. The fuel inlet housing (DD) attaches to the diaphragm housing and contains the fuel inlet port (JJ) and pressure regulator valve (HH).

c. The pressure regulator valve (HH) is adjusted by the use of shims. This valve determines the inlet fuel pressure.

d. The fuel outlet housing (EE) attaches to the fuel inlet housing and contains a fuel outlet port (GG) and an adjustable servo pressure valve (FF). The fuel outlet housing also has a recess for the servo spring (CC).

e. The servo pressure valve (FF) is adjusted during calibration of the density compensator to provide the correct fuel pressure drop across the inlet housing diaphragm (LL), establishing the stop plate (PP) travel.

f. The stop plate guide (AA) provides adjustment of the fulcrum lever in the injection pump.

g. The guide bears against the stop plate (PP) which, in turn, contacts the smoke limit cam (MM). The guide can be adjusted to move the stop plate laterally, thereby regulating travel of the governor fulcrum lever (NN).

1-18. Fuel Density Compensator (Code B, C, D and E Injection Pumps).

NOTE

The key letters shown below in parentheses refer to figure 1-16.

a. The density compensator housing (BB), and gasket (Y) are attached to the top of the governor housing.

b. The compensator housing cover (EE) and housing cover gasket (FF) enclose the servo spring (GG) and the servo pressure well.

c. The pressure regulating valve (JJ) is adjusted by the use of shims. This valve determines the servo system inlet fuel pressure.

d. The fuel outlet is through an elbow at the right front of the housing connected by a tube to the fuel injection pump overflow valve tee.

e. The servo pressure valve (CC) is adjusted during calibration of the density compensator to provide the correct fuel pressure on the piston (H H) and establish the travel of the stop plate (PP).

f. The stop plate guide (AA) provides adjustment of the fulcrum lever in the injection pump.

g. The guide bears against the stop plate (PP) which, in turn, contacts the smoke limit cam (MM). The guide can be adjusted to move the stop plate laterally, thereby regulating the travel of the governor fulcrum lever (NN).

1-19. Fuel Density Compensator (Code A Injection Pump).

NOTE

The key letters shown below in parentheses refer to figure 1-17.

a. The density compensator housing (BB) and gasket (Y) are attached to the top of the governor housing.

b. The compensator housing cover (EE) and housing cover gasket (FF) enclose the servo spring (GG) and the servo pressure well.

c. The pressure regulating valve (JJ) is adjusted by the use of shims under the plug at the spring end of the valve. The valve determines the servo system inlet fuel pressure.

d. The fuel outlet is through an elbow at the right front of the housing connected by a tube to the fuel injection pump overflow valve tee.

e. The servo pressure valve (CC) is adjusted during calibration of the density compensator to provide the correct fuel pressure on the piston (HH) and establish the travel of the stop plate (PP).

f. The stop plate guide (AA) provides adjustment of the fulcrum lever in the injection pump.

g. The guide bears against the sliding stop weight (AK) and stop plate (PP) which, in turn, contacts the smoke limit cam (MM). The guide can be adjusted to move the stop plate laterally, thereby regulating the travel of the governor fulcrum lever (NN).

1-20. Operation. The operation is described in relation to oil lubrication, fuel flow, fuel pumping and distribution, fuel metering and control speed governing, fuel density compensating, and timing advancement.

1-21. Oil Lubrication.

NOTE

The key letters shown in parentheses refer to figure 1-23 except where otherwise indicated.

a. Oil enters under pressure from the engine at the pipe-to-tube tee (fig. 1-1) and flows to the timing device housing and through the oil hose assembly to the injection pump housing bushing type bearings (L). The remaining internal parts of the advance unit assembly are splash lubricated by oil in the advance unit housing oil sump (K).

b. On code A, B, C, D, and E injection pumps, oil entering the injection pump housing flows up the main oil passage (D) to lubricate the tappet assembly (E).

c. Code F and G injection pumps have an additional oil passage. Oil entering the injection pump housing flows up the main oil passage (D) to the oil filter (C). Filtered oil flows to the lower section of the fuel plunger (A) and to the gear thrust washer (B). Oil flows from the main passage (D) to lubricate the tappet assembly (E).

d. A hole in the camshaft bushing type bearing (J) allows oil to flow from the main oil passage to lubricate the camshaft journal. A passage in the journal allows oil to flow through the camshaft oil passage (H). There are no oil passages in the friction drive spider. The weight pins are equipped with nylon type bearings which do not require lubrication. Oil flows through the camshaft oil port (F) to lubricate the sliding sleeve.

e. The camshaft lobes, camshaft ball bearing, quill shaft drive gears and internal governor parts are splash lubricated by oil collected in the bottom of the injection pump. Oil drains back from the governor housing and pump housing through the timing device housing and returns to the engine crankcase.

f. Code F injection pumps may have an additional oil drain (G) on the governor housing that returns oil through an external line to the oil pan.

g. Early code G injection pumps have an oil passage (M) through the camshaft and friction drive spider to governor weight pins and bronze bushings. Later code G pumps have teflon bushings and do not require this lubrication.

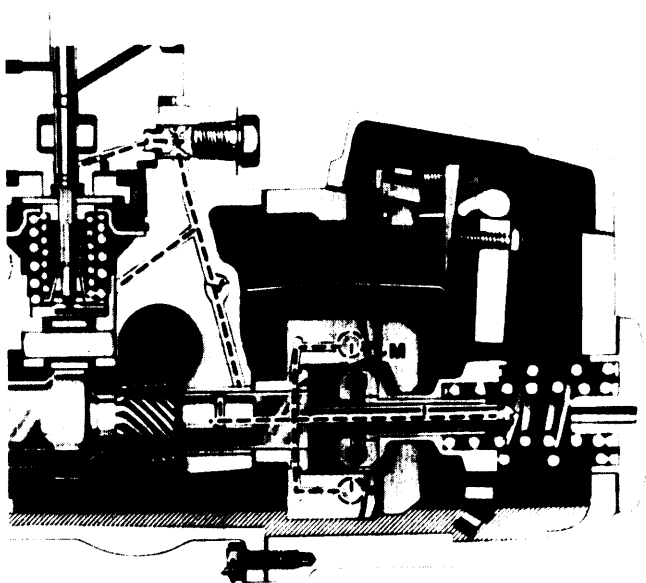

GOVERNOR WEIGHT OIL PASSAGE
(CODE G AND EARLY CODE F PUMP)

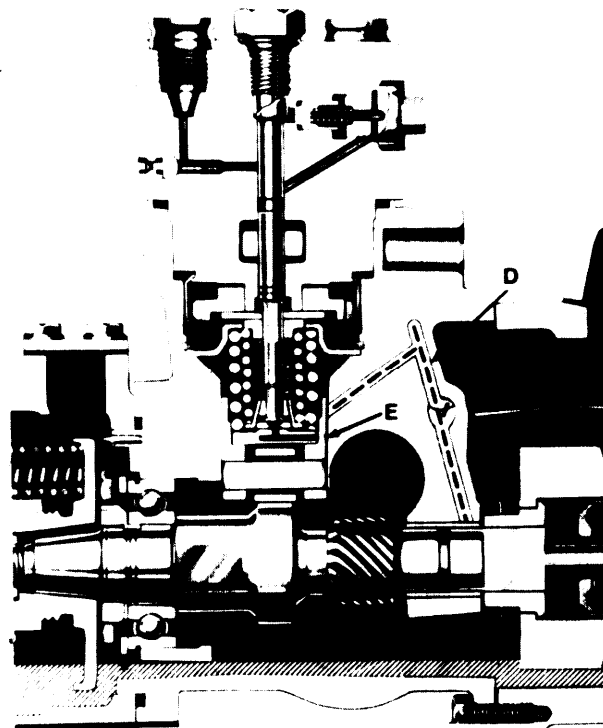

PUMP HOUSING OIL PASSAGE
(CODE A, B, C, D, E AND LATE F PUMPS)

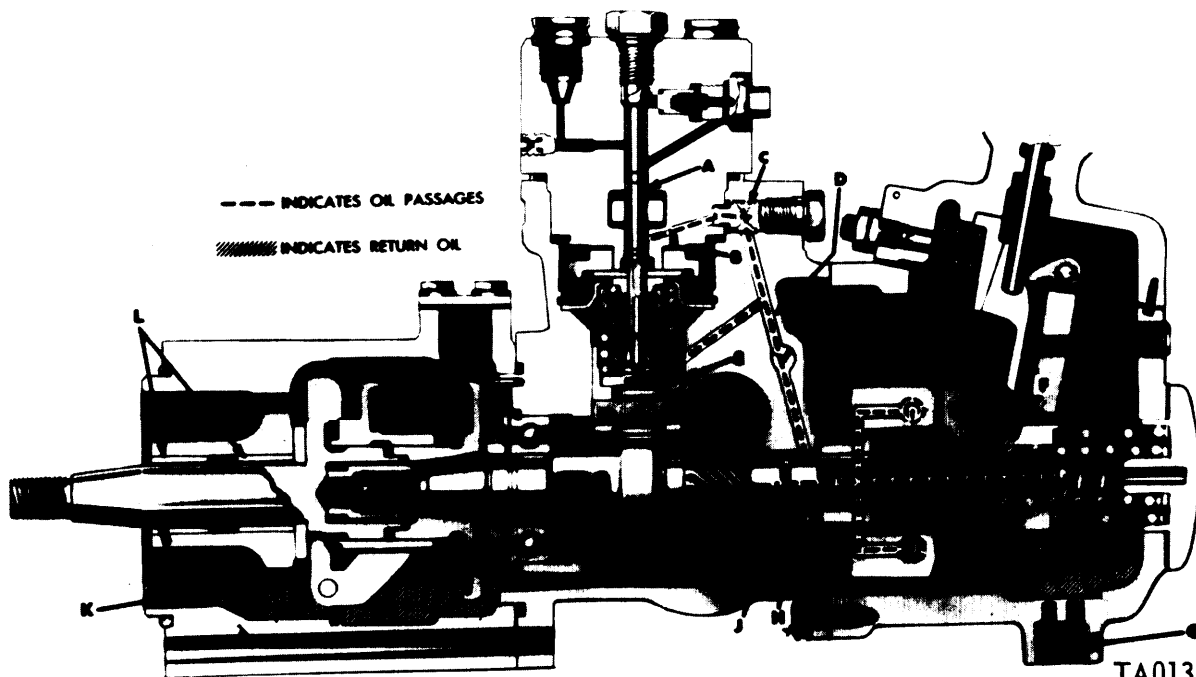

TA013801

- A Fuel plunger
- B Gear thrust washer
- C Oil filter
- D Main oil passage
- E Tappet assembly
- F Camshaft oil port

- G Oil outlet to oil pan
- H Camshaft oil passage
- J Camshaft bushing type bearing
- K Timing device housing oil sump
- L Housing bushing type bearing
- M Governor weight oil passage (code G pumps).

Figure 1-23. Lubrication oil flow diagram (typical), side view.

1-22. Fuel Flow. Fuel flows from the vehicle fuel tank to the fuel supply pump inlet. The fuel supply pump delivers fuel through the fuel filters to a tee installed in the fuel density compensator inlet port. From the tee, fuel flows to the density compensator and to the inlet of the hydraulic head. Fuel flows through the hydraulic head and the head outlets to the engine cylinders. Excess fuel from the hydraulic head passes through the overflow valve, which maintains a constant fuel pressure in the hydraulic head. The constant flow of fuel through the hydraulic head not only supplies fuel for injection but also serves as a coolant for the hydraulic head. A pressure regulator valve (JJ, fig. 1-16) in the density compensator maintains pressure at 20 to 21 psi. Excess fuel from the density compensator and hydraulic head flows back to the vehicle fuel tank.

1-23. Fuel Pumping and Distribution. *a.* The fuel injection pump camshaft is driven at engine crankshaft speed. As the camshaft rotates, the tappet moves the fuel plunger (U, fig. 1-16) up and down. The quill shaft, driven off the camshaft, drives the plunger drive gear which rotates the fuel plunger. When the camshaft has rotated twice, the fuel plunger has rotated 360° and completed six fuel injection strokes.

b. At the intake phase (fig. 1-24), the fuel plunger is on the base circle of the camshaft, the fuel plunger is down, and fuel enters the pressure chamber. As the camshaft rotates, the fuel plunger closes off the inlet and outlet ports and is at the beginning of delivery phase (fig. 1-25). The fuel in the pressure chamber is pressurized and starts to open the fuel delivery valve. At the delivery phase (fig. 1-26) the fuel is under sufficient pressure to fully open the fuel delivery valve. This highly pressurized fuel then flows around the fuel plunger annulus, through the distributing slot, which is now aligned with one of the six outlet passages, and out the outlet passage to the injector nozzle. At the end of delivery phase (fig. 1-27), after sufficient upward movement of the fuel plunger, the spill passages passes over the edge of the plunger sleeve. The fuel pressure then escapes down the plunger vertical fuel passage into the fuel sump which is at supply pressure. The reduction of pressure causes the fuel delivery valve to close.

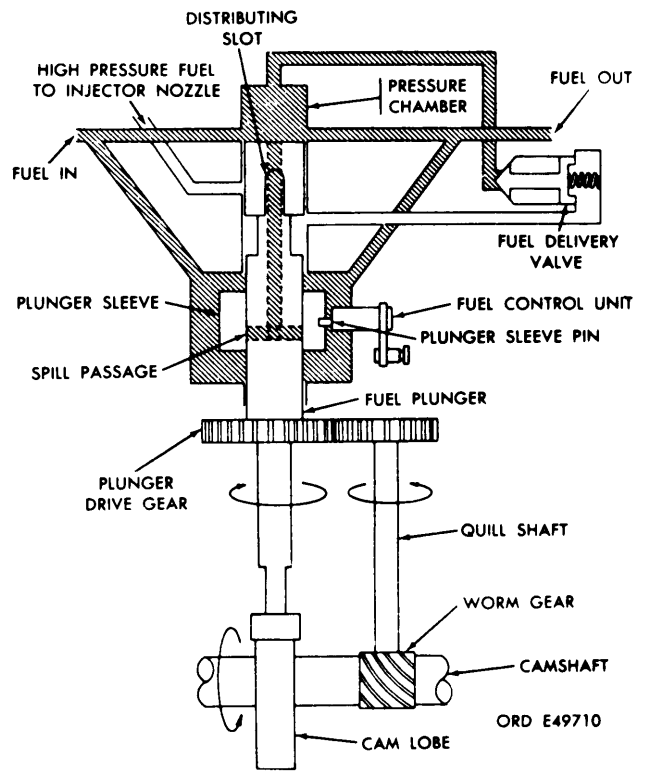

Figure 1-24. Fuel intake flow diagram.

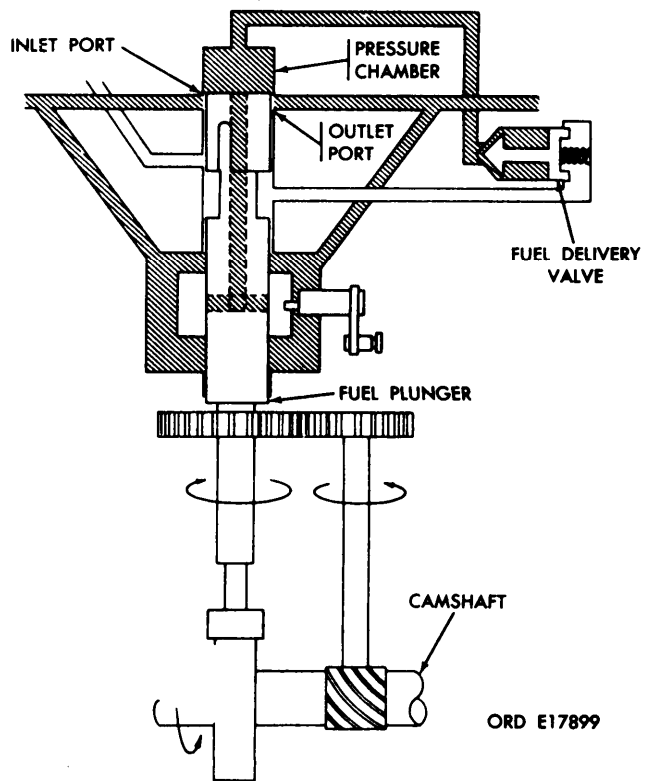

Figure 1-25. Beginning of fuel delivery flow diagram.

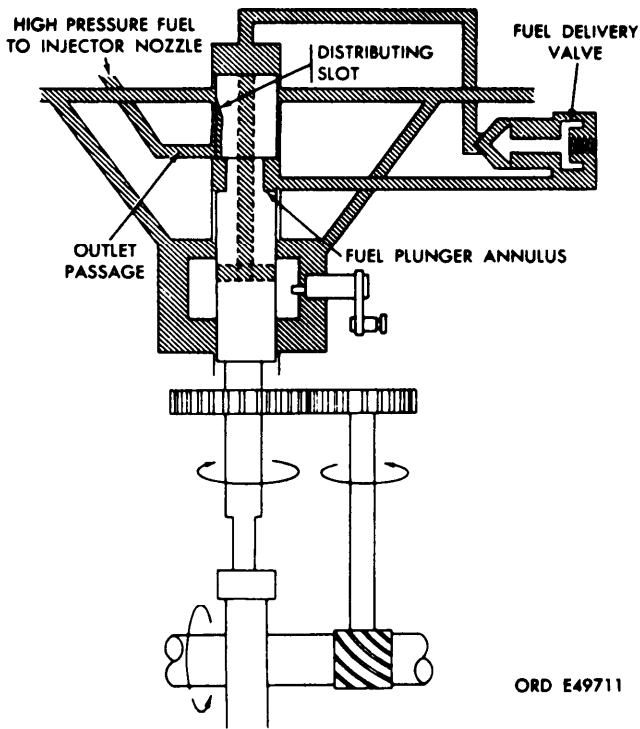

Figure 1-26. Fuel delivery flow diagram.

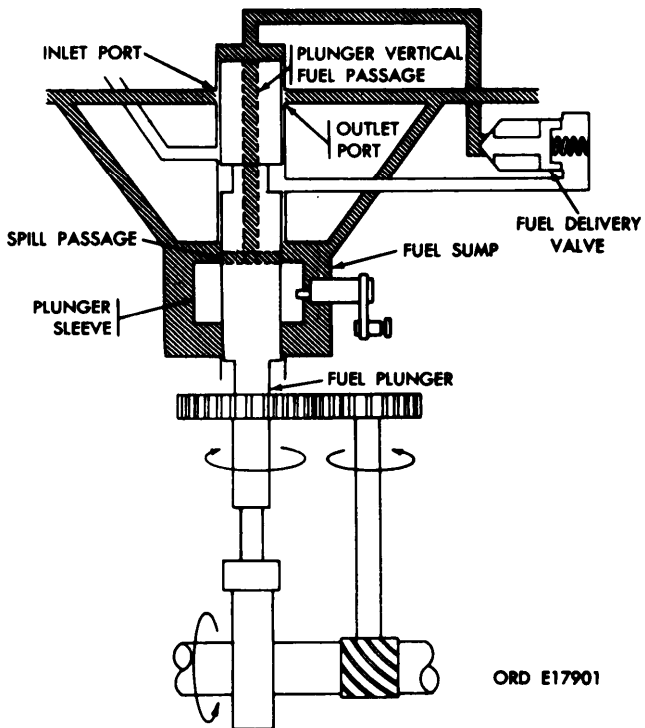

Figure 1-27. End of fuel delivery flow diagram.

1-24. Fuel Metering and Control. *a.* The quantity of fuel delivered per stroke is governed by variation in the position of the plunger sleeve (fig. 1-27) with relation to the fixed port closing position (the point at which the top of the fuel plunger covers the fuel

ports). As the spill passage in the fuel plunger breaks over the top edge of the plunger sleeve, pumping pressure is relieved and fuel delivery terminates despite continued upward movement of the fuel plunger.

b. When the plunger sleeve is raised, the spill passage remains covered by the plunger sleeve until relatively late in the plunger stroke. Hence, the effective stroke of the fuel plunger is longer and more fuel is delivered. When the plunger sleeve is lowered the spill passage is uncovered by the plunger sleeve relatively sooner in the plunger stroke. Hence, the effective stroke of the fuel plunger is shorter and less fuel is delivered.

c. When the plunger sleeve is lowered to its extreme point, the spill passage is uncovered by the top edge of the plunger sleeve before the upper end of the fuel plunger can cover the fuel ports. Under this condition, no pressure can be built up and no fuel can be delivered. This is the fuel shutoff position.

1-25. Speed Governing (Typical).

NOTE

The key letters shown below in parentheses refer to figure 1-19 except where otherwise indicated.

a. The camshaft has two forged governor weights (UU, fig. 1-16) attached to it through pins in a spider. As camshaft speed increases, the weights move outward away from the camshaft. Fingers on the weights act against the sliding sleeve (VV, fig. 1-16).

b. The sliding sleeve is compressed against the fingers of the governor weights by the governor inner and outer springs (RR and SS, fig. 1-16). The tensions of these springs balance the action of the governor weights at any given speed within the normal range after the sliding sleeve has shifted. Therefore, at any given engine speed, there is a definite corresponding sliding sleeve position.

c. The sliding sleeve is connected to the fulcrum lever (B) through pivot pins (G, fig. 1-19). The fulcrum lever slides in grooves in the sliding sleeve and as the sliding sleeve moves, the fulcrum lever moves. The fulcrum lever is also connected through linkages to the plunger sleeve in the hydraulic head. - As noted in paragraph 1-23 above, the position of the plunger sleeve determines the quantity of fuel delivered.

d. The fulcrum lever is also pivoted (H, fig. 1-19) at its lower end on a yoke (an integral part of the fulcrum lever) which is connected to the operating shaft (E). The operating lever (F), which connects to the operating shaft, is actuated through linkage from the vehicle driver's compartment. The position of the operating lever determines fuel delivery and engine speed.

e. With the operating lever in a stationary position, the lower pivot of the fulcrum lever becomes fixed. If the engine load is increased, the engine speed will momentarily decrease and the governor weights will lack the centrifugal force necessary to balance the spring forces on the sliding sleeve. The fulcrum lever then shifts and moves the

plunger sleeve toward increased fuel delivery. The engine then increases to original speed.

f. If engine load is decreased, the speed will momentarily increase and the governor weights will move further out. The fingers on the weights shift the sliding sleeve against the opposing spring forces. The fulcrum lever shifts and moves the plunger sleeve toward decreased fuel delivery, reducing engine speed.

g. The operating shaft is connected to the fulcrum lever by the shaft spring plate (C) and operating shaft spring (D). The fork on the upper portion of the shaft spring plate engages the fulcrum lever. The operating shaft spring grips the tang on the spring plate and the tang on the operating shaft. This torsion spring loads both tangs toward each other so that normally the operating lever and fulcrum lever act as though rigidly attached. When engine speed differs as a result of load changes, from the normal to the operating lever position, the tangs part momentarily until the governor senses the change. This function protects the governor and fuel injection pump parts from unnecessary high loads and stresses.

NOTE

The key letters shown below in parentheses refer to figure 1-18.

The functioning of the torque link assembly applies only to code A-injection pumps. As the torque link (D) moves upward, the fuel stop wedge (F) moves upward to an increased fuel delivery. As it moves downward the fuel delivery decreases.

h. The principle function of the torque link assembly is to control the sliding stop wedge (F) and its movement up and down. Due to its wedge configuration, as it moves up it moves the stop plate (H) forward allowing the smoke limit cam (G) to move to an increased fuel position. As it moves downward it moves the stop plate toward the rear of governor housing or a decreased fuel position. The torque link assembly limits maximum fuel quantity at any position of the operating shaft assembly other than the full-load position or low-idle position of the operating shaft assembly.

i. When the operating shaft assembly is in the full-load position the torque link assembly is in the full-load quantity position. Pin (K) has contacted surface (L) of kidney slot and raised the torque link assembly to its maximum upward travel position. As the operating shaft assembly is moved away from the full-load position the torque link assembly moves downward resulting in decreased fuel. At an intermediate operating shaft position, the spring (C) moves stop wedge (F) downward to a position where both pins come in contact with the torque link

assembly. This position represents maximum fuel limiting effect. In the low-idle position, pin (N) has contacted surface (P), and raised the torque link assembly. This provides maximum fuel delivery for engine starting. The purpose of above operations is to protect the engine and automatic transmission from excessive load changes during shifting, while maintaining power at full load and providing sufficient starting fuel quantities.

1-26. Timing Advancement.

NOTE

The key letters shown below in parentheses refer to figure 1-16.

As the engine speed rotates the weight and spider assembly (AH), centrifugal force opens the flyweights from their collapsed position. The loading of the three timing device springs (B) acts against the flyweights until a certain engine speed is reached, at which point the forces of springs and flyweights are balanced. As engine speed increases, the flyweights swing out and force the sliding gear (A) toward the timing device hub (C). As a result of this longitudinal and axial movement of the sliding gear, the metering and distributing pump camshaft is rotated slightly out of phase and in advance of the weight and spider. The axial movement of the sliding gear is caused by the internal helical splines of the sliding gear acting on the external helical splines of the weight and spider and the timing device hub (para 1-16). Therefore, the timing of the fuel pump with relation to the top dead center position of the engine's piston is advanced within a given range.

1-27. Fuel Density Compensating (Typical). *a.* The multifuel engine operates on fuels having a significant variation in density and heat value per gallon. These variations in the fuels affect engine output. Any power loss due to a change of fuel is not acceptable. The fuel density compensator on the fuel injection pump automatically varies the quantity of fuel delivered to the engine to maintain a constant maximum power output regardless of the fuel being used.

b. The characteristics of the fuels used in the engine show a definite relationship between viscosity and heating value. The fuel density compensator takes this into consideration by making the viscosity characteristic a sensed variable. In the compensator the fuel is passed in series through two orifices of widely different flow characteristics. A change in viscosity of the fuel flowing through these orifices causes a pressure drop change which moves a servo diaphragm (fig. 1-28) or piston (fig. 1-29) to vary the full-load stop of the fuel injection pump.

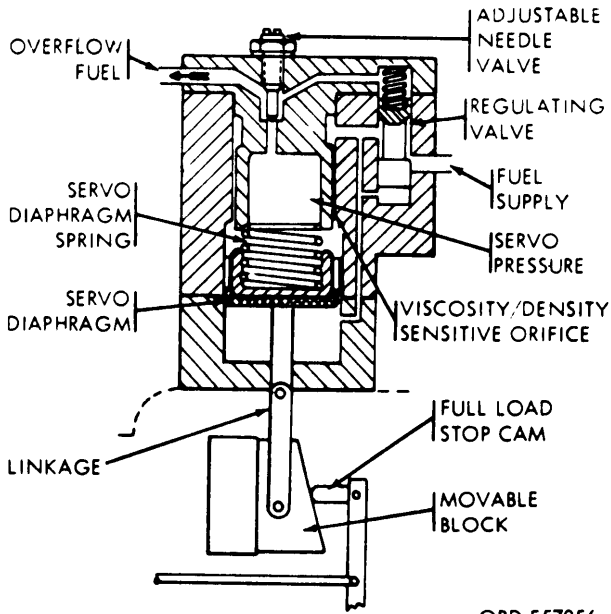

ORD E57056

Figure 1-28. Fuel density compensator (early code F), sectional view.

c. The fuel supply is admitted to a pressure regulating valve where the supply pressure is reduced to a constant regulated pressure over the engine operating speed and load range. Fuel flows through the first (viscosity/density sensitive) annular orifice formed by a close fitting piston in a cylinder. From the servo pressure cylinder the fuel flows to the second orifice which is a sharp-edged, adjustable needle valve. The two orifices working at widely different restrictions to the flow of fuel form a system sensitive to viscosity changes. The pressure difference between the two orifices will change the servo pressure in direct relationship to the viscosity of the fuel flowing. The position of the spring-loaded servo diaphragm (fig. 1-28) or servo piston (fig. 1-29) is varied in accordance with these servo pressure drops.

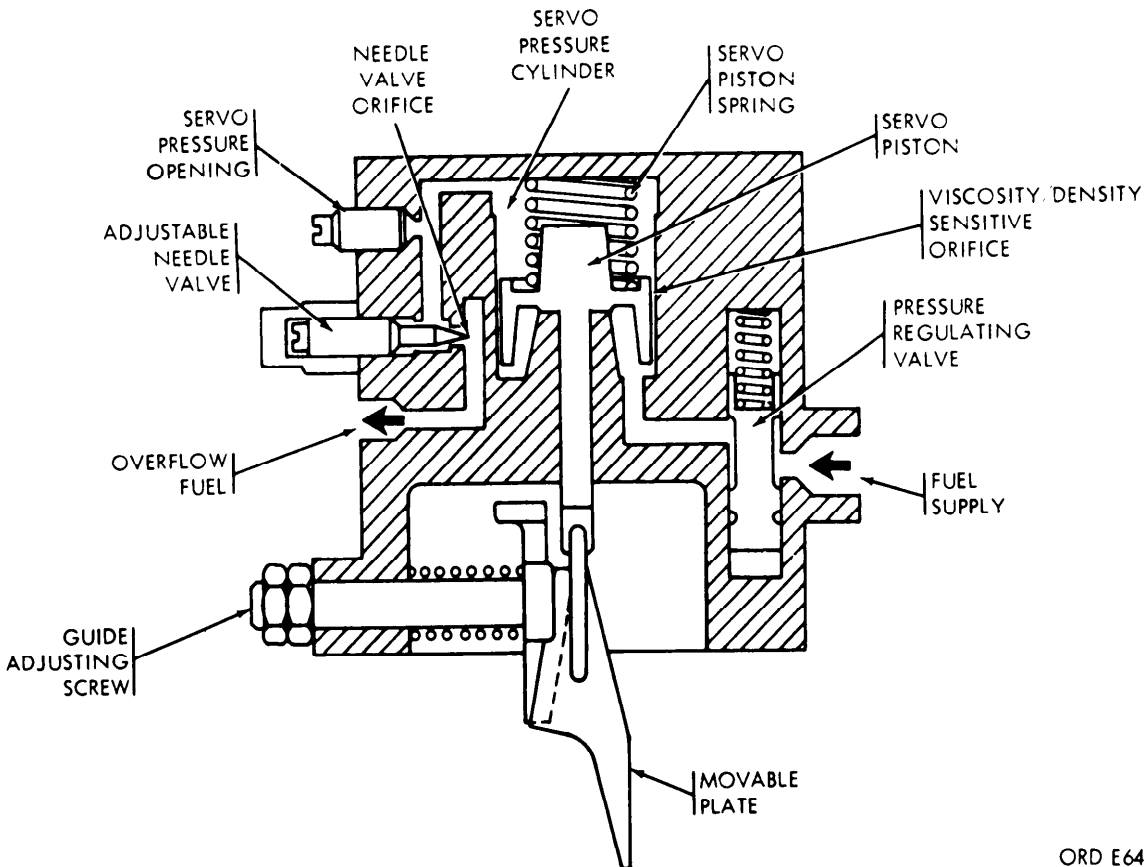

ORD E64569

Figure 1-29. Fuel density compensator (code A, B, C, D and E) sectional view.

d. At any position of equilibrium the spring load plus the servo pressure is equal to regulator pressure. The diaphragm (fig. 1-28) or piston (fig. 1-29) is connected by linkage to a wedge-shaped movable block which serves to vary the position of the full-load cam in the injection pump. Proper selection of the full-load stop wedge angle and servo diaphragm or piston spring rate produces the amount of compensation required to maintain constant power output over a range of fuels.

e. These fuel density compensators are manufactured to provide the fuel compensation for the multifuel engines. Each fuel injection pump must be constructed for the particular engine for which it is designed.

f. Code G injection pumps are not equipped with a fuel density compensator. They have a stationary stop plate and bridge assembly attached to the governor housing (fig. 1-30). The stop plate and bridge assembly accomplishes the same function as the compensator stop plate except it does not compensate for various viscosity fuels.

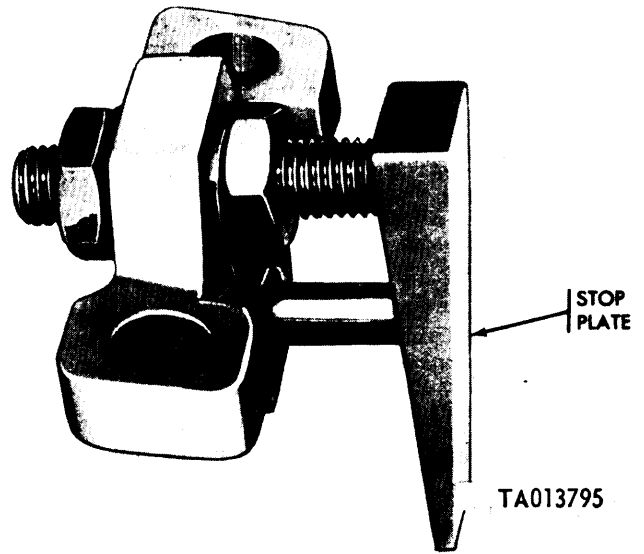

Figure 1-30. Stop plate and bridge assembly (code G).

1-28. Fuel Injection Pump Data.

Manufacturer	American Bosch Division	
Model PSB-6A	
Length. 17.75 in. (approx)	
Width. 6.50 in. (approx)	
Height:		
2910-178-1185 (code A). 11.50 in. (approx)	
2910 -759 -5419 (code Canal D). 11.50in. (approx)	
2910 -103 -2644 (code E) 11.50 in. (approx)	
2910-017-9778 (early code F). 12.87 in. (approx)	
2910-908-6320 (code Band late code F) 11.50in. (approx)	
2910-860-2333 (early code G) 9.7in. (approx)	
2910-968-6317 (late code G). 9.7 in. (approx)	
Name plate location.	Top left side of governor housing	
Mounting data:		
Number of mounting holes 3	
Diameter mounting holes 0.406	
Governor speed range (on DF-1 fuel):		
	<i>Idle</i>	<i>Full load</i>
2910-178-1185 (code A)	650-700	2800
2910-759-5410 (code C and D).	650-700	2600
2910-103-2644 (code E)	650-700	2600
2910-017-9778 (early code F)	650-700	2600
2910-908-6320 (code Band late code' F)	650-700	2600
2910-860-2333 (early code G).	550-600	2800
2910-968 -6317 (late code G)	550-600	2800
Rotation (viewed from drive end) Clockwise	
Fuel injection sequence. 1, 5, 3, 6, 2, 4	
Delivery valve opening pressure 250-400 psi	
Overflow pressure. 5 psi max.	
Fuel pressures, minimum (after final filter):		
700 RPM 30 psi min.	
2600 RPM 60 psi min.	
Fuel density compensate (all except 2910-860-2333 and 2910-968-6317 pumps):		
Pressure regulator valve setting (all fuels) 20-21 psi	

1-29. Differences Between Injector Pumps. Table 1-1 lists the major differences between the pumps used on the various engines. An X in the column indicates the item in the description column is used on that particular pump.

Table 1-1. Difference between Models

Part Description	Engine						
	Code	LDS-465-2	LDS-465-1A	LD-465-1	LDT-465-1C	LDS-465-1	LDS-427-2
1. Fuel supply pump with fuel pressure relief valve.	X					X	
2. Engine mounted fuel filters after fuel supply pump:							
a. 2 filters	X	X	X	X	X		X
b. 1 filter						X	
3. Fuel density compensator type:						X	
a. Diaphragm						X	
b. Piston	X	X	X	X	X		
4. Fuel line type:							
a. Hose						X	X
b. Plastic tubing	X	X	X	X	X	X	X
5. Oil filter in pump housing.						X	X
6. Throttle operating lever type:							
a. 1 piece		X	X	X	X	X	X
b. 2 piece	X						
7. Overflow valve body orifice at fuel inlet seal, inside diameter:							
a. 0.280 (approx)	X	X	X	X	X		X
b. 0.085 (approx)						X	
8. Fulcrum lever assembled with low speed fuel adjusting setscrew (droop screw).	X	X			X	X	X
9. Governor equipped with torque control link for automatic transmission application.	X						
10. Governor housing oil drain to oil pan by external hose.						X	
11. Fuel shutoff type:							
a. Manual		X	X	X	X	X	X
b. Electrical	X						
12. Throttle lever mounting position:							
a. Up	X						X
b. Down		X	X	X	X	X	
13. Governor speed range:							
a. 700-2600		X	X	X	X	X	
b. 700-2800	X						
c. 600-2800							X
d. 800-2600					X		
14. Timing device spring rates:							
a. 69.0 lbs/in. (SP9041).		X				X	X
b. 55.1 lbs/in. (SP9043).				X			
c. 102.5 lbs/in. (SP857-3).	X						

CHAPTER 2

DIRECT SUPPORT AND GENERAL SUPPORT MAINTENANCE INSTRUCTIONS

Section I. REPAIR PARTS, SPECIAL TOOLS, AND EQUIPMENT

2-1. General. Special tools, equipment and maintenance parts over and above those available to the using organization are supplied to direct support and general support maintenance units for maintaining and repairing the fuel injection pump.

2-2. Repair Parts. Repair parts for the metering and distributing fuel injection pump are listed in appendix B.

2-3. Common Tools and Equipment. Standard and commonly used tools and equipment having general application to this material are authorized by tables of allowances (TA) and table of organization and equipment (TOE).

2-4. Special Tools and Equipment. The special tools illustrated in figure B-10 and listed in table 2-1 are

those tools necessary to perform operations described in this manual.

2-5. Improvised Tools. Refer to figure 2-1 which illustrates an improvised tool used for setting the smoke limit cam angle.

Tool Dimensions

<i>Tool</i>	<i>Gap</i>	
	<i>Outer</i>	<i>Inner</i>
1	0.030	0.110
2	0.040	0.110
3	0.050	0.110

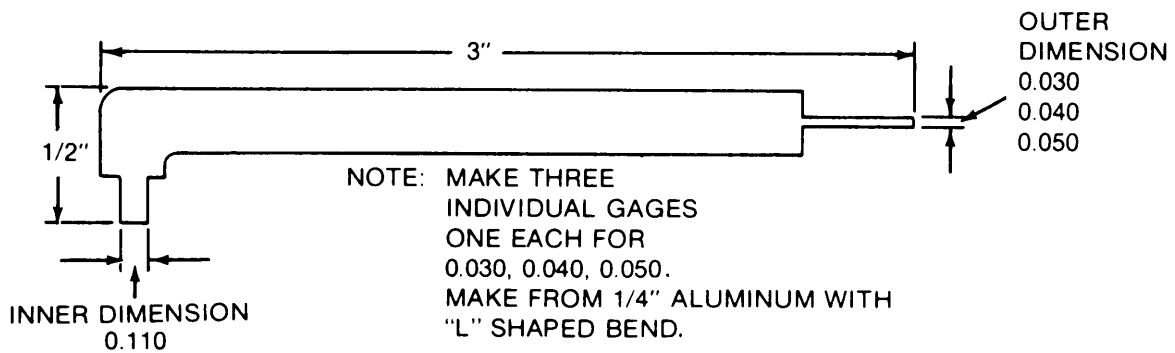
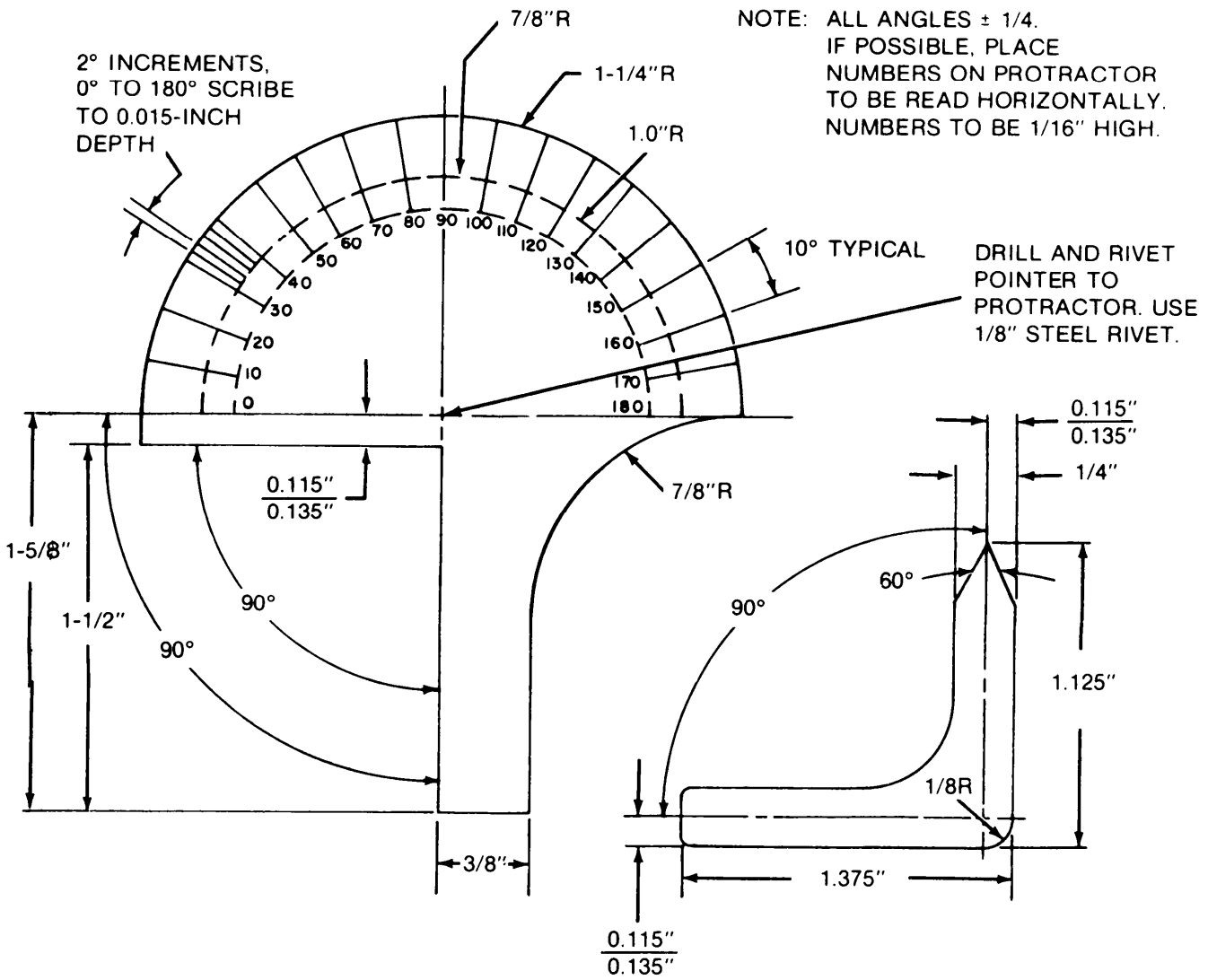

TYPICAL IMPROVISED INNER & OUTER GOVERNOR SPRING GAGE

TA013714

Figure 2-1. Improvised Tools.

Table 2-1. Special Tools

Item	Identifying No.	Reference		Use	Fig.
		Fig.	Para		
COMPRESSOR, spring	5120-870-9625 (10899170)	3-23	3-14b	Removing and installing spring retaining ring.	B-10
FIXTURE, camshaft holding	4910-870-2131 (10899172).	3-121	3-12b	Positioning camshaft.	B-10
		3-16			
		3-22			
		3-114			
FIXTURE, pump holding	4910-870-2128 (20899198).	3-126	3-13	Holding metering and distributing pump for disassembly and assembly.	B-10
		3-21			
		3-112			
		3-113			
GAGE, spring gap	4910-793-5040 (20882854).	3-125	3-144	Adjusting governor inner and outer spring gap.	B-10
		3-145			
PULLER, mechanical	5120-793-5048 (10882818).	3-14	3-11	Removing weight and spider assembly.	B-10
		3-18	3-12	Removing advance unit hub.	
REMOVER AND REPLACER internal components.	5120-793-5055; (10882856).	3-14	3-11	Removing and installing weight and spider assembly, camshaft, and camshaft ball bearing. Installing camshaft ball bearing on camshaft.	B-10
		3-28	3-16		
TEMPLATE, throttle arm adjustment.	5120-134-7462; (11642005).	3-175	3-58	To adjust throttle lever position.	B-10
WRENCH, ball bearing retaining lock nut.	5120-870-6926 (10899169).	3-106	3-31	Removing and installing ball bearing retaining locknut.	B-10
WRENCH, spring disk adjusting nut.	5120-793-5046 (10882889).	3-90	3-26	Removing and installing spring disk adjusting nut on fuel pump assembly, 7748899.	B-10

Section II. TROUBLESHOOTING

2-6. Purpose. *a.* Information in this section is for use of maintenance personnel in conjunction with, and as a supplement to the troubleshooting sections in the pertinent vehicle and engine technical manuals. It provides continuation of instructions where a remedy in the above technical manuals refers to maintenance personnel for corrective action.

b. Operation of a deadlined vehicle without a preliminary examination can cause further damage to a disabled fuel injection pump and possible injury to personnel. By careful inspection and troubleshooting, such damage and injury can be avoided and, in addition, the cause of faulty operation of a vehicle or fuel injection pump can often be determined without extensive disassembly.

2-7. General Instructions and Procedure. This section contains inspection and troubleshooting procedures to be performed after a fuel injection pump has been removed from the vehicle and/or power plant.

a. Inspection after the fuel injection pump is removed from the vehicle and/or engine is performed to verify any diagnosis made when the pump was in the vehicle, to uncover further defects, or to determine any malfunction if the component alone is received by the maintenance activity. This inspection is particularly important in the last case

because it is often the only means of determining the malfunction without disassembling the fuel injection pump.

b. Troubleshooting a disabled fuel injection pump after it has been removed from the vehicle and/or engine consists of subjecting it to tests on a suitable test stand. This section discusses those symptoms which can be diagnosed by using the testing equipment and interprets the results in terms of probable causes. Information pertaining to this test is contained in paragraphs 3-49 through 3-52.

2-8. Procedures. After a metering and distributing fuel injection pump has been received by the maintenance activity for preliminary inspection, or if performance of the pump has been unsatisfactory due to unknown causes, it must be checked before installing it on a test stand. This check should include a search for any binding or broken parts by rotating camshaft and operating lever. When cause for failure has been found, fuel injection pump should be disassembled and repaired before proceeding with the tests. Additional operational tests performed on a damaged fuel injection pump could only increase the damage. If no cause for failure is found in inspection, fuel injection pump should be put on test stand and troubleshooting performed.

NOTE

Make certain that unusual noises are not produced by the test equipment used.

malfunctions that might be encountered, their probable cause, and the recommended corrective action.

2-9. Troubleshooting. Table 2-2 lists the possible

Table 2-2. Troubleshooting

Malfunction	Probable cause	Corrective action
<p>1. No fuel output.</p>	<p>a. Defective fuel supply pump assembly.</p> <p>b. Operating shaft frozen in operating shaft bearing.</p> <p>c. Operating shaft spring plate broken or not engaged with fulcrum lever or operating shaft.</p> <p>d. Fuel control rod bent or broken, fulcrum lever jammed in fuel shutoff position.</p> <p>e. Sheared plunger guide or seized plunger.</p> <p>f. Broken delivery valve spring.</p> <p>g. Plunger seat button broken.</p>	<p>Remove fuel supply pump assembly (para 3-4). Install new supply pump assembly (para 3-48).</p> <p>Remove operating shaft bearing assembly (para 3-25). Replace operating shaft and bearing, and install associated parts (para 3-25). Install assembly on governor housing.</p> <p>Refer to <i>b</i> above. Replace parts as necessary and install properly (para 3-25).</p> <p>Remove compensator (para 3-9); check linkage for freeness. Remove timing cover or solenoid housing (para 3-5 or 3-6). Remove control rod attaching nut (para 3-15, 3-16 or 3-25). Remove control unit (para 3-8). Remove and replace control rod through governor opening. Install control unit (para 3-44). Install compensator (para 3-46). Install timing cover or solenoid housing (para 3-47).</p> <p>Remove timing cover (para 3-5 or 3-6). Remove control unit assembly (para 3-8). Remove hydraulic head assembly (para 3-13). Install hydraulic head assembly (para 3-40). Install control unit (para 3-44). Install timing window cover (para 3-47).</p> <p>Remove delivery valve spring and replace (para 3-52).</p> <p>Remove hydraulic head (para 3-13) and check plunger seat button. Replace head if button is broken (para 3-40).</p>
<p>2. Fuel output cannot be controlled.</p>	<p>a. Incorrect idle and full speed adjustment.</p> <p>b. Operating shaft spring plate not engaged with fulcrum lever or operating shaft.</p> <p>c. Fuel control rod bent or broken.</p> <p>d. Broken fuel delivery valve spring or damaged valve.</p> <p>e. Fuel control unit pin not engaged with plunger sleeve.</p> <p>f. Friction drive spider worn.</p> <p>g. Broken camshaft extension.</p>	<p>Remove dust cover (para 3-25), check setscrews. Adjust idle and full speed adjustment screws (para 3-53). Install dust cover.</p> <p>Refer to 1 <i>c</i>.</p> <p>Refer to 1 <i>d</i>. Replace hydraulic head assembly. Refer to 1 <i>e</i>. Remove control unit (para 3-8) and assemble correctly (para 3-43). Remove and inspect spider (par 3-26). Disassemble pump and remove camshaft (para 3-16). Replace broken camshaft (para 3-37).</p>
<p>3. Unable to obtain sufficient fuel flow.</p>	<p>a. Fuel supply pump assembly defective.</p> <p>b. Broken outer plunger spring.</p> <p>c. Overflow valve stuck open.</p>	<p>Remove fuel supply pump assembly (para 3-41). Install new fuel supply pump assembly (para 3-48).</p> <p>Refer to 1 <i>c</i> above. Remove and replace outer plunger spring (para 3-13 and para 3-40). (Refer to 1 <i>e</i> for hydraulic head assembly.)</p> <p>Remove overflow valve (para 3-7). Install new overflow valve (para 3-45).</p>

Table 2-2. Troubleshooting-Continued

Malfunction	Probable cause	Corrective action
<p>4. Fuel leakage into oil lubrication system.</p>	<p>a. Hydraulic head lower ring gasket damaged.</p> <p>b. Worn hydraulic head plunger.</p> <p>c. Worn fuel supply pump housing oil seal.</p> <p>d. Worn or damaged control unit or packing.</p> <p>e. Leaking compensator.</p>	<p>Refer to 1 e for hydraulic head assembly removal and installation. Install new packing ring gasket. Replace hydraulic head. Refer to 1 e. Replace fuel supply pump assembly (para 3-44 and 3-48). Remove control unit (para 3-8). Replace packing and control unit if worn or damaged. Replace control unit (para 3-44). Replace compensator. Remove (para 3-9). Install compensator (para 3-46).</p>
<p>5. Fuel leakage around hydraulic head assembly.</p>	<p>Head upper ring gasket damaged.</p>	<p>Replace ring gasket. Refer to 1 e above for removal and installation of hydraulic head assembly.</p>
<p>6. Uneven fuel distribution.</p>	<p>a. Hydraulic head inner spring broken.</p> <p>b. Worn hydraulic head fuel plunger.</p> <p>c. Fuel plunger in hydraulic head sticking.</p> <p>d. Malfunction of test equipment.</p> <p>e. Governor unstable at part load fuel flow.</p> <p>f. Tappet roller bushing worn.</p>	<p>Replace hydraulic head assembly. Refer to 1 e. Replace hydraulic head assembly. Refer to 1 e. Replace hydraulic head assembly. Refer to 1 e. Inspect equipment and remedy malfunction. Remove governor housing (para 3-10), and check camshaft extension runout (para 3-42d). Repair or replace camshaft (para 3-43) and install governor housing. Remove tappet (para 3-14) and inspect tappet. Replace worn tappet and camshaft (para 3-16). Install camshaft (para 3-37). Install tappet (para 3-39).</p>
<p>7. Excessive vibration.</p>	<p>a. Excessive camshaft runout.</p> <p>b. Governor weight and spider assembly worn or damaged.</p> <p>c. Camshaft ball bearing worn or damaged.</p> <p>d. Camshaft bushing type bearing worn or damaged.</p> <p>e. Advance unit housing bushing type bearing worn or damaged.</p> <p>f. Advance unit weight and spider worn or damaged.</p>	<p>Remove governor (para 3-10). Check camshaft runout (para 3-42). If runout is excessive, replace camshaft. Remove governor weight and spider assembly (para 3-11). Install a new weight and spider assembly (para 3-42). Remove camshaft (para 3-16) and ball bearing (para 3-31). Install new camshaft bearing (para 3-31) and camshaft (para 3-31). Replace metering and distributing fuel injection pump. Replace metering and distributing fuel injection pump. Remove weight and spider assembly (para 3-11). Install new weight and spider assembly (para 3-42).</p>

CHAPTER 3

REPAIR OF FUEL INJECTION PUMP

Section I. GENERAL

3-1. Removal and Installation. Refer to TM 9-2815 210-34 and TM 9-2815-204-34 for instructions covering the removal and installation of the metering and distributing fuel injection pump assembly. Refer to TM 9-2815-210-34P for procurement of cap plug set, FSN. 5340-450-5718, for covering fuel system openings.

3-2. Cleaning Before Disassembly.

CAUTION

Absolute cleanliness of fuel pump parts must be maintained during all disassembly, inspection, repair, and assembly procedures. Dust, dirt, grime, or any abrasive matter

must not come in contact with precision lapped surfaces of internal parts.

a. Clean the fuel injection pump externally before disassembly procedures start. The external cleaning procedures listed in *b* and *c* below are recommended for all fuel injection pumps.

b. Cover or plug all threaded ports and openings to prevent entrance of foreign matter during external cleaning operations.

c. Use volatile mineral spirits paint thinner or dry cleaning solvent and scrub the pump with a soft bristle brush to remove all external accumulation of grease, dirt, or other foreign matter.

Section II. DISASSEMBLY OF FUEL INJECTION PUMP INTO SUBASSEMBLIES

3-3. General. *a.* Disassemble the metering and distributing fuel injection pump in figure number sequence.

b. All packings, gaskets, and sealing rings must be discarded during disassembly to insure replacement.

c. Do not remove any hose or tube fittings unless there is evidence of leakage or darn age.

3-4. Removal of Fuel Supply Pump Assembly. Refer to figure 3-1. Remove two machine screws (B), lock-washers (C), and remove the fuel supply pump assembly (D). Remove and discard supply pump gasket (E).

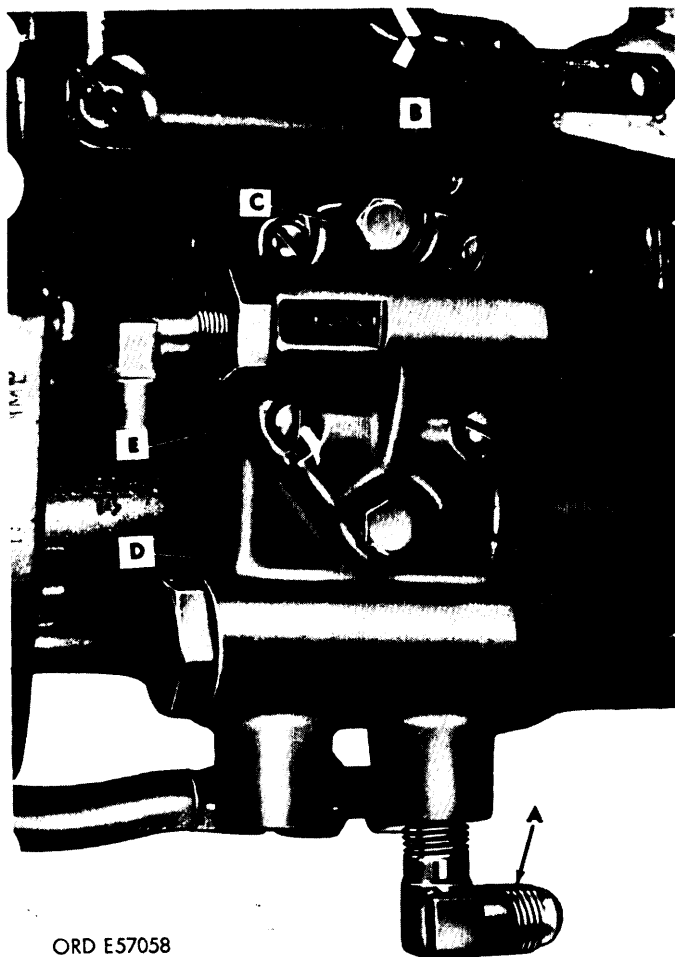

Figure 3-1. Removing fuel supply pump.

3-5. Removal of Timing Window Cover and Fuel Shutoff Rod Assembly (All Except Code A Pumps). Refer to figure 3-2. Remove two fillister-head screws (A) and lockwashers (B). Remove timing window cover and fuel shutoff rod assembly (C). Remove and discard timing window cover gasket (D).

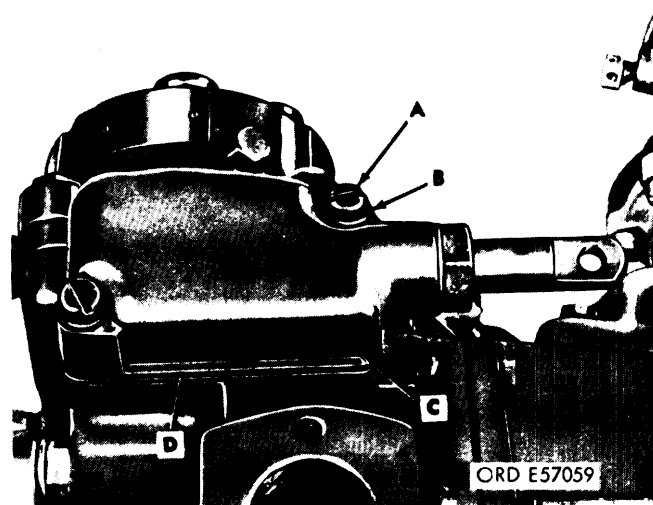

Figure 3-2. Removing timing windows cover and fuel shutoff rod (all pumps except code A).

3-6. Removal of Fuel Shutoff Solenoid Cover Assembly (Code A Injection Pump). Refer to figure 3-3. Remove lockwire (A), two socket head screw (B) and lockwashers (C). Remove fuel shutoff solenoid cover assembly (D). Remove and discard solenoid cover gasket (E).

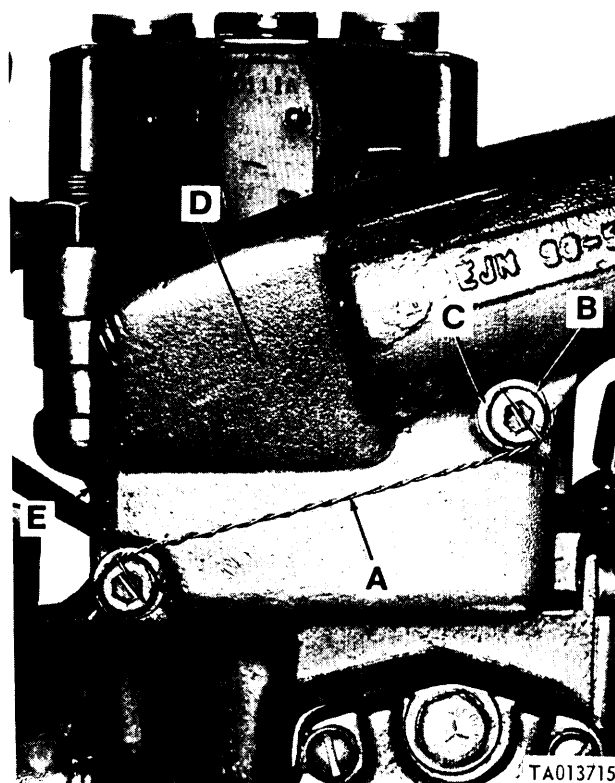
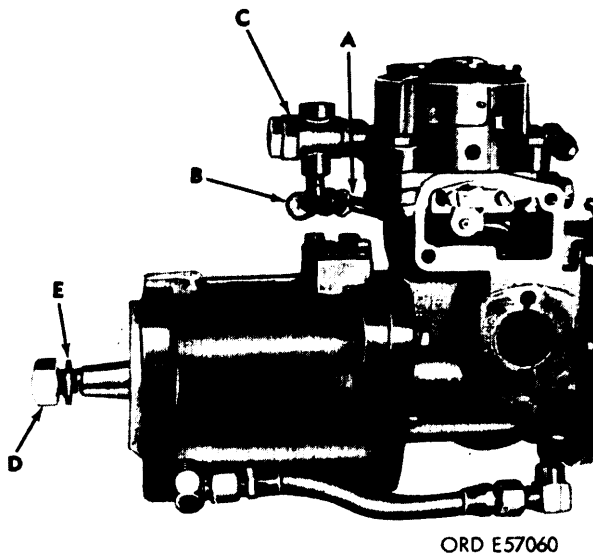

Figure 3-3. Removing solenoid cover assembly (code A pumps).

3-7. Removal of Overflow Valve Assembly. *a.* Coda *A, B, C, D, E, F* and late *G* pumps. Refer to figure 3-4. Disconnect tubing (*A*) from tee fitting (*B*). Remove overflow valve (*C*). Remove hex nut (*D*) and lockwasher (*E*).



*Figure 3-4. Removing overflow valve assembly
(all pumps except early code G).*

b. Early code *G* pumps. Refer to figure 3-5. Remove overflow valve (*D*) and woodruff key (*A*), hex nut (*B*) and lockwasher (*C*).

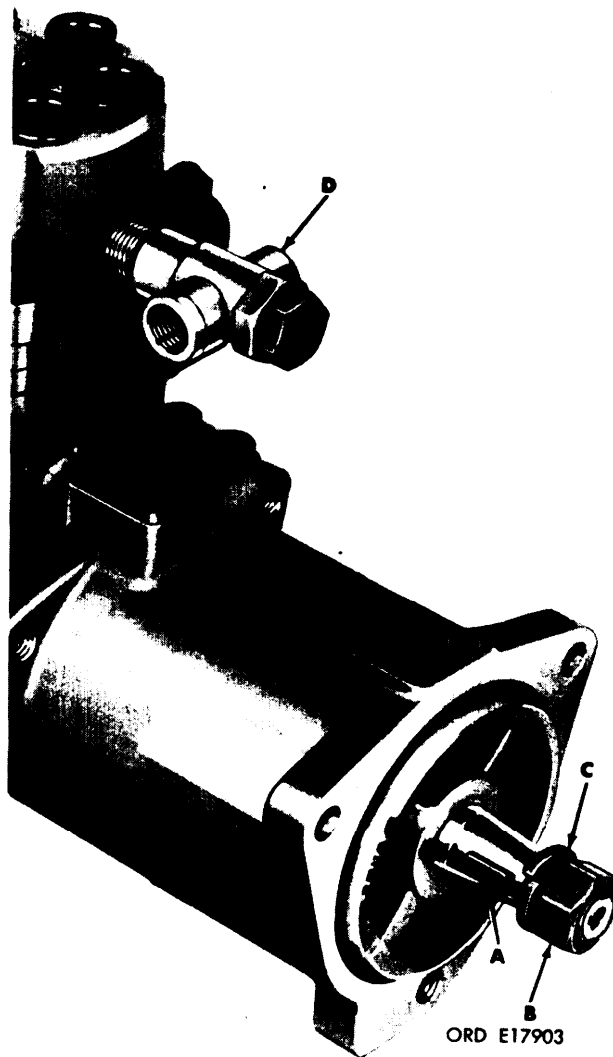

*Figure 3-5. Removing overflow valve assembly
(early code G pumps).*

3-8. Removal of Fuel Control Unit Assembly. Refer to figure 3-6. Remove retaining pin (A). Cut locking wire (B) and remove two screws and lockwashers (C). Remove control unit retainer (D) and fuel control unit assembly (E).

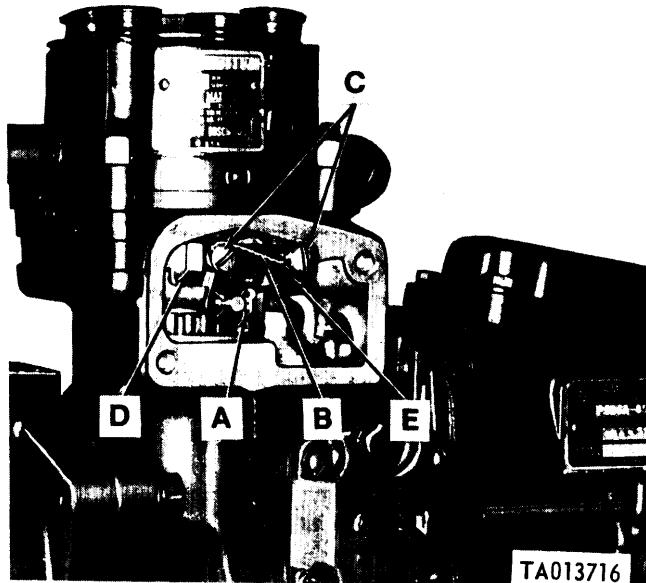

Figure 3-6. Removing fuel control unit assembly.

3-9. Removal of Fuel Density Compensator Assembly and Governor Cover and Stop Plate and Bridge. a. General The fuel density compensator assembly is mounted above the governor housing. A hose or tube (A, fig. 3-7) connects the density compensator to the hydraulic head and carries fuel under pressure to the head. Excess or overflow fuel is carried from the density compensator to the overflow valve assembly by a tube (B).

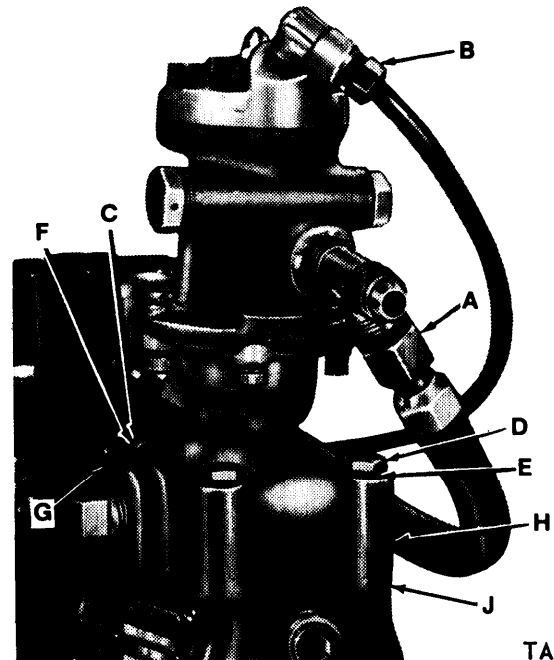

Figure 3-7. Removing fuel density compensator (early code F pumps).

b. Removal of Compensators.

(1) *Early code F injection pump.* Refer to figure 3-7. Remove hose assembly (A) and tube (B) from tees and elbows. Remove and discard locking wire and seal (C). Remove four cap screws (D), lockwashers (E), tamper proof cover (F) and spacers (G) securing compensator to governor housing. Tap fuel density compensator (H) with a soft hammer to break gasket seal and remove fuel density com-

compensator assembly and gasket (J) from governor housing. Discard gasket, compensator assembly, tube and hose as this compensator assembly 2910-017-9776 will be replaced with compensator assembly 2910-907-0665.

(2) *Code A, B, C, D, E and late F injection pumps.* Refer to figure 3-8. Remove tube assembly (A) from tee and from elbow in hydraulic head. Disconnect tubing (B) from elbow. Remove and discard locking wire and seal (C). Remove four capscrews (D), lockwashers (E), tamper proof cover (F) and clip securing compensator to governor housing. Tap fuel density compensator (G) with a soft hammer to break gasket seal and remove fuel density compensator assembly (G) and gasket (H) from governor housing. Discard gasket and retain compensator assembly for possible repair.

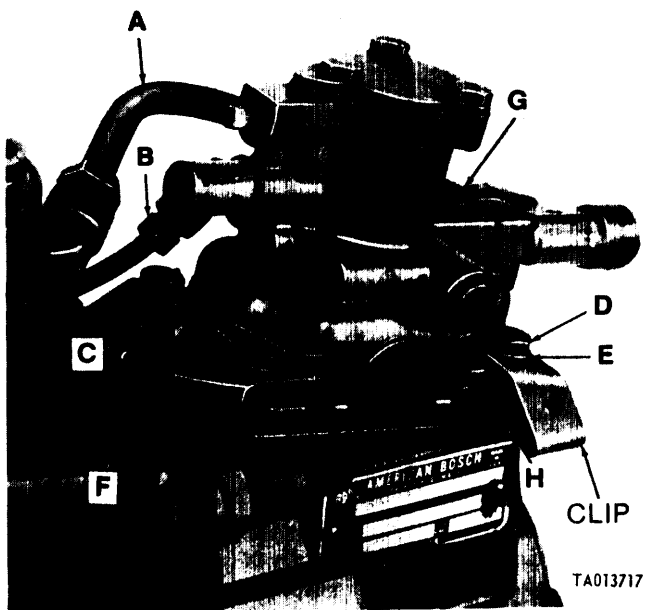

Figure 3-8. Removing fuel density compensator (code A, B, C, D, E and late code F pumps).

(3) *Code A injection pump compensators.* Refer to figure 3-9. Compensator 2910-125-3793 uses an additional fuel limiting stop. This stop (A) is attached to the torque link (b), and is furnished with new compensator.

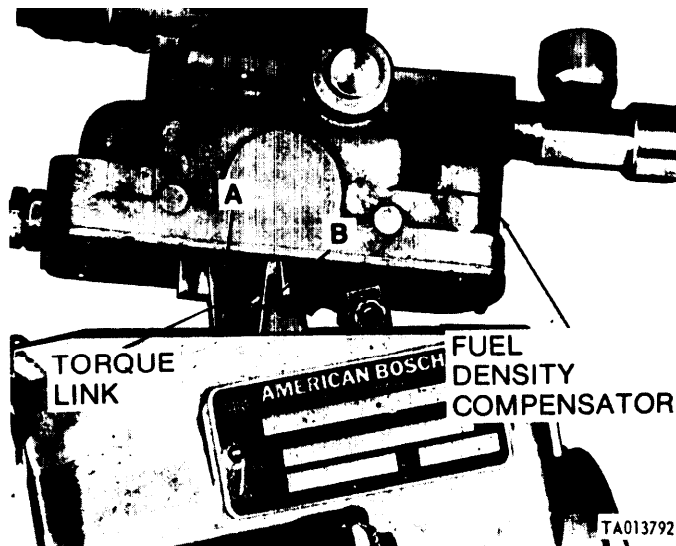

Figure 3-9. Removing fuel density compensator (code A pumps).

c. *Removal of Governor Cover and Stop Plate and Bridge Assembly.*

NOTE

Paragraphs (1) through (3) below refer to code G injection pumps only.

(1) Refer to figure 3-10. Remove four machine screws (A) and lockwashers (B). Remove governor cover (C). Remove and discard cover gasket (D).

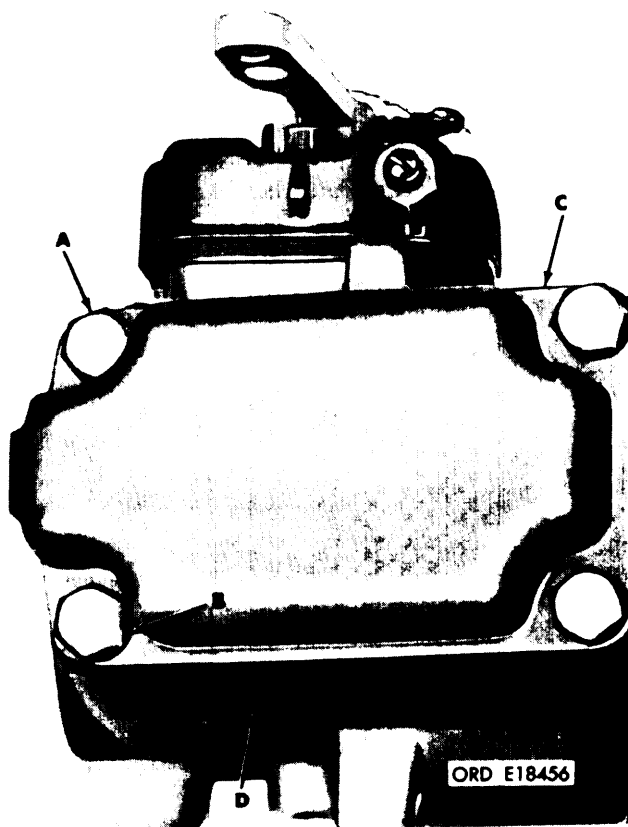

Figure 3-10. Removing governor cover (code G pumps).

(2) Refer to figure 3-11. Remove two capscrews (A), lockwashers (B), and flat washers (C). Remove stop plate and bridge assembly (D).

(3) Refer to figure 3-12. Remove nut (A), lockwasher (B), stop plate bridge (C), lockwasher (D) and nut (E) from stop plate.

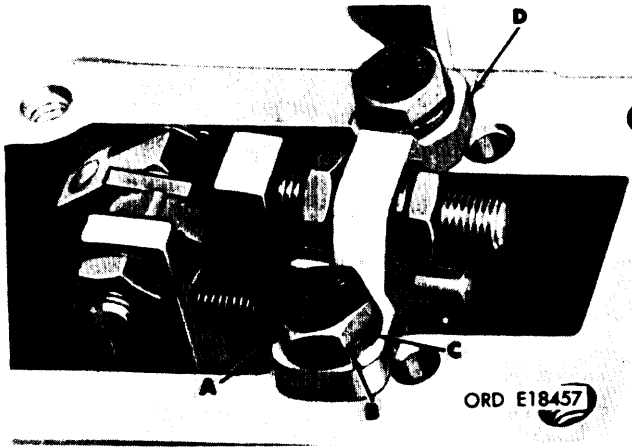
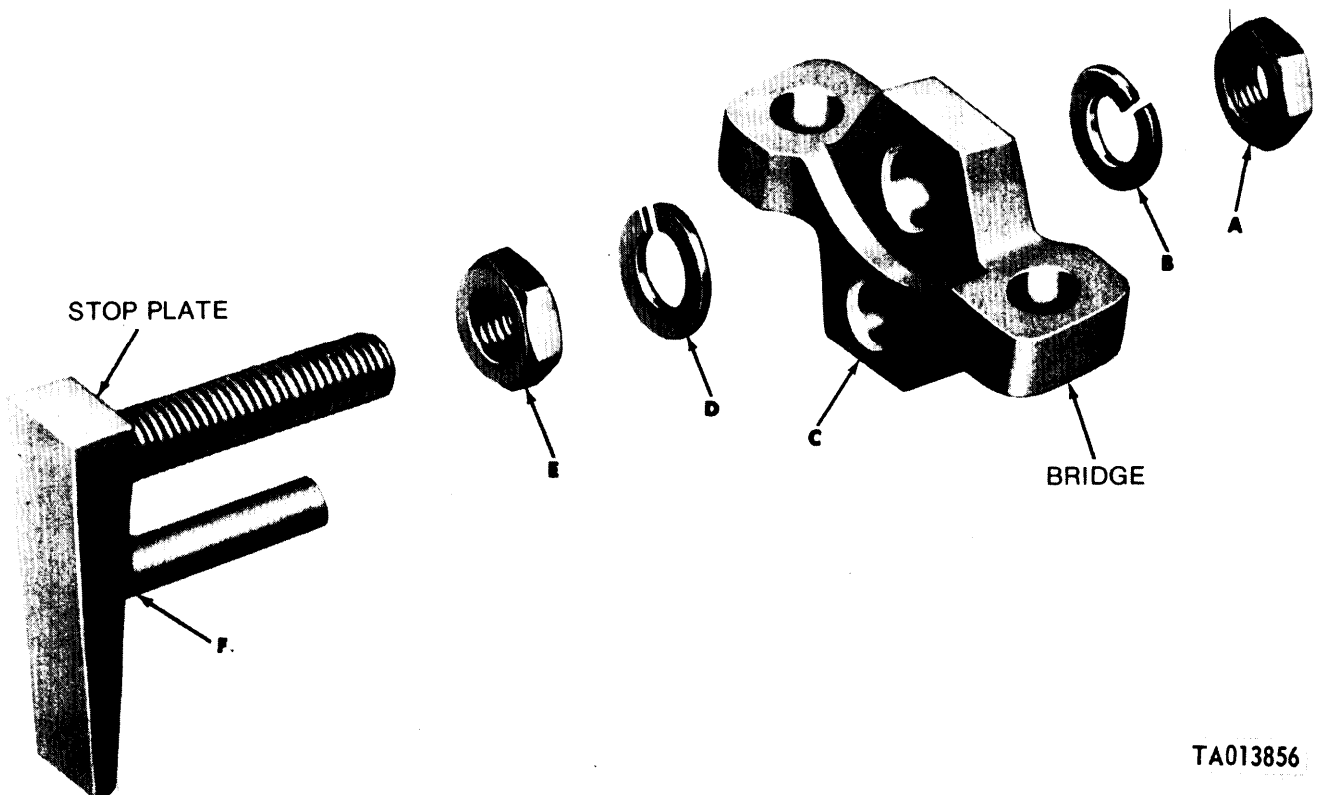

Figure 3-11. Removing stop plate and bridge assembly (code G pumps).



TA013856

Figure 3-12. Disassembling stop plate and bridge assembly (code G pumps).

3-10. Removal of Governor. Refer to figure 3-13. Cut locking wire (A) and remove three capscrews (B), lockwashers (C), and two machine screws (D) and

lockwashers (E). Remove governor housing and associated parts (F). Remove and discard governor housing gasket (G).

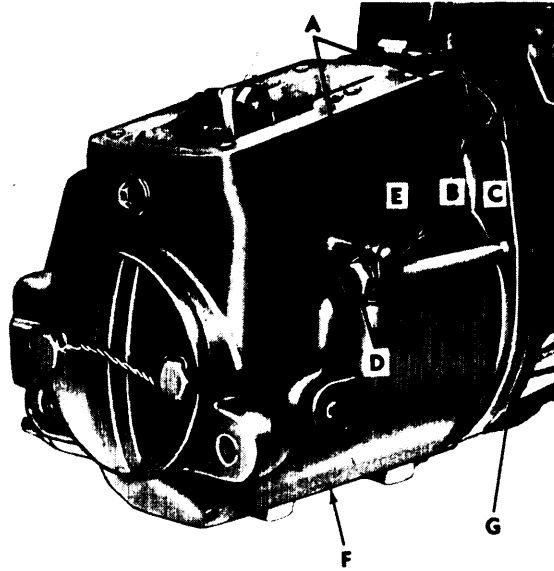

ORD E57062

Figure 3-13. Removing governor assembly.

3-11. Removal of Governor Weight and Spider Assembly. Refer to figure 3-14. Position remover and replacer against the camshaft shoulder. If the remover and replacer does not clear the governor weight fingers, rotate the friction drive spider while keeping the camshaft stationary. Install the puller,

and turn puller screw slowly until the weight and spider assembly is removed from the camshaft.

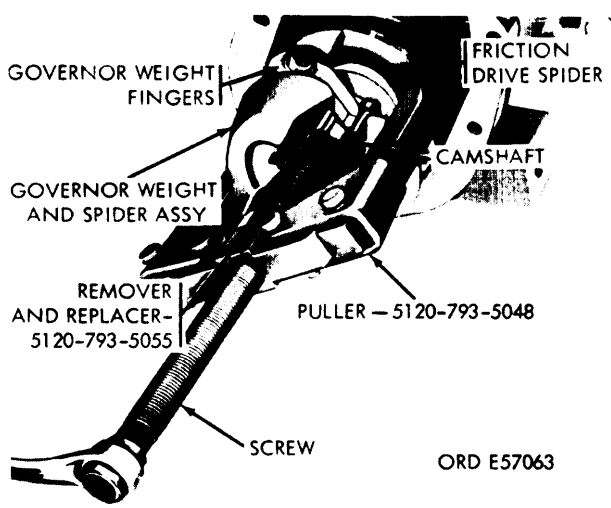
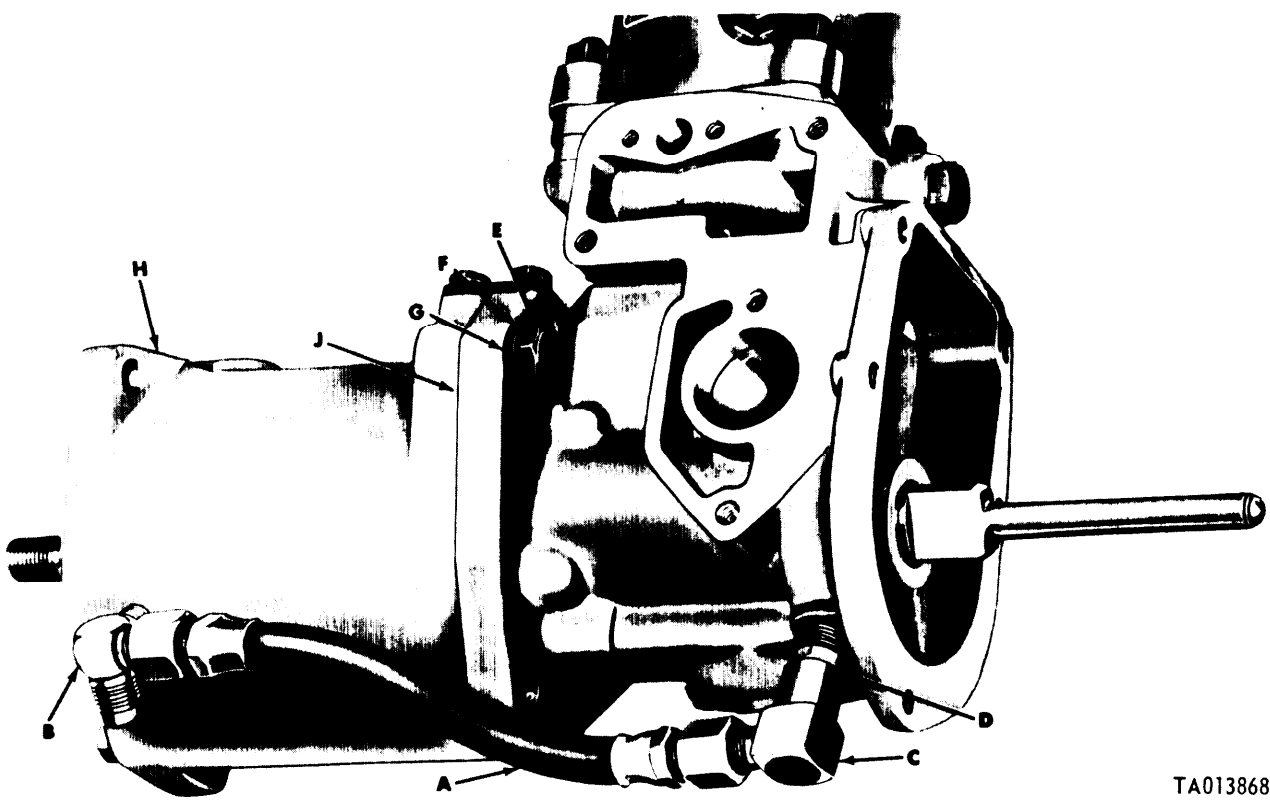

Figure 3-14. Removing governor weight and spider assembly using puller 5120-793-5048 and remover and replacer 5120-793-5055.

3-12. Removal of Timing Device Assembly. a. Refer to figure 3-15. Disconnect and remove oil hose assembly (A), pipe-to-tube tee (B), pipe-to-tube elbow (C) and hex nipple (D). Remove two capscrews (E), lockwashers (F) and flat washers (G). Remove timing device assembly (H). Remove and discard preformed packing (J).



TA013868

Figure 3-15. Removing timing device assembly.

b. Refer to figure 3-16. Rotate camshaft until slotted tooth of plunger drive gear aligns with arrow on injection pump housing. Lock camshaft in this position using camshaft fixture.

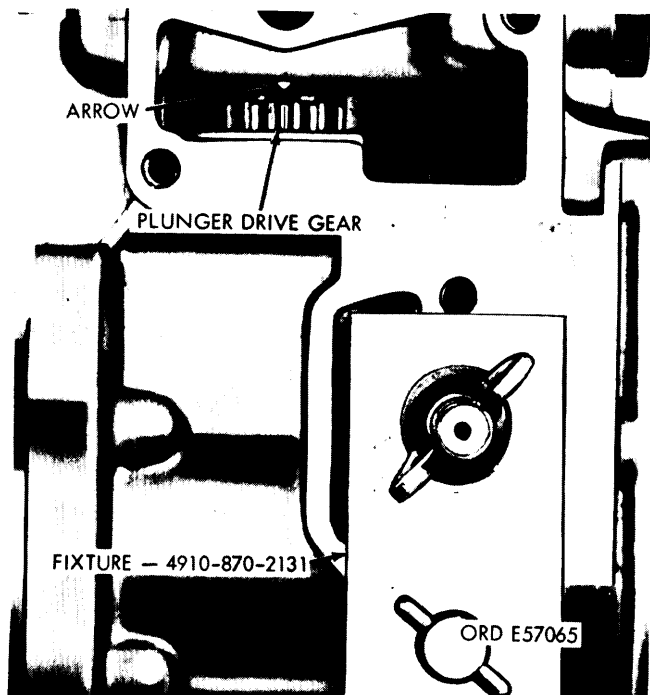

Figure 3-16. Locking camshaft using fixture-4910-870-2131.

c. Refer to figure 3-17. Loosen camshaft nut setscrew (A) and camshaft nut (B) two or three turns.

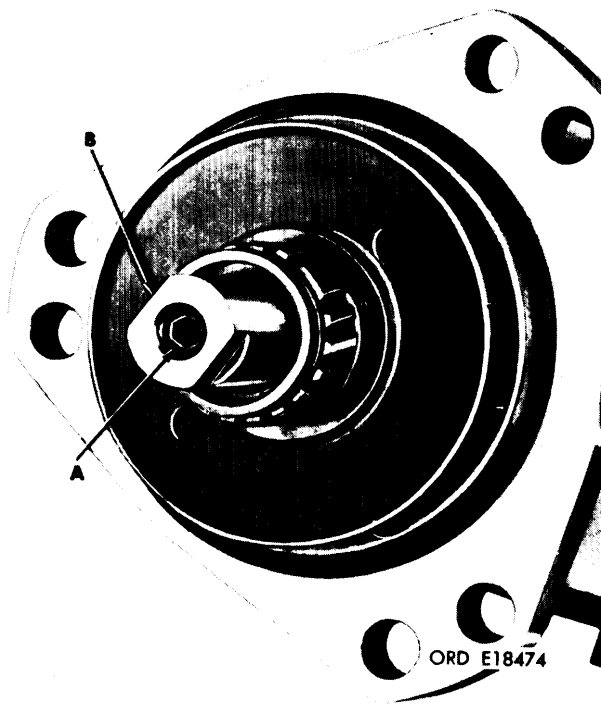

Figure 3-17. Loosening camshaft nut.

d. Refer to figure 3-18. Position puller (A) and loosen timing device hub (B).

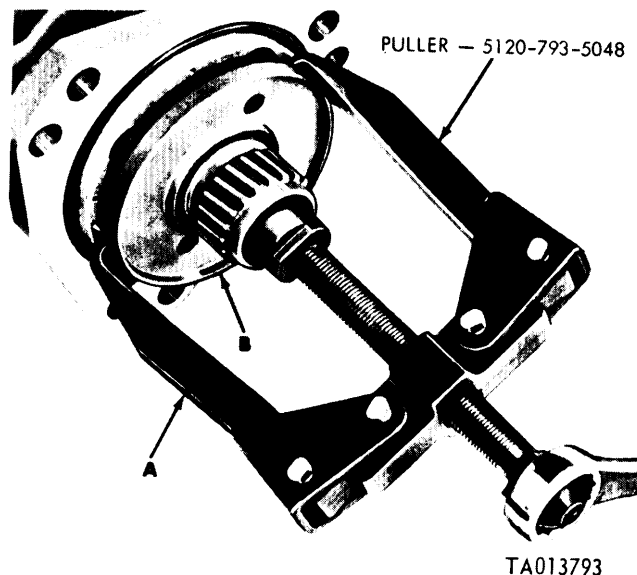

Figure 3-18. Removing timing device hub using puller - 5120-793-5048.

e. Refer to figure 3-17. Remove camshaft nut setscrew (A), camshaft nut (B) and timing device hub.

f. Refer to figure 3-19. Remove Woodruff key (A).

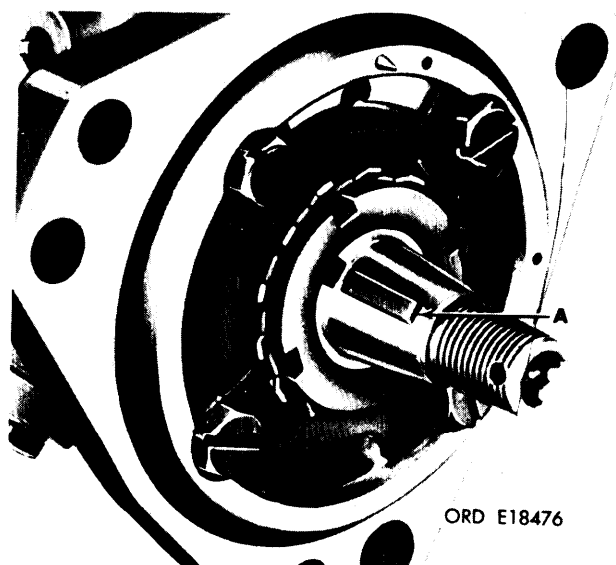

Figure 3-19. Removing or installing pump Woodruff key.

3-13. Removal of Hydraulic Head Assembly.

NOTE

Sub-Paragraph a below applies only to code F and G injection pumps.

a. Refer to figure 3-20. Remove oil filter screw (A). Remove and discard filter screw copper gasket (B) and remove oil filter (C). Or remove screw (D),

remove and discard washer (E). Remove pin (G), remove and discard packing (F).

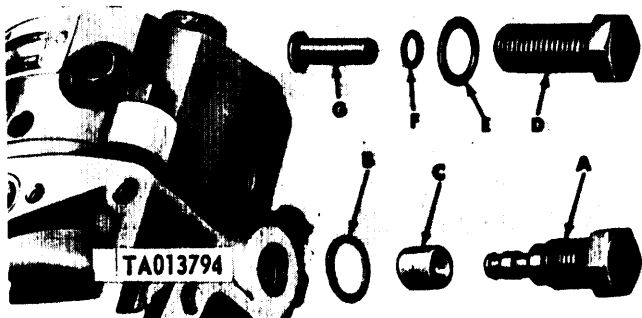

Figure 3-20. Removing oil filter or oil duct sealing screw assembly (code F and G pumps).

b. Refer to figure 3-21. Install pump holding fixture on pump body and position fixture in a vise. Remove four hydraulic head plain nuts (A), four stud sleeves (B) and hydraulic head assembly (C) from housing.

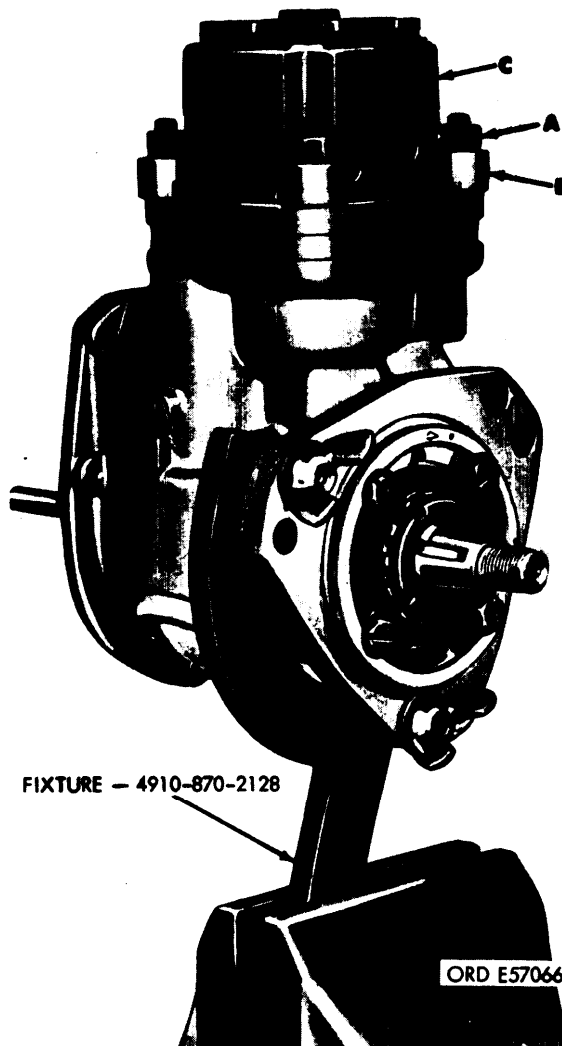

Figure 3-21. Removing hydraulic head assembly using pump holding fixture-4910-870-2128.

3-14. Removal of Tappet Assembly. *a.* Refer to figure 3-22. Remove and discard filter screw packing. Remove fixture.

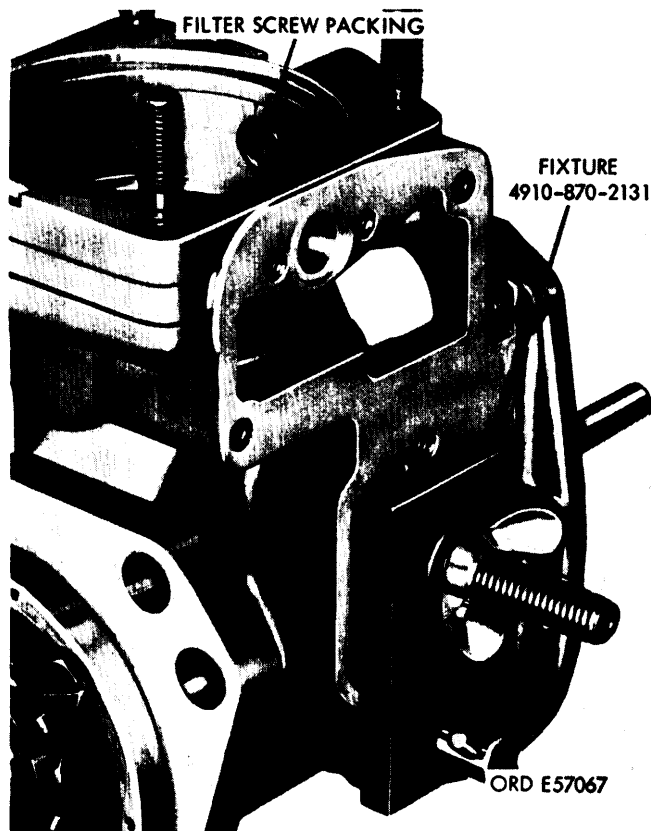

Figure 3-22. Removing fixture -4910-870-2131 prior to removal of tappet assembly.

b. Refer to figure 3-23. Position spring compressor so that holes in spring retaining ring (C) are accessible. Install two stud sleeves (A) and hydraulic head nuts (B). Turn thumb screw clockwise finger tight to compress plunger outer spring. Remove spring retaining ring (C) using suitable pliers. Release tension on plunger outer spring by turning thumb screw counterclockwise and remove spring compressor from housing.

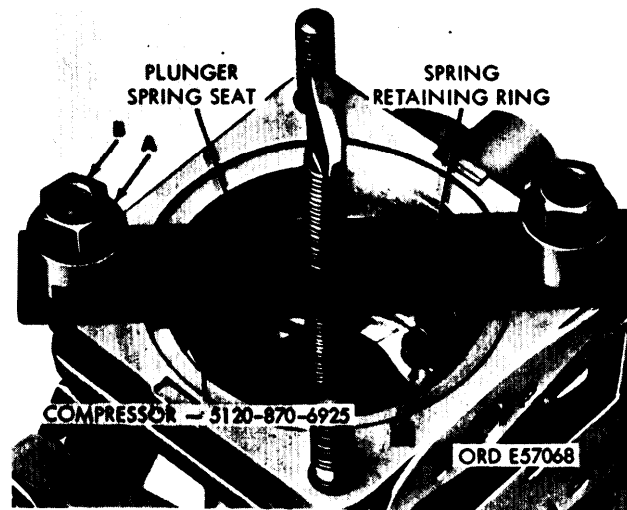

Figure 3-23. Removing spring retaining ring using spring compressor—5120-870-6925.

c. Refer to figure 3-24. Remove plunger spring seat (A), plunger outer spring (B), and tappet assembly (C).

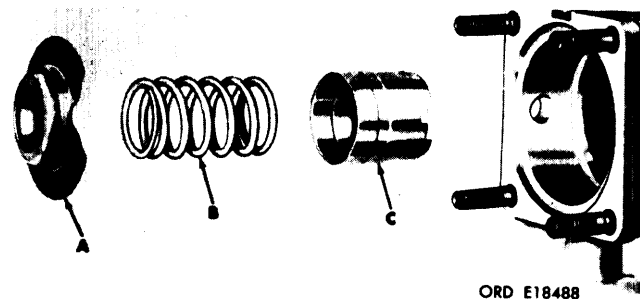

Figure 3-24. Removing tappet assembly.

3-15. Removal of Quill Shaft Assembly. *a.* Refer to figure 3-25. Cut locking wire (A) if present. Remove two capscrews (B), copper gaskets (C), and quill shaft pad cover (D). Discard copper gaskets. Remove and discard cover gasket (E).

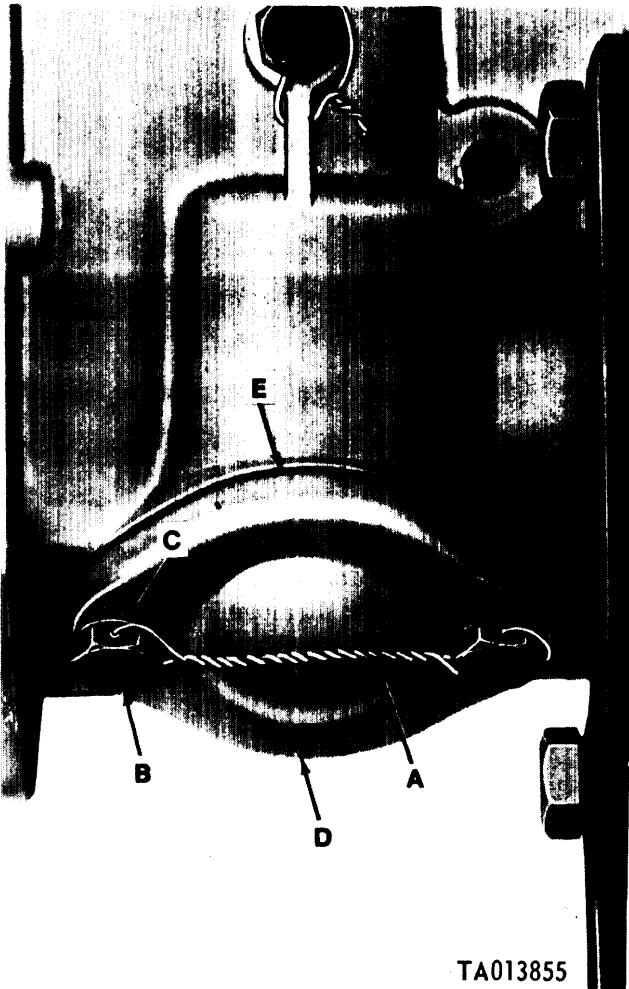

Figure 3-25. Removing quill shaft pad cover.

b. Refer to figure 3-26. Cut locking wire (A) and remove machine screw (B) and copper gasket (C). Discard copper gasket. Remove quill shaft assembly (D).

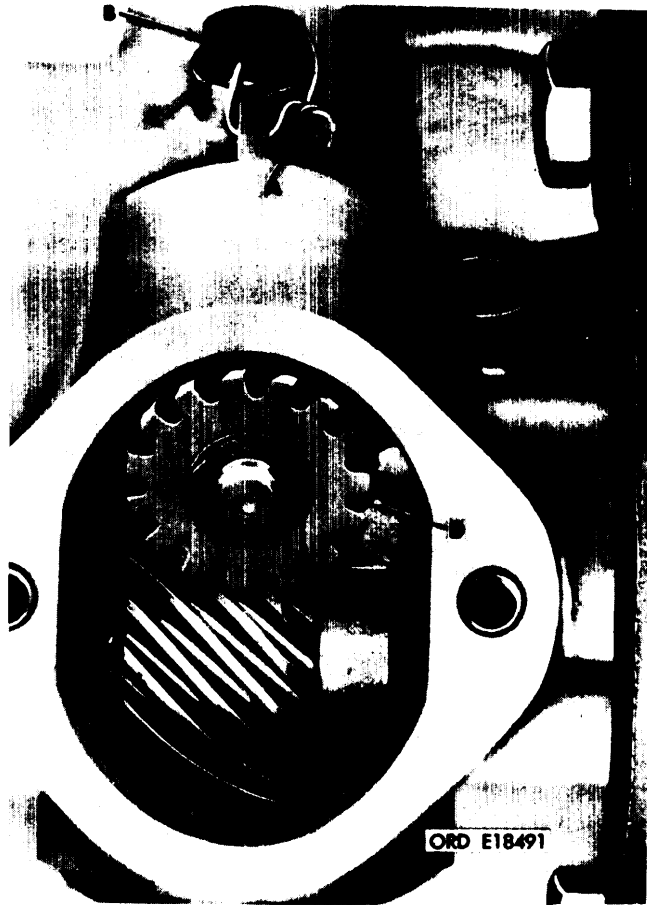

Figure 3-26. Removing quill shaft assembly.

3-16. Removal of Camshaft. a. Refer to figure 3-27. Straighten tabs on lockwashers (A) and remove four machine screws and lockwashers (B). Remove bearing retaining plate (C). Remove pump housing from holding fixture.

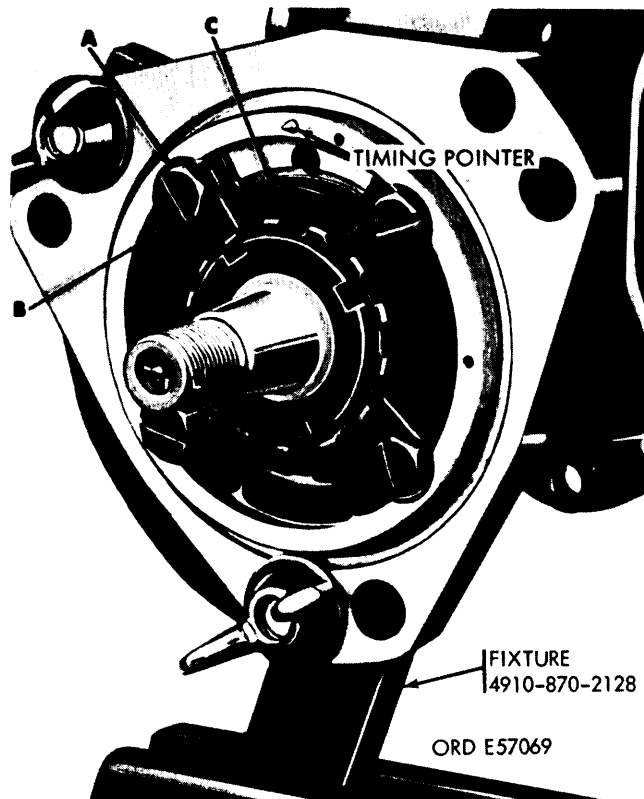

Figure 3-27. Removing bearing retaining plate.

b. Refer to figure 3-28. Place the pump housing (A) on bed of arbor press. Position remover and replacer on camshaft (B) and press the camshaft and associated parts from the pump housing.

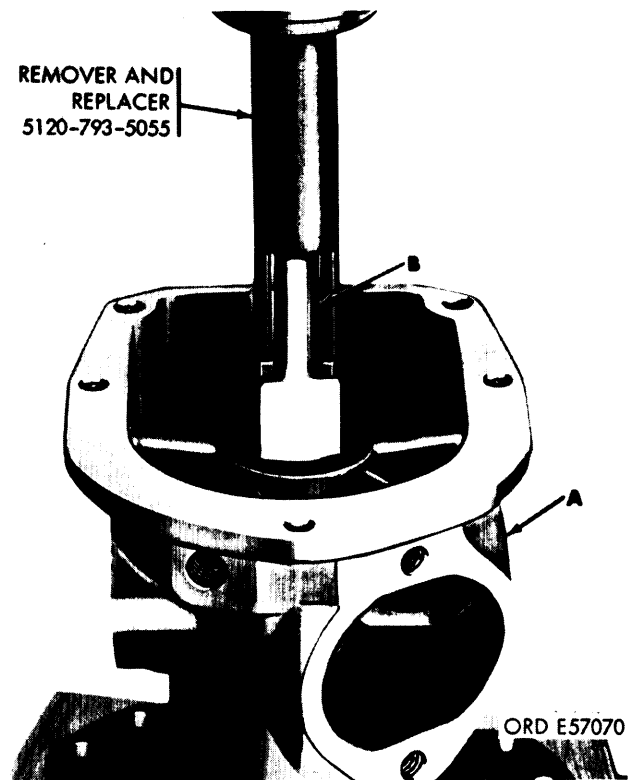

Figure 3-28. Pressing camshaft and associated parts from pump housing using remover and replacer 5120-793-5055.

Caution

Support the pump housing so that the timing pointer (fig. 3-27) will not be damaged.

Section III. REPAIR OF FUEL INJECTION PUMP COMPONENTS

3-17. General. a. *Parts Identification.* Because of the numerous pump models repaired in this section of the manual a ready reference to parts is provided in table 3-1. Parts in appendix B are coded the same as the pumps.

(1) *Column 1, nomenclature.* Defines pump and part name.

(2) *Columns 2 through 5.* These columns list the pumps as coded with the part number of the part applicable to the particular pump. The numbers

indicated are the Army number, Federal stock number, and the manufacturer's part number (American-Bosch, FSCM 01843).

(3) *Column 6, remarks.* Defines differences in parts shown in columns 2 through 6 for the particular part, indicates optional parts, and also shows parts available in kits.

b. *Illustrations.* Figures 3-29 through 3-37 are exploded views of the pumps and show the different parts applications.

Table 3-1. Injection Pump Parts Identification

Nomenclature	Code A	Code B	Code C & D	Code E	Code F	Code G	Remarks
Pump assembly w/compensator	11641907 2910-178-1185	10951115 2910-908-6320	10935264 2910-759-5410	10935264 2910-759-5410	10935498 2910-017-9778 See remarks		For service use Pump—10951115 and modify by changing fuel fittings.
Pump assembly	11641906 PSB6A90EH5371G	10951116 2910-930-8645 PSB6A90EH5828A	10935261 PSB6A90EH5337A	10935261 PSB6A90EH5337A	10935270 PSB6A90EH5327B	10935295 2910-968-6317 PSB6A85EH5250D	
Compensator assembly	11641870 2910-125-3793 CU9029A See remarks (1)	10951200 2910-907-0665	10951200 2910-907-0665	10951200 2910-907-0665	10951200 2910-907-0665 See remarks (2)		(1) Includes torque fuel control stop—11641873 (ST901)—KIT 5704373. (2) Optional with compensator—10935439 (change fuel fittings).
Compensator mounting gasket	7383459 (all) 2910-310-6556 (all) GA908 (all)					See remarks	Code G pump cover gasket same as compensator gasket.
Hydraulic head assembly	11662498 2910-762-4623 HD90111A	11602722 2910-828-7167 HD90101A	11602721 2910-828-7176 HD90100A	11602721 2910-828-7176 HD90100A	11602722 2910-828-7167 HD90101A	10914599 2910-871-5435 HD9065A	See fig. 3-99 and 3-124 for additional heads and information. Code A and B heads same except for inlet fuel fitting position.
Fuel supply pump	10947153 4320-908-6322 SGB25C23	10947558 4320-908-6321 SGB25C25 See remarks (1)	10947558 4320-908-6321 SGB25C25 See remarks (1)	10947558 4320-908-6321 SGB25C25 See remarks (1)	10947153 4320-908-6322 SGB25C23 See remarks (2)	7748851 2910-871-5428 SGB25C15	(1) Supersedes Pump—SGB25C21 (thin bores). (2) Optional w/Pump—SGB25C19 w/overflow valve—VA9053A. KIT—5704368. See fig. 3-41.
Overflow valve assembly	10947157 (all) 2910-908-6324 (all) VA9032A				See remarks	7748843 2910-871-5440 VA9051A	Code F pump overflow valve optional w/Valve—VA9053A (used w/Fuel Supply Pump—SGB25C19). See figs. 3-38, 3-39 and 3-40 for identification.
Operating lever assembly	11662495 2910-492-8143 LE90116A See remarks	10935303 (all) 2910-968-6320 (all) LE9010A (all)					Code A pump operating lever and stop is one piece.
Operating shaft bearing	11662496 BG9042 See remarks (1)	7748821 (all) 2910-871-5434 (all) BG9034 (all) See remarks (2)					(1) Available in KIT—5704371. See fig. 3-75. (2) Available in KIT—5704377.

Table 3-1. Injection Pump Parts Identification—Continued

Nomenclature	Code A	Code B	Code C & D	Code E	Code F	Code G	Remarks
Spring plate assembly	PL9055A See remarks (1)		7383473 (all) 2910-786-0193 (all) PL902A (all) See remarks (2)				(1) Available in KIT—5704371. See fig. 3-75. (2) Available in KIT—5704377.
Fuel shutoff rod assembly	11662499 2910-421-3941 HG90100A See remarks		10914598 (all) 2910-871-5439 (all) RD9041A (all)				Code A pumps have a solenoid assembly providing electrical fuel shutoff. See fig. 3-3 and 3-46.
Governor inner spring	10951113 2910-836-7316 SP7950-16 See remarks	10923499 2990-850-3260 SP7950-11 See remarks	10923499 2990-850-3260 SP7950-11 See remarks	LDT-465-1C use SPRING 11668460 5360-081-5977 SP7950-22	10923499 2990-850-3260 SP7950-11 See remarks	10923499 2990-850-3260 SP7950-11 See remarks	Springs marked on one end surface for identification (e.g. SP7950-16 marked 50-16) See spring identification fig. 3-143.
Governor outer spring	11588685 5340-930-5140 SP7951-12	11588685 5340-930-5140 SP7951-12	11588685 5340-930-5140 SP7951-12	LDT-465-1C use SPRING 7383463 2990-830-3882 SP7951-13	11588685 5340-930-5140 SP7951-12	10923488 2910-846-4653 SP7951-11	See fig. 3-142.
Governor weight and spider assembly			11662497 (all) 2910-762-4588 (all) WT9031A (all) See remarks				On code C, D and E pumps governor weight and spider assembly is optional with WT9024.
Advance unit spring	SP857-3 See remarks (1)	SP9041 See remarks (2)	SP9043 See remarks (3)	SP9043 See remarks (3)	SP9041 See remarks (2)	SP9041 See remarks (2)	(1) Available in KIT—5704370 (2) Available in KIT—5704378 (3) Available in KIT—5704379
Control unit assembly	11662500 2910-936-7780 CU9032A		10947152 (all) 2910-907-0674 (all) CU9017A			10914588 2910-871-5437 CU9013A	See fig. 3-48, 3-49 and 3-50.
Control unit plunger sleeve pin			10914589 (all) 5315-217-3457 (all) PN906 (all)				Always replace pin if control unit is replaced. See para. 3-23 and 3-44.
Tappet assembly			10947156 (all) 2910-907-0673 (all) TP904A (all)			10914597 2910-036-4152 TP903A	See fig. 3-118.
Quill shaft assembly			10914590 (all) 2910-871-5436 (all) SH9017A				See fig. 3-104.

Table 3-1. Injection Pump Parts Identification—Continued

3-14

TM 9-2910-226-34

Nomenclature	Code A	Code B	Code C & D	Code E	Code F	Code G	Remarks
Governor sleeve assembly	SV9028A See remarks		7748546 (all) SV901A (all)				SV9028A is SV901A machined for clearance.
Fulcrum lever assembly	11662502 2910-762-4590 LE90118A	10947544 2910-999-5407 LE90103A	10947545 2910-41-8312 LE90112A See remarks	10947545 2910-41-8312 LE90112A See remarks	10947544 2910-999-5407 LE90103A	10947543 2910-235-4791 LE9096A	Lever assembly—LE90112A same as LE90103A with droop screw removed (see fig. 3-67). Use lever assembly—LE90103 on code E pumps.
Oil baffle	BA906 See remarks		2910-797-3592 (all) BA902 (all)			BA904	Code A baffles have added clearance for fulcrum lever and torque link arm. See fig. 3-86.
Governor housing	HG9098 See remarks		HG9079 (all)			HG9074A	Code A housings have added clearance for fulcrum lever and torque arm. See fig. 3-72.
Shutoff rod gasket	None used		105453 (all) 5330-190-4311 (all) GA1036				Code A pumps do not have shutoff rod.
Timing window cover/solenoid gasket			11662856 (all) 5330-419-9467 (all) GA9033 (all) See remarks				Gasket—11662856 superseded gasket—7748841 (GA9026). Do not use GA9026 on code A pumps.
Timing housing to pump housing oil hose assembly			7748847 (all) 2910-879-1676 (all) TU9027 (all)				
Pump housing to oil hose elbow			10935557 (all) 4730-903-6645 (all) F11304 (all)				Elbow replaces nipple used on early pumps.
Engine stop cable clip	None used	10896235	None used	None used	10896235	10896235	See fig. 3-30.
Throttle control return spring bracket	None used	10938294			None used		See fig. 3-30.
Hydraulic head inlet tube vs. hose	Tube	Tube	Tube	Tube	Hose	Hose	All overhauled pumps have tube replacing hose.
Operating lever position	Up	Down	Down	Down	Up	Up	See fig. 3-82.

Table 3-1. Injection Pump Parts Identification— Continued

Nomenclature	Code A	Code B	Code C & D	Code E	Code F	Code G	Remarks
Torque link assembly	Yes			No			See fig. 3-65 and 3-66.
Tamper-proof cover kit				2910-246-3997 (all)			

KEY to fig. 3-29

- A Overflow valve tee assembly**
- B Lead seal**
- C Tamper proof cover**
- DD ¼ inch lockwasher**
- E ¼ x 1¼ capscrew**
- F Fuel density compensator overflow tube.**
- G Fuel density compensator to hydraulic head tube.**
- H Compensator assembly**
- J Compensator assembly gasket**
- K Fuel injection pump assembly**
- L Fuel injection supply pump outlet elbow assembly.**
- M Fuel injection supply pump inlet elbow.**
- N Adapter**
- P Flame heater fuel supply elbow assembly.**
- Q Overflow valve elbow assembly**
- R Hydraulic head elbow assembly**

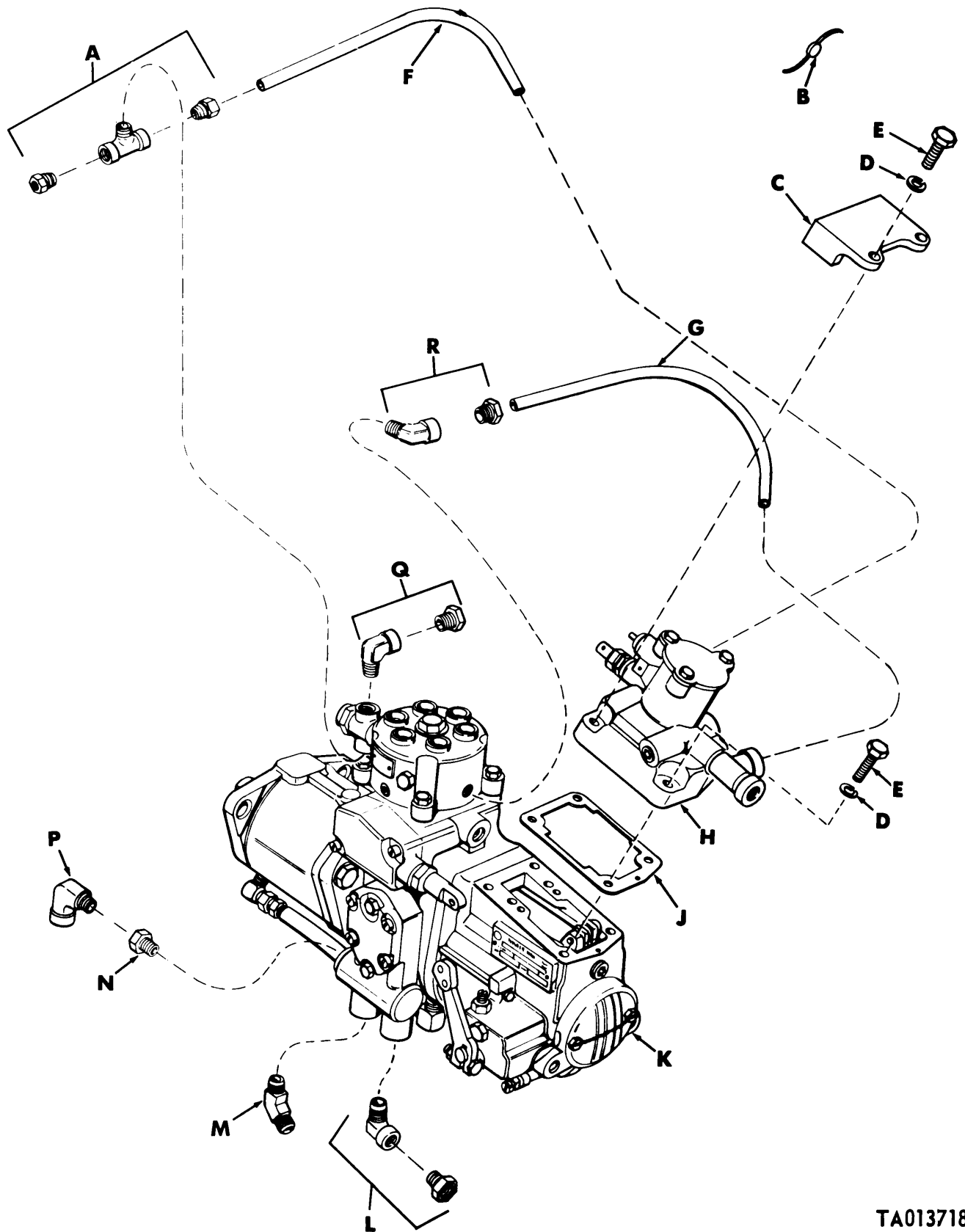

TA013718

Figure 3-29. Code A fuel injection pump assembly, partial exploded view.

KEY to fig. 3-30

- A Overflow valve tee assembly**
- B Lead seal**
- C Tamper proof cover**
- D $\frac{1}{4}$ x $1\frac{1}{4}$ capscrew**
- E Fuel density compensator overflow tube.**
- F Fuel density compensator to hydraulic head tube.**
- G $\frac{1}{4}$ inch lockwasher**
- H Clip**
- J Compensator assembly**
- K Compensator assembly gasket**
- L Fuel injection pump assembly**
- M Fuel supply pump outlet elbow assembly.**
- N Flame heater fuel supply elbow assembly.**
- P Bracket, throttle return spring**
- Q Fuel injection supply pump inlet elbow.**
- R Overflow valve elbow assembly**
- S Hydraulic head elbow assembly**

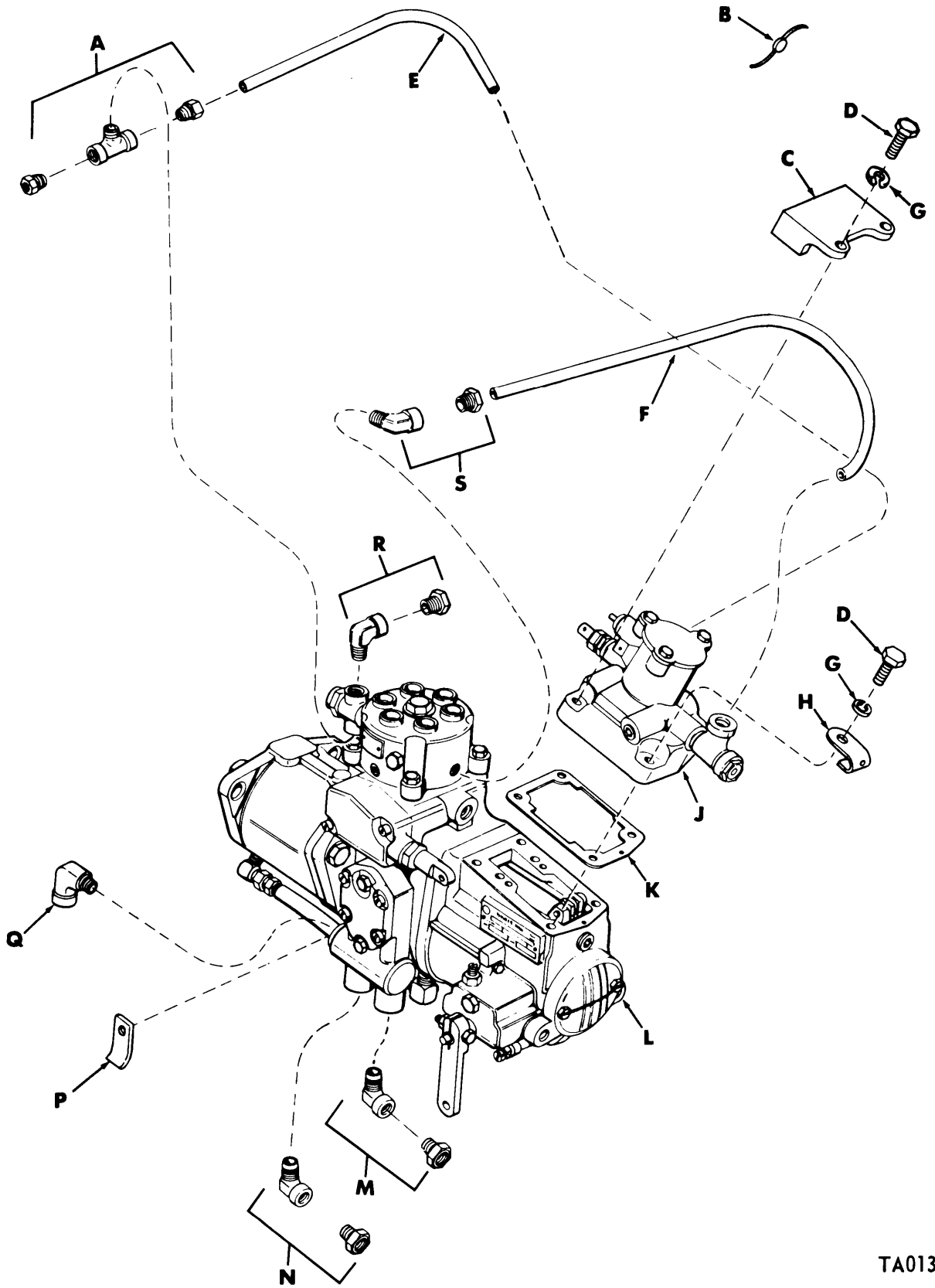

TA013719

Figure 3-30. Code B fuel injection pump assembly, partial exploded view.

KEY to fig 3-31

- A** Overflow valve tee assembly
- B** Lead seal
- C** Tamper proof cover
- D** ¼ inch lockwasher
- E** ¼ x 1¼ capscrew
- F** Fuel density compensator overflow tube.
- G** Fuel density compensator to hydraulic head tube.
- H** Clip, engine stop cable
- J** Compensator assembly gasket
- K** Fuel injection pump assembly
- L** Fuel injection supply pump outlet elbow assembly.
- M** Fuel injection supply pump inlet elbow.
- N** Flame heater fuel supply tube union assembly.
- P** Overflow elbow assembly
- Q** Hydraulic head elbow assembly
- R** Fuel density compensator assembly.

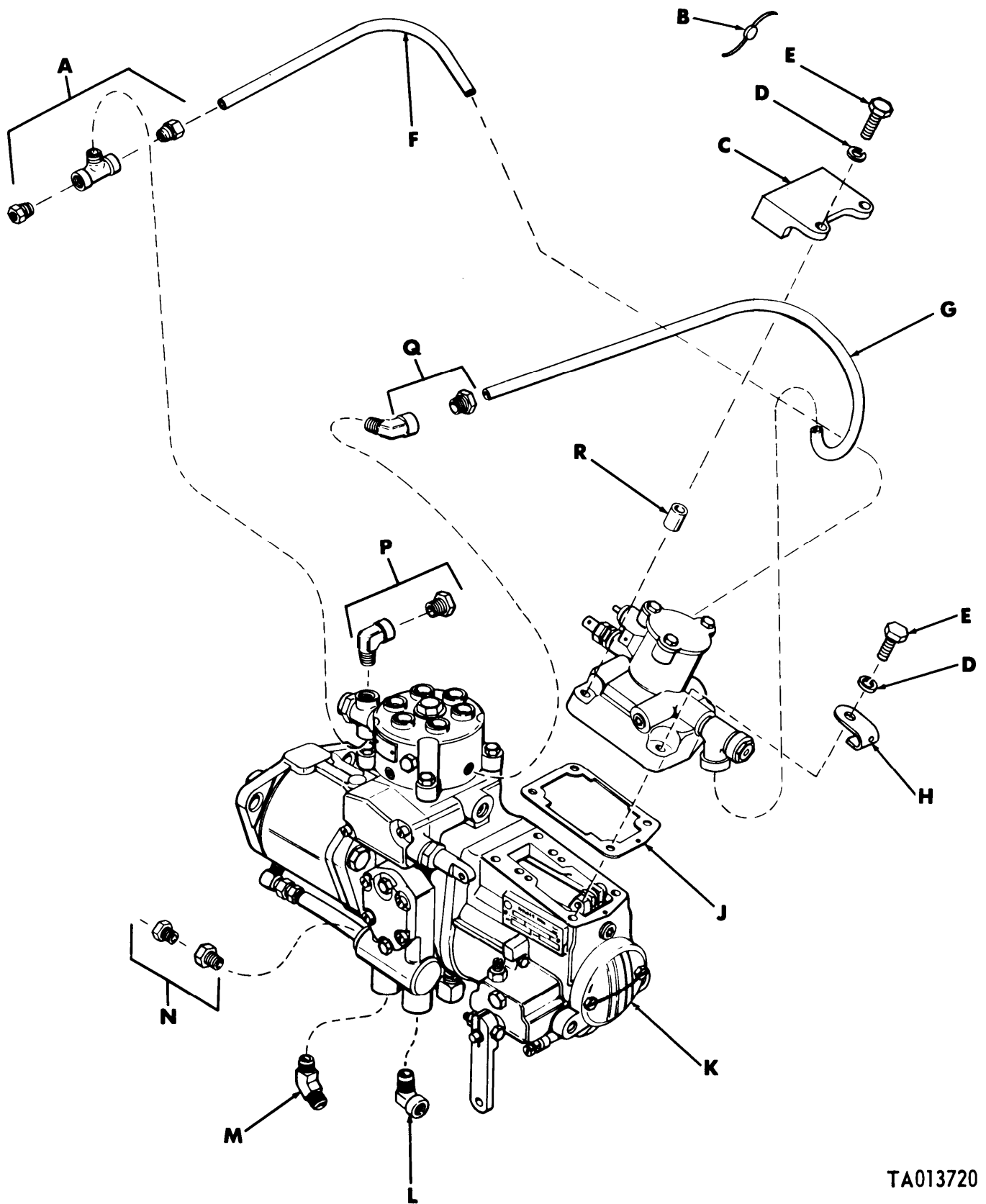
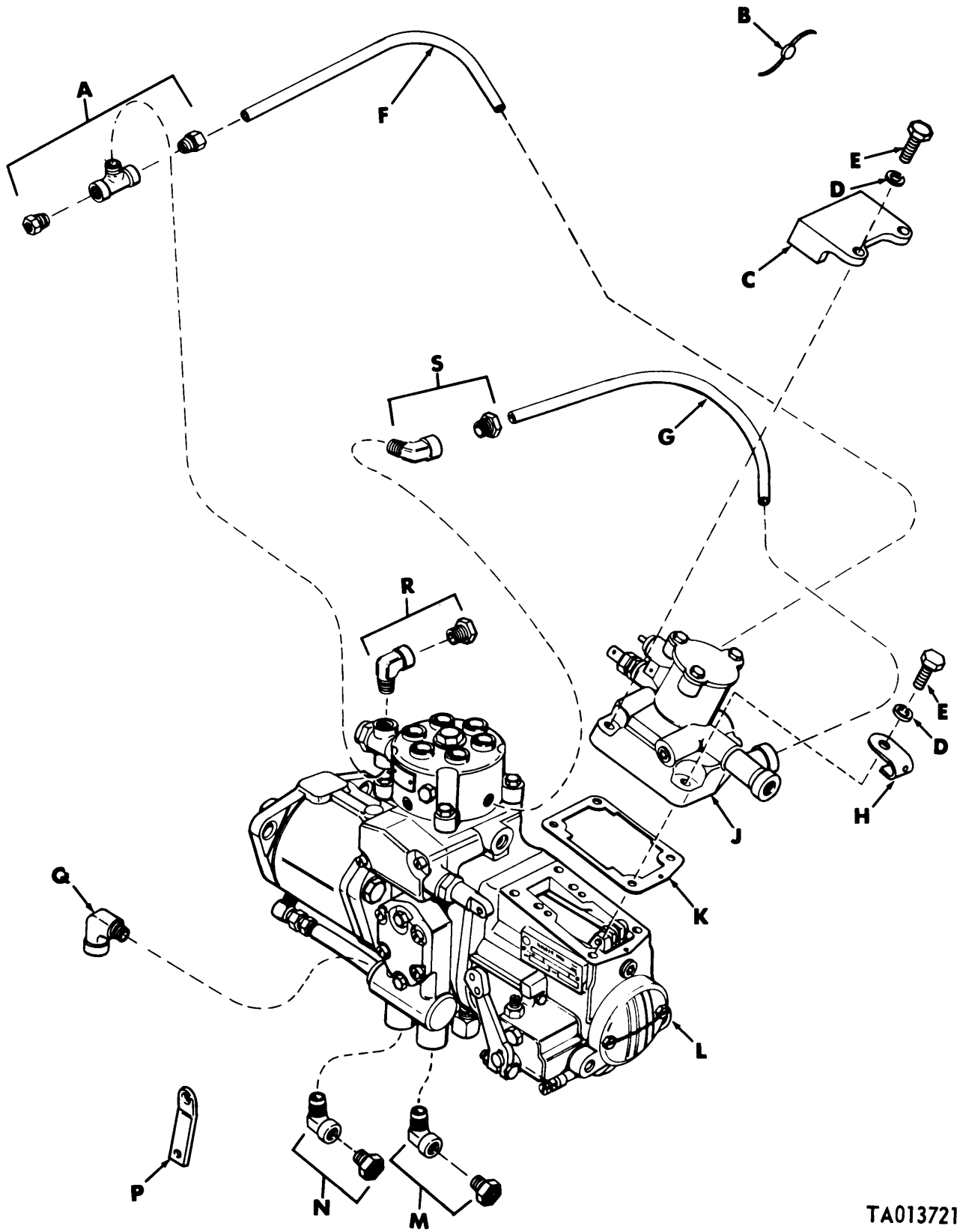

Figure 3-31. Code C, D and E fuel injection pump assemblies, partial exploded view

TA013720

KEY to fig 3-32

- A Overflow valve tee assembly**
- B Lead seal**
- C Tamper proof cover**
- D ¼-inch lockwasher**
- E ¼ x 1¼ capscrew**
- F Fuel density compensator overflow tube.**
- G Fuel density compensator to hydraulic head tube.**
- H Clip, engine stop cable**
- J Compensator assembly**
- K Compensator assembly gasket**
- L Fuel injection pump assembly**
- M Fuel injection pump outlet elbow assembly.**
- N Fuel injection supply pump inlet elbow.**
- P Bracket**
- Q Flame heater fuel supply elbow assembly.**
- R Overflow valve elbow assembly**
- S Hydraulic head elbow assembly**



TA013721

Figure 3-32. Late code F fuel injection pump assembly, partial exploded view.

KEY to fig 3-33

- A Overflow valve tee assembly**
- B Fuel density compensator overflow tube.**
- C Overflow tube elbow assembly**
- D Lead seal**
- E $\frac{1}{4}$ x $1\frac{1}{4}$ capscrew**
- F $\frac{1}{4}$ -inch lockwasher**
- G Tamper proof cover**
- H $\frac{1}{4}$ x $1\frac{3}{4}$ capscrew**
- J Clip**
- K Pipe to hose tee**
- L Fuel density compensator to hydraulic head hose assembly.**
- M Compensator assembly gasket**
- N Fuel injection pump assembly.**
- P Fuel injection pump outlet elbow.**
- Q Bracket**
- R Flame heater fuel supply elbow assembly.**
- S Hydraulic head elbow**
- T Fuel density compensator assembly.**
- U Tamper proof cover spacer**

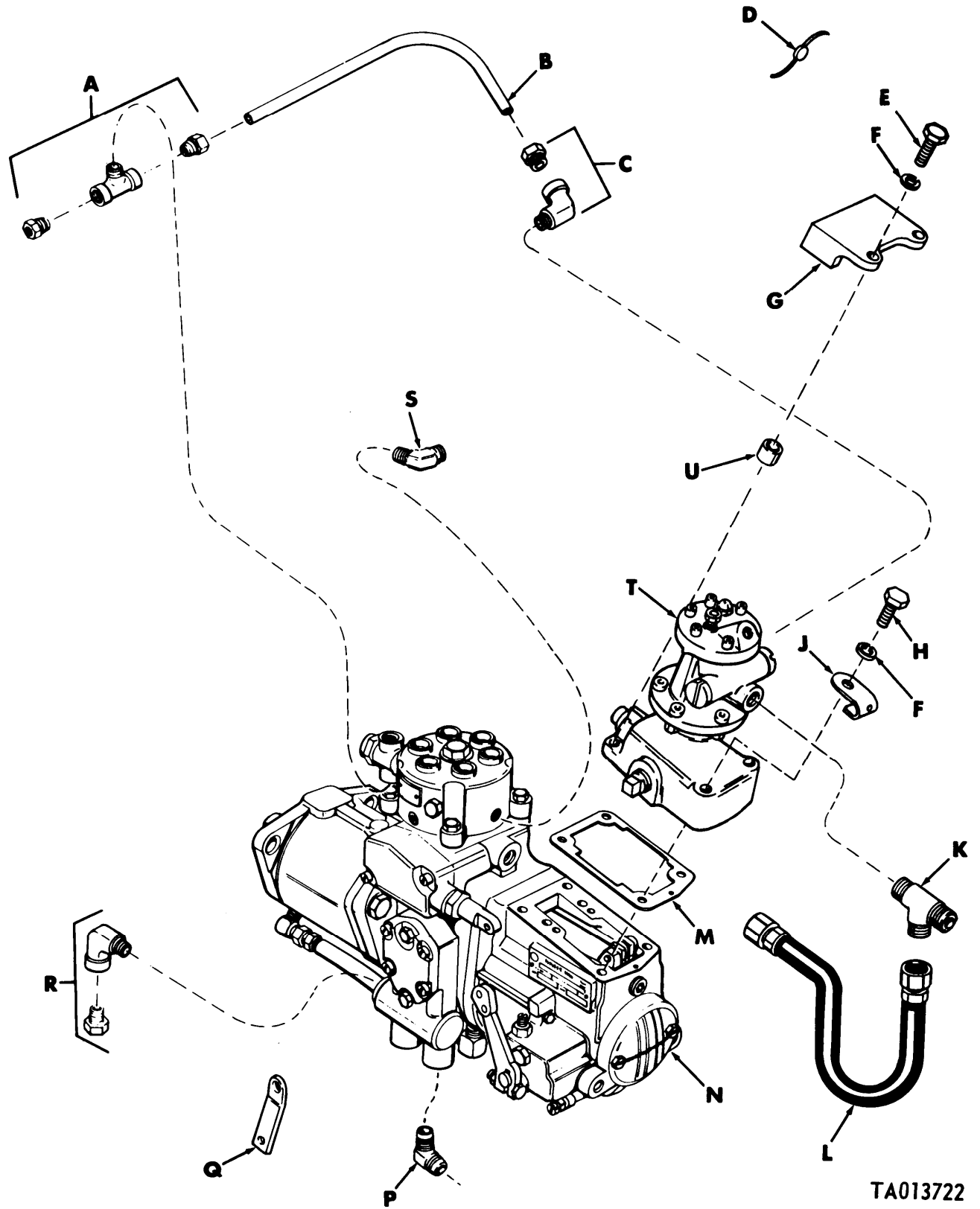

TA013722

Figure 3-33. Early code F fuel injection pump assembly, partial exploded view.

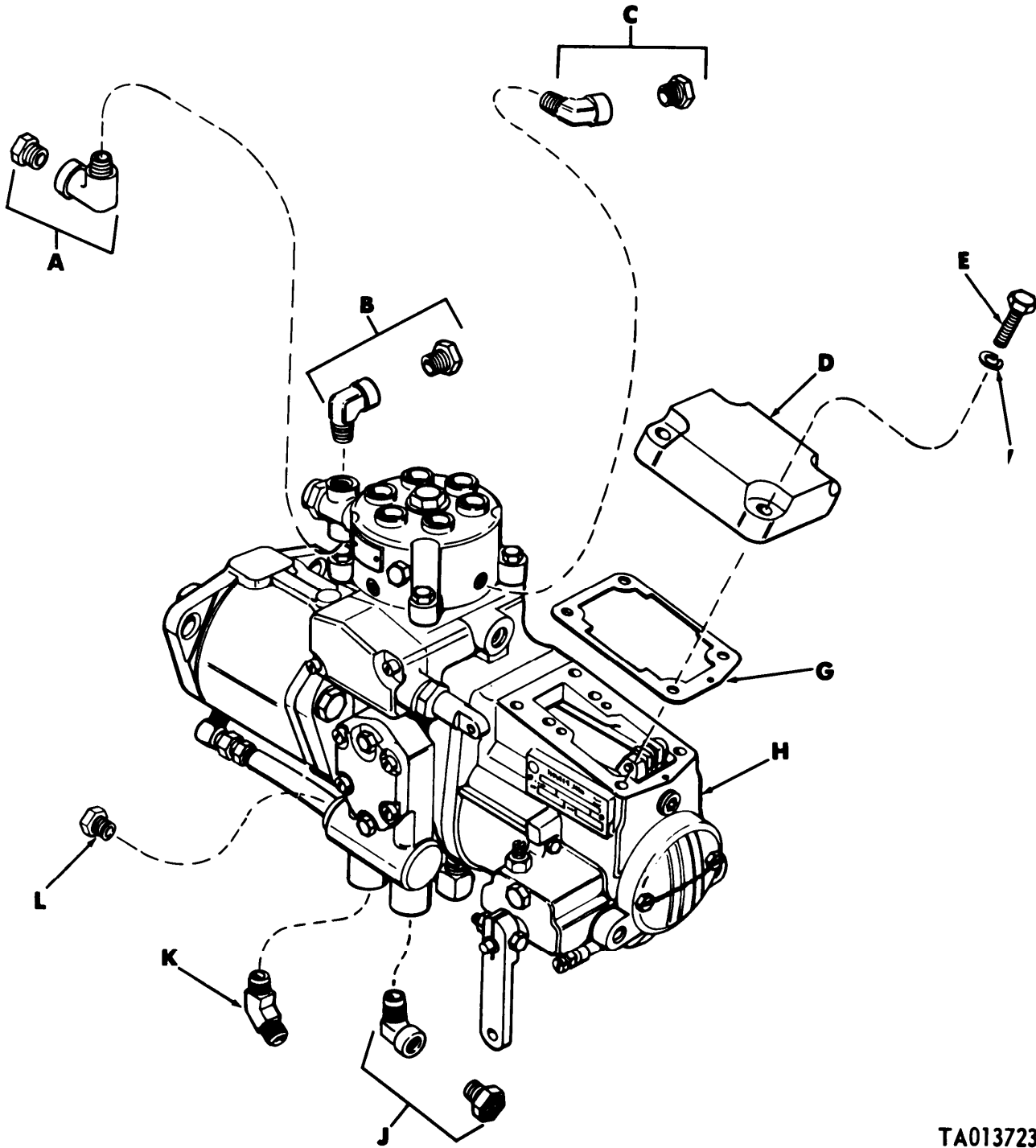

TA013723

- | | |
|---|---|
| <p>A Overflow valve elbows (nozzle return) assembly.
 B Overflow valve elbow (pump return) assembly.
 C Hydraulic head elbow assembly
 D Governor cover
 E 1/4x7/8 cap screw
 F 1/4-inch lockwasher</p> | <p>G Governor cover gasket
 H Fuel injection pump assembly
 J Fuel injection supply pump outlet elbow assembly.
 K Fuel injection supply pump inlet elbow.
 L 1/4 -inch pipe plug</p> |
|---|---|

Figure 3-34. Late code G fuel injection pump assembly, partial exploded view.

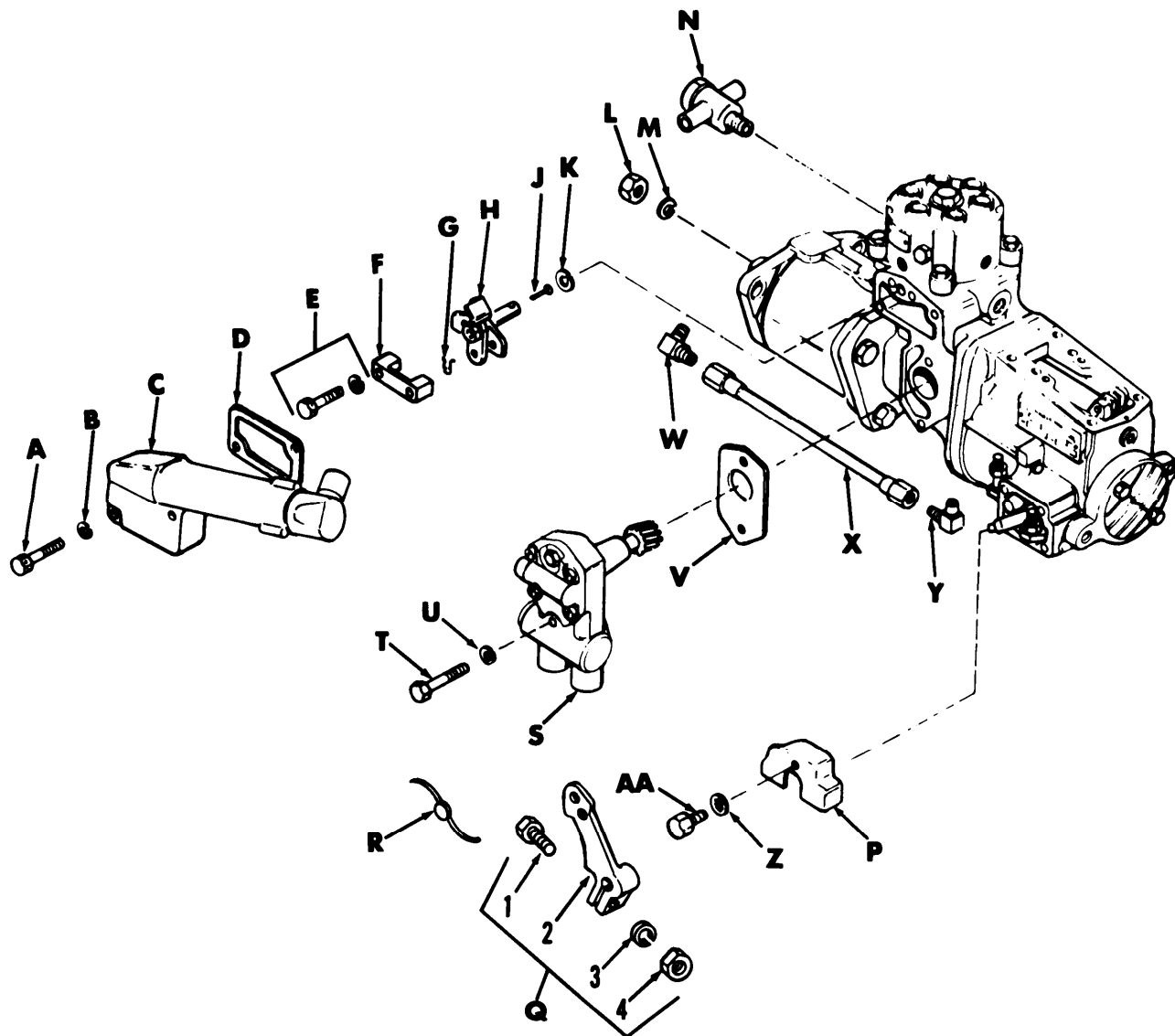

TA013724

- A 1/4x1 1/4 fillister head screw.
- B 1/4-inch lockwasher
- C Solenoid assembly
- D Solenoid housing gasket
- E Assembled washer screw
- F Control unit retainer
- G Retaining pin
- H Control unit assembly
- J Plunger sleeve pin
- K Preformed packing

- L 9/16-inch plain nut
- M 9/16-inch lockwasher
- N Overflow valve assembly
- P Upper dust cover
- Q Operating lever assembly
 - 1 Lever clamping screw
 - 2 Operating lever
 - 3 3/4-inch lockwasher
 - 4 1/4-inch nut
- R Governor lead seal

- S Fuel supply pump assembly
- T 1/4 x 1 1/4 machine screw
- U 1/4-inch lockwasher
- V Fuel supply pump gasket
- W Pipe to tube tee
- X Oil hose assembly
- Y 90° elbow
- Z No. 12 lockwasher
- AA No. 12 x 3/8 machine screw

Figure 3-35. Code A fuel injection pump assembly, partial exploded view.

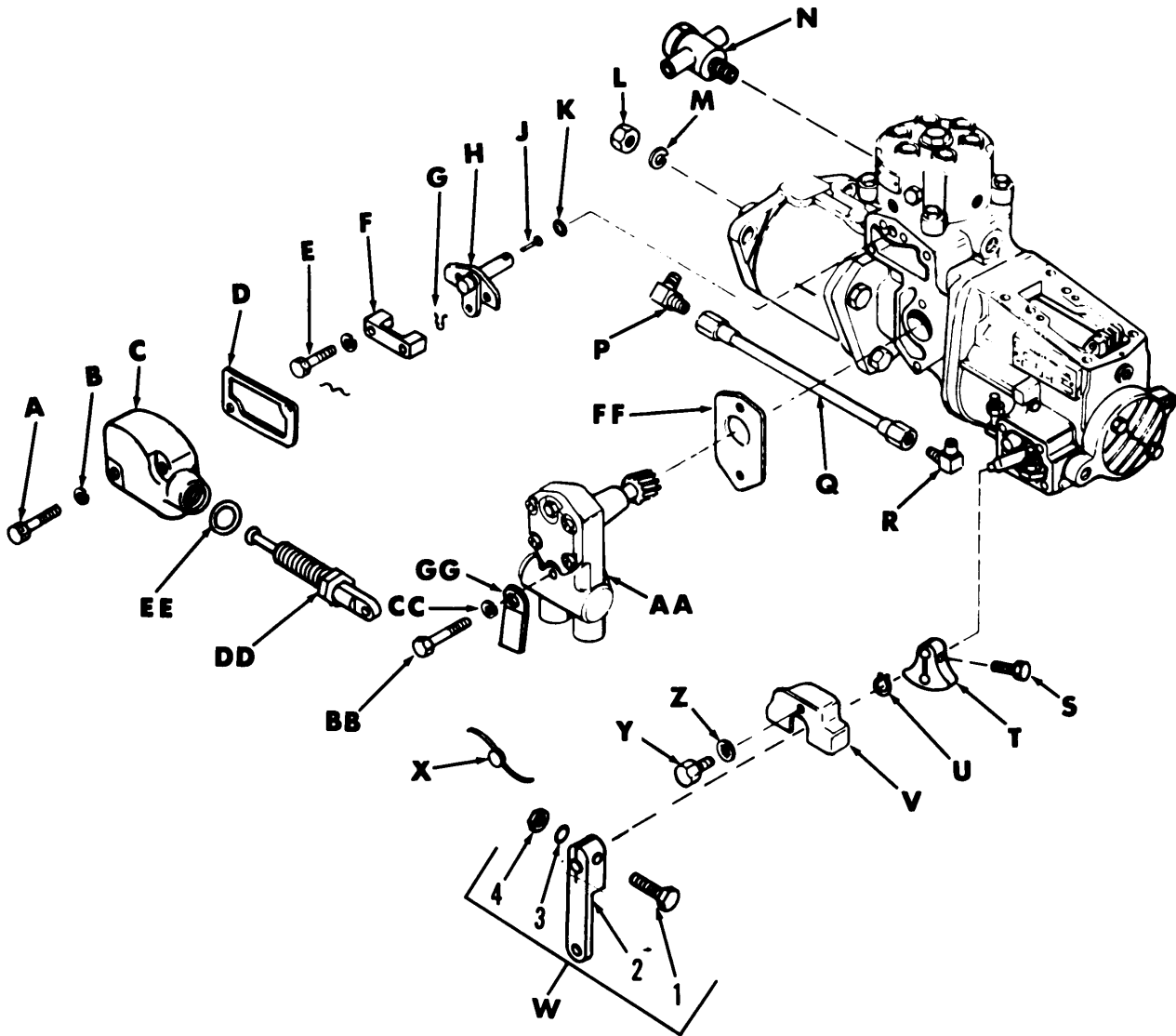

TA013725

- A ¼x1¼ fillister head screw.
- B ¼-inch lockwasher
- C Timing window cover
- D Timing window cover gasket
- E Assembled washer screw
- F Control unit retainer
- G Retaining pin
- H Fuel control unit assembly
- J Plunger-sleeve pin
- K Preformed packing
- L 9/16-inch plain nut
- M 9/16-inch lockwasher
- N Overflow valve assembly
- P Pipe-to-tube tee
- Q Oil hose assembly
- R 90° elbow
- S Operating lever stop screw
- T Operating lever stop
- U Retaining ring
- V Upper dust cover
- W Operating lever assembly
 - 1 Lever clamping screw
 - 2 Operating lever
 - 3 ¼-inch lockwasher
 - 4 ¼-inch nut
- X Governor lead seal
- Y No. 12 x 3/8 machine screw
- Z No. 12 lockwasher
- AA Fuel supply pump assembly
- BB ¼x1¼ machine screw
- CC ¼-inch lockwasher
- DD Fuel shutoff rod assembly
- EE Shutoff rod gasket
- FF Fuel supply pump gasket
- GG Bracket engine throttle control (code B pump only).

Figure 3-36. Code B, C, D and F fuel injection pump assemblies, partial exploded view.

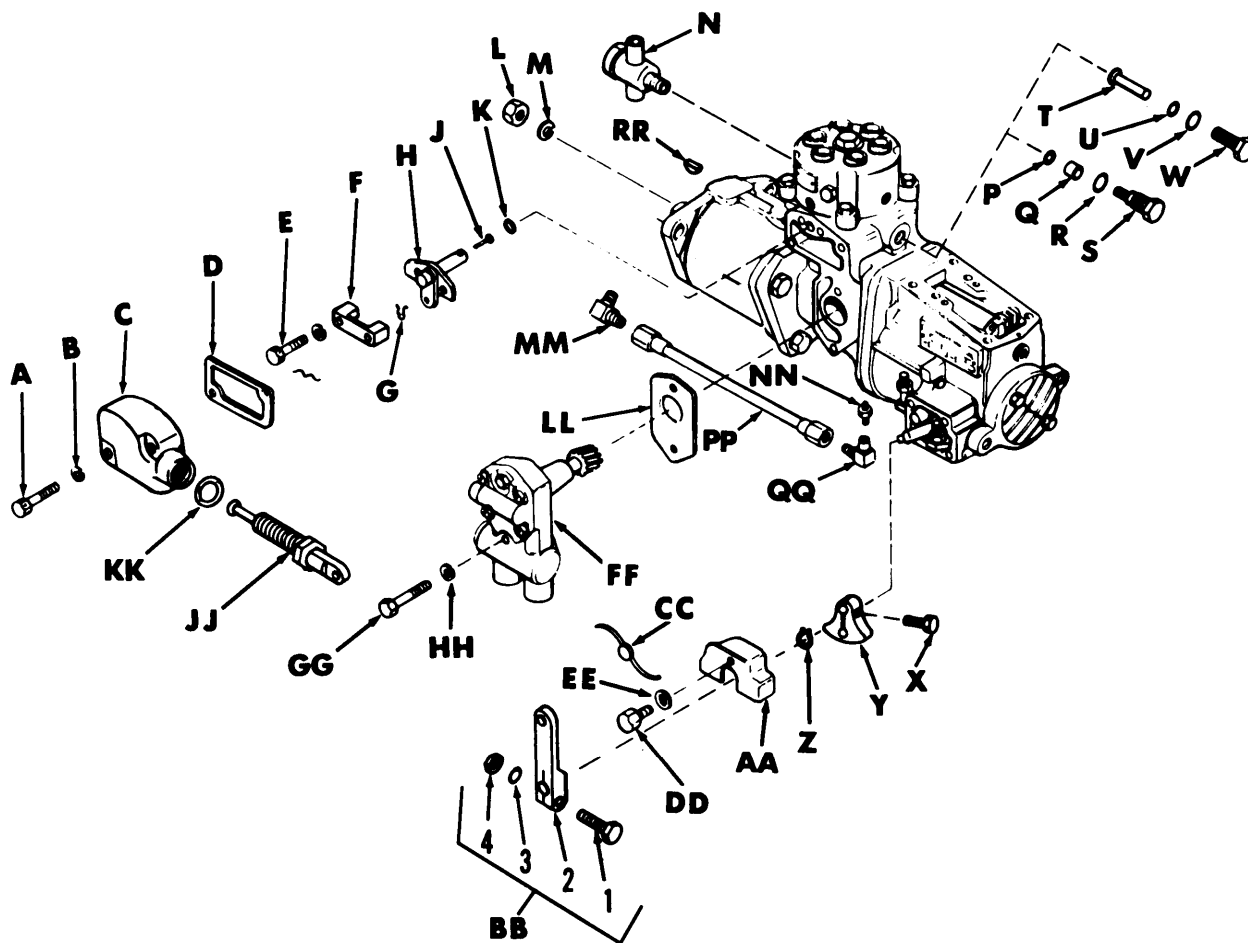

TA013726

- | | |
|--|--|
| <p>A ¼x1¼ fillister head screw.
 B ¼-inch lockwasher
 C Timing window cover
 D Timing window cover gasket
 E Assembled washer screw
 F Control unit retainer
 G Retaining pin
 H Fuel control unit assembly
 J Plunger sleeve pin
 K Preformed packing
 L 9/16-inch plain nut
 M 9/16-inch lockwasher
 N Overflow valve assembly
 P Preformed packing
 Q Oil filter
 R Filter screw copper gasket
 S Oil filter screw
 T Pin
 U Preformed packing
 V Gasket
 W Screw
 X Operating lever stop screw</p> | <p>Y Operating lever stop
 Z Retaining ring
 AA Upper dust cover
 BB Operating lever assembly
 1 Lever clamping screw
 2 Operating lever
 3 ¼-inch lockwasher
 4 ¼-inch nut
 CC Governor lead seal
 DD No. 12x3/8 machine screw
 EE No. 12 lockwasher
 FF Fuel supply pump assembly
 GG ¼x1¼ machine screw
 HH ¼-inch lockwasher
 JJ Fuel shut-off rod assembly
 KK Shutoff rod gasket
 LL Fuel supply pump gasket
 MM Pipe to tube tee
 NN Pipe nipple
 PP Oil hose assembly
 QQ 90° elbow
 RR Woodruff key</p> |
|--|--|

Figure 3-37. Code F and G injection pump assemblies, partial exploded view.

3-18. Cleaning and Inspection. *a. Cleaning.* Immerse and clean all parts in dry-cleaning solvent, specifications PS-661, and dry with compressed air. Cover parts with a clean lint-free cloth and keep all parts clean until assembly. Clean all fuel and oil

passages thoroughly. Refer to TM 9-214 for care and maintenance of antifriction bearings.

b. Inspection and Repair. Examine all threaded parts for worn or damaged threads. Minor thread

damage can be repaired with a used tap or die. Replace all threaded parts that are beyond repair.

3-19. Inspection of Overflow Valve Assembly. Inspect the overflow valve threads for damage and inspect valve for cracks. Replace the complete overflow valve assembly if damaged. Refer to figures 3-38, 3-39 and 3-40 for selection of replacement overflow valves. Both used and new valves will be functionally inspected at pump calibration and test as outlined in paragraph 3-58b.

3-20. Repair of Fuel Supply Pump Assemblies. a. Selection of Replacement Fuel Supply Pumps.

(1) The following list identifies the various fuel supply pumps used with the injection pumps.

(2) Figure 3-41 illustrates and helps to identify the fuel supply pumps.

<i>Fuel Injection Pump</i>	<i>Fuel Supply Pump</i>
Code A (2910 -178-1 115)	4320-908-6322
Code B (2910-908-6320)	4320-908-6321
Code C, D and E (2910-759-5410)	4320-908-6321
Code F (2910-017-9778)	4320-999-2276
Code G (early, late and rebuild, (2910-860-2333 or 2910-966-6317).	2910-871-5428 or 4320-908.6321.

(3) Refer to figure 3-41 to distinguish the fuel supply pump identifying features.

(a) Supply pump- 4320-908-6322 has relief valve in pump gear cover and relief valve housing is stamped 80 PSI.

(b) Supply pump- 4320-908-6321 has a flat pump gear cover and check valve screw has 1/4-NPT tapped hole.

(c) Supply pump- 320-999-2276 has relief valve in pump gear cover and relief valve housing is stamped 60 PSI.

(d) Supply pump-2910-871-5428 has a flat pump gear cover and check valve screw does not have tapped hole.

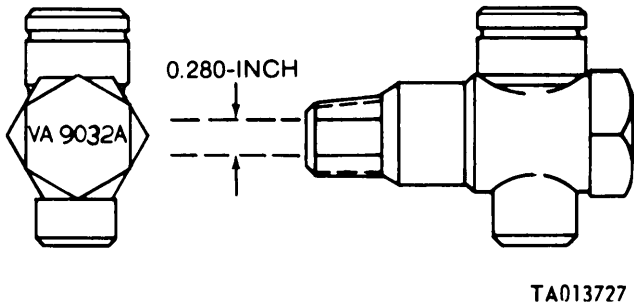

Figure 3-38. Overflow valve assembly (code A, B, C, D and E pumps).

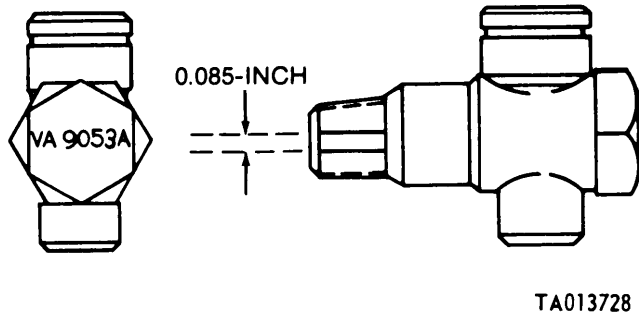

Figure 3-39. Overflow valve assembly (code F pump).

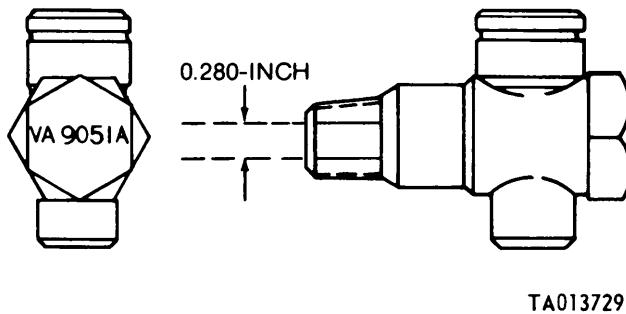
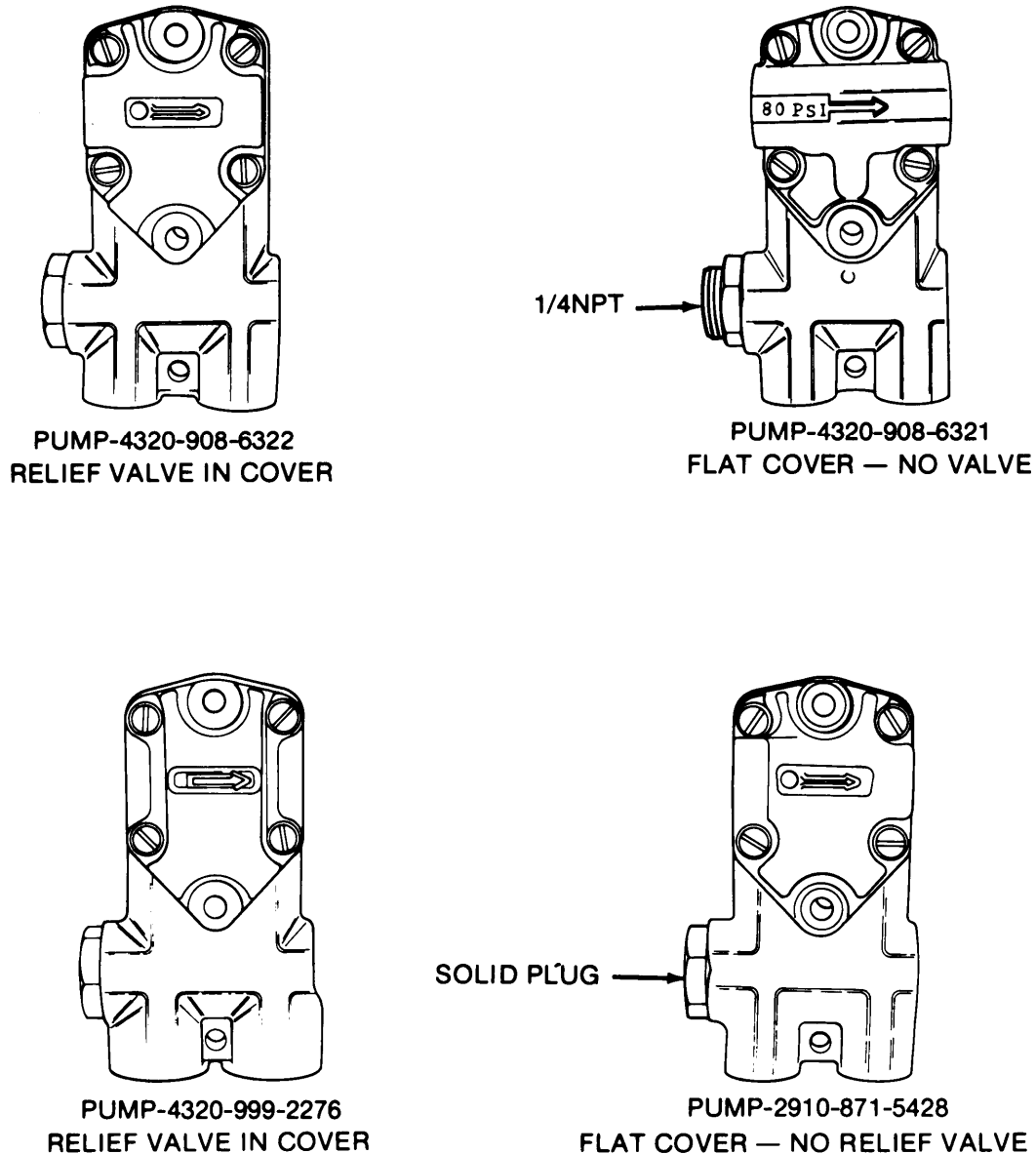

Figure 3-40. Overflow valve assembly (code G pump).



TA013730

Figure 3-41. Fuel supply pump identification.

NOTE

Components of the fuel supply pump assemblies are not spare part items except for a seal repair kit- 2910-489-5994. Perform the following test and inspection to determine if the supply pump is serviceable, needs a seal kit or needs replacement.

b. Test. Plug all openings except the fuel inlet. Using an auxiliary fuel supply, pressurize pump to 60 psi minimum, and examine for fuel leaks, paying particular attention to the pump housing oil seal. If the housing oil seal leaks, install the seal repair kit as outlined in step *d.* below.

c. Inspection.

(1) Inspect the pump housing for cracks, thread darn age, loose idler gear pin (R), or other evidence of fuel leakage. If the threads cannot be repaired using a suitable thread tap, replace the complete assembly.

(2) Inspect the fuel pump drive gear (B) fig. 3-43 for evidence of wear or other damage. Replace the complete pump assembly if either condition exists.

d. Installation of the Seal Repair Kit.

(1) Refer to figure 3-42. Remove four fillister head screws (A), lockwashers (B) and housing cover (C).

(2) Refer to figure 3-43. Remove retaining ring (A) using suitable pliers. Remove camshaft drive gear (B), Woodruff key (J), drive shaft (E), and idler gear (D). Remove and discard housing oil seal (C).

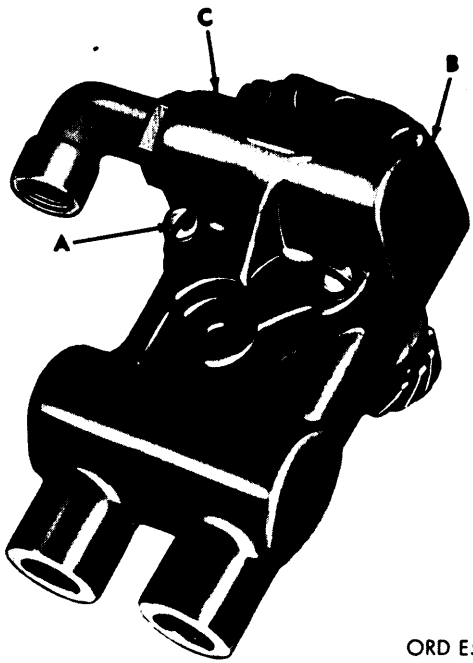

ORD E57074

Figure 3-42. Removing or installing housing cover.

KEY to fig 3-43

- A Retaining ring
- B Fuel pump drive gear
- C Housing oil seal
- D Idler gear
- E Drive shaft
- F Housing cover
- G 3/16-inch lockwasher
- H 3/16x1/2 fillister head screw
- J Woodruff key
- K Pump housing
- L Check valve spring
- M Check valve
- N Valve screw gasket
- P Preformed packing
- Q Valve screw
- R Idler gear pin

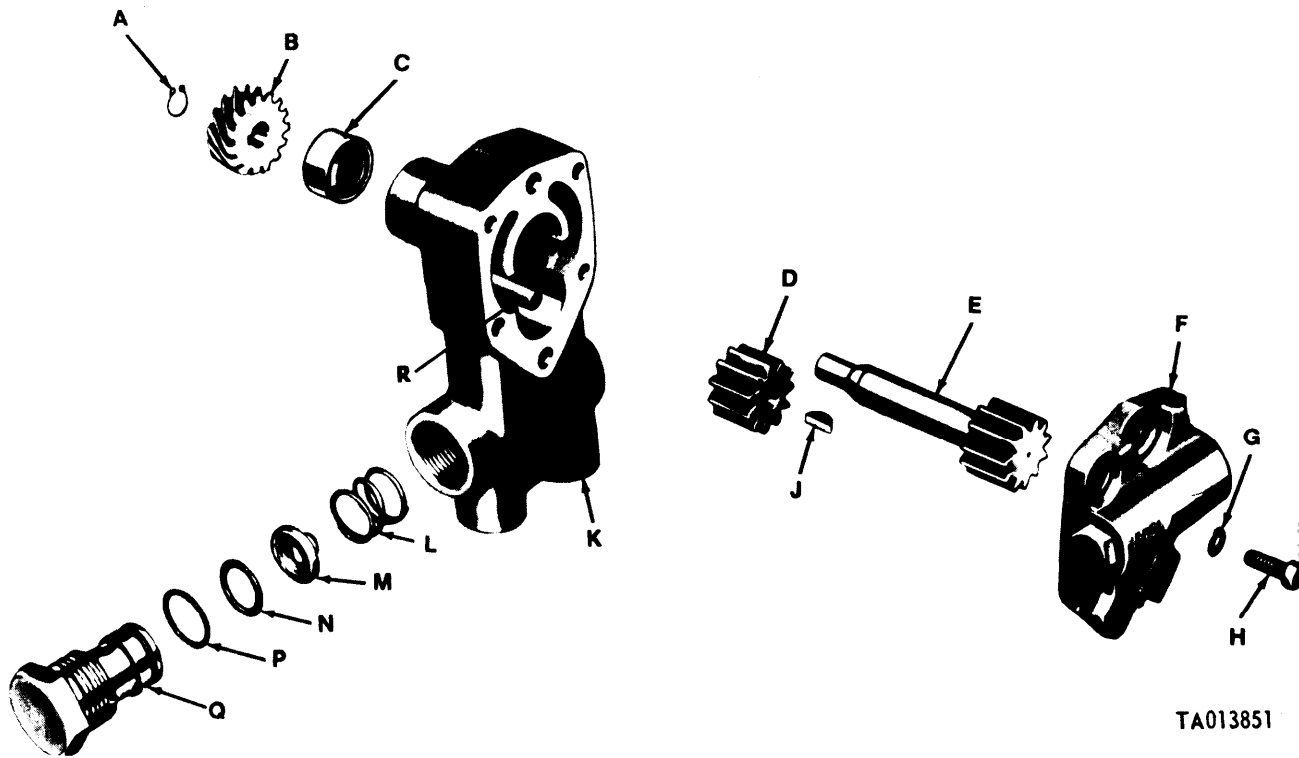

TA013851

Figure 3-43. Fuel supply pump, exploded view.

(3) Check the disassembled components of the fuel supply pump against the repair standards para 3-62. Replace the complete pump assembly if they do not meet these requirements. Refer to figure 3-43. Examine the supply pump housing(K) and housing cover(F) for cracks and distortion. Inspect the idler gear (D) and the gear on drive shaft (E) for broken or chipped gears and looseness of idler gear pin (R). Replace the complete pump assembly if any of the parts are damaged.

(4) Refer to figure 3-44. Apply a thin coat of sealing compound, MIL-S-45180, or equivalent to the outside diameter of the oil seal and press the seal into the supply pump housing flush to 0.015 inch below supply pump housing face.

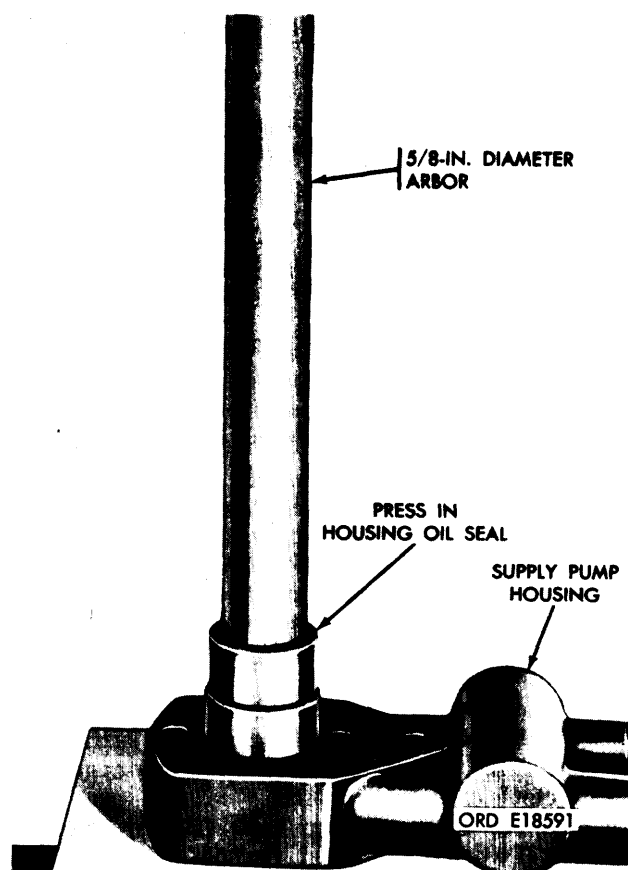
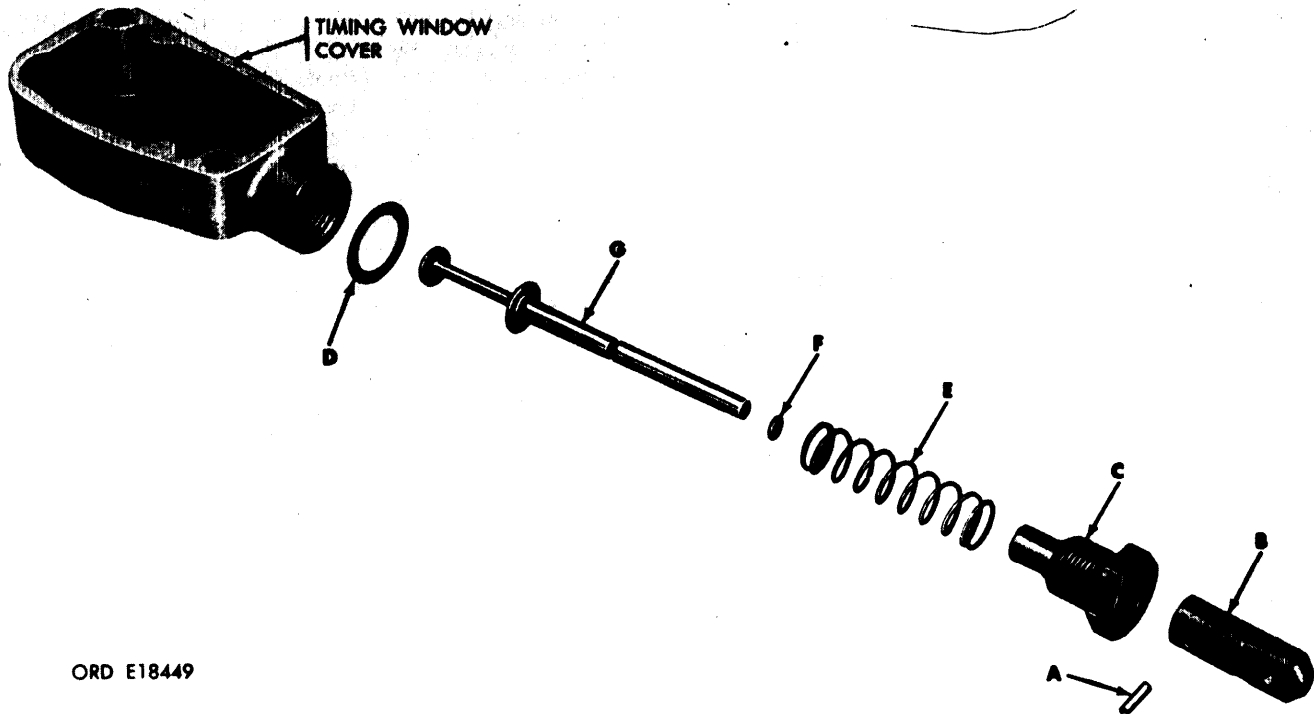

Figure 3-44. Installing fuel supply pump housing oil seal.

(5) Refer to figure 3-43. Install idler gear (D) on pin in supply pump housing. Apply engine oil to lip of housing oil seal and install drive shaft (E) in supply pump housing. Clearance between flat surface of gears and housing must be 0.002 to 0.008 - inch. Install the Woodruff key (J). Install drive gear (B) on drive shaft and secure with retaining ring (A). Turn drive shaft by hand. Gears must operate freely without any binding. Apply a thin coat of sealer, MIL-S-45180, to housing cover and install cover (F) on housing. Secure cover with screws (H) and lock-washers (G). Tighten screws to a torque of 30-35 inch -pounds.

e. Final Testing. Final testing of the fuel supply pump is accomplished at fuel injection pump test stand calibration.

3-21. Repair of Timing Window Cover and Fuel Shutoff Rod Assembly (All Except Code A Injection Pumps). *a. Disassembly.* Refer to figure 3-45. Drive out fitting retaining pin (A) using suitable drift. Remove shutoff fitting (B) and bearing screw (C). Remove and discard shutoff rod gasket (D). Remove rod return spring (E). Remove and discard shutoff rod preformed packing (F). Remove fuel shutoff rod (G) from timing window cover.



ORD E18449

Figure 3-45. Disassembling or assembling timing window cover and fuel shutoff rod assembly.

b. Inspection and Repair. Inspect and repair timing window cover and fuel shutoff rod assembly as follows. Check condition of the rod return spring (E, fig. 3-45) and replace the spring when it does not pass visual inspection. Examine the timing window cover for cracks or distortion. Replace the cover when cracked or distorted. Examine the gasket surface of the cover for scratches, nicks, or burs. Repair minor damage with crocus cloth or a fine mill file and replace when it is not repairable. Inspect rod (G) and bearing screw (C) for evidence of wear. Rod must move freely in screw.

c. Assembly. Assemble the fuel shutoff rod assembly and timing window cover as follows. Refer to figure 3-45.

(1) Install shutoff rod preformed packing (F), rod return spring (E), and bearing screw (C) on fuel shutoff rod (G). Compress rod return spring and position shutoff fitting (B) on fuel shutoff rod and align holes in rod and fittings. Drive fitting retaining pin (A) through holes. Stake fitting retaining pin in place.

(2) Position shutoff rod gasket (D) on fuel shutoff rod assembly and install shutoff re assembly in timing window cover.

3-22. Repair of Fuel Shutoff Solenoid Cover Assembly (Code A Injection Pumps).

a. Refer to figure 3-46. Apply 24 v dc to solenoid electrical connection (A) and ground to housing (F) to check for solenoid plunger movement. If plunger (G) does not actuate, replace complete fuel shutoff solenoid cover assembly. If it does operate, complete inspection as follows.

b. Examine the timing window housing portion (F) for cracks or distortion, and mating surface for scratches, nicks, or burs. Repair minor damage with crocus cloth or a fine mill file.

c. Inspect blackout stop shell (B) for wear or damage. If worn or damaged, remove sleeve (E), nut (D), washer (C) and shell (B). Install new shell, washer, nut, sleeve and repeat step *a* above.

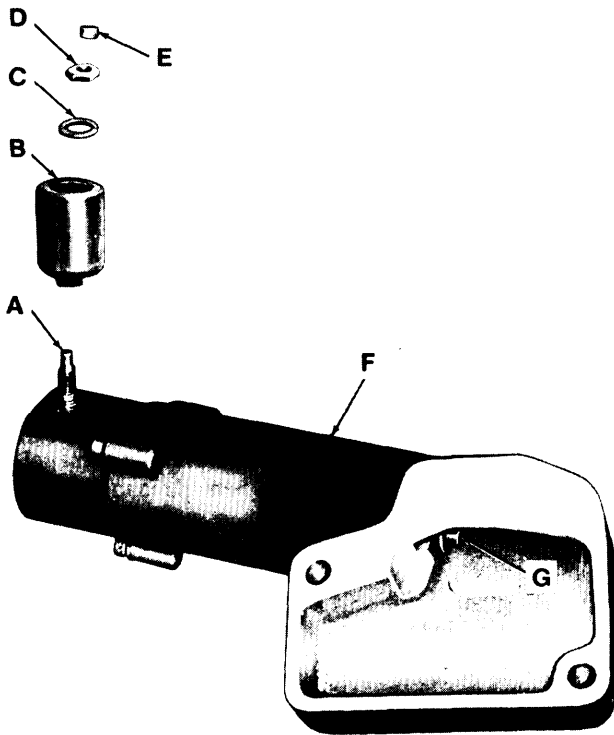

TA013731

Figure 3-46. Fuel shutoff solenoid cover (code A pumps), partial exploded view.

3-23. Repair of Fuel Control Unit Assemblies. *a. Disassembly.* Refer to figure 3-47, remove plunger sleeve pin (A). Remove and discard control unit packing (B).

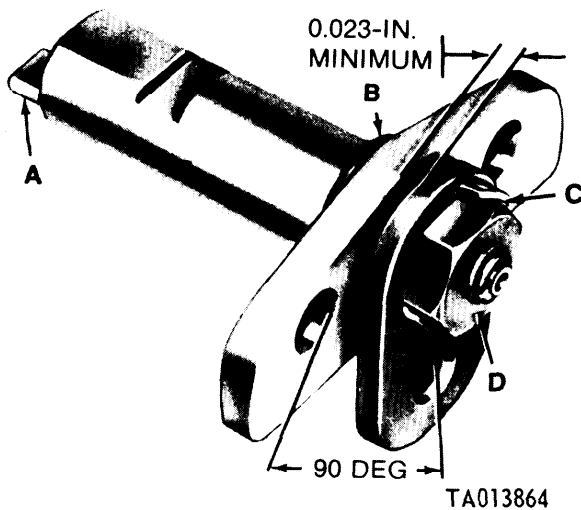

TA013864

Figure 3-47. Checking clearance and movement of fuel control lever.

b. Inspection.

(1) Check the plunger sleeve pin (A) and the inside diameter of the plunger sleeve pin hole against the limits specified in the repair standards (par. 3-60). Replace the pin or the fuel control unit assembly if they do not meet these requirements. Always replace the pin if the control unit assembly is replaced.

(2) Check clearance between lever and control shaft bushing. Clearance must not be less than 0.023 inch. Check movement of lever. Lever must drop freely of its own weight. If not, apply lubricating oil and operate lever until free. If lever does not free up, replace complete assembly. Refer to figures 3-48, 3-49 and 3-50 for identification of replacement control lever units.

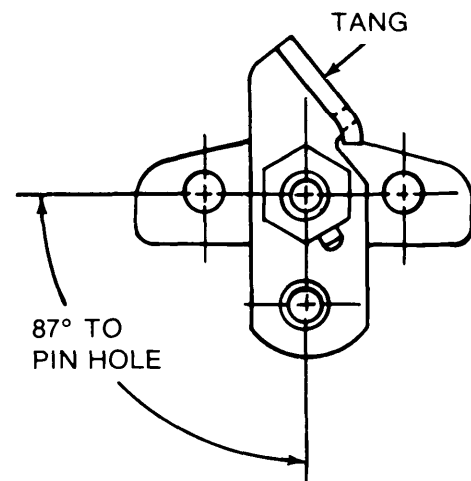

TA013732

Figure 3-48. Fuel control lever identification (code A pump).

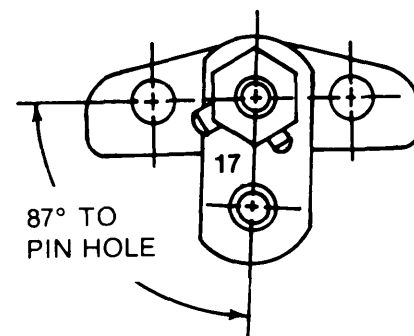

TA013733

Figure 3-49. Fuel control lever identification (code B, C, D, E and F pumps).

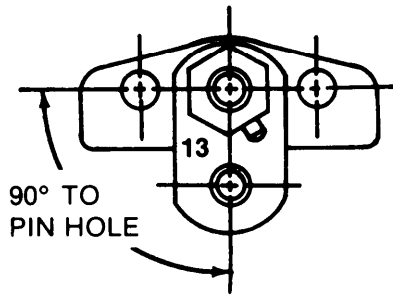

TA013734

Figure 3-50. Fuel control lever identification (code G pump).

(3) Final inspection of the fuel control unit will be accomplished at fuel injection pump calibration
c. Assembly. Refer to figure 3-47 and install plunger sleeve pin (A). Install new control unit packing (B).

3-24. Repair of Fuel Density Compensator Assemblies.

NOTE

There are no service or spare parts for fuel

density compensator assemblies. Do not disassemble.

a. Discard original type (2910-017-9776) and retain other types (2910-907-0665 or 2910-125-3793) for possible reuse.

b. New compensator assemblies are furnished calibrated and do not have to be checked for calibration before installation. If it should be necessary to check operation of a new or used compensator, it may be functionally inspected in the following steps.

(1) Manually operate stop plate (fig. 3-51) through full travel. It must have smooth action with no indication of sticking.

(2) Apply 35-45 psi fuel pressure to compensator fuel inlet (fig. 3-51); and stop plate must move to the , up position.

(3) Manually depress stop plate to full travel. Note that remaining travel, when pressurized is 0.040 to 0.060-inch. This will cover a fuel range of DF-1 and DF-2. If travel is more than 0.060-inch, replace the compensator.

(4) Plug fuel inlet and apply 10 psi fuel pressure to fuel outlet connection (fig. 3-51) and maintain for approximately one minute.

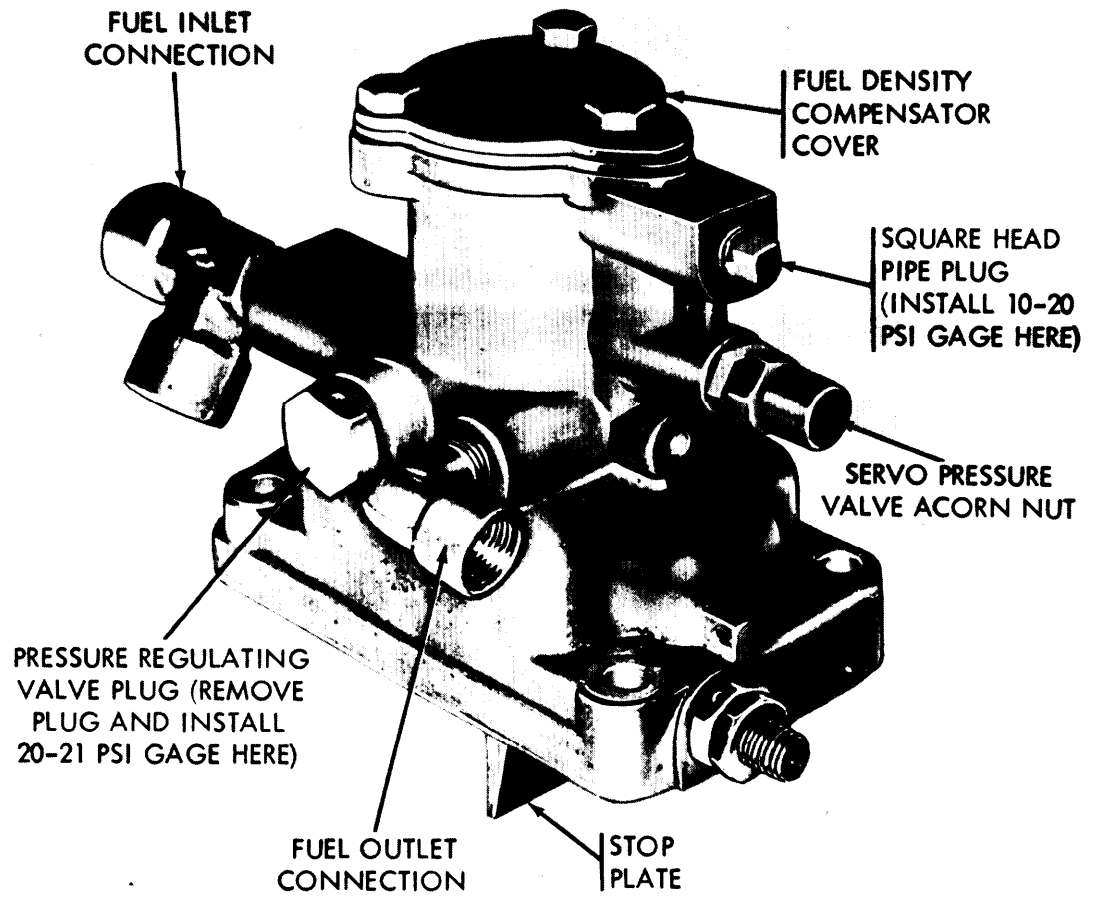

ORD E64580

Figure 3-51. Inspecting fuel density compensator.

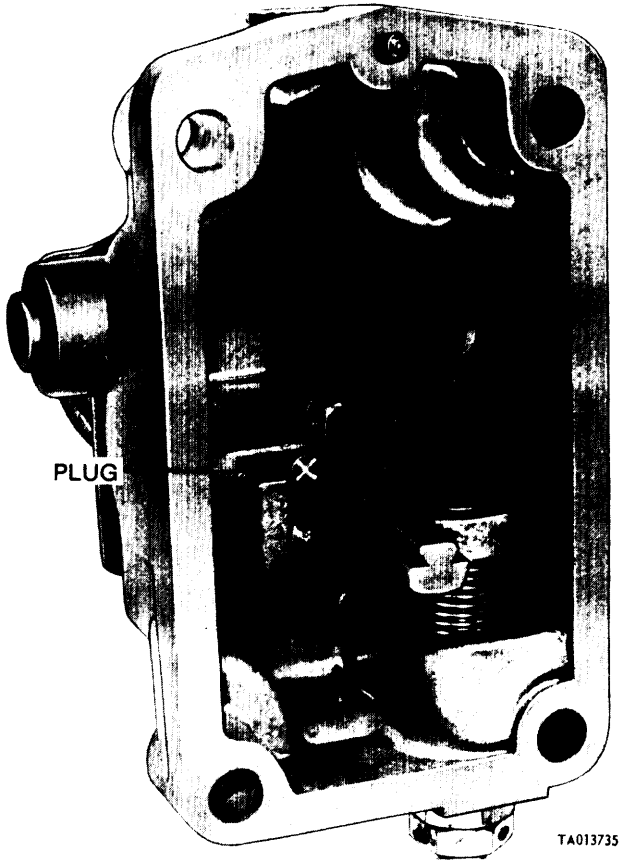

Figure 3-52. Inspecting fuel density compensator brass plug for leakage.

(5) Check compensator for fuel leakage around the piston shaft and at the brass plug under the stop plate guide (fig. 4-52). A trace of fuel is permissible) but if a drop forms, replace the compensator.

(6) If compensator operation meets this test, no further inspection is necessary.

(7) If compensator operation does not meet this test, replace with a new unit.

c. If compensator 2910-907-0665 is equipped with an undrilled link and a push nut in place of drilled link (A), washer (B) and pin (C) fig. 3-53, discard nut and modify link as shown in figure 3-53, by drilling a hole and using the desired washer and pin.

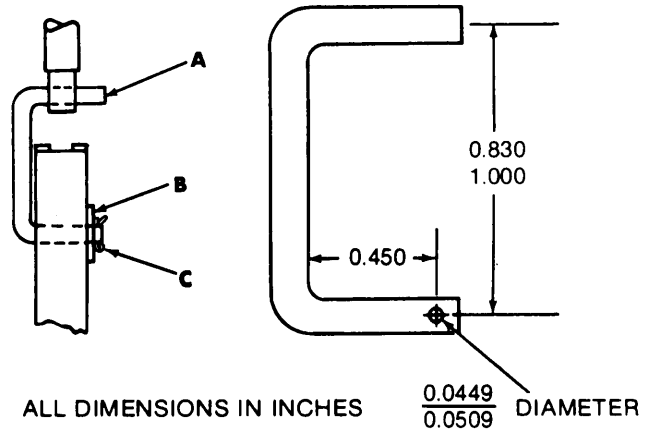

TA013736

Figure 3-53. Modification of fuel density compensator fuel control link.

3-25. Repair of Governor Assembly. a. Disassembly. Disassemble the governor assembly as follows:

(1) Refer to figure 3-54. Cut locking wire (A) and remove two capscrews (B) and lockwashers (C). Remove governor end cap (D). Remove and discard cap gasket (E).

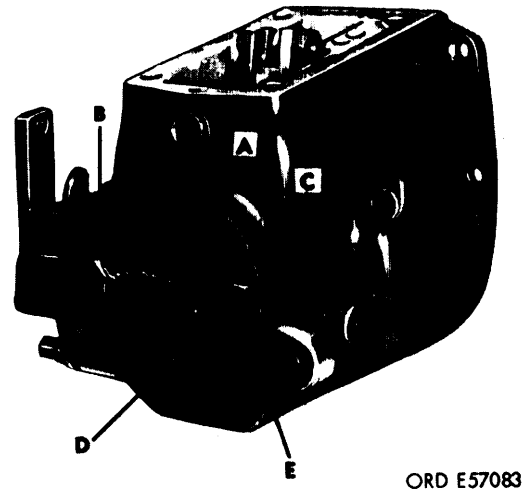
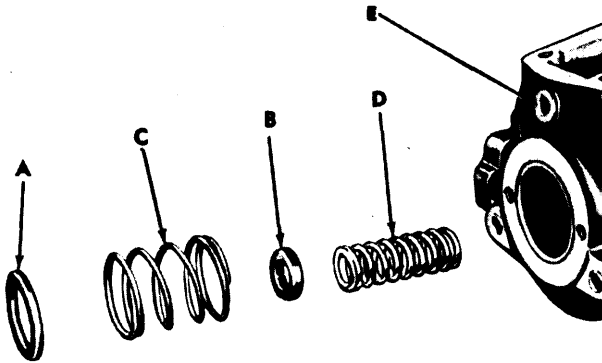

Figure 3-54. Removing governor end cap.

(2) Refer to figure 3-55. Remove outer spring spacer (A), inner spring spacer (B), governor outer spring (C), governor inner spring (D), and pipe plug (E).



ORD E57084

Figure 3-55. Removing inner and outer springs and spacers.

NOTE

Paragraph (3) applies only to code A injection pumps.

(3) Refer to figure 3-56. Unhook torque link spring (A) from torque link (B) and oil baffle (C) and remove spring.

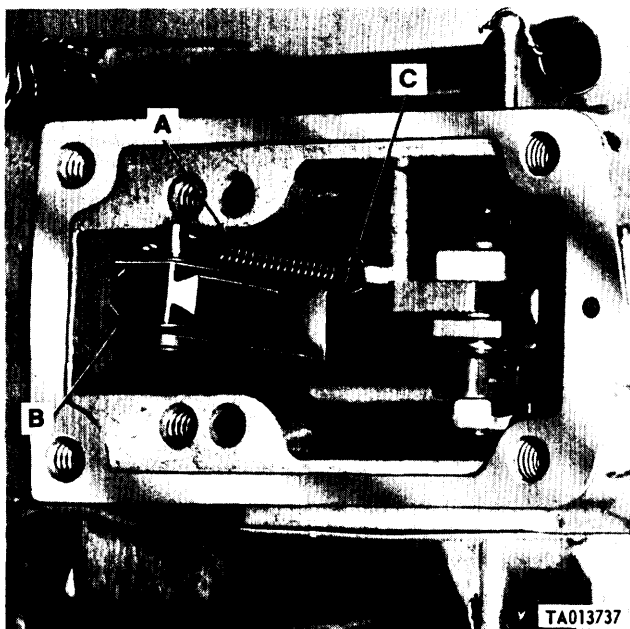
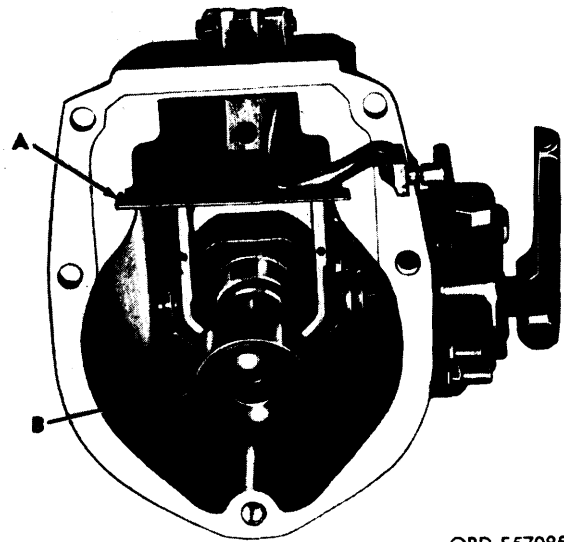

Figure 3-56. Removing torque link spring (Code A pumps).

(4) Refer to figure 3-57. Remove oil baffle (A) and sliding sleeve (B).



ORD E57085

Figure 3-57. Removing oil baffle and sliding sleeve.

NOTE

The operating lever on code A pumps and early code G pumps is a one-piece lever; all others are two-piece. Discard all one-piece levers on early code G pumps and replace with two-piece lever.

(5) Refer to figure 3-58 or 3-59. Remove the lead seal (A). Remove machine bolts (B), lockwashers (C) and dust cover (D). Remove nut (E), lockwasher (F), and clamping screw (G). Remove operating lever (H).

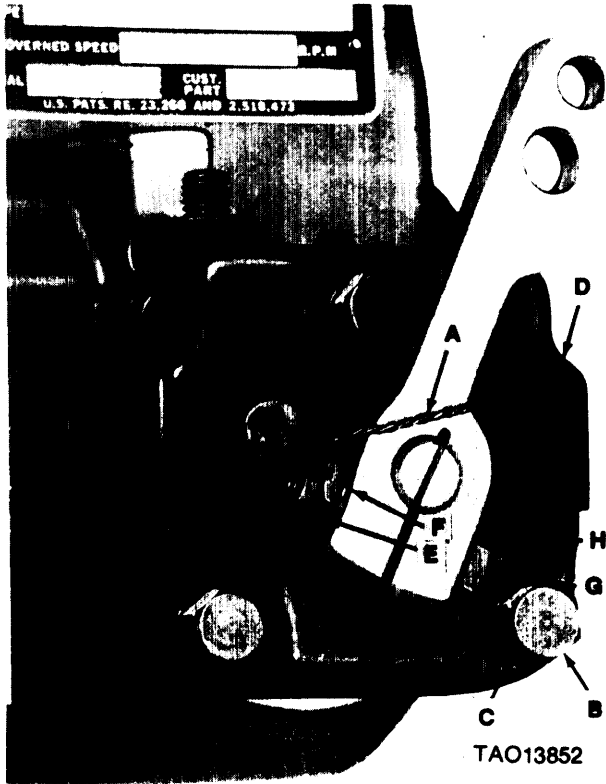

Figure 3-58. Removing dust cover and operating lever—two-piece.

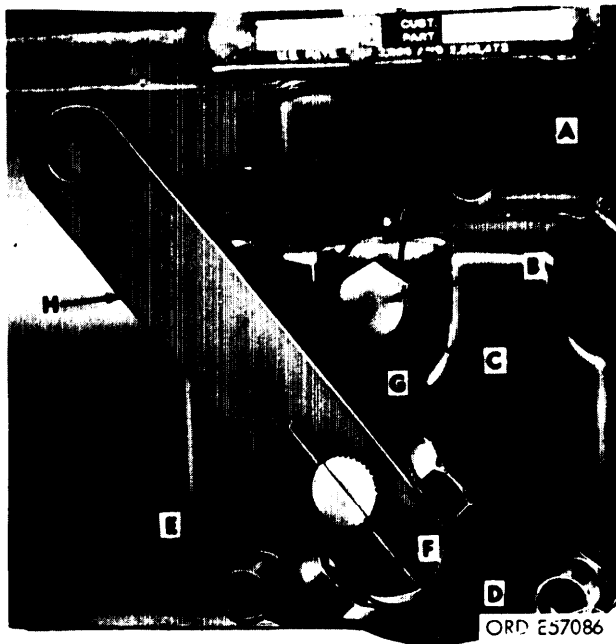

Figure 3-59. Removing dust cover and operating lever—one-piece.

(6) Refer to figure 3-60. Loosen locknuts (B and D). Remove idle adjustment screw (A) and locknut (B), high speed adjustment screw (C), and locknut (D).

NOTE

Sub-paragraph (7) below does not apply to code A or early code G pumps.

(7) Remove retaining ring (E, fig. 3-60) using suitable pliers. Remove clamping screw (F) and stop lever (G).

(8) Refer to figure 3-60. Cut locking wire (H) and remove four bearing mounting machine screws (J). Remove and discard four gaskets (K).

NOTE

Code F injection pumps were equipped with two bearing mounting studs. At disassembly these should be discarded and replaced with machine screws.

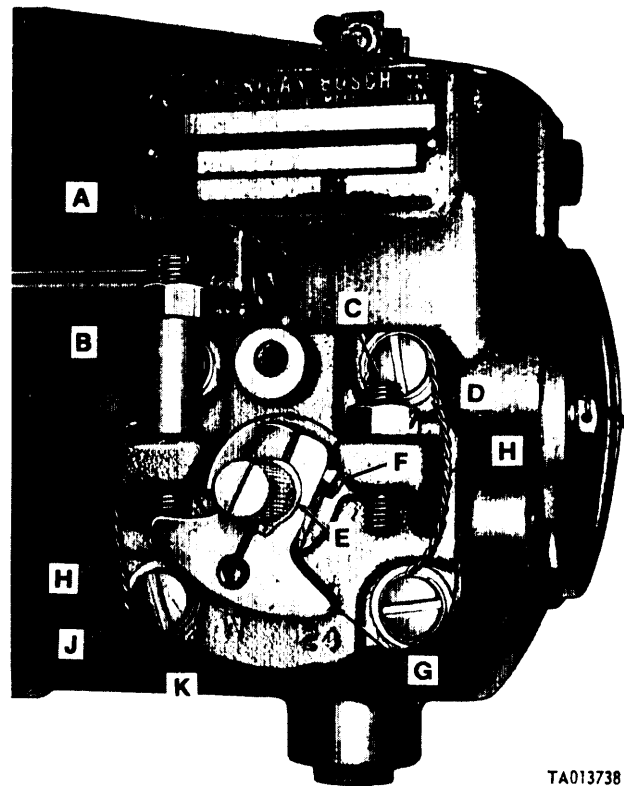

Figure 3-60. Removing adjustment screws, stop lever, operating shaft and associated parts.

NOTE

Paragraphs (9), (10) and (11) do not apply to code A injection pumps.

(9) Refer to figure 3-61. Remove operating shaft and bearing (A) and associated parts. Remove and discard operating shaft bearing gasket (B).

(10) Refer to figure 3-62. Remove operating shaft (E), operating-shaft spring (B), and shaft spring plate (C) from bearing (A). See note. Remove and discard operating shaft preformed packing (D).

NOTE

If a code G pump operating shaft does not have a retaining ring groove, discard the shaft and replace with a new shaft at assembly.

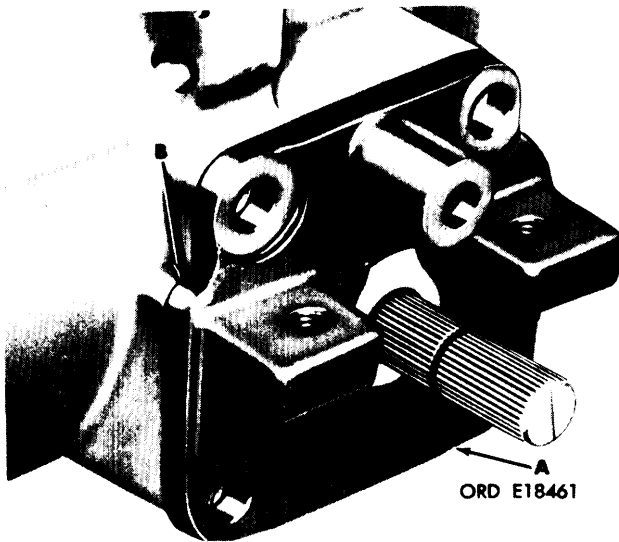

Figure 3-61. Removing operating shaft bearing and associated parts (all pumps except code A).

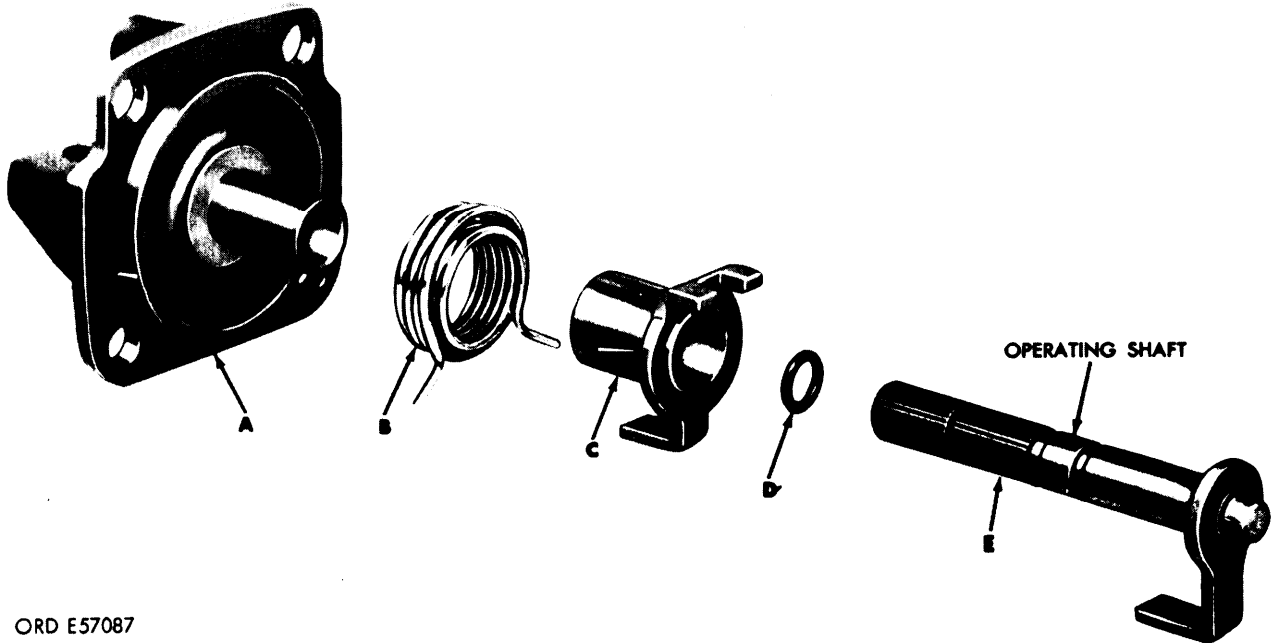

Figure 3-62. Disassembling operating shaft bearing and associated parts (all pumps except code A).

(11) Refer to figure 3-63. Remove fulcrum lever and associated parts as an assembly from governor housing.

NOTE

Paragraph (12), (13), (14) and (15) apply to code A injection pumps only.

(12) Refer to figure 3-64. Remove operating shaft bearing (A) from shaft (C). Remove and discard gasket (B). Remove operating shaft spring (E) and shaft spring plate (D).

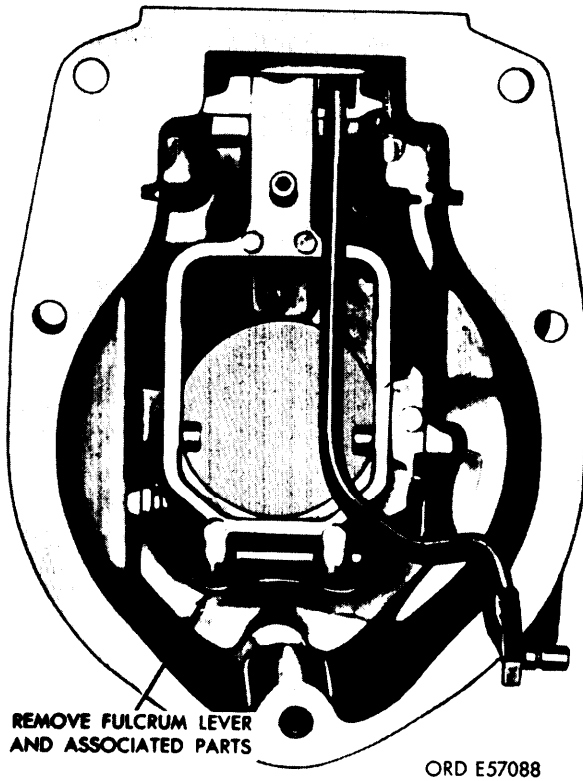
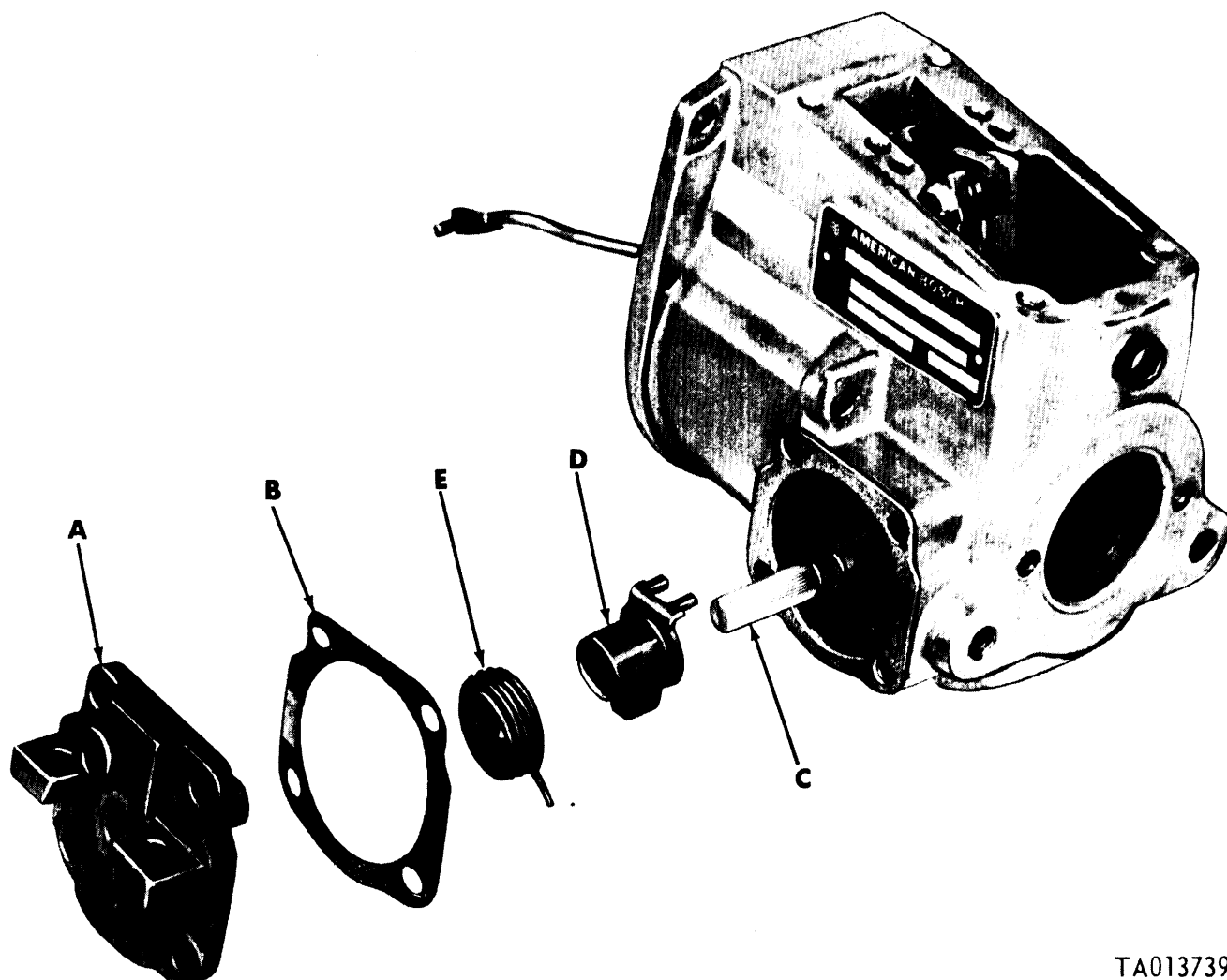

Figure 3-63. Removing fulcrum lever and associated parts (all pumps except code A).



TA013739

Figure 3-64. Removing operating shaft bearing and associated parts (code A pump).

(13) Refer to figure 3-65. Disengage operating shaft assembly (A) from fulcrum lever assembly (B). Remove torque link assembly (C) and operating

shaft as an assembly. Remove fulcrum lever and associated parts.

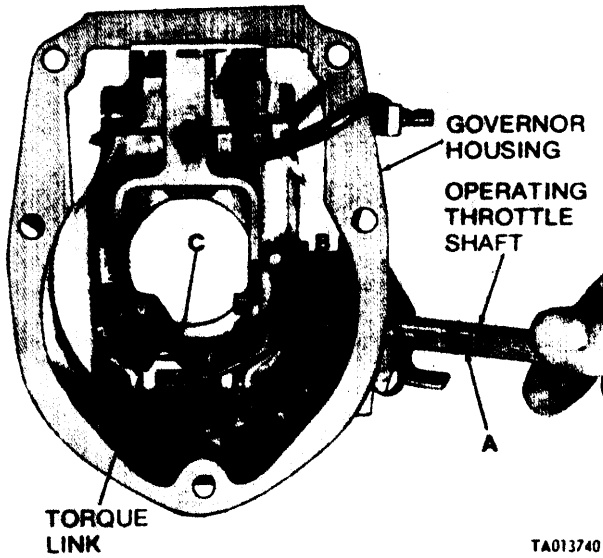

Figure 3-65. Removing or installing torque link assembly in governor housing (code A pumps).

(14) Refer to figure 3-66. Remove two lock pins (A) and two outside washers (B). Separate operating shaft assembly (D) from torque link assembly (C). Remove two inside washers (B) from pins (E). Remove and discard operating shaft packing (F). Remove fuel limiting stop from torque link by removing cotter pin (G), outside flat washer (H), stop (J), inside flat washer (H) and spring washer (K).

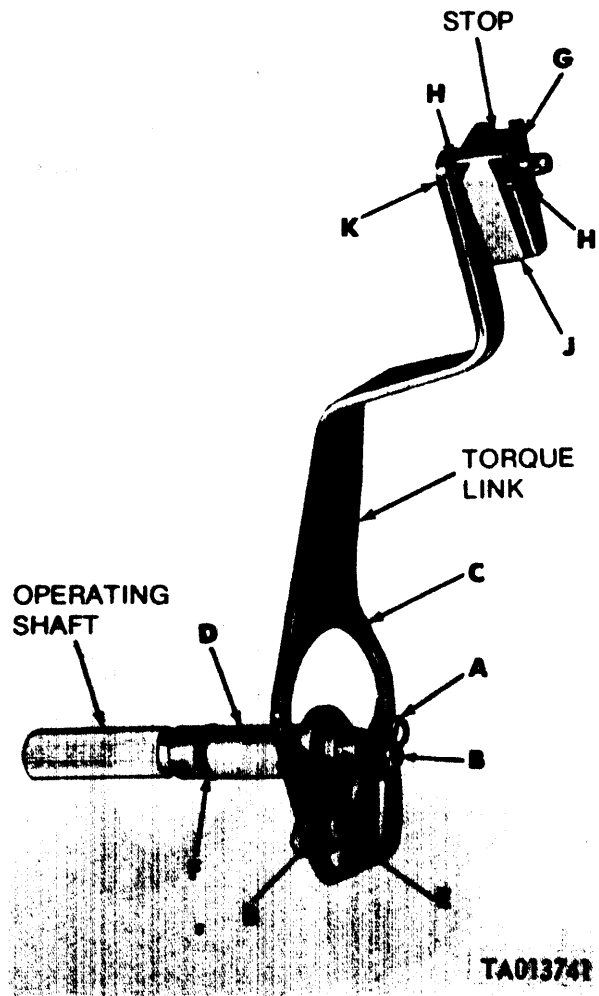

Figure 3-66. Disassembling or assembling of torque link assembly (code A pumps).

NOTE

Refer to paragraph (15) below for disassembly instructions on the fulcrum lever used on code A, B, C, D, E and F pumps. Refer to paragraph (16) below for instructions on the code G pumps.

(15) Refer to figure 3-67. Remove self-locking

nut (A) and fuel control rod (B). Remove flat washer (C) and spring (D). Remove hex nut (E), lock washer (F), control rod pin screw (G), smoke limit cam (H) and spacer (K). (Spacer (K) is used only on code A pumps.) Remove setscrew (J). (Fulcrum lever used in code C and D pumps is not equipped with setscrew (J).)

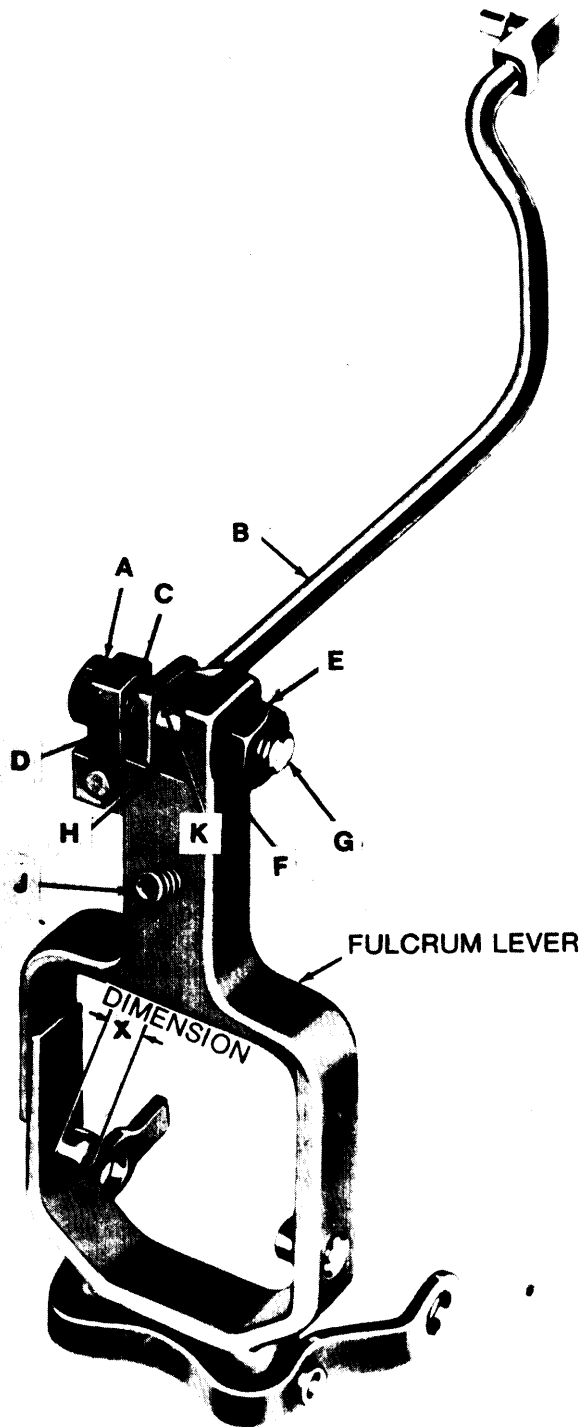

CODE A, B, C, D, E AND F PUMPS

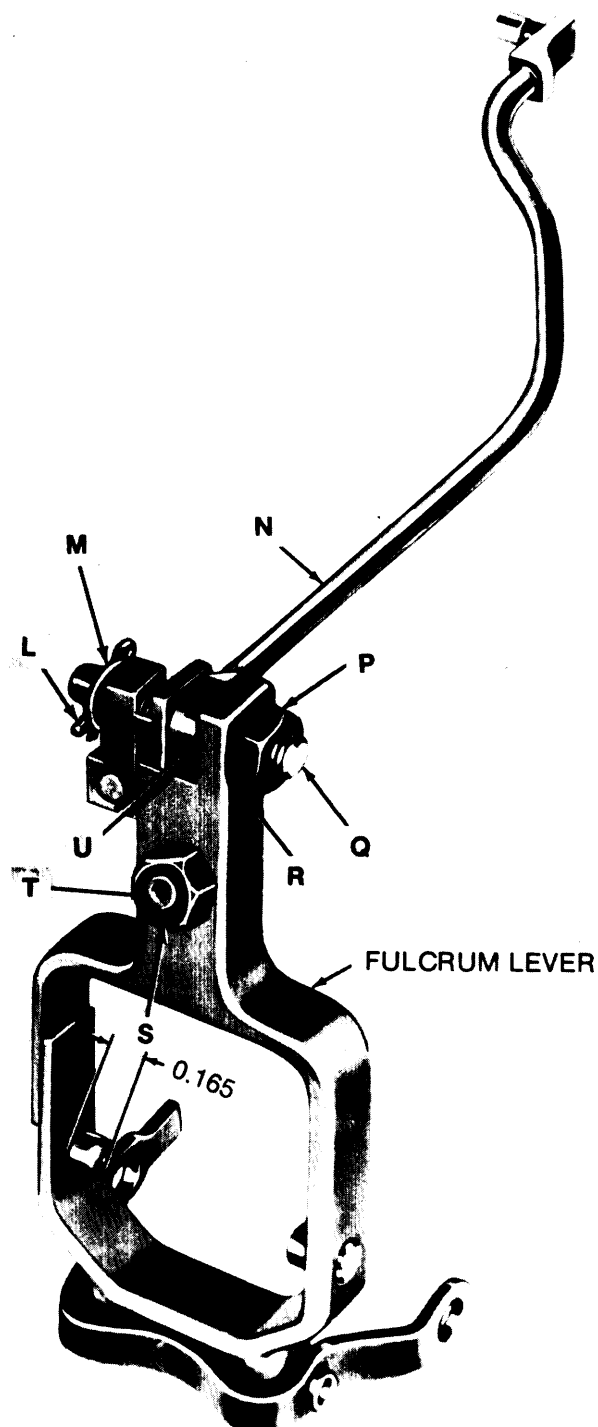

CODE G PUMPS

TA013870

Figure 3-67. Disassembling or assembling fulcrum lever assembly.

(16) Refer to figure 3-67. Remove cotter pin (L), flat washer (M), and fuel control rod (N). Remove hex nut (P), lockwasher (R), control rod pin screw (Q), and smoke limit cam (U). Remove hex nut (S) and setscrew (T).

b. *Inspection and Repair of Governor Assembly.* Inspect and repair the governor assembly as follows:

NOTE

The key letters shown below in parentheses refer to figure 3-70 and 3-71 except where otherwise indicated.

(1) Inspect the governor housing (E) and governor end cap (Q) for cracks and distortion. Replace any part that is cracked or distorted. Examine the gasket surfaces of these parts for scratches, nicks, burs; etc. Repair minor damage with crocus cloth or fine mill file and replace any part that is not repairable.

(2) Check the bracket pivot pin (T) against the limits specified in the repair standards (para 3-60) and replace the pin, as shown in figure 3-68 and 3-69 when it does not meet these requirements.

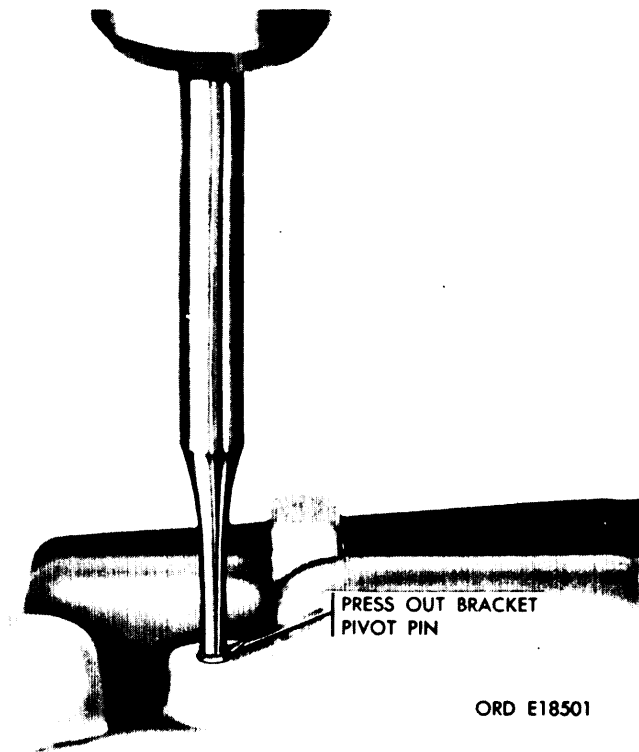

Figure 3-68. Removing bracket pivot pin.

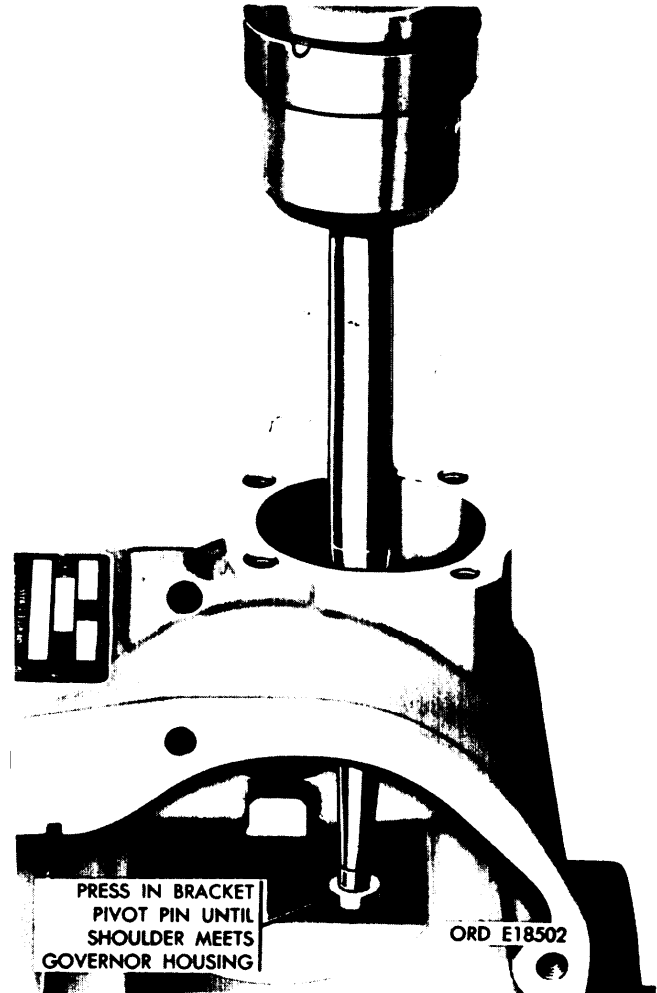
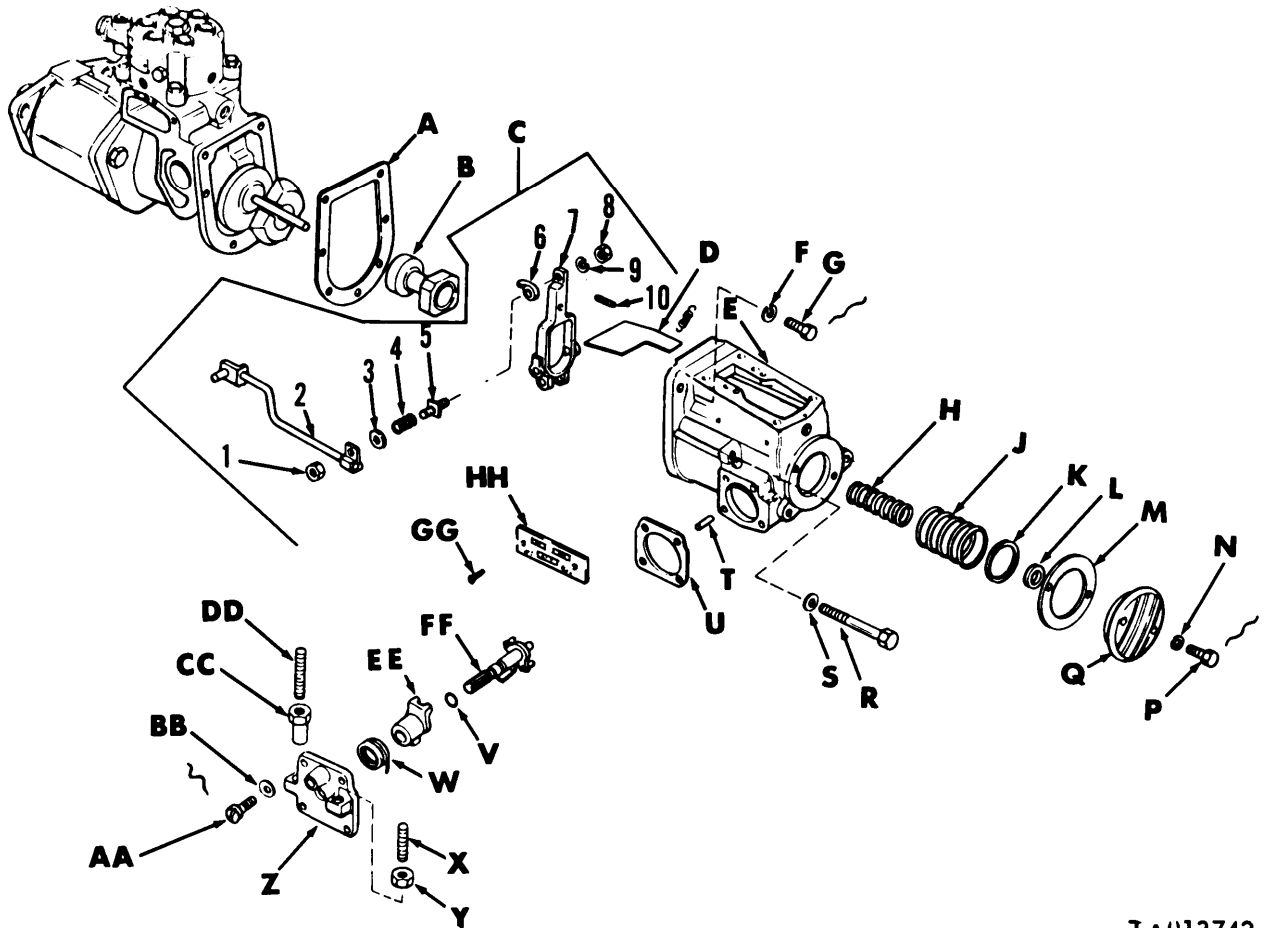

Figure 3-69. Installing bracket pivot pin.

(3) Check the governor inner spring (H) and outer spring (J) against the limits specified in the repair standards (para 3-60), and replace the springs when they do not meet these requirements.

(4) Check the fulcrum lever (C-7) against the limits specified in the repair standards (para 3-60), and replace the lever when it does not meet these requirements. Check for free movement of the bracket on the fulcrum lever. Replace the fulcrum lever when the bracket does not move freely. Check the fulcrum lever pins for looseness. When the pins are loose, replace the fulcrum lever. If the fulcrum lever has a tapped hole (helicoil) for set screw (C-10), inspect for thread damage and replace if necessary.



TA013742

- | | |
|--|--|
| <p>A Governor housing gasket
 B Sliding sleeve
 C Fulcrum lever assembly
 1 ¼-inch self-locking nut
 2 Fuel control rod
 3 ¼-inch flat washer
 4 Control rod spring
 5 Control rod pin screw
 6 Smoke limit cam
 7 Fulcrum lever
 8 ¼-inch plain nut
 9 ¼-inch lockwasher
 10 Adjusting setscrew
 D Oil baffle
 E Governor housing
 F ¼-inch lockwasher
 G ¼x5/8 capscrew
 H Governor inner spring
 J Governor outer spring
 K Outer spring spacer
 L Inner spring spacer</p> | <p>M Governor end cap gasket
 N ¼-inch lockwasher
 P ¼x5/8 capscrew
 Q Governor end cap
 R ¼x3-3/8 capscrew
 S ¼-inch lockwasher
 T Bracket pivot pin
 L Shaft bearing gasket
 V Preformed packing
 W Operating shaft spring
 X High speed adjusting screw
 Y Adjusting screw locknut
 Z Operating shaft bearing
 AA ¼ x ½ machine screw
 BB Gasket
 CC Adjusting screw sleeve nut
 DD Idle speed adjusting screw
 EE Spring plate
 FF Operating lever shaft
 GG Screw
 HH Identification plate</p> |
|--|--|

Figure 3-70. Governor and associated parts (all pumps except code A), exploded view.

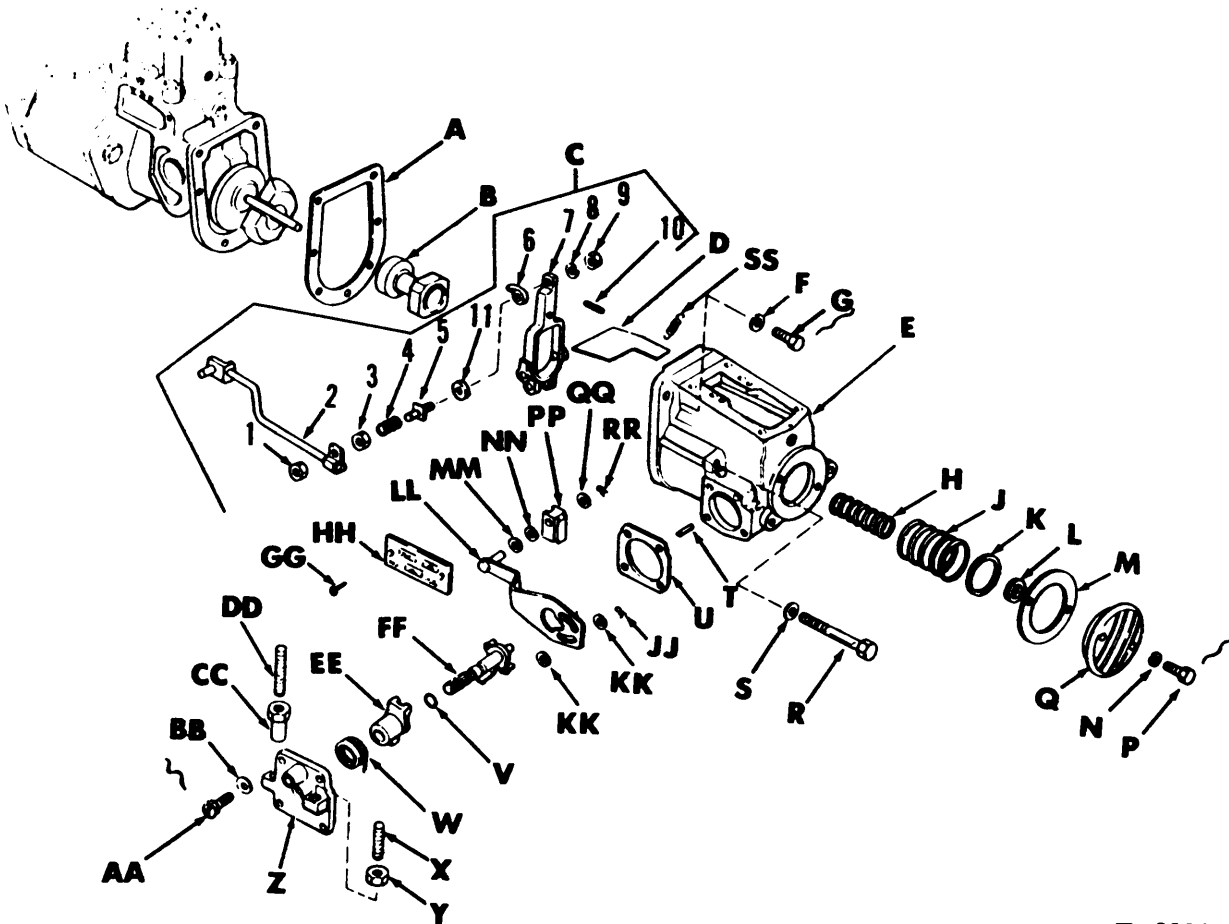

TA013843

- A Governor housing gasket
- B Sliding sleeve
- C Fulcrum lever assembly
 1. ¼-inch self-locking
 2. Fuel control rod
 3. ¼-inch flat washer
 4. Control rod spring
 5. Control rod pin screw
 6. Smoke limit cam
 7. Fulcrum lever
 8. ¼-inch lockwasher
 9. ¼-inch plain nut
 10. Adjusting setscrew (droop)
 11. spacer
- D Oil baffle
- E Governor housing
- F ¼-inch lockwasher
- G ¼ x 5/8 capscrew
- H Governor inner spring
- J Governor outer spring
- K Outer spring spacer
- L Inner spring spacer
- M Governor end cap gasket
- N ¼-inch lockwasher
- P 1/4 x 6/8 capscrew
- Q Governor end cap

- R ¼x3-3/8 capscrew
- S ¼-inch lockwasher
- T Bracket pivot pin
- U Shaft bearing gasket
- V Preformed packing
- W Operating shaft Spring
- X High speed adjusting screw
- Y Adjusting screw lock nut
- Z Operating shaft bearing
- AA ¼x½ machine screw
- BB Gasket
- CC Adjusting screw sleeve nut
- DD Idle speed adjusting screw
- EE Spring plate
- FF Operating lever shaft
- GG Screw
- HH Identification plate
- JJ Clip
- KK Washer, spacer
- LL Torque link
- MM Washer
- NN Washer
- PP Wedge, plate stop
- QQ Washer
- RR Clip
- SS Spring

Figure 3-71. Governor and associated parts (code A pumps), exploded view.

(5) Check sliding sleeve (B) against the limits specified in the repair standards (para 3-60) and replace the sleeve when it does not meet these requirements. Inspect the bearing face of the sleeve to determine the depth of any indentations. When indentations exceed 0.008 -inch, replace the sliding sleeve.

(6) Examine the operating shaft bearing (Z) for burs, nicks, and scratches on the gasket surface and hub diameter. Repair minor burs, nicks, and scratches with a fine mill file or crocus cloth. Replace the operating shaft bearing when any of these conditions are excessive. Check the operating shaft bearing against the limits specified in the repair standards (para 3-60) and replace the bearing when it does not meet these requirements.

(7) Inspect the operating shaft (FF) and shaft spring plate (EE) for wear and replace any worn part or parts. Check parts against the limits specified in the repair standards (para 3-60) and replace parts when they do not meet these requirements. Examine the ends of the operating shaft spring (W) for wear and indentations. When the spring ends are worn or have indentations that exceed 0.004-inch, replace the spring. Generally if the shaft is replaced, the bearing plate is also replaced.

(8) Inspect the smoke limit cam (C-6) for wear patterns and any other visible damage. Replace the part when either condition exists.

(9) Inspect fuel control rod (C-2) and control rod pin screw (C-5) for wear patterns and any other visible damage. Replace parts when either condition exists.

NOTE

Sub-paragraphs (10) and (11) below apply only to code A injection pumps.

(10) Refer to figure 3-66. Inspect the operating shaft torque link pivot pins (E) and shaft assembly (D) for wear and replace shaft assembly if any part is worn. Check shaft against the limits specified in the repair standards (para 3-60).

NOTE

If operating shaft is replaced, replace shaft bearing.

(11) Refer to figure 3-66. Inspect pin slots, and stop pin on torque link (C) for wear, damage and cracks. Replace torque link where showing wear or damage.

c. *Assembly.* Assemble the governor as follows:

NOTE

Refer to figure 3-72 for identification of governor housings. All pumps use a pipe plug in the bottom of the governor housing as shown.

(1) The parts in the universal governor and linkage repair kit 5702685 are listed and illustrated in appendix B. The parts applicable to this governor and linkage must be used in repair of the governor.

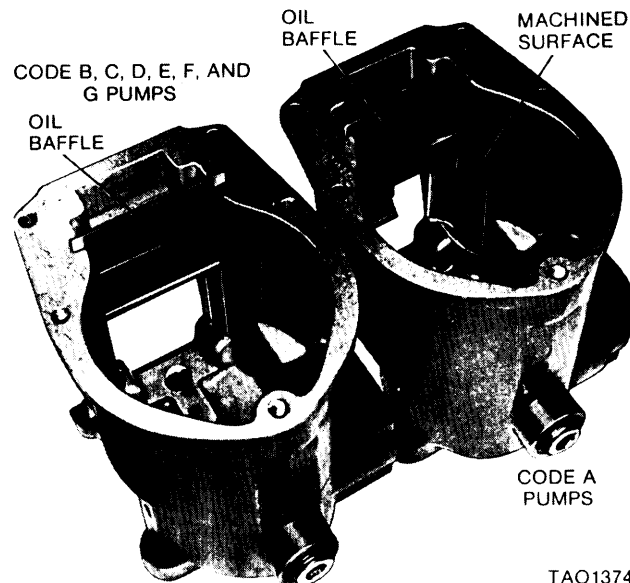

Figure 3-72. Identification of governor housings.

NOTE

Refer to (2) below for assembly instructions on the fulcrum lever used on code A, B, C, D, E, and F series pumps. Refer to (3) below for instructions on code G pumps.

(2) Refer to figure 3-67. Code A pumps must have a fulcrum lever pivot pin dimension (X) of 0.204. Code B, C, D, E, and F pumps must have a fulcrum lever pivot pin dimension (X) of 0.165. Install setscrew (J). (Setscrew (J) is not used on code C and D pumps.) Assemble spacer (K) (spacer (K) is used only on code A pumps) and smoke limit cam (H) on control rod pin screw (G) and install the control rod pin screw on the fulcrum lever. Secure with lock washer (F) and hex nut (E) after setting the smoke cam angle per table in figure 3-73. Use improvised tool (figure 2-1) to set cam angle. Torque tighten hex nut (E) to 50-60 inch-pounds. Install spring (D) and washer (C) on control rod pin screw and install control rod (B). Secure with self-locking nut (A) torqued to 12-14 inch pounds.

(3) Refer to figure 3-67. Code G pumps should have a fulcrum lever pivot pin dimension of 0.165. Install setscrew (T) and hex nut (S). One or two threads of setscrew should extend beyond hex nut for preliminary adjustments. Assemble smoke limit cam (U) on control rod pin screw (Q) and install the control rod pin screw on the fulcrum lever. Secure with lock washer (R) and hex nut (P) after setting the smoke cam angle per table in figure 3-73. Use improvised tool (figure 2-1) to set cam angle. Torque tighten hex nut to 50-60 inch-pounds. Install fuel control rod (N), flat washer (M) and cotter pin (L).

Install cotter pin from bottom and spread prongs tightly around the rod pin screw.

NOTE

After assembly, place fulcrum lever in vertical position. Raise fuel control rod to a horizontal position. When free, fuel control rod should drop slowly of its own weight.

NOTE

Paragraphs (4), (5) and (6) do not apply to code A injection pumps.

(4) Refer to figure 3-74 and install fulcrum lever assembly in governor housing. Fulcrum lever pivot pins must have a dimension (X) (fig. 3-67) of 0.165.

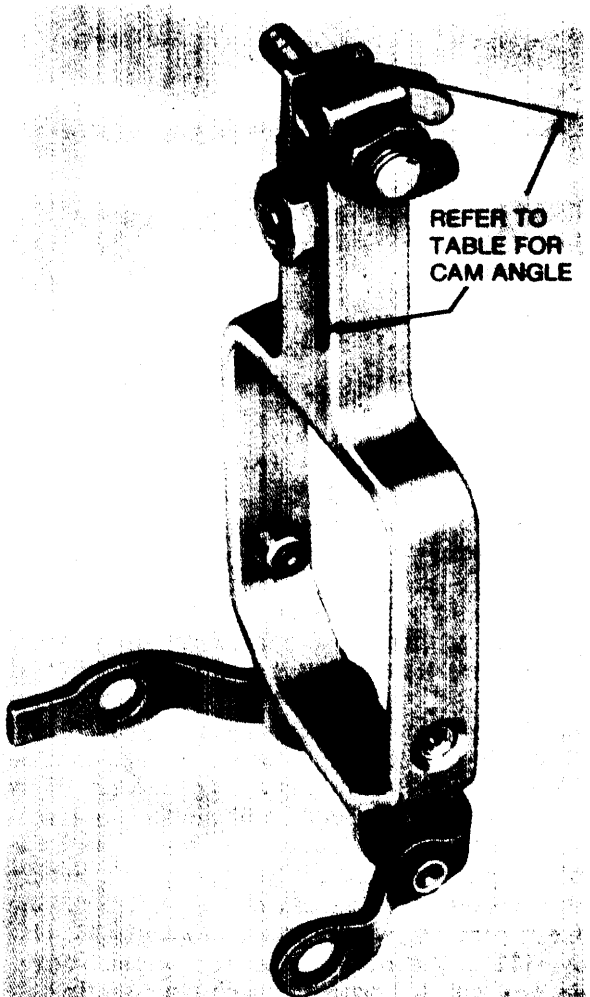

ANGULAR POSITION OF SMOKE CAM

Injection Pump Code	Engine Model	Cam Angle
A	LDS465-2	70 Deg.
B	LDS-465-1A	100 Deg.
C	LD-465-1	75 Deg.
D	LD-465-1C	75 Deg.
E	LDT-465-1C	40 Deg.
F	LDS-465-1	100 Deg.
G	EDS-427-2	65 Deg.

TA91387

Figure 3-73. Adjusting smoke limit cam angle.

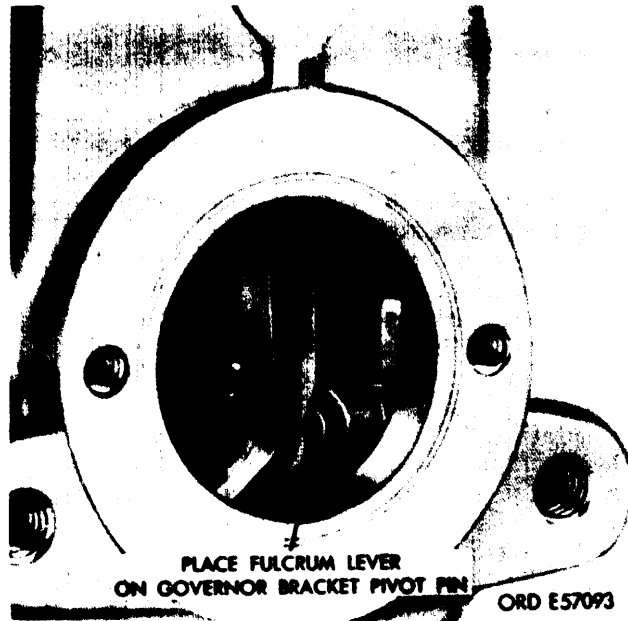
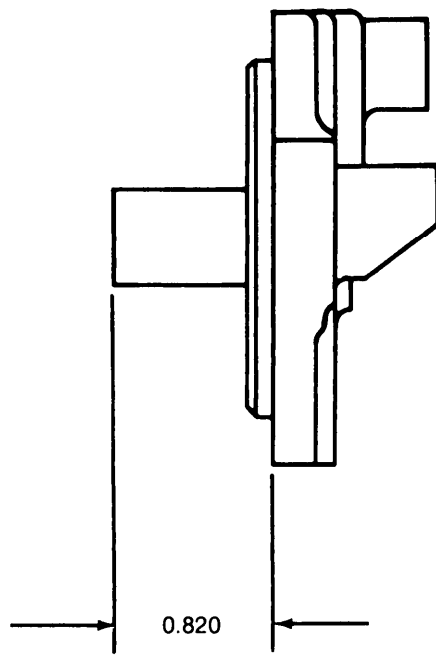
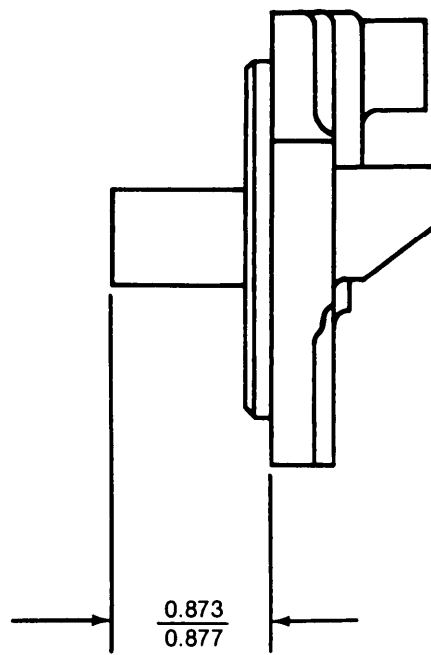

Figure 3-74. Installing fulcrum lever and associated sin governor housing.



CODE A



OTHERS

OPERATING SHAFT BEARING

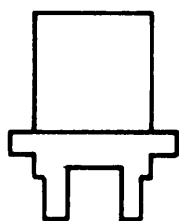

CODE A INJECTION PUMPS

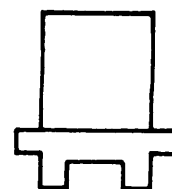

CODE B, C, D, E, F AND G INJECTION PUMPS

OPERATING SHAFT SPRING PLATE

TA013745

Figure 3-75. Identification of operating shaft bearings and spring plates.

NOTE

Refer to figure 3-75 for selection of proper operating shaft bearing and operating shaft spring plate for each pump. All operating shafts should have a retaining ring groove.

(5) Refer to figure 3-76. Install operating shaft packing (D, fig. 3-62) on operating shaft. Install the operating shaft spring (A) on the shaft spring plate (B) with the spring ends gripping the tang on the shaft spring plate. Install the shaft spring plate and operating shaft spring on the operating shaft bearing. Install operating shaft (C) so its arm is between spring ends.

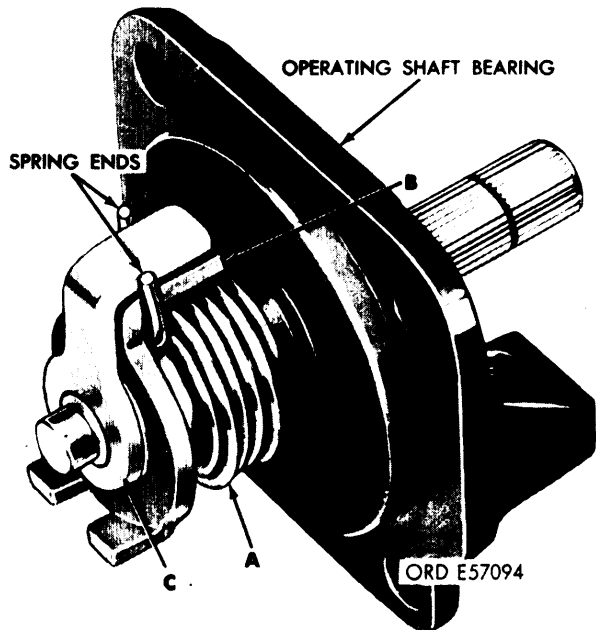

Figure 3-76. Assembling operating shaft bearing and associated parts.

(6) Refer to figure 3-77. Install operating shaft bearing gasket (A) and operating shaft bearing and associated parts (B) on governor housing. Spring plate prongs must engage fulcrum lever finger. Groove in end of operating shaft must be vertical when installed, see figure 3-61.

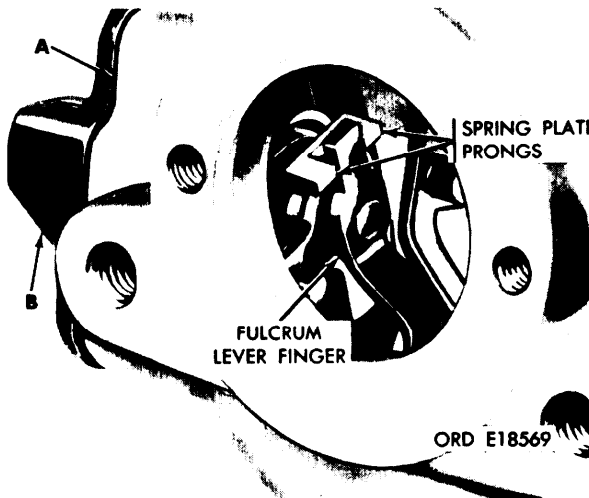

Figure 3-77. Installing operating shaft bearing and associated parts in governor housing.

NOTE

Sub-paragraphs (7) through (12) below apply only to code A pumps.

(7) Refer to figure 3-74. Install fulcrum lever assembly in governor housing. Fulcrum lever pivot pin must have a dimension (X) (fig. 3-67) of 0.204.

(8) Refer to figure 3-66 and install two inside washers (B) on pins (E). Assemble the torque link (C) to the operating shaft (D). Secure with two outside washers (B) and lock pins (A). Torque link should operate freely on pins. Assemble spring washer (K) inside flat washer (H) stop (J) in position shown out side flat washer (H) on torque link and retain with cotter pin (G). Install new packing (F) on operating shaft. Install operating shaft and torque link assembly in governor housing per figure 3-65.

NOTE

The torque link stop is furnished with the density compensator. The stop furnished with the new compensator should be installed with the compensator.

(9) Refer to figure 3-78. Engage operating shaft assembly pin (A) in fulcrum lever (B) with torque link positioned as shown. Rotate torque link upward.

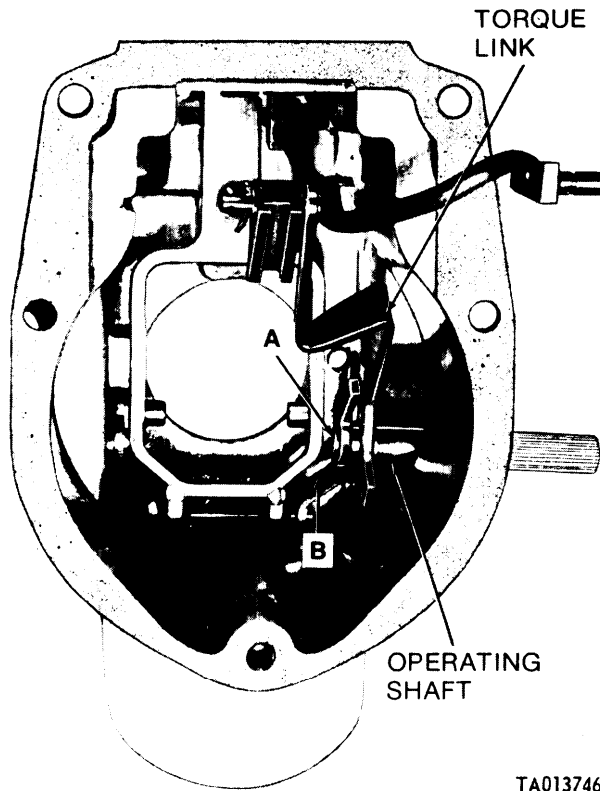

Figure 3-78. Engaging operating shaft bearing to fulcrum lever (code A pumps).

NOTE

Refer to figure 3-75 for selection of operating shaft bearing and operating shaft spring plate.

(10) Refer to figure 3-79. Install operating shaft spring (A) on operating shaft spring plate (B). Refer to figure 3-80. Install operating shaft spring and plate (A) on operating shaft (B). Make sure the spring engages the tang on the operating shaft.

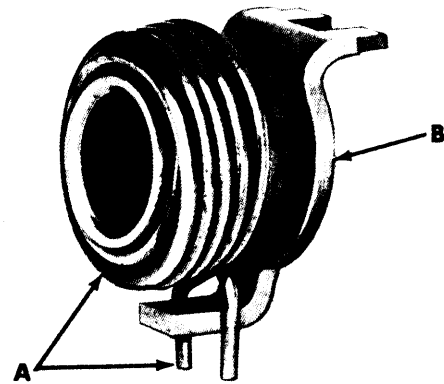

Figure 3-79. Assembling operating shaft spring and plate (code A pumps).

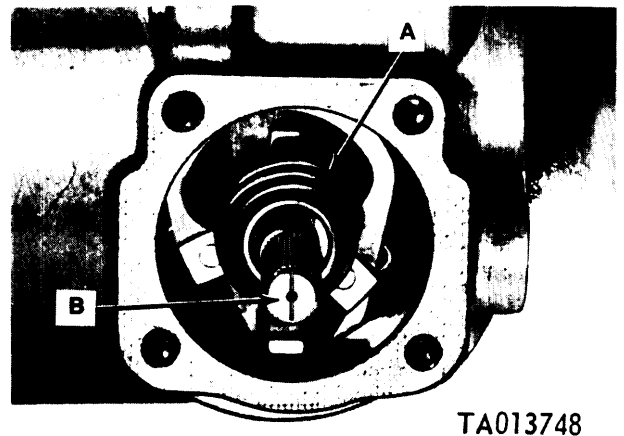

Figure 3-80. Installing operating shaft spring and plate on operating shaft (code A pumps).

(11) Refer to figure 3-77 to insure that the spring plate prongs have engaged the fulcrum lever assembly finger.

(12) Refer to figure 3-61. Install gasket (B) and operating shaft bearing (A).

(13) Refer to figure 3-81. Install four bearing mounting machine screws (A) and four copper gaskets (B). Torque tighten screws 50-60 inch-pounds and secure with locking wire.

NOTE

Locking wire must be installed as shown to avoid interference with movement of stop lever.

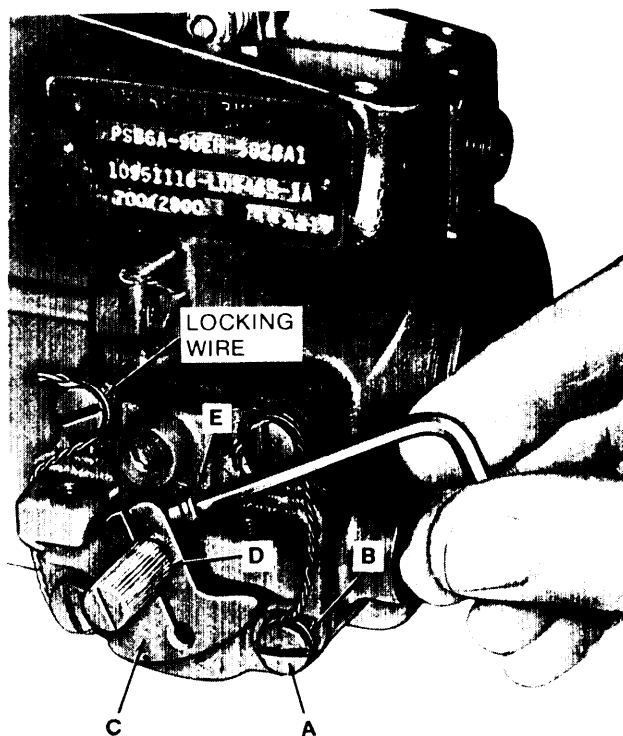

TA013749

Figure 3-81. Installing stop lever and associated parts.

NOTE

Sub -paragraphs (14) through (18) below do not apply to code A pumps.

(14) Refer to figure 3-81. Install lever (C) with slot alined with groove or scribe mark in end of operating shaft. Install retaining ring (D). Hold stop

lever against retaining ring and install clamping screw (E), and check clearance to obtain a tolerance of 0.002 to 0.004 -inch between stop lever and bearing housing. If clearance is not within these limits, replace operating shaft bearing housing. Torque tighten clamping screw to 50-60 inch-pounds.

(15) Refer to figure 3-59 and install the operating lever on operating shaft, and secure with clamping screw (G), lockwasher (F) and hex nut (E). Torque tighten nut to 70-75 inch-pounds. Position lever as shown with split in lever alined with scribe mark or groove on shaft as shown in figure 3-82.

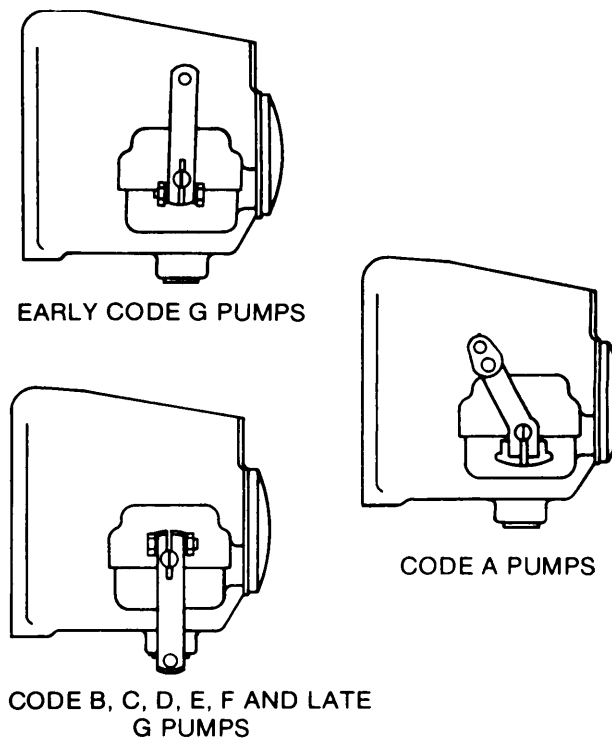

TA013750

Figure 3-82. Positioning operating levers.

(16) Refer to figure 3-83. Install idle adjusting screw (A) and lock sleeve nut (B) with approximately .5/32-inch of exposed thread at the bottom. Finger tighten locknut. Install high speed adjustment screw (C) with approximately 5/32-inch exposed thread at the bottom. Install hex nut (D) and tighten finger tight. Final adjustment of idle and high speed adjustment screws is made during calibration of the pump.

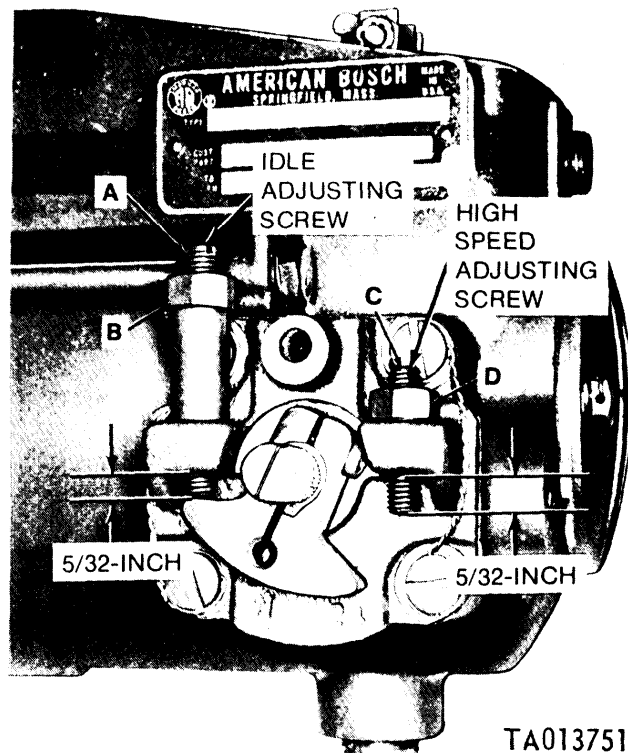

TA013751

Figure 3-83. Installing high speed and idle adjustment screws.

(17) Refer to figure 3-59 and install dust cover (D), lockwasher (C) and machine bolt (B). Torque tighten dust cover bolt to 50-60 inch-pounds. Do not install lead seal safety wire at this time.

(18) Refer to figure 3-84. Insert a feeler gage (A) to obtain a clearance of 0.002 to 0.004 inch between the operating lever and dust cover. Loosen clamping screw (B), lockwasher (C), and nut (D). Move lever as necessary to obtain this clearance. Torque tighten nut to 70-75 inch-pounds.

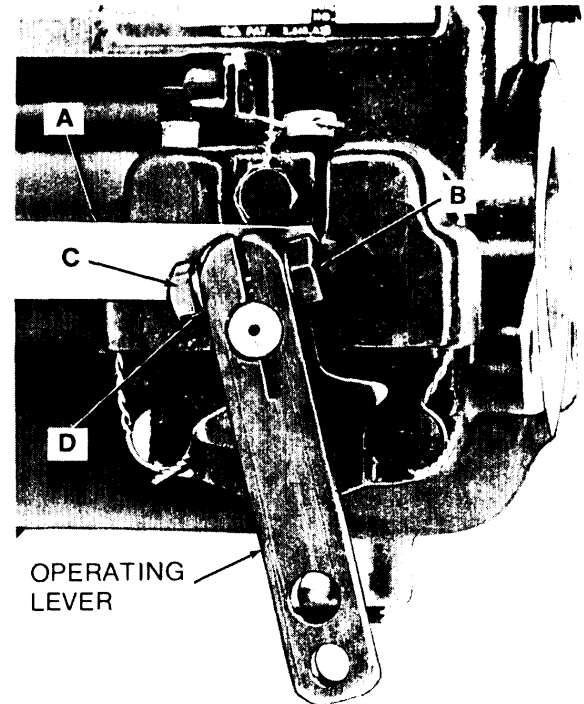

TA013752

Figure 3-84. Checking operating lever clearance using a feeler gage

NOTE

Sub-paragraph (19) below applies to code A pumps only.

(19) Refer to (16) above and figure 3-83 and install idle and high speed adjusting screws. Refer to figure 3-85. The operating lever and stop lever is one piece on this pump. Install screw (A), lockwasher (B) and nut (C). Install operating lever assembly in up position on operating shaft (D) with the split in lever aligned with scribe mark on end of operating shaft

(D). Insert a feeler gage (E) to obtain a clearance of 0.002 to 0.004-inch between the operating lever and operating shaft bearing; move lever as necessary to obtain this clearance, Torque tighten nut (C) to 70-75 inch-pounds. Install dust cover, lockwasher and machine bolt; refer to ((17) above). Check operating lever clearance at dust cover ((18) above).

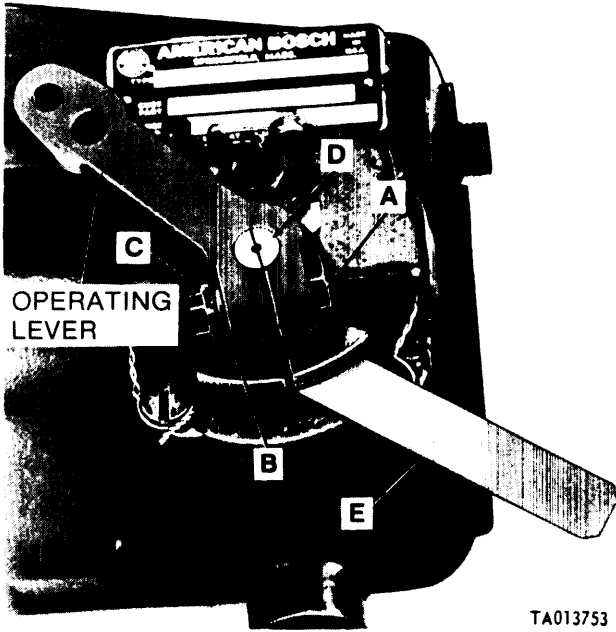

Figure 3-85. Installing operating lever using a feeler gage (code A pumps).

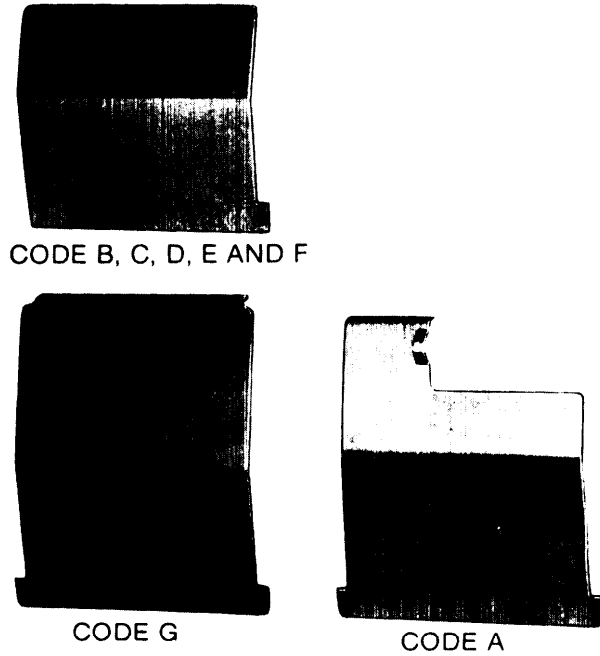
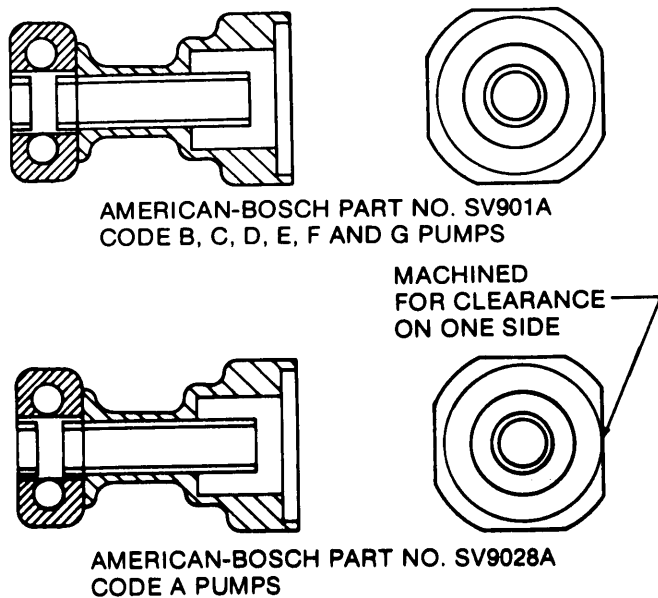

Figure 3-86. Identification of oil baffles.



TA013755

Figure 3-87. Identification of governor sliding sleeve assemblies.

NOTE

Refer to figure 3-86 and 3-87 for selection of sliding sleeve and oil baffles.

(20) Refer to figure 3-88. Install oil baffle (A) and sliding sleeve (B) on pins in fulcrum lever.

NOTE

The governor springs, spacers, and end cap will be installed after governor is installed on fuel injection pump housing.

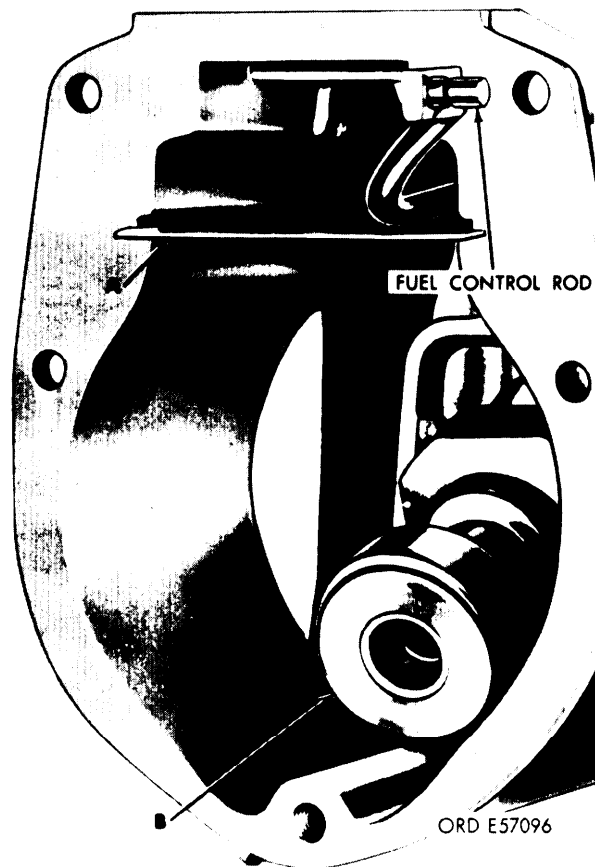
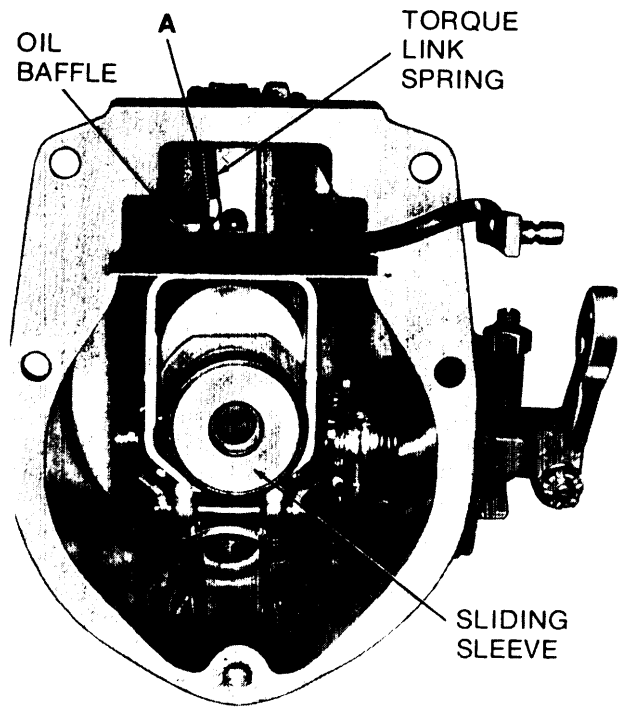

Figure 3-88. Installing oil baffle and sliding sleeve.

NOTE

Sub-paragraph (21) below applies to code A pumps only.

(21) Refer to figure 3-89 and install torque link spring (A) from torque link pin to oil baffle.



TA013756

Figure 3-89. Installing oil baffle, sliding sleeve and torque link spring (code A pumps).

3-26. Repair of Governor Weight and Spider Assembly. a. Disassembly. Disassemble the governor friction drive as follows:

(1) Before any disassembly of the friction drive assembly, check clearance between the governor weight pin and weight pin bushing using a dial indicator. Maximum allowable clearance is 0.003 - inch with weights in their outermost position. If clearance is greater than 0.003-inch, replace the complete governor weight and spider assembly.

(2) Refer to figure 3-90. Place friction drive spider (A) on a piece of 3/8 x 3/4 steel stock held in vise. Remove spring disk adjusting nut using socket wrench (B).

NOTE

Early model friction drive spider assemblies were assembled with a retainer. If retainer (G, fig. 3-91) is removed at disassembly it must be reinstalled at assembly. Later model friction drive spider assemblies did not utilize this part and reference to it can be disregarded. Early code G pumps have a special nut which requires use of spanner wrench 5120-793-5046 for removal.

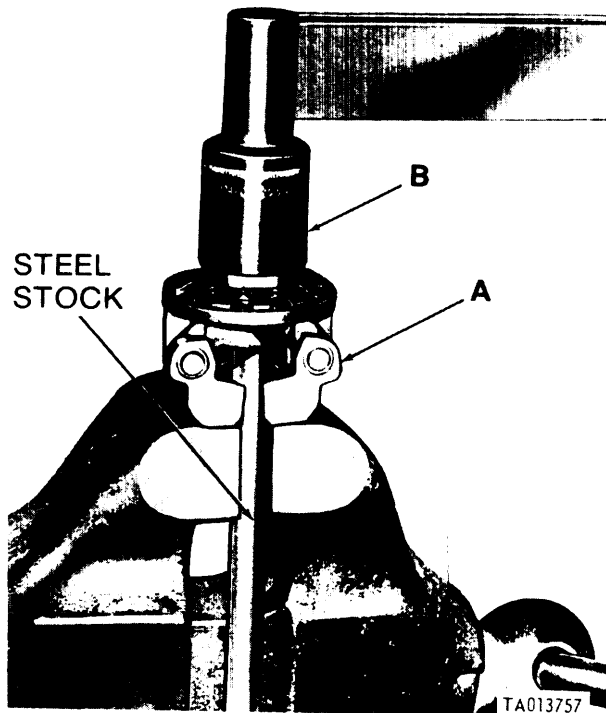

Figure 3-90. Removing or installing spring disk adjusting nut.

(3) Refer to figure 3-91. Remove outer spring disk (B) spring disk spacer (C) inner spring disk (D) and spring disk spacer (E) and retainer if used, from friction drive spider.

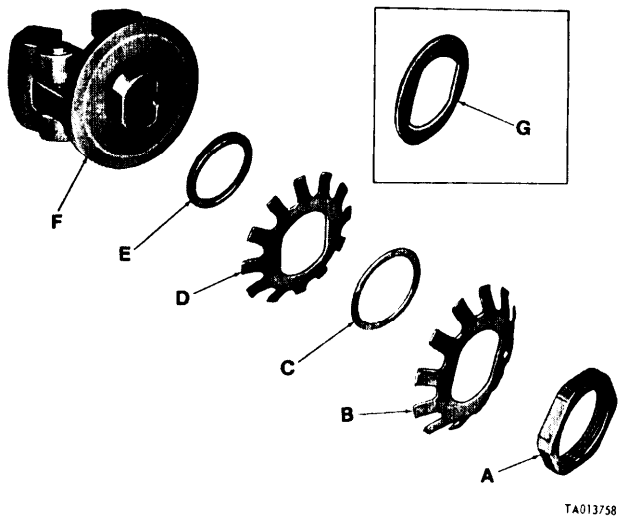

Figure 3-91. Disassembling or assembling friction drive spider and associated parts.

b. Inspection of Governor Weight and Spider Assembly.

(1) Inspect the fingers on the spring disks (B)

and D, fig. 3-91) and the mating surface on the friction drive spider for evidence of wear or damage.

(2) Carefully inspect the mating surface of the drive hub (fig. 3-92) and spider for evidence of wear or damage.

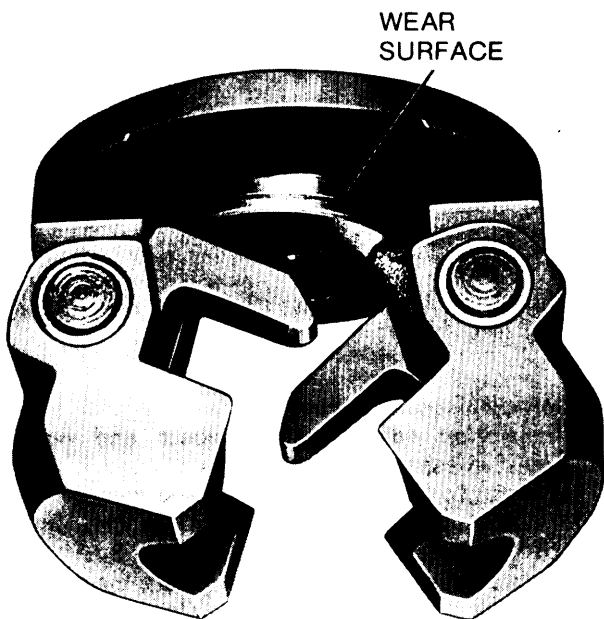

TA013759

Figure 3-92. Inspecting friction drive spider wear surface.

(3) If damage or wear is evident on any part, replace the complete assembly. Retain the weight and spider assembly for possible repair.

c. *Assembly.* Assemble the governor weight and spider assembly as follows:

(1) Refer to figure 3-91. Install retainer (if used), 0.035-inch spring disk spacer (E), inner spring disk (D), 0.035-inch spring disk spacer (C), outer spring disk (B) and nut (A).

NOTE

The outer spring disk contains an identification hole to distinguish it from the inner disk.

(2) Refer to figure 3-90. Position governor weight assembly in vise using 3/8 x 3/4-inch steel bar stock as shown. Tighten hub nut to 80-85 foot-pounds. Remove friction drive spider and governor weight assembly and bar stock from vise.

(3) Refer to figure 3-93. Install friction drive spider and governor weight assembly in vise equipped with soft metal jaws as shown. Lubricate the spring disk bearing surface with engine oil and take a running torque reading. Torque reading should be between 48 and 72 inch-pounds. If the torque reading falls below these limits, install a thinner spring disk spacer (E, fig. 3-91). If the torque reading exceeds these limits, replace the governor weight and spider assembly.

(4) Refer to figure 3-94. Using a center punch, stake spring disk adjusting nut at two points indicated to prevent nut from loosening.

(5) Remove friction drive spider and governor assembly from vise.

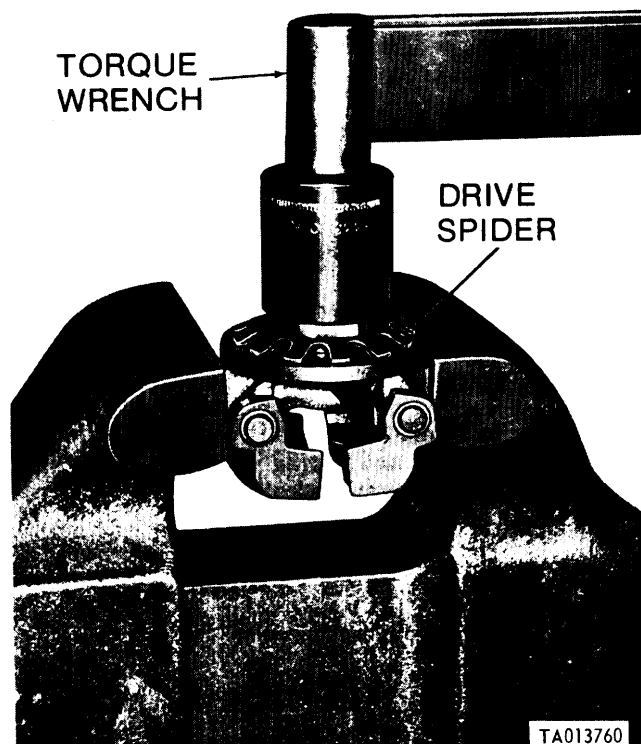

Figure 3-93. Checking friction drive spider slippage.

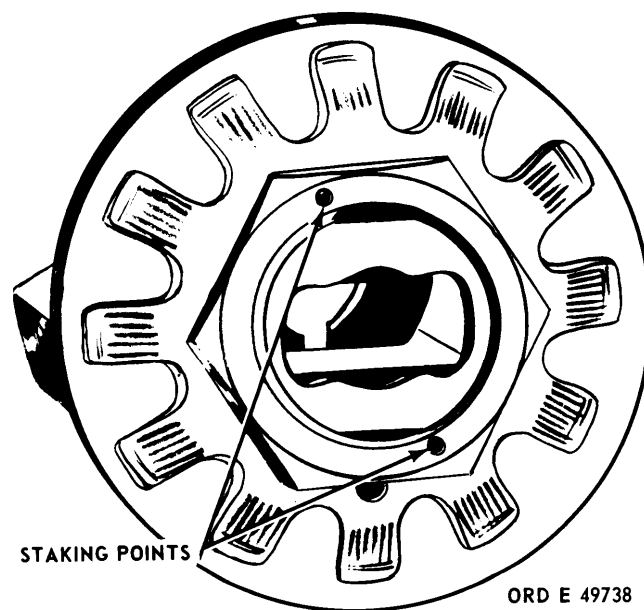
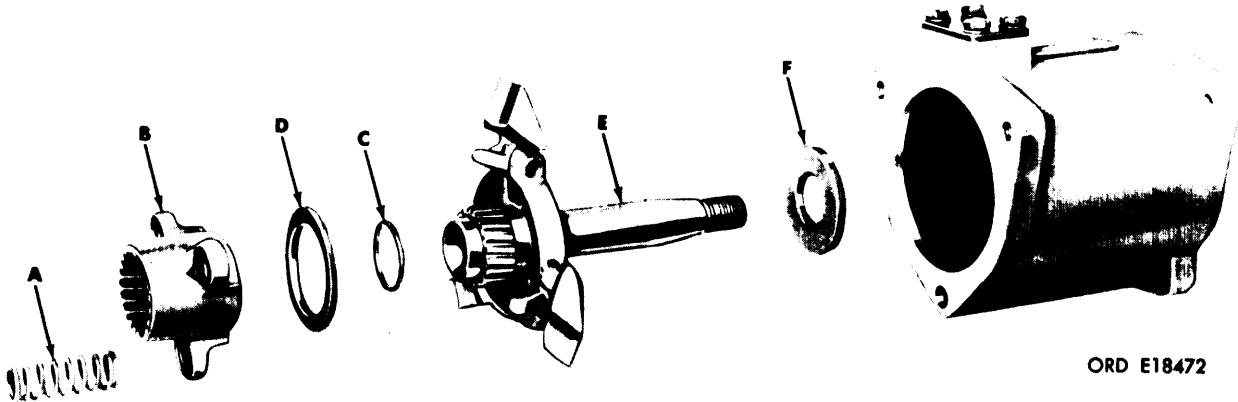

Figure 3-94. Staking spring disk adjusting nut.

3-27. Repair of Timing Device Assembly. a. Disassembly.

(1) Refer to figure 3-95. Remove the three

timing device springs (A). Remove sliding gear (B), end play spacer (C), sliding gear spacer (D) and spider thrust plate (F).



ORD E18472

Figure 3-95. Removing sliding gear, spider assembly and associated parts.

(2) Refer to figure 3-96. Remove four capscrews (A), lockwashers (B), and timing cover (C). Remove and discard timing cover gasket (D).

b. Inspection and Repair. Inspect and repair timing device assembly as follows:

(1) Refer to figure 3-97. Check the components of the timing device assembly against the limits specified in the repair standards (para 3-63) and replace the components when they do not meet these requirements.

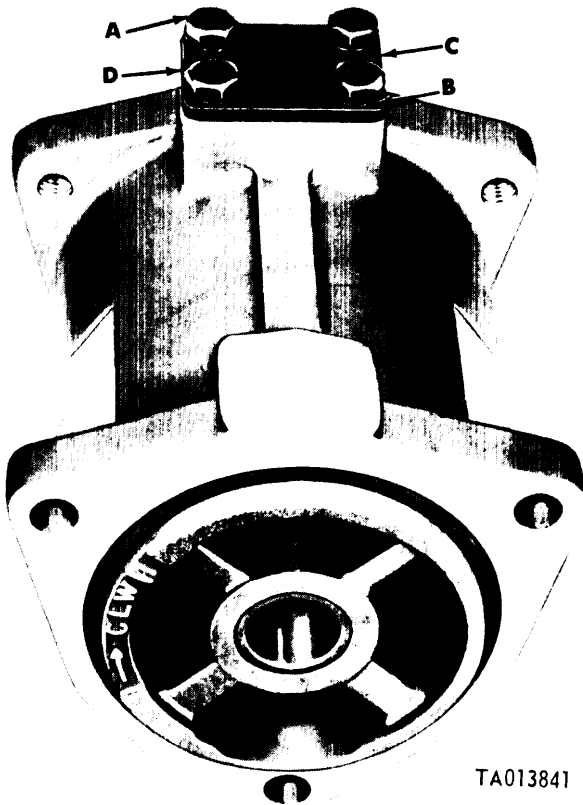

TA013841

Figure 3-96. Removing or installing timing cover.

KEY to fig. 3-97

- A Preformed packing
- B 1/4-inch lockwasher
- C 1/4x5/8 machine screw
- D Timing cover
- E Timing cover gasket
- F Thrust plate
- G Weight and spider assembly
- H Housing assembly
 - 1 Bushing type bearing
 - 2 Housing
- J End play spacer
- K Sliding gear spacer
- L Sliding gear
- M Timing device spring
- N Camshaft nut
- P Timing device
- Q Camshaft nut setscrew

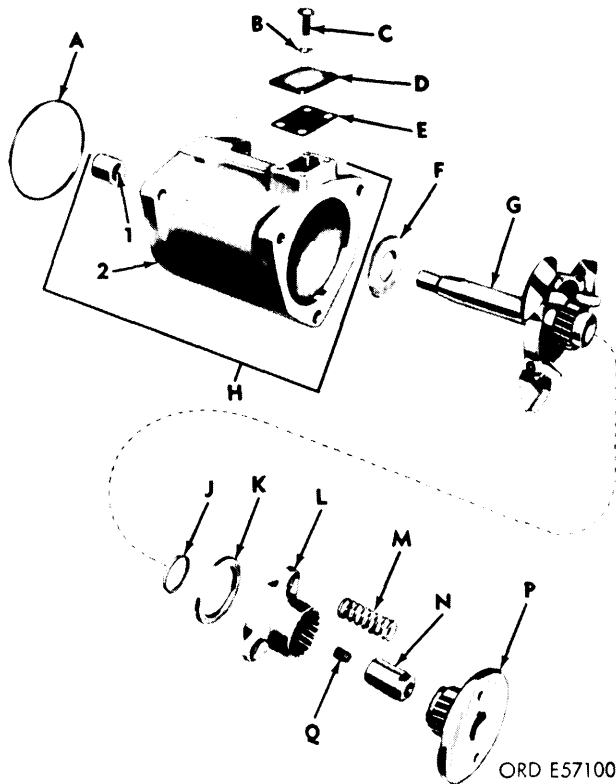

Figure 3-97. Timing device assembly, exploded view.

(2) Inspect the timing device housing (H) for cracks, nicks, burs, and damage to mating surfaces. Replace the housing when cracked. Minor nicks or burs may be cleaned up with crocus cloth.

(3) Inspect the splines of the weight and spider assembly (G), sliding gear (L), and timing device hub (P) for damage, wear, and fit on mating surfaces. Remove minor burs and scratches from splines with crocus cloth. Replace all parts having splines which are damaged or do not fit properly with mating surfaces.

(4) Refer to figure 3-98. Inspect the pins that secure the weights to the spider. Weight and spiders assembled with pin (A) should be discarded and replaced. Weight and spiders assembled with pin (B) can be reused if the pins have no end play and are tight.

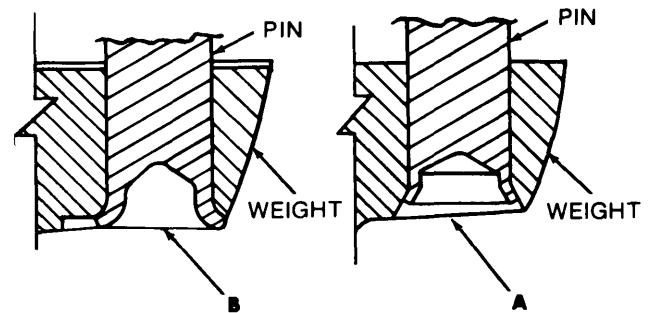

Figure 3-98. Comparison of timing device weight pins.

(5) Examine the weight on the spider assembly (G) for freedom of movement. Replace the weight and spider assembly when the weights do not move freely.

c. Assembly. Assemble the timing device assembly as follows:

(1) The parts for the universal timing device repair kit are listed in Appendix B. When any part in the repair kit—5702661 except hardware items, must be replaced, replace all parts applicable to the timing device assembly.

(2) Refer to figure 3-97. Do not install timing cover at this time. The timing device assembly parts will be installed during assembly of pump.

3-28. Repair of Hydraulic Head Assembly.

NOTE

Except for the upper and lower head preformed packings, component parts of the hydraulic heads are not spare parts. If any part shows evidence of wear or other damage replace the complete head assembly. Refer to figure 3-99. Hydraulic head assemblies identified by American Bosch part number HD9070A (FSN 2910-084-0259), used on some code F pumps, are prone to cracking between the delivery valve screw and cylinder No. 3 port. These heads must be replaced upon disassembly of injection pump.

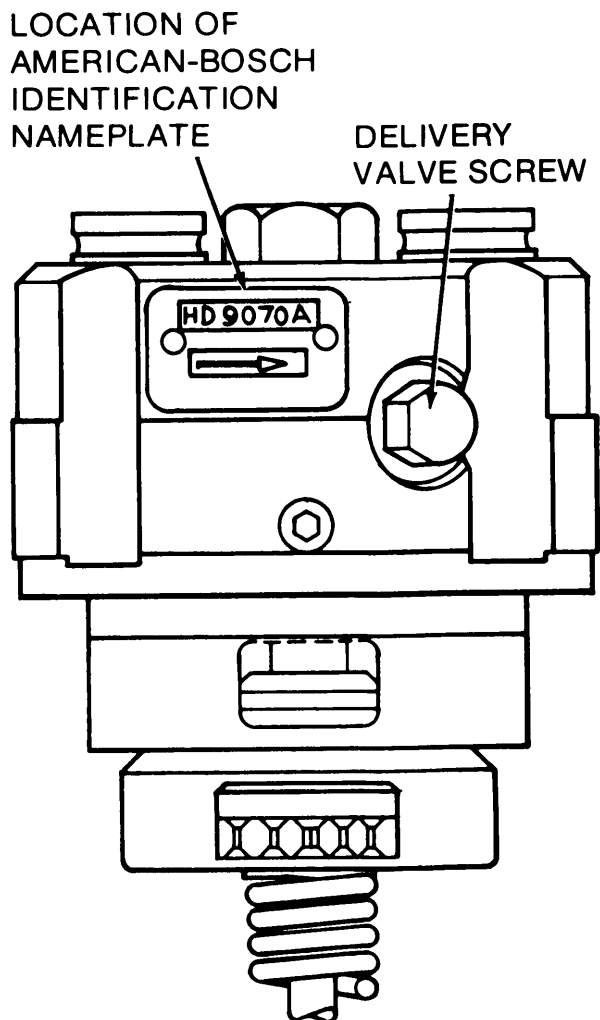

TA013762

Figure 3-99. Identification of hydraulic head assembly HD9070A (2910-084-0259).

a. *Disassembly.* Refer to figure 3-100. Remove and discard hydraulic head lower preformed packing (A) and upper preformed packing (B). Do not remove fuel inlet fitting.

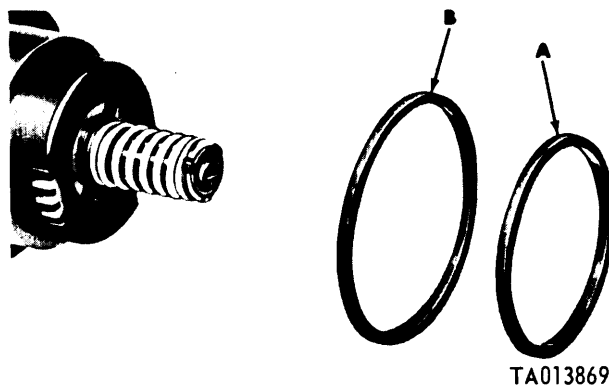
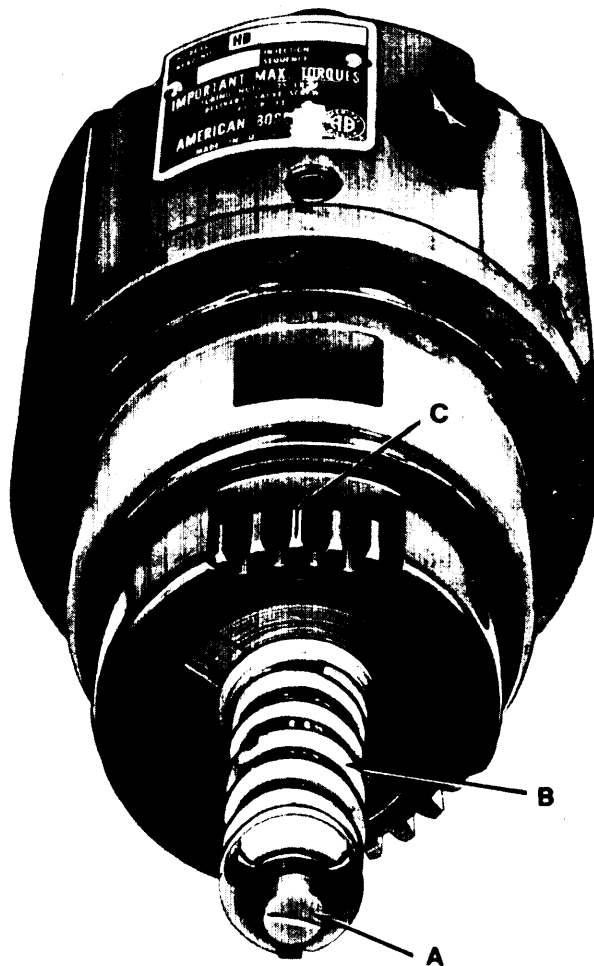

Figure 3-100. Removing or installing hydraulic head packings.
b. *Inspection.* Inspect the hydraulic head assembly as follows:

(1) Refer to figure 3-101. Examine plunger button (A) and spring (B) for evidence of wear. Check spring coils for breaks, cracks or distortion. Check gear teeth (C) for wear patterns and chipped or broken teeth.



TA013763

Figure 3-101. Inspection of hydraulic head components.

(2) Manually work plunger up and down, rotating slowly to make sure plunger is free in bore. There cannot be any binding.

(3) Refer to figure 3-102. Using suitable feeler gages check plunger sleeve slot width (A). Replace head if slot width is greater than 0.1007 in. Sleeve should fall of its own weight on plunger. If it does not, lubricate with diesel fuel and recheck. If sleeve does not free up, discard head assembly.

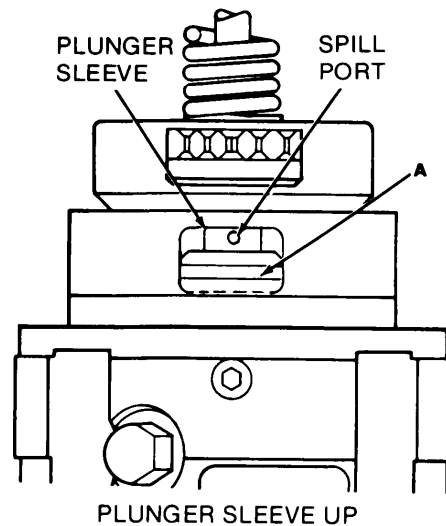
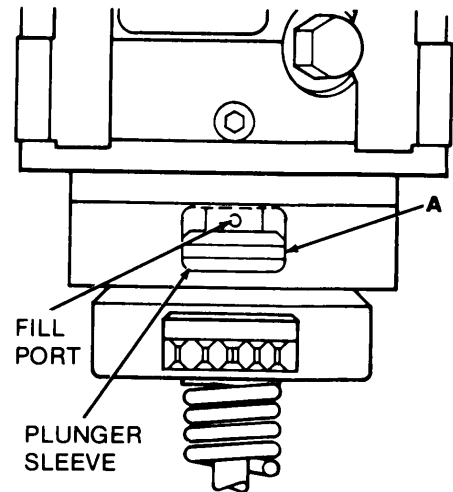

TA013764

Figure 3-102. Inspection of spill ports and plunger sleeve.

(4) With plunger stationary, check backlash of drive gear. Backlash must not exceed 0.025-inch.

(5) Refer to figure 3-102. Position plunger sleeve to expose plunger spill and fill ports. Using a magnifying glass inspect the spill port and plunger for evidence of erosion, wear patterns, nicks, burrs or scratches. If erosion is evident it will appear as nibbling around around the fill and spill ports. If any damage is evident, it is necessary to replace the complete head assembly.

c. Assembly. Refer to figure 3-100. Lubricate and install new hydraulic head upper and lower preformed packings (A) and (B).

3-29. Repair of Tappet Assembly. *a. Disassembly.* Refer to figure 3-103. Remove tappet roller pin (C) and tappet roller assembly (A) from tappet guide (B).

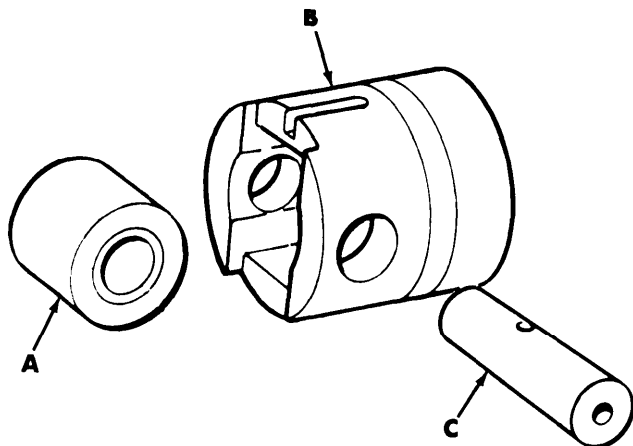

TA013765

Figure 3-103. Disassembling or assembling tappet assembly.

b. Inspection. Inspect the tappet assembly as follows:

(1) Inspect the tappet guide (B) for evidence of wear patterns.

(2) Check the inside and outside diameter of tappet roller assembly (A) and outside diameter of tappet roller pin (C), and the plunger outer spring (T, fig. 3-109) against the limits specified in the repair standards (para 3-60 and 3-61).

(3) Replace the tappet assembly or spring when they do not meet these requirements.

c. Assembly. Refer to figure 3-103 and reverse the sequence of instructions to assemble the tappet assembly.

3-30. Repair of Quill Shaft Assembly.

NOTE

Components of the quill shaft assembly are not spare parts; do not disassemble.

a. Refer to figure 3-104. Check end play clearance between quill shaft gear and shaft spacer. Clearance shaft spacer. Clearance should be 0.001 to 0.006 inches. Inspect gears for chipped, cracked or broken gear teeth.

b. Inspect tapped hole for stripped or damaged threads. Repair threads with suitable tap if possible.

c. If threads are stripped, end play is excessive, or gears are damaged, replace complete assembly.

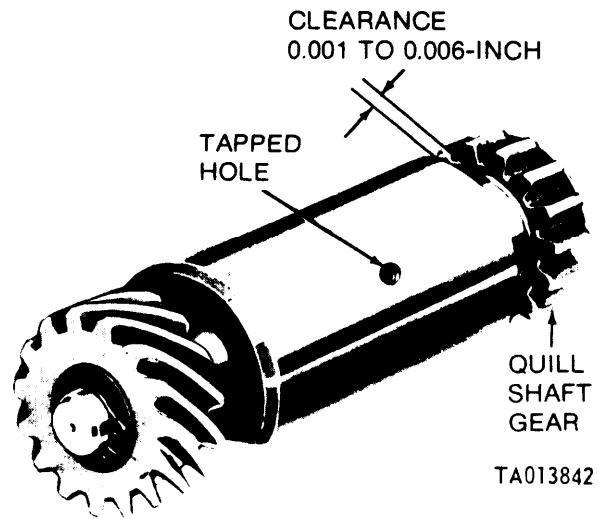

TA013842

Figure 3-104. Inspection of quill shaft assembly.

3-31. Repair of Camshaft Assembly. *a. Disassembly.* Disassemble camshaft assembly as follows:

(1) Refer to figure 3-105. Place camshaft and associated parts in a vise as shown. Straighten tabs on bearing retaining lockwasher (A) and remove bearing retaining locknut (B), using wrench-5120-870-6926. Remove lockwasher.

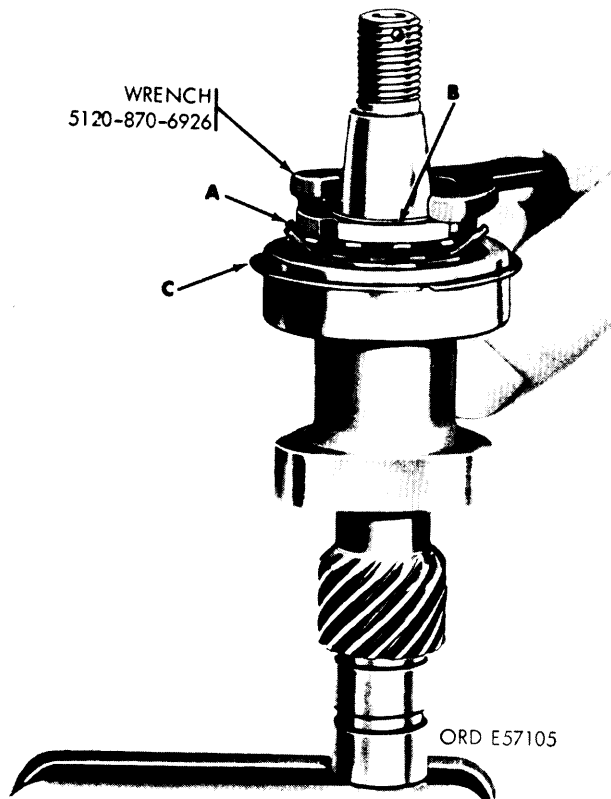

Figure 3-105. Removing or installing bearing retaining locknut using wrench.

(2) Refer to figure 3-106. Press camshaft ball bearing from camshaft.

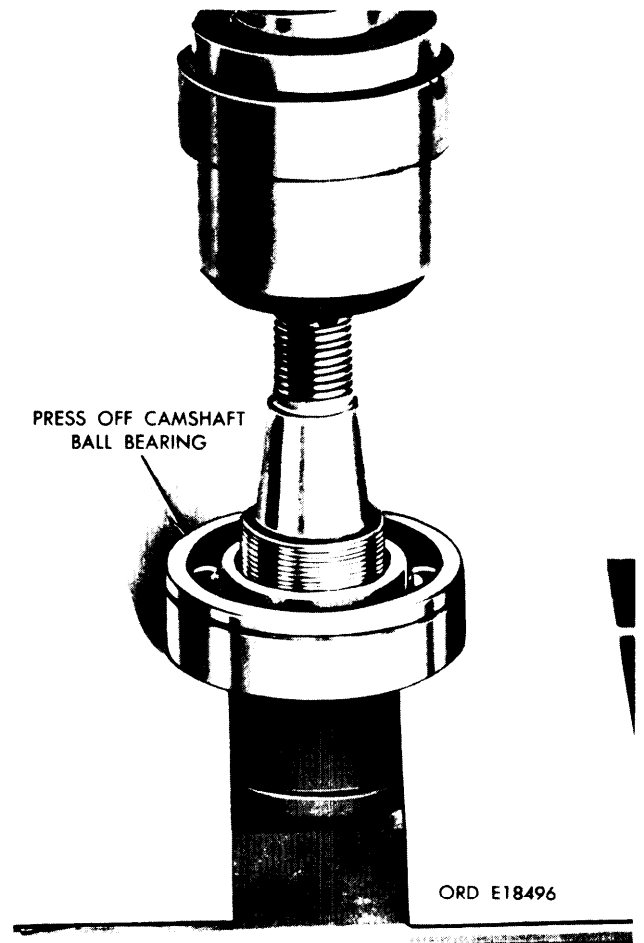

Figure 3-106. Pressing camshaft ball bearing from camshaft.

b. Inspection and Repair. Inspect and repair the cam shaft assembly as follows:

(1) Examine the bearing surfaces of the cam shaft (H- 1, fig. 3-109) for scratches and wear patterns. Minor scratches may be removed with crocus cloth. When wear patterns are visible, replace the camshaft. Check the camshaft against the limits specified in the repair standards (para 3-60) and replace when it does not meet these requirements.

(2) Check the camshaft ball bearing (G-2, fig. 3-109) against the limits specified in the repair standards (para 3-60) and replace when it does not meet these requirements. Refer to TM 9-214 for care and maintenance of ball bearings.

c. Assembly. Assemble the camshaft assembly as follows:

(1) Refer to figure 3-107. Position remover and replacer on camshaft (A) in an arbor press and install camshaft ball bearing (B) with retaining ring groove away from camshaft as shown.

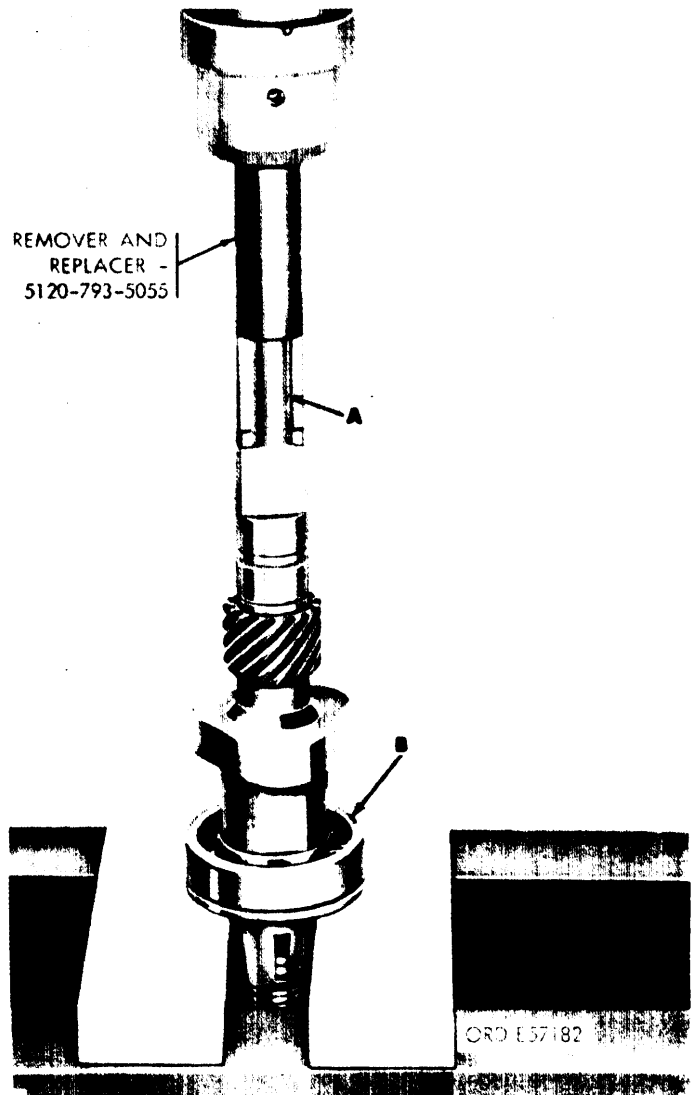

Figure 3-107. Installing camshaft ball bearing on camshaft using remover and replacer.

(2) Refer to figure 3-105 and install bearing retaining locknut and related parts on camshaft. Torque tighten nut to 25-40 foot-pounds. Secure nut by bending tab of lockwasher into notch of locknut.

3-32. Repair of Fuel Injection Pump Housing. *a.* Inspect the injection pump housing (fig. 3-108) for cracks, nicks, or burs. Replace the pump when housing is cracked. Minor nicks or burs may be removed with a fine mill file or crocus cloth. Check the injection pump housing against the limits specified in the repair standards (para 3-60) and replace the pump when housing does not meet these requirements.

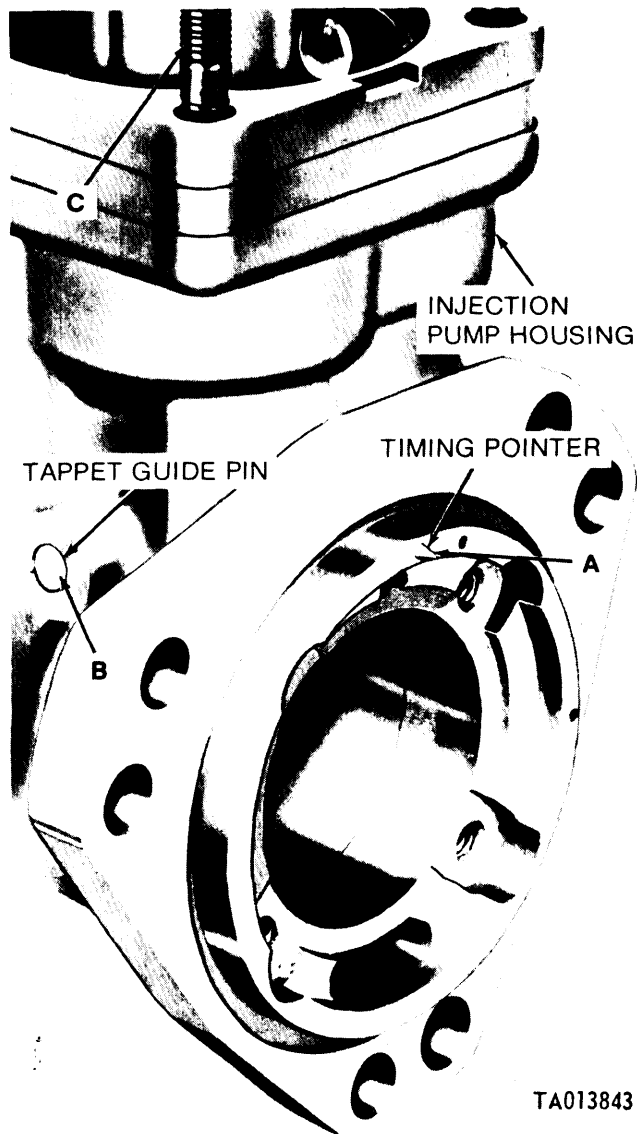

Figure 3-108. Location of timing pointer and tappet guide pin.

b. Examine the timing pointer (A), tappet guide pin (B), and studs (C) for wear and damage. If any part is defective replace the pump assembly.

c. Inspect the camshaft bushing type bearing for score marks and wear patterns. Replace housing if bearing is damaged or worn. Retain housing for possible repair if bearing is defective.

3-33. Repair of Miscellaneous Components. *a. General.* The following paragraphs cover inspection and repair of miscellaneous components. The components covered in these paragraphs are external components and are not necessarily part of the assemblies repaired in the preceding paragraphs.

NOTE

Paragraph *b* applies only to code F and G pumps.

b. Repair of Oil Filter. Refer to figure 3-20. Clean oil filter (C). Inspect oil filter screw (A) for stripped threads or other damage. If filter (C) or screw (A) are damaged replace the hydraulic head assembly and plug housing opening using kit - 5704374 to plug oil passage in pump housing.

c. Repair of Oil Hose Assembly. Refer to figure 3-35. Inspect oil hose assembly (X) for damage, damaged fittings, stripped threads, and deterioration to hose structure. Replace hose assembly if damaged. Check elbow (Y) and tee (W) for cracks and damaged threads. Replace if damaged.

d. Repair of Stop Plate and Bridge Assembly. (Code G pumps only.) Refer to figure 3-12. Inspect stop plate (F) for wear or damaged threads. Install nut (E) and lockwasher (D) on screw of stop plate (F). Position bridge (C) on stop plate screw with approximately seven exposed threads between nut (E) and stop plate. Secure with lockwasher (B) and nut (A).

e. Repair of Plastic Lines and Fittings. There is no repair of plastic lines and fittings, figures 3-29 through 3-33. Inspect for damage and replace lines and fittings as required.

Section IV. ASSEMBLY OF FUEL INJECTION PUMP FROM SUBASSEMBLIES

3-34. General. *a.* Assembly of the metering and distributing fuel injection pump should be performed in figure number sequence and in accordance with the instructions provided with each illustration.

b. The fuel injection pump is a precision accessory whose proper operation depends on cleanliness of all parts. Precision lapped surfaces of rotating parts must be free of dust and dirt at all times. During assembly, keep working area, parts, hands, and clothing clean.

c. Immediately before assembly, coat all bearings, shafts, and contact surfaces with appropriate engine oil. Always use new gaskets and packings. Apply grease, Federal Specification W-P-236, on tight fitting preformed packings to aid in their installation.

3-35. Repair Kits. *a. General.* A number of repair kits are supplied to repair the fuel injection pump. Repair kits for the governor linkage, and timing device unit assembly are listed in appendix B. The kits were applied in the previous section during assembly of the individual components. The

following are additional kits for repair of the fuel injection pump.

b. Shim Set. The shim set contains outer, and inner spring spacers. The spacers are used to adjust the governor inner and outer spring tensions. The spacer set is listed in the repair list section in appendix B.

c. Gasket and Preformed Packing Set. All gaskets and preformed packings in the gaskets and preformed packings set will be replaced during repair of fuel injection pump.

3-36. Identification of Metering and Distributing Fuel Injection Pump Components.

a. General. To identify, locate, and show relationship of components of the injection pump, refer to the exploded views in the repair section of this chapter.

b. Exploded View Illustrations. Figures 3-29 through 3-37, 3-70, 3-71, 3-97; and 3-109 show the injection pump and components. Refer to the illustrations to identify parts and aid in the assembly of the pump.

KEY to fig 3-109

A Timing device assembly
 B 1/4x11/16 machine screw
 C Retaining plate lockwasher
 D Bearing retaining plate
 E Bearing retaining lock nut
 F Bearing retaining lockwasher
 G Camshaft ball bearing assembly
 1 Bearing retaining ring
 2 Camshaft ball bearing
 H Camshaft assembly
 1 Camshaft
 2 Assembled washer screw
 J Timing pointer
 K Tappet assembly
 L Plunger spring seat
 M Head lower preformed packing
 N Hydraulic head assembly
 P Stud sleeve
 Q Hydraulic head nut
 R Head upper preformed packing
 S Spring retaining ring

T Plunger outer spring
 U Injection pump housing assembly
 1 Injection pump housing
 2 Pump housing stud
 3 Tappet guide pin
 V 1/4x5/8 machine screw
 W Copper gasket
 X Governor weight and spider assembly
 Y Quill shaft assembly
 Z Quill shaft pad gasket
 AA 1/4x5/8 machine screw
 BB Copper gasket
 CC Quill shaft pad cover
 DD 3/8x1-1/4 machine screw
 EE 3/8-inch lockwasher
 FF 3/8-inch flat washer
 CC Pump housing packing
 HH Camshaft Woodruff key
 JJ 3/8-inch lockwasher
 KK 3/8x5-7/8 machine screw

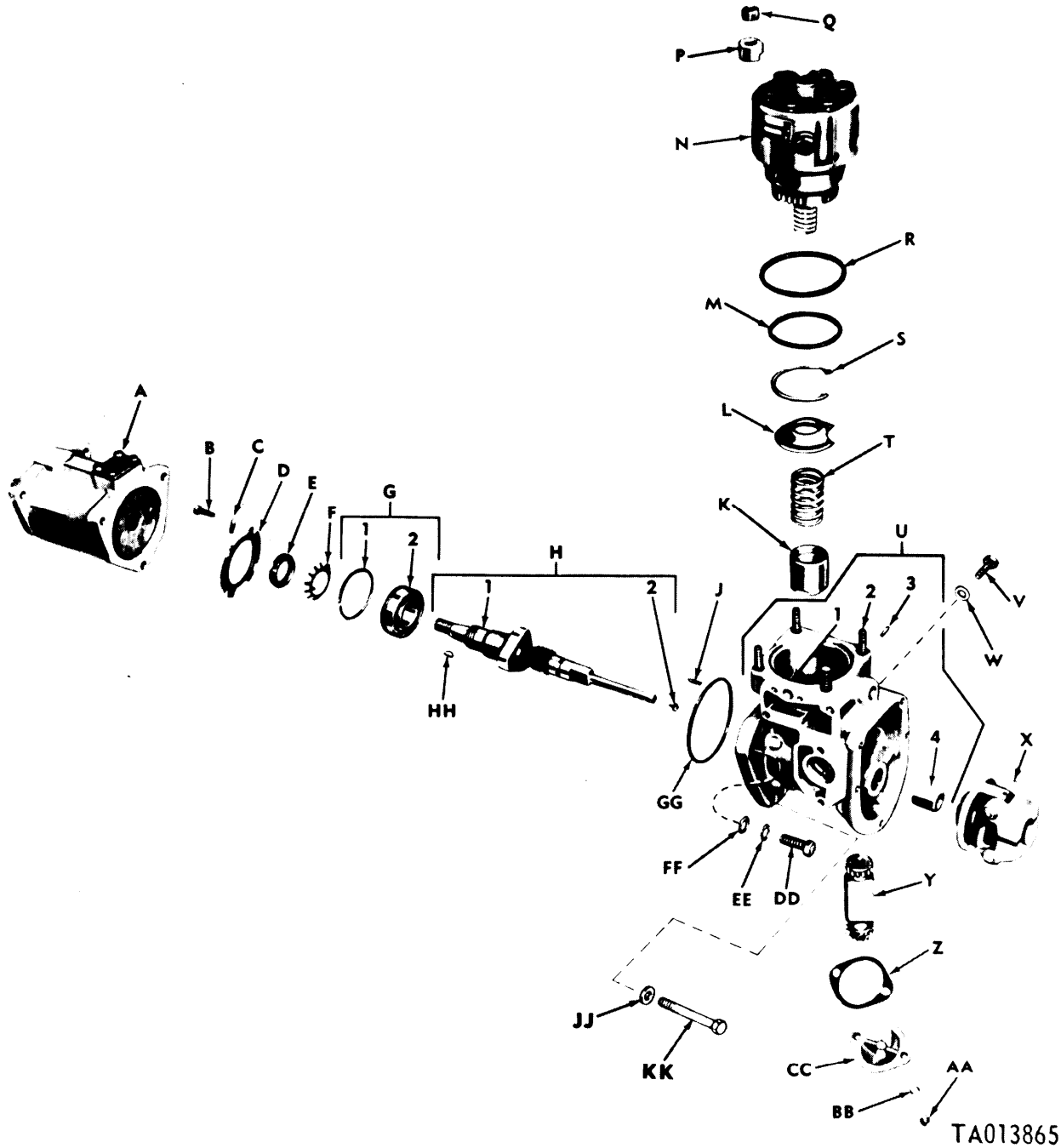

TA013865

Figure 3-109. Fuel injection pump housing, hydraulic head assembly and related parts, exploded view.

3-37. Installation of Camshaft. a. Assembly. The cam shaft ball bearing was installed on the camshaft during repair (para 3-31).

NOTE
Refer to figure 3-110 for identification of injection pump housing.

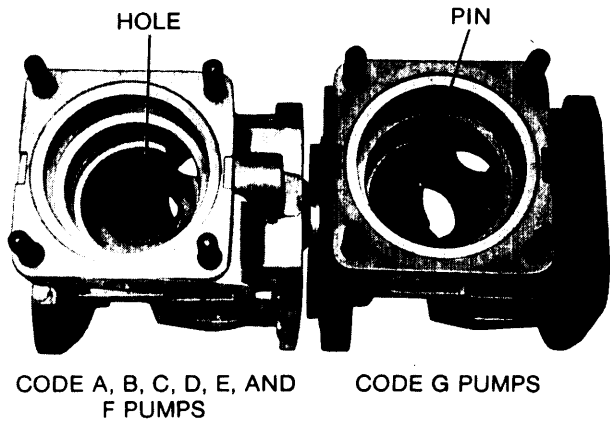

TA013766

Figure 3-110. Identification of injection pump housings.

b. Installation. Install camshaft in fuel injection pump housing as follows:

- (1) Refer to figure 3-111. Place pump housing (A) on bed of arbor press and install camshaft and associated parts (B) in injection pump housing.

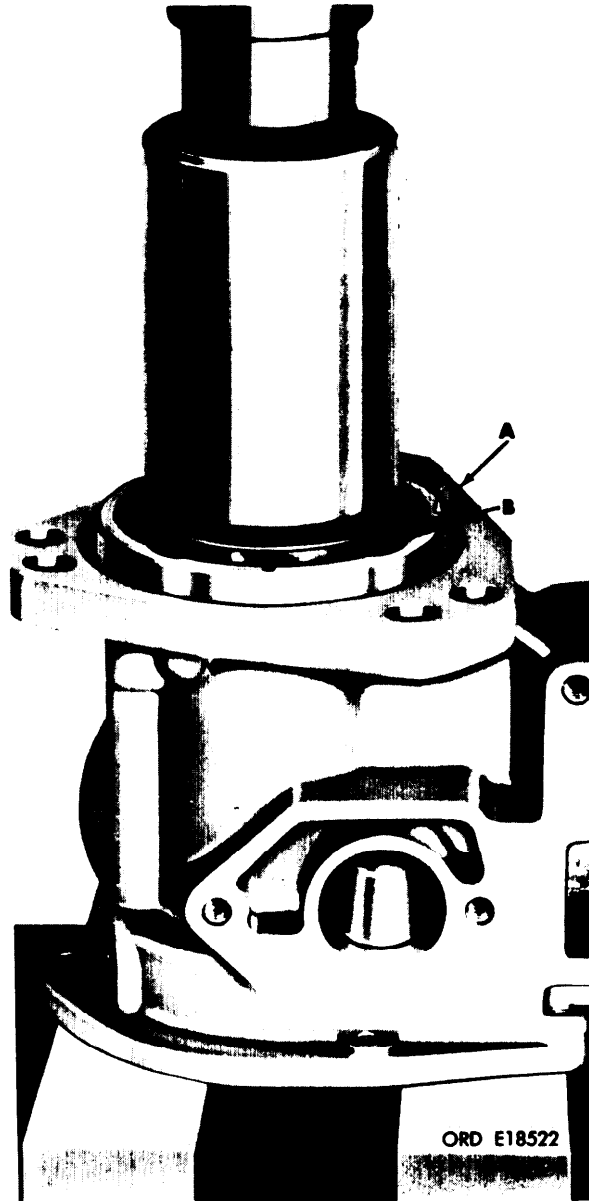

Figure 3-111. Installing camshaft and associated parts in pump housing.

(2) Refer to figure 3-112. Install fixture — 4910-870-2128 on injection pump housing (A) and install fixture in a vise. Position bearing retaining plate (B) so CLW (clockwise) line is as shown, Install four lockwashers (C) and machine screws (D). Tighten screws and bend tabs of lockwashers over screw heads to secure screws.

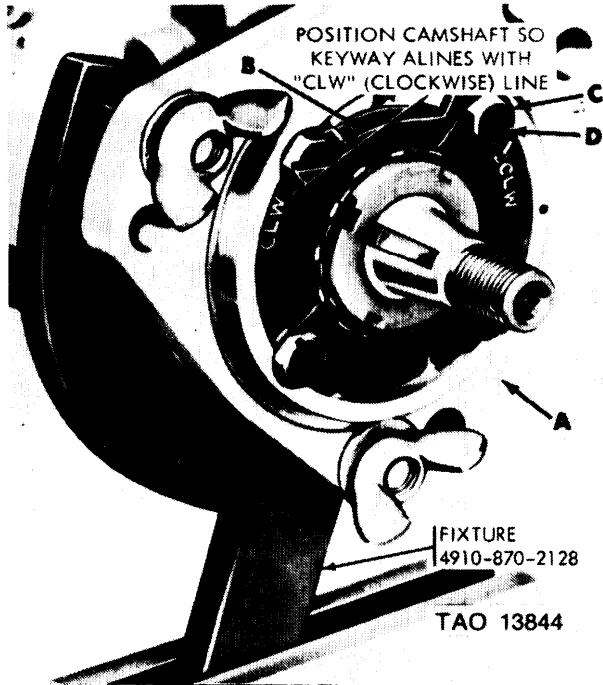

Figure 3-112. Installing bearing retaining plate using fixture.

3-38. Installation of Quill Shaft Assembly

a. Position camshaft as shown in figure 3-113, before installing quill shaft assembly.

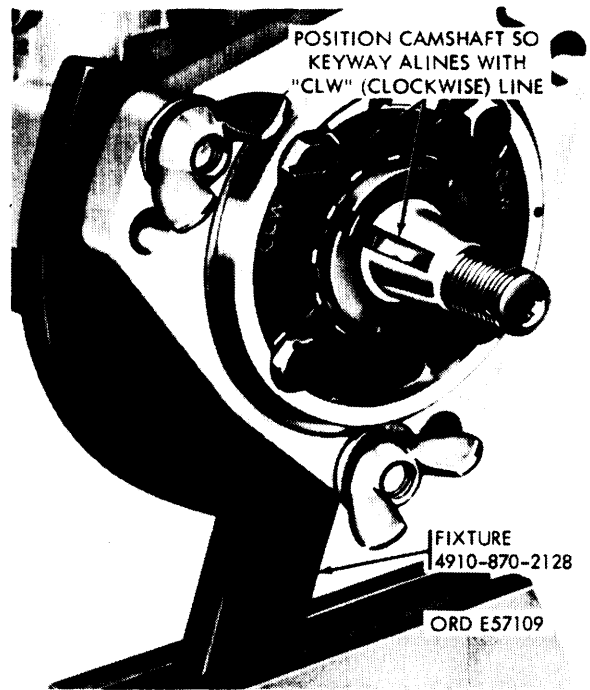

Figure 3-113. Positioning camshaft prior to installing quill shaft assembly.

b. Refer to figure 3-114. Install fixture — 4910-870-2131 as shown to lock camshaft and prevent rotation

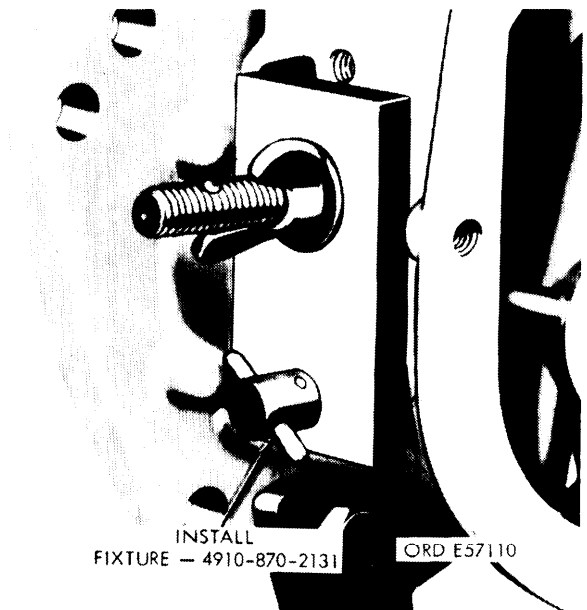

Figure 3-114. Locking camshaft to prevent rotation.

c. Refer to figure 3-115. Insert quill shaft assembly.

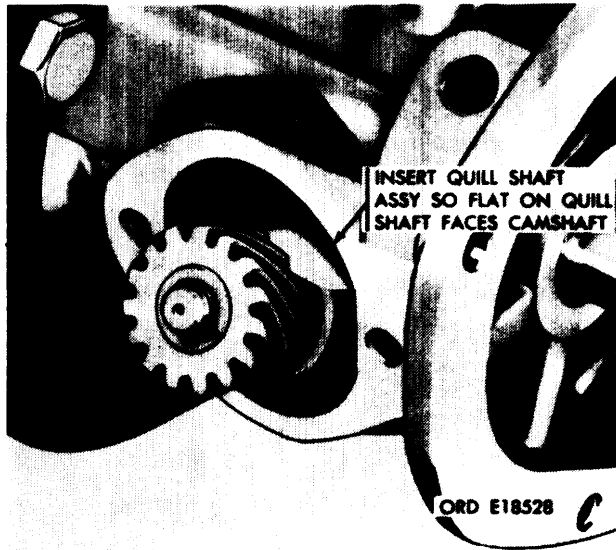

Figure 3-115. Installing quill shaft assembly.

d. Refer to figure 3-116. Install quill shaft assembly so open tooth aligns with housing mark (A). Install copper gasket (B) and machine screw (C). Torque tighten machine screw to 80-90 inch-pounds and secure with locking wire.

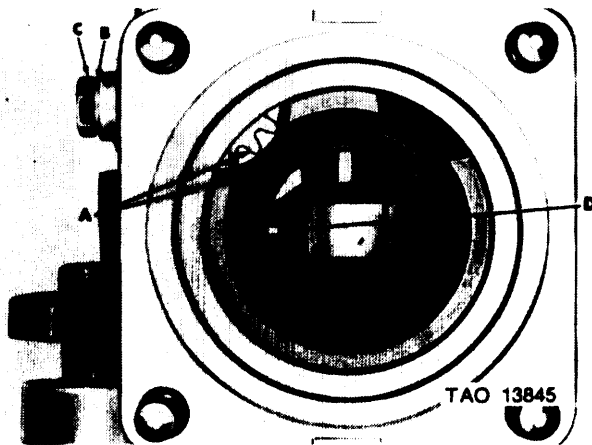

Figure 3-116. Installing quill shaft assembly in housing.

e. Refer to figure 3-117. Coat both sides of quill shaft pad gasket with a thin coat of sealer, MIL-S-45180 or equivalent. Install quill shaft pad gasket (A) and quill shaft pad cover (B). Secure cover with two copper gaskets (C) and machine screws (D). Torque tighten machine screws to 50-60 inch-pounds. Screws will be lock wired at governor installation (para 3-43).

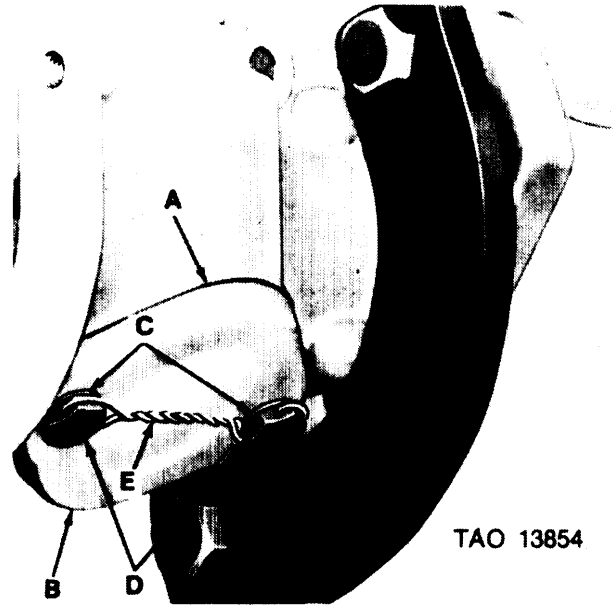

Figure 3-117. Installing quill shaft pad cover.

3-39. Installation of Tappet Assembly.

a. *Assembly.* The tappet assembly was assembled during repair (para 3-29).

NOTE

Refer to figure 3-118 for selection of tappet, spring, and spring seat.

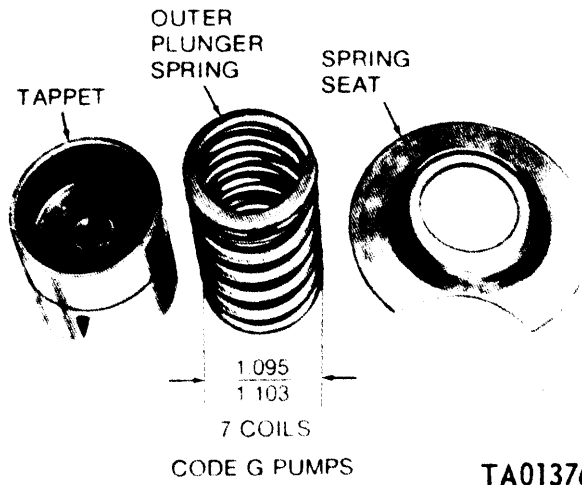
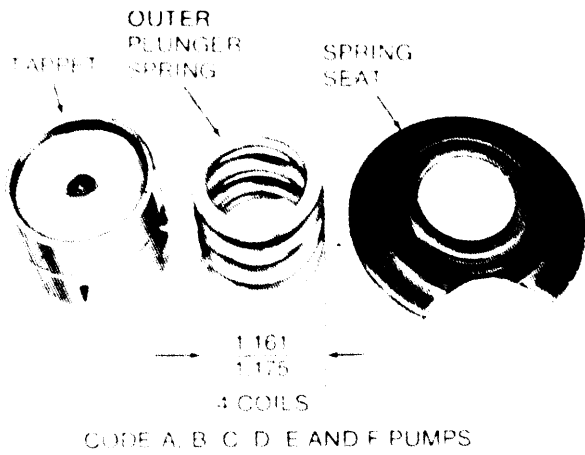

Figure 3-118. Identification of tappet, outer plunger spring and spring seat.

b. Installation. Install tappet assembly as follows:

- (1) Refer to figure 3-119. Install tappet assembly after aligning tappet slot with tappet guide pin (D, fig. 3-116).

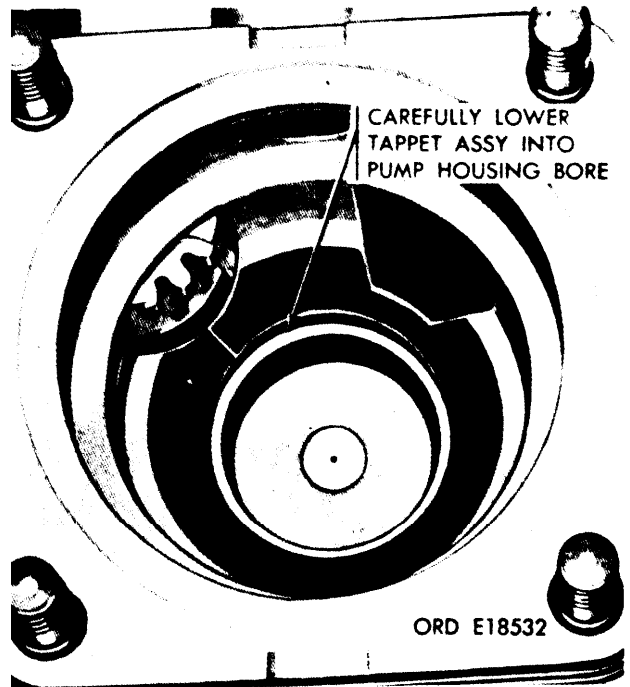

Figure 3-119. Installing tappet assembly.
 (2) Refer to figure 3-120. Install plunger outer spring (A) and spring seat (B).

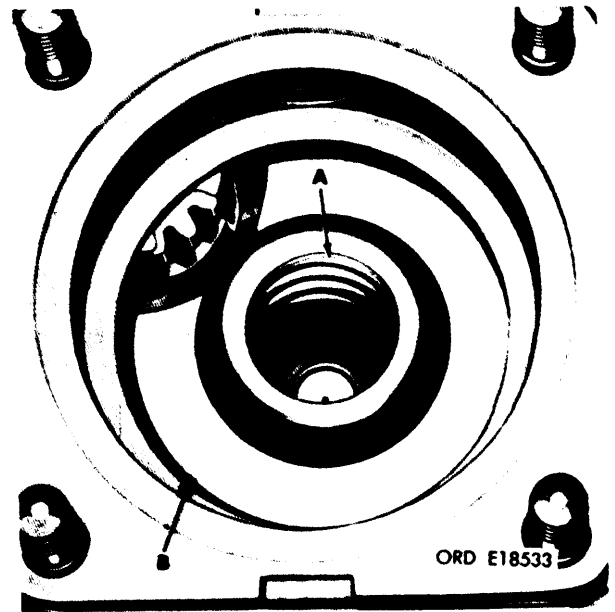

Figure 3-120. Installing plunger spring seat.

(3) Refer to figure 3-121. Position compressor and secure with two stud sleeves (A) and hydraulic head nuts (B). Turn thumb screw (C) clockwise to compress plunger spring seat. Install spring retaining ring (D) using suitable pliers. Release spring tension by turning thumb screw counterclockwise and remove the compressor.

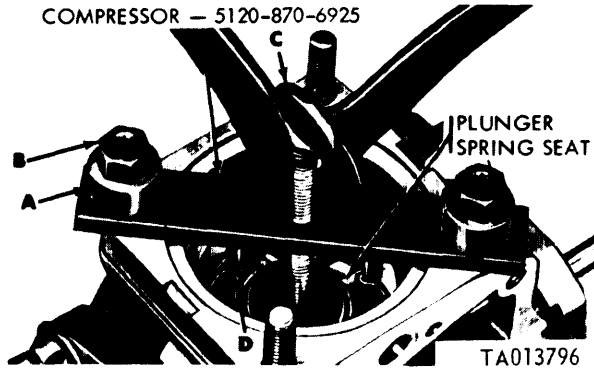

Figure 3-121. Installing tappet spring retaining ring using compressor.

3-40. Installation of Hydraulic Head Assembly.

NOTE

For proper selection of hydraulic head assemblies refer to table 3-2.

a. *Assembly.* The hydraulic head was inspected and assembled during repair (para 3-28).

b. *Installation.*

CAUTION

Do not force the hydraulic head into the housing. A slight pressure will be required to seat the preformed packings in the housing.

(1) Refer to figure 3-122. Position hydraulic head assembly (A) on injection pump housing so plunger sleeve slot faces opening, and align slotted tooth of plunger drive gear with arrow on injection pump housing. Install four stud sleeves (B) and hydraulic head nuts (C). Torque tighten nuts to 18-20 foot-pounds.

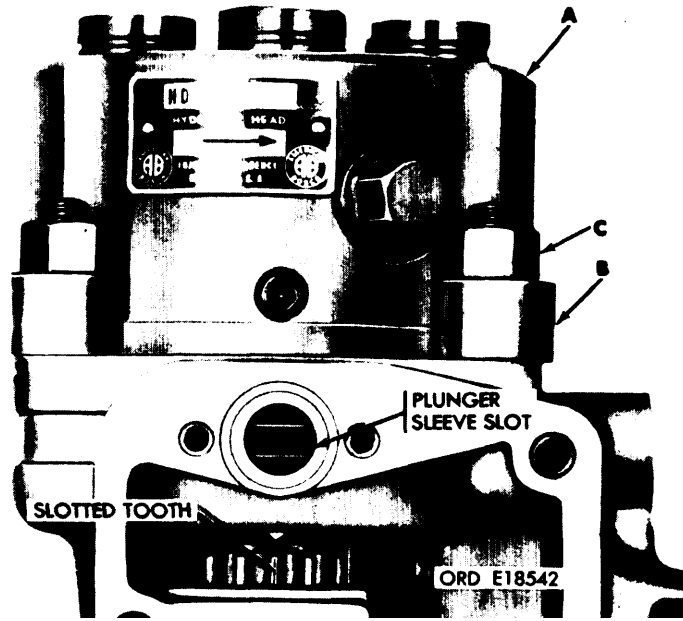

Figure 3-122. Installing hydraulic head assembly.

NOTE

Sub-paragraphs (2), (3), and (4) below apply to code F and G pumps only.

(2) Refer to figure 3-123. Install filter screw copper gasket (A) and oil filter (B) on filter screw (D). Apply grease, Federal specification VV-P-236, to filter screw packing (C), and install on oil filter screw (D). Install oil filter screw and associated parts. Torque tighten screw to 20-25 foot-pounds.

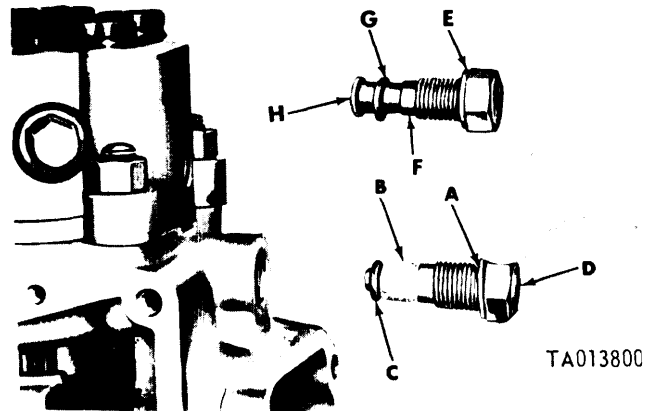
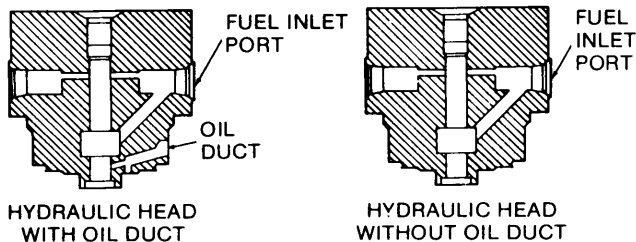

Figure 3-123. Installing oil filter.

(3) Refer to figure 3-124. If hydraulic head assemblies HD9070A or HD9085A with an oil duct are replaced by a later model hydraulic head assembly, it will be necessary to plug the oil duct in the pump housing utilizing kit 5704374. Refer to table 3-2 to determine correct hydraulic head application.

(4) Refer to figure 3-123. Lubricate and install packing (G) on pin-(H). Install washer (E) on screw (F) and assemble pin and screw. Install screw assembly in pump housing and torque tighten to 20-25 foot-pounds.



TA01176A

Figure 3-124. Identification of hydraulic heads with oil lubrication ducts.

Table 3-2. Selection of Hydraulic Head

Pump code	Hydraulic head part number		
	Federal stock No.	American Bosch No.	Ordnance No.
A	2910-762-4623	HD90111A (Note 1)	11662498
B	2910-908-6319;	HD9083A	10947154
C, D, and E	2910-828-7167.	HD90101A, (Note 1)	11602722.
	2910-908-6318;	HD9082A	10947559
F	2910-828-7176.	HD90100A.	11602721.
	2910-908-6319;	HD9083A	10947154
G	2910-828-7167.	HD9085A (Note 2)	
	2910-871-5435;	HD90101A (Note 1)	11602722
	2910-006-7501.	HD9065A (Note 2)	10914599
		HD90113A	

Note 1. Hydraulic heads HD90111A and HD90101A are interchangeable. The difference is the angular location of the fuel inlet fitting.

Note 2. Hydraulic heads HD9065A and HD9085A require an oil filter and plug.

3-41. Installation of Timing Device Assembly.

a. Assembly.

(1) Refer to figure 3-125. Install woodruff key on

camshaft. Remove fuel injection pump from fixture and then remove fixture from vise.

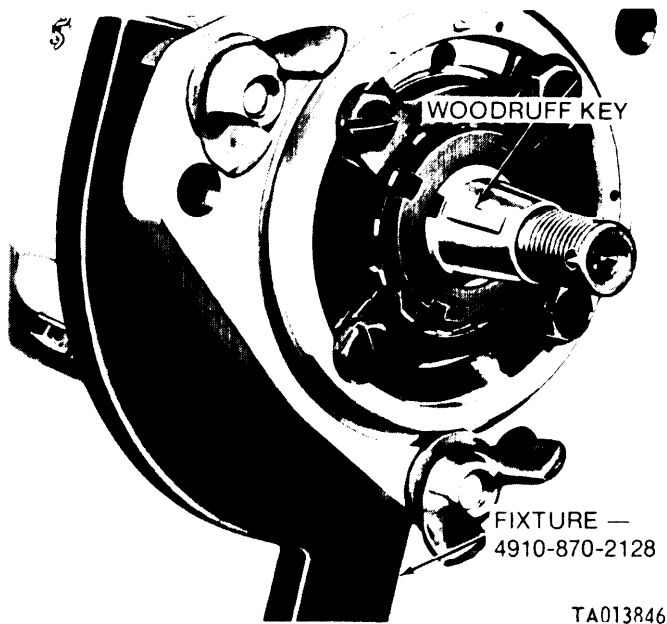

Figure 3-125. Removing fuel injection pump and fixture from vise.

(2) Refer to figure 3-126. Lubricate and install pump housing packing (A). Install timing device hub (B) on camshaft, aligning slot with woodruff key (fig. 3-125). Install camshaft nut (C) and torque tighten nut to 50-55 foot-pounds. Install camshaft nut setscrew (D) and torque tighten setscrew to 25-28 foot-pounds. Remove fixture from injection pump housing.

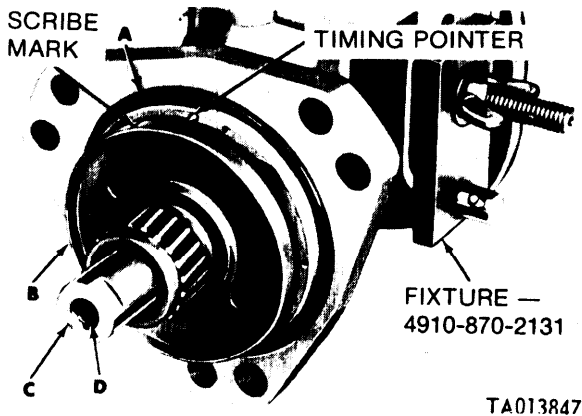

Figure 3-126. Installing timing device hub on camshaft.

NOTE

It is possible to have pointer (A, fig. 3-108) near the timing device hub scribe mark without alinement of arrow and slotted tooth being shown in the housing window (fig. 3-122). If this occurs, rotate the timing device hub one complete turn.

(3) Refer to figure 3-127. Install timing cover gasket (A) and timing cover (B). Secure cover with four machine screws (C) and lockwashers (D).

NOTE

If the fuel pump is to be tested immediately after assembly, do not secure the timing cover until adjustments are made as described in paragraphs 3-50 through 3-58.

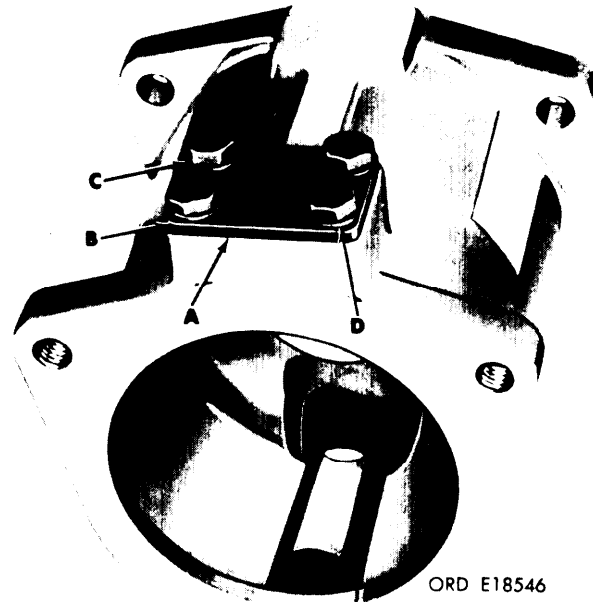

Figure 3-127. Installing timing cover.

(4) Refer to figure 3-128. Install sliding gear (A) on timing device hub. Select and fit proper sliding gear spacer (B) to give 2.180 to 2.200-inch dimension. Remove sliding gear and sliding gear spacer and retain for future assembly.

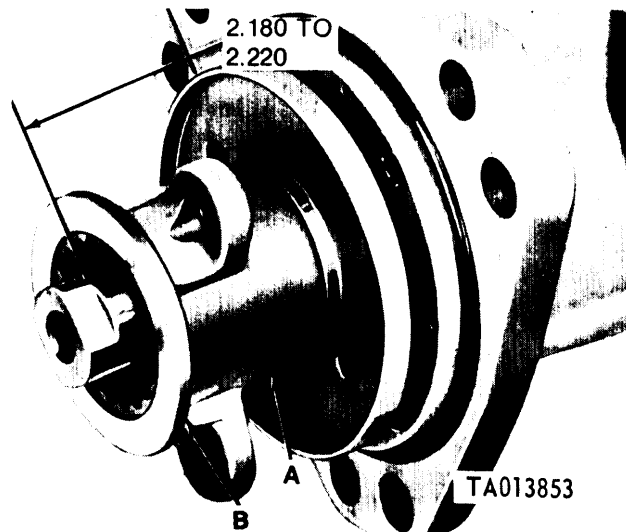

Figure 3-128. Selecting proper sliding gear spacer.

(5) Refer to figure 3-129. Install end play spacer (A), spider assembly (B), and weight and spider thrust plate (C) on camshaft.

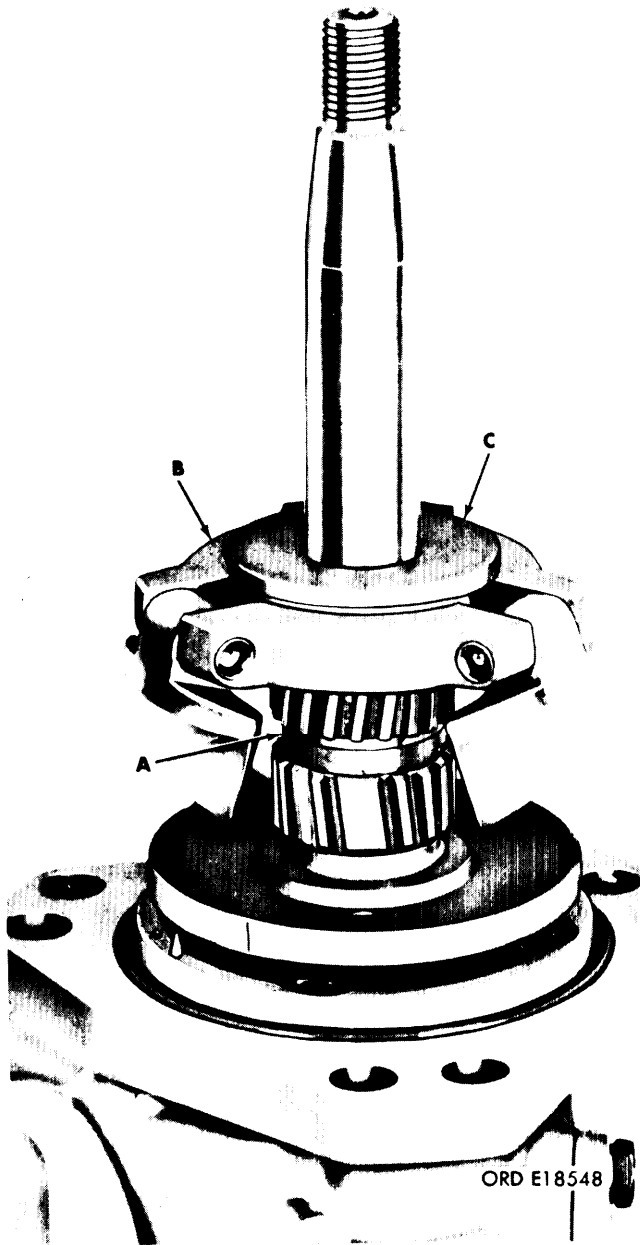

Figure 3-129. Positioning spider assembly on camshaft prior to checking end play.

(6) Refer to figure 3-130. Install timing device housing (A) and secure with two flat washers (B), lockwashers (C), and machine screws (D). Torque tighten machine screws to 17-20 foot-pounds.

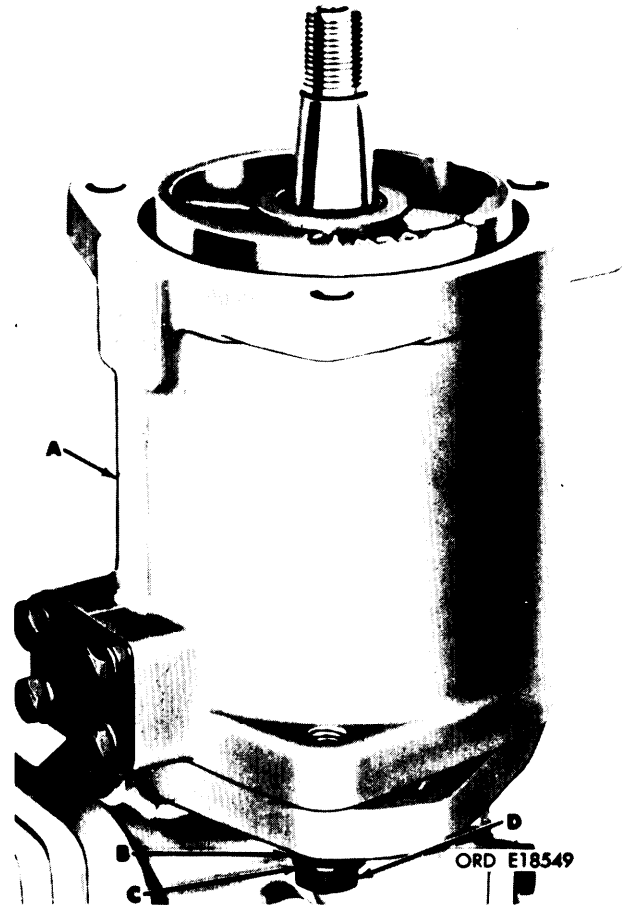

Figure 3-130. Positioning timing device housing prior to checking end play.

(7) Refer to figure 3-131. Mount a suitable dial indicator (A) on fuel injection pump. Move spider assembly (B) up and down and take indicator reading to obtain end play. End play must be between 0.003 and 0.018-inch. Remove timing device housing (C) and previously assembled parts (4) and (5) above).

NOTE

If end play is within the above limits, retain end play spacer for future assembly. If end play is less than 0.003-inch, install a thinner end play spacer and recheck end play. If end play is more than 0.018-inch, install a thicker end play spacer and recheck end play.

NOTE

For proper selection of timing device springs refer to figure 3-132.

(8 Refer to figure 3-133. Install three timing device springs (A) and sliding gear (B) on timing device. Install proper sliding gear spacer (C) as determined in (7) above.

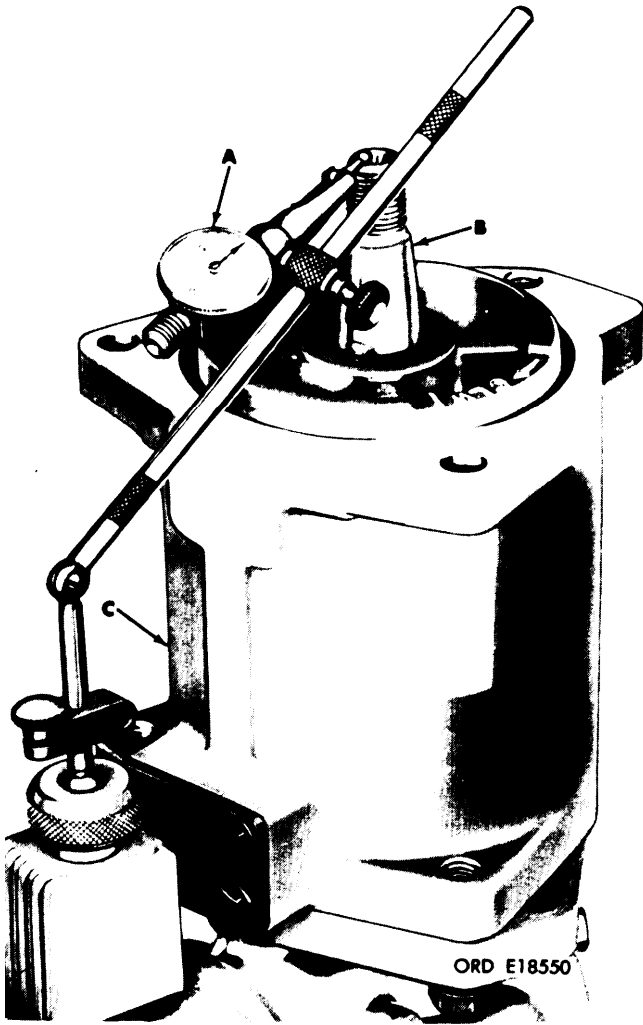
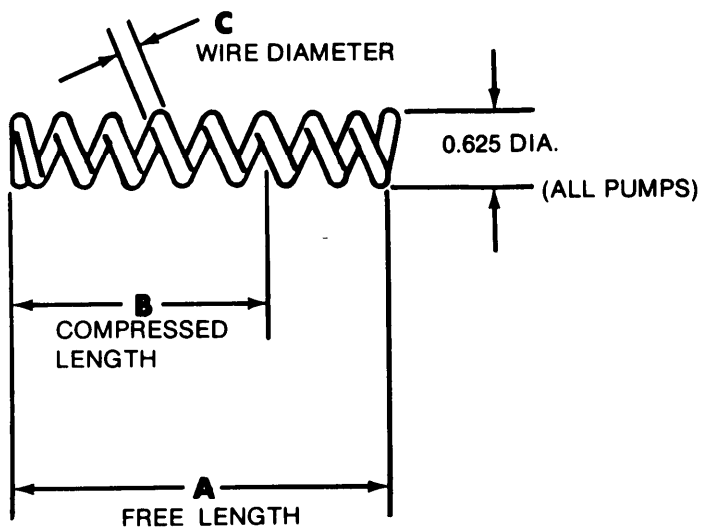

Figure 3-131. Checking spider assembly end play.

Injection Pump Code	American-Bosch Part No.	A Free Length	B Compressed Length	Compression Load	C Wire Dia.
A	SP857-3	1.533	1.000	51.3-56.7 lbs.	0.093
B,F,G	SP9041	1.542	1.000	35.3-39.3 lbs.	0.085
C,,D,E	SP9043	1.773	1.000	40.6-44.6 lbs.	0.085



TA013769

Figure 3-132. Selection and identification of timing device springs.

(9) Refer to figure 3-134. Install proper end play spacer (A, fig. 3-129) as determined in (7) above. Install spider assembly (A) and weight and spider thrust plate (B).

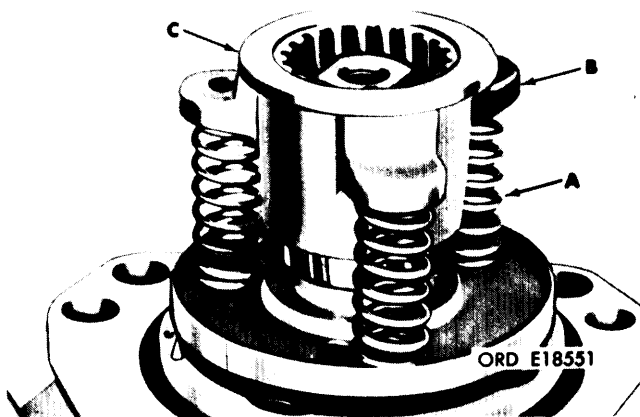

Figure 3-133. Installing sliding gear.

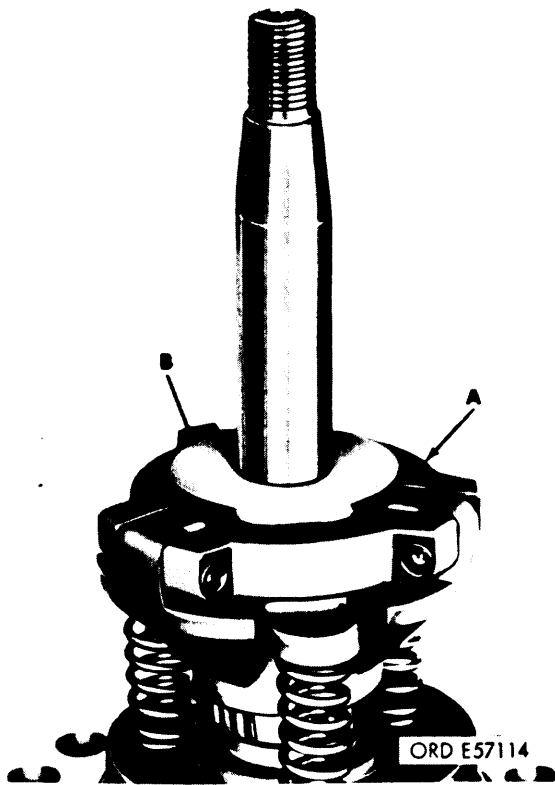

Figure 3-134. Installing spider assembly, spacer, and thrust plate.

b. *Installation.* Install the timing device assembly as follows:

(1) Refer to figure 3-135. Install bolt (F) in pump and timing device housing before assembly of timing device housing to pump housing. Install timing device housing (A), after checking to see if pump housing packing is in position, and secure with two flat washers (B), lockwashers (C), and machine screws (D). Torque tighten machine screws to 17-20 foot-pounds. Install housing packing (E).

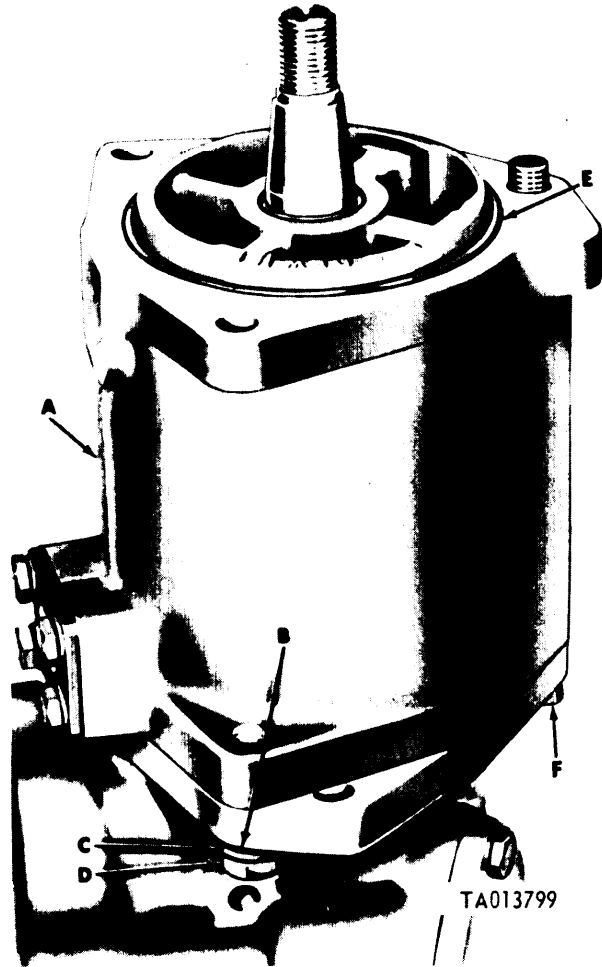

Figure 3-135. Installing timing device housing.

(2) Refer to figure 3-136. Install pipe-to-tube elbow (C), pipe-to-tube tee (B), and oil distribution hose assembly (A).

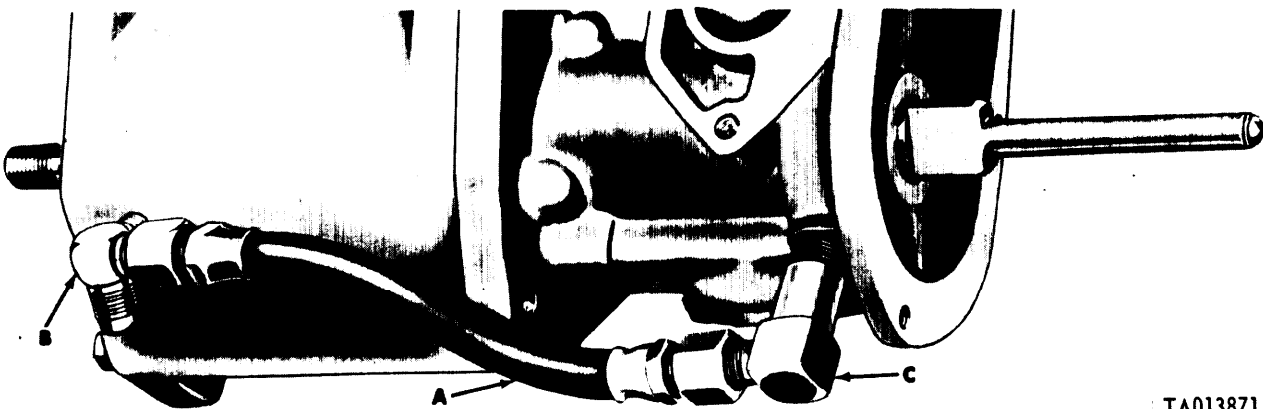

Figure 3-136. Installing oil distribution hose assembly and fittings.

3-42. Installation of Governor Weight and Spider Assembly.

NOTE

If a new governor weight and spider assembly was drawn from supply, or if it is a serviceable part, refer to figure 3-93 and check friction drive spider slippage; it must be 48-73 pound-inches.

a. Refer to figure 3-137. Before installing, check weight and spider assembly extreme-open position (A). Extreme-open position (A) should not exceed 3.380 inches. If the open position exceeds this limit, replace complete assembly. After completing check, position injection pump housing (B) on an arbor press and position weight and spider assembly (D) on camshaft (C). Position remover and replacer over camshaft and press weight and spider assembly onto camshaft until flush with shoulder.

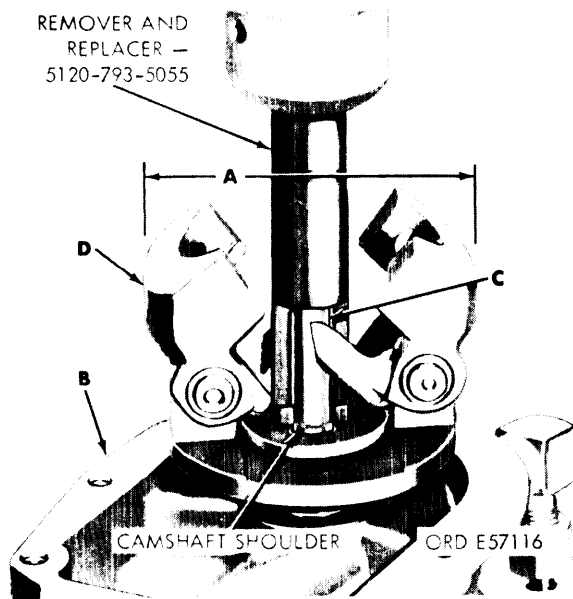
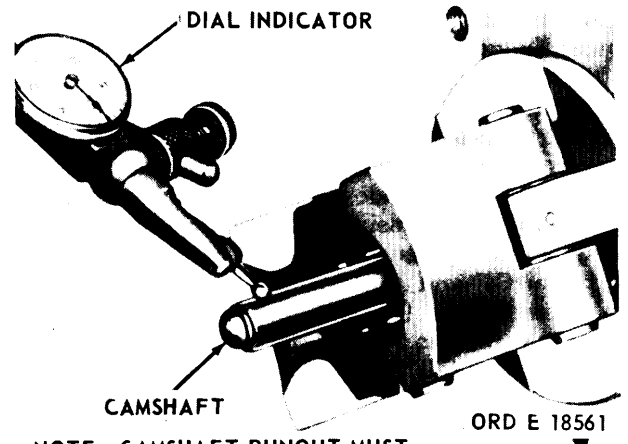

Figure 3-137. Checking extreme open position of governor weight and spider assembly and installing assembly using remover and replacer.

b. Refer to figure 3-138. Check camshaft run-out. Run-out should not exceed 0.003-inch. If camshaft run-out is between 0.003 to 0.005-inch straighten camshaft by suitable means. Replace the camshaft if camshaft cannot be straightened.



NOTE: CAMSHAFT RUNOUT MUST NOT EXCEED 0.003-IN.

Figure 3-138. Checking camshaft run-out.

c. Refer to figure 3-139. Check sliding sleeve travel. Remove sliding sleeve from governor housing, figure 3-89. Position sliding sleeve (A) in governor weight and spider assembly and rotate weights (B) completely outward (a above) 3.380-inch (maximum). Sliding sleeve travel must be a minimum of 0.630-inch. If travel is less than 0.630-inch, replace governor weight and spider assembly. Install sliding sleeve in governor housing, figure 3-89.

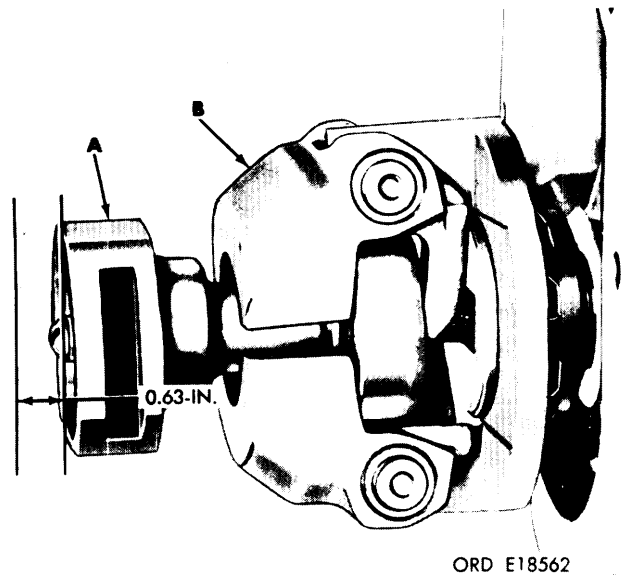

Figure 3-139. Checking sliding sleeve travel.

3-43. Installation of Governor.

a. Assembly. The governor was partially assembled during repair (para 3-25). The remainder of governor assembly is accomplished with the governor housing installed on the fuel injection pump housing.

b. Install Governor and Associated Parts. Refer to figure 3-140. Coat both sides of governor housing gasket with a suitable sealer MIL-S-45180. Install governor housing gasket (A). Guide fuel control rod through timing window and install governor (B) on injection pump housing with sliding sleeve engaging weight and spider assembly. Install two machine screws (C) and lockwashers (D). Install three machine screws (F) and lockwashers (G). Torque tighten screws to 50-80 inch-pounds and secure with locking wire (H). Lock wire bottom screw to quill shaft cover attaching screws. See figure 3-141.

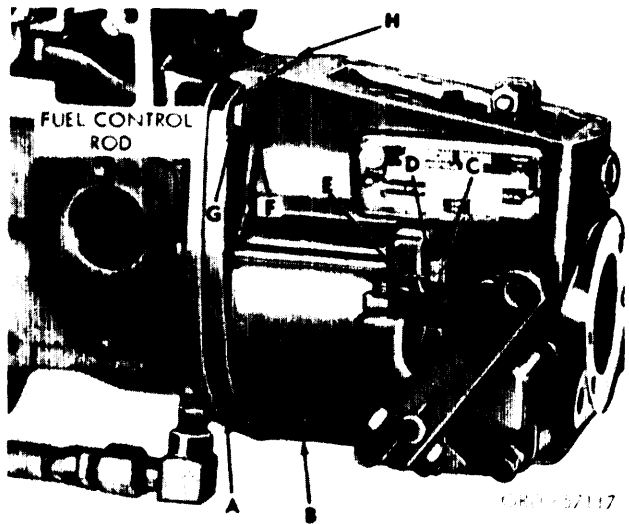

Figure 3-140. Installing governor on injection pump housing.

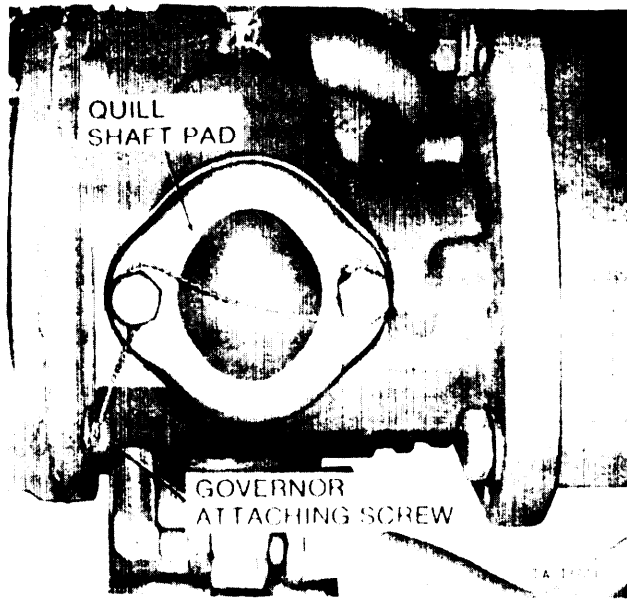

Figure 3-141. Securing quill shaft cover screws and bottom governor attaching screw.

c. Install Governor Springs.

NOTE

In order to select proper governor inner and outer spacers, the idle screw must be backed out flush with the bottom of the operating bearing flange, allowing the governor sliding sleeve to move inward to the extreme point of travel. Operating lever must be in idle position as shown in figure 3-140.

(1) Position operating lever so stop is in contact with low idle screw flange. Refer to figure 3-142 and 3-143 for selection of governor outer and inner springs.

Injection Pump Code	Federal Stock No.	A Free Length	B Compressed Length	Compression Load	C Wire Dia.
G	2910-846-4653 (SP 7951-11)	1.515-1.609	1.400	3.1-3.4 lbs.	0.099
A,B,D,E	5340-930-5140 (SP7951-12)	1.515-1.609	1.400	4.6-5.1 lbs.	0.105
E	2990-830-3882 (SP7951-13)	1.515-1.609	1.400	6.2-6.8	0.114

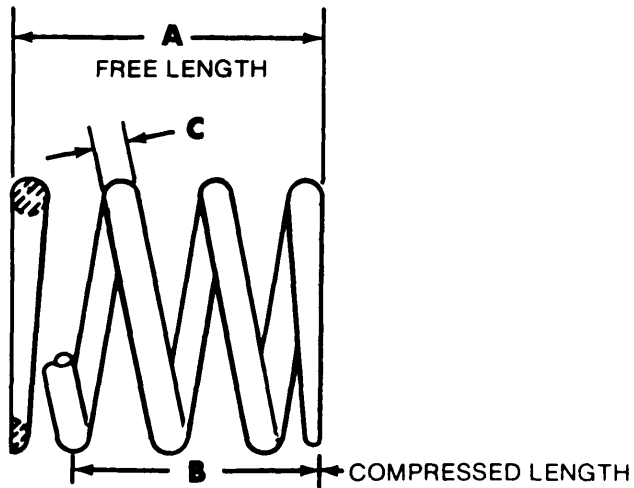

TA013771

Figure 3-142. Selection and identification of governor outer springs.

Injection Pump Code	Federal Stock No.	A Free Length	B Compressed Length	Compression Load	C Wire Dia.
A	2910-836-7316 (SP7950-16)	2.000	1.800	33.3 -36.8 lbs.	0.125
B,D,E,F,G	2910-850-3260 (SP7950-11)	2.000	1.800	28.5-31.5 lbs.	0.120
E	5360-081-5977 (SP7950-22)	2.000	1.800	25.6-28.4	0.120

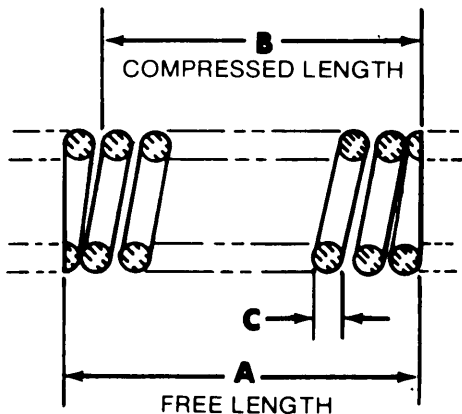

TA013772

Figure 3-143. Selection and identification of governor inner springs

(2) Refer to figure 3-144. Position governor outer spring (A) in housing and install gage as shown. Using gage and improvised tool, install outer spring spacers (B) to give dimension (C) between gage and governor housing. After determining

correct spacers, remove gage, selected outer spring spacers and governor outer spring in order that proper inner spring spacers ((3) below) may be selected. Retain selected spring spacers for future assembly.

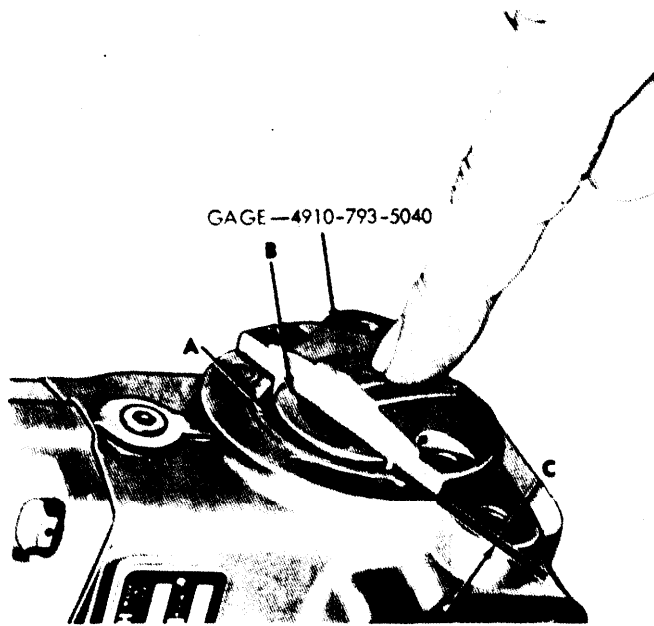

Injection Pump Code	Dimension C	Used On
A, C, D, E	0.040-0.060	Code A, C, D, E Pumps
B, F	0.020-0.040	Code B, F Pumps
G	0.080-0.100	Code G Pump

TA013848

Figure 3-144. Selecting proper outer spring spacers using gage.

(3) Refer to figure 3-145. Position governor inner spring (A) in housing and install gage as shown. Using gage and improvised tool, install inner spring spacers (B) to give dimension (C) between the spacers and gage. Remove gage, selected inner spring spacers, and governor inner spring. Retain selected spacers for future assembly.

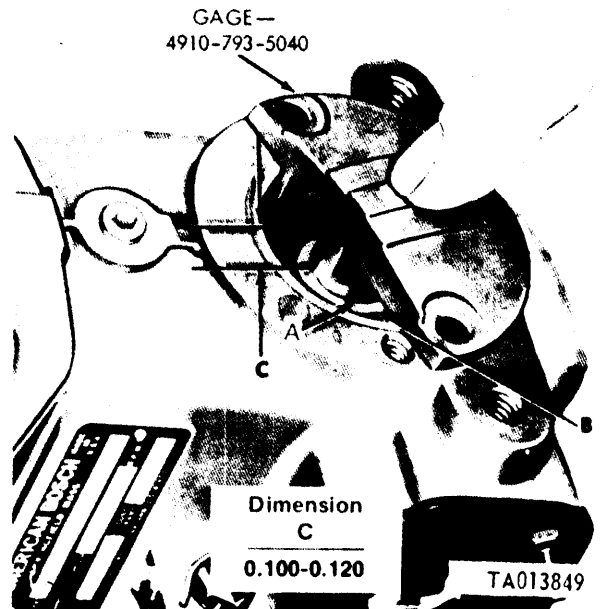

Figure 3-145. Selecting proper inner spring spacers using gage.

(4) Refer to figure 3-146. Install governor inner spring (A), governor outer spring (B), proper inner spring spacers (C), and proper outer spring spacers (D) as determined in (2) and (3) above.

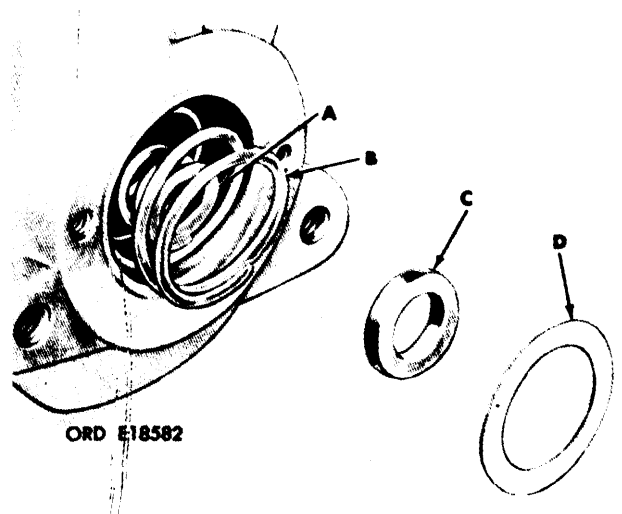

Figure 3-146. Installing inner and outer springs and spacers.

(5) Refer to figure 3-147. Coat end cap gasket with a thin coat of er, MIL-S-45180 on side facing end cap. Install end cap gasket (A) and governor end cap (B) and secure with two machine screws (C) and lockwashers (D). Torque tighten screws to 50-60 inch-pounds and secure with locking wire (E).

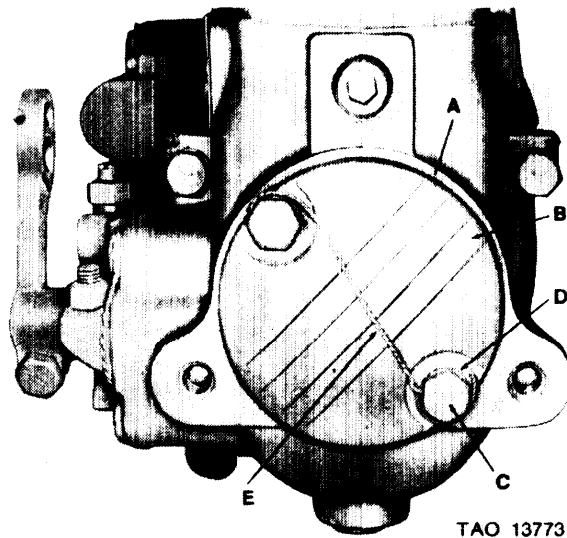

Figure 3-147. Installing governor end cap.

3-44. Installation of Fuel Control Unit Assembly

NOTE

See figures 3-48, 3-49 and 3-50 for identification of control units.

a. Refer to figure 3-148. Position plunger sleeve slot at bottom of travel, as shown, by pressing down on sleeve. The fuel control unit lever must be in an idle position before inserting plunger sleeve pin into plunger sleeve slot.

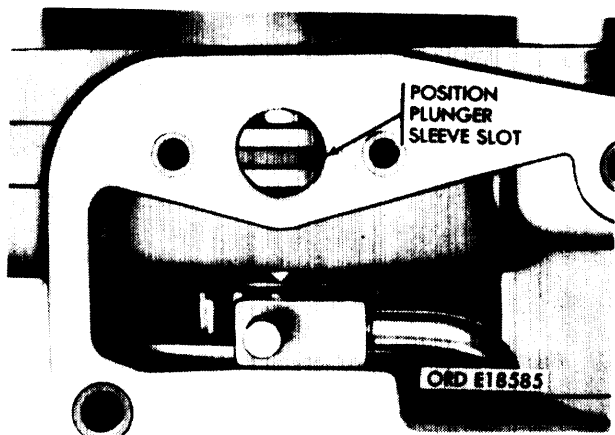

Figure 3-148. Location of plunger sleeve slot.

b. Refer to figure 3-149. Install fuel control unit assembly with new preformed packing, so that plunger sleeve pin (A, fig. 3-47) engages plunger sleeve slot (fig. 3-148). To check for engagement operate lever back and forth. Lever should move through about a 50° angle between and below retainer mounting holes. If this movement occurs, pin is engaged in sleeve slot. If not, remove and reinstall control unit and engage plunger sleeve pin in plunger sleeve slot.

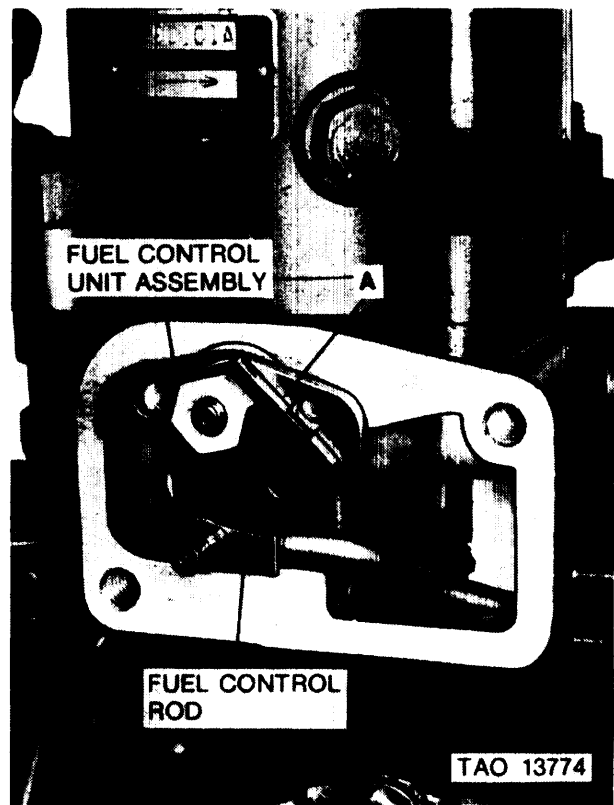

Figure 3-149. Correct installation of control unit in plunger sleeve dot.

c. Refer to figure 3-150. Align the control rod end with the hole in the control unit lever (A) and install retaining pin (B) as shown. Refer to figure 3-151, Install control unit retainer (A) and secure with two assembled washer screws (B). Torque tighten screws to 18-23 inch-pounds. Clearance between retainer and control unit shaft must be .0100 to .0250 inches. Secure screws with locking wire (C).

NOTE

Operate fuel control lever back and forth while looking through the overflow valve discharge hole in the hydraulic head. If the plunger sleeve is moving, the sleeve pin has remained properly engaged in the plunger sleeve slot.

NOTE

If the injection pump is to be tested after assembly, do not tighten the overflow valve or plastic tubing until the fuel leakage and timing check as described in paragraphs 3-50 through 3-58 has been performed.

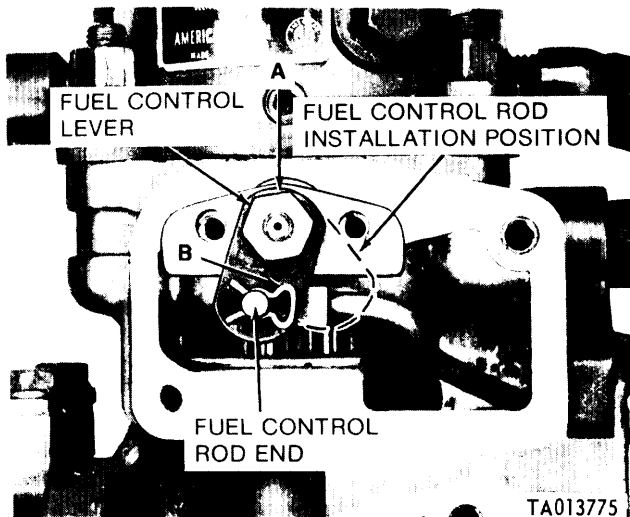

Figure 3-150. Installing fuel control unit assembly on metering and distributing fuel injection pump.

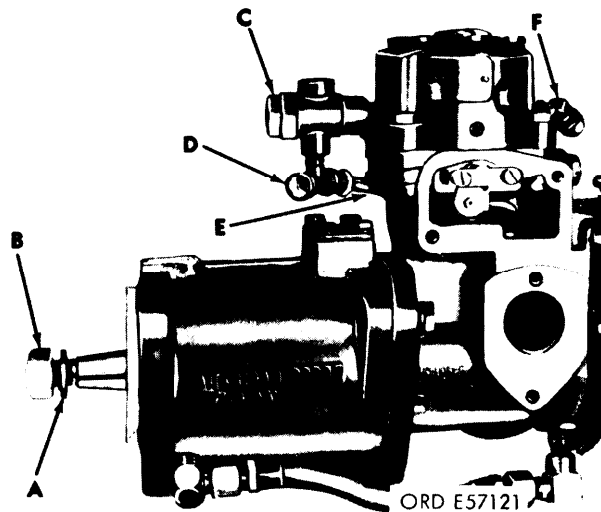

Figure 3-152. Installing overflow valve assembly

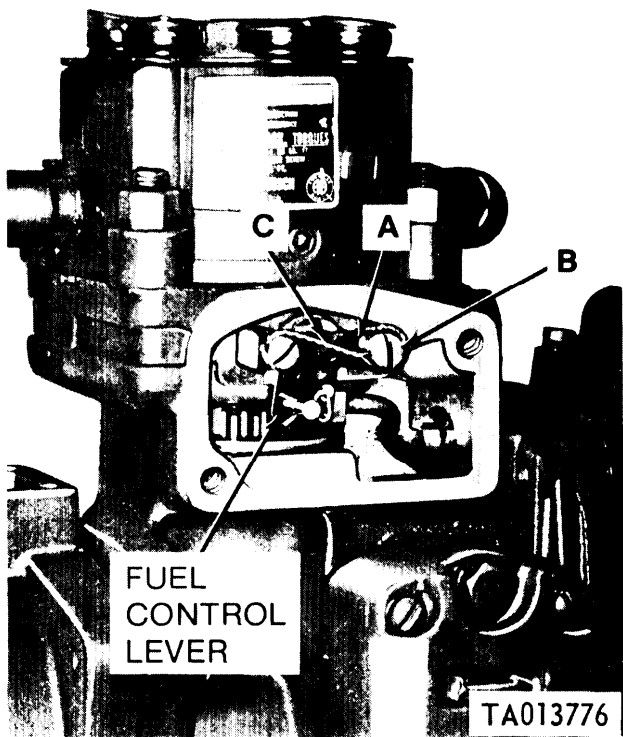

Figure 3-151. Installing control unit retainer.

3-45. Installation of Overflow Valve Assembly. a. General. Refer to figures 3-38, 3-39 or 3-40 for selection of the proper overflow valve assembly.

b. Installation. Refer to figure 3-152. Install lockwasher (A) and stet nut (B) on advance unit shaft. Tighten nut finger tight. Install overflow valve assembly (C) in position on hydraulic head.

3-46. Installation of Fuel Density Compensator. a. Installation of Fuel Density Compensator (Code B, C, D, E and F pumps). Refer to figure 3-153. Position a new mounting gasket (G) on governor housing. Position fuel density compensator on governor housing and secure with four 1/4 x 1 1/4 capscrews (E) and four 1/4 inch lockwashers (F). Torque tighten screws 50-60 inch-pounds. Install density compensator to overflow valve tubing (E, fig. 3-152). Connect tubing (A) to elbow (C). Install tubing (H) to tee (D) and elbow in hydraulic head (B).

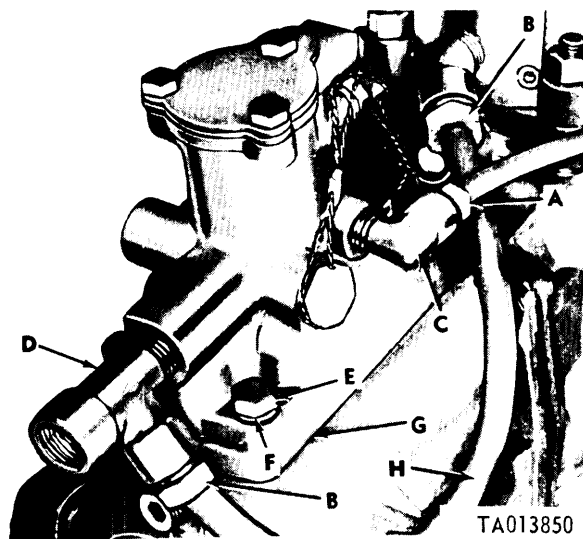

Figure 3-153. Installing fuel density compensator assembly.

CAUTION

Care should be exercised during installation of the compensator on code A pumps. The top of the fuel control link is not secure to the piston shaft (fig. 3-154). If the top of the link does not remain engaged in the shaft, the stop plate will fall into the governor housing, causing serious damage to the pump.

b. *Installation of Fuel Density Compensator (Code A Pumps).* Refer to figure 3-155, Position a new mounting gasket (A) on governor housing. Engage dovetail in torque link stop (B) with dovetails on guide (C) and compensator plate (D). All divetails must be properly engaged. Refer to a above and figure 3-153 to complete installation of compensator on injection pump.

NOTE

The stop furnished with a compensator is to be used with the compensator.

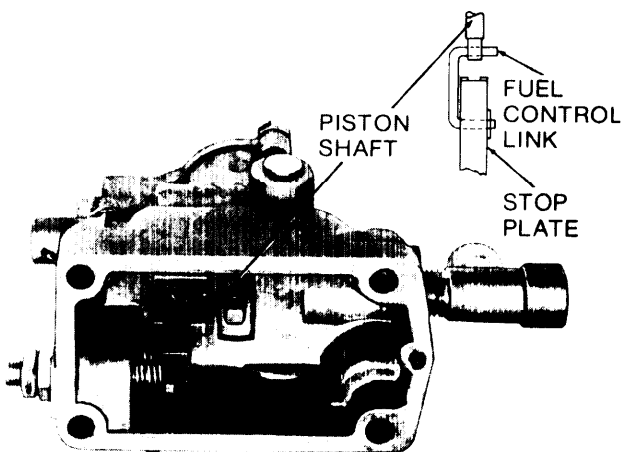

BOTTOM VIEW OF FUEL DENSITY COMPENSATOR

TA013777

Figure 3-154. installing stop plate and link assembly (Code A pumps).

c. *Tamper Proof Cover.* Do not install tamper proof covers. They will be installed after test and adjustment of pump in paragraphs 3-50 through 3-58.

d. *Installation of Stop Plate and Bridge Assembly and Governor Housing Cover (code G pumps).*

(1) Refer to figure 3-156. Install plate and bridge assembly (A) on governor housing and secure with two capscrews (B), lockwashers (C), and flat washers (D). Torque tighten screws to 50-60 inch-pounds.

NOTE

The plate and bridge assembly is installed over the rear pair of tapped holes in the governor housing.

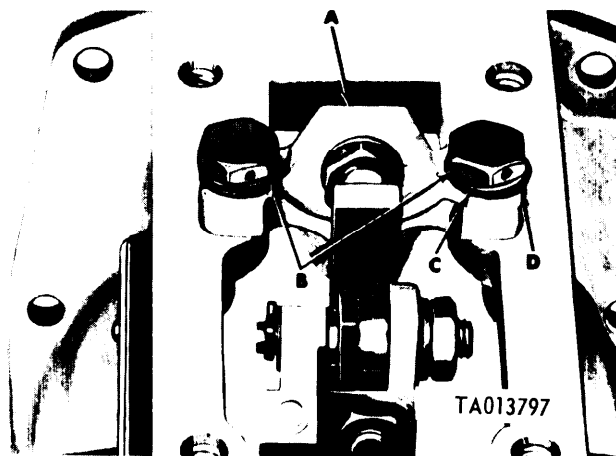

Figure 3-156. Installing plate and bridge assembly on governor housing (code G pumps).

(2) Refer to figure 3-157. With throttle lever secured in full fuel position, insert a feeler gage (A) between the stop plate (B) and smoke limit cam (C) and adjust locknuts (D) of droop plate screw to obtain a preliminary adjustment clearance of 0.020-inch.

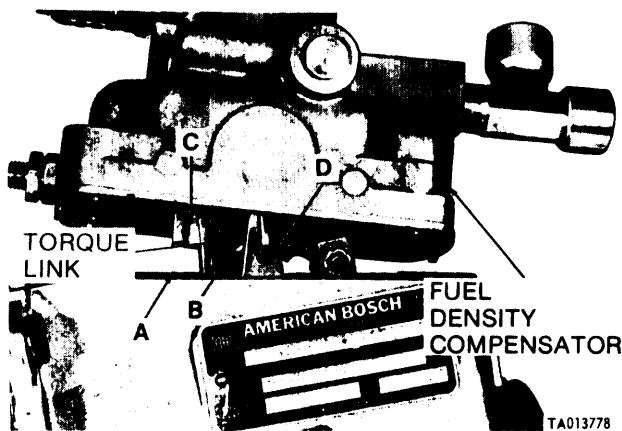

Figure 3-155. Assembling fuel density compensator fuel stop plates (Code A pumps).

NOTE

If the injection pump is to be tested after assembly, do not tighten the timing window screws until the fuel leakage and timing check as described in paragraphs 3-50 through 3-58 has been performed.

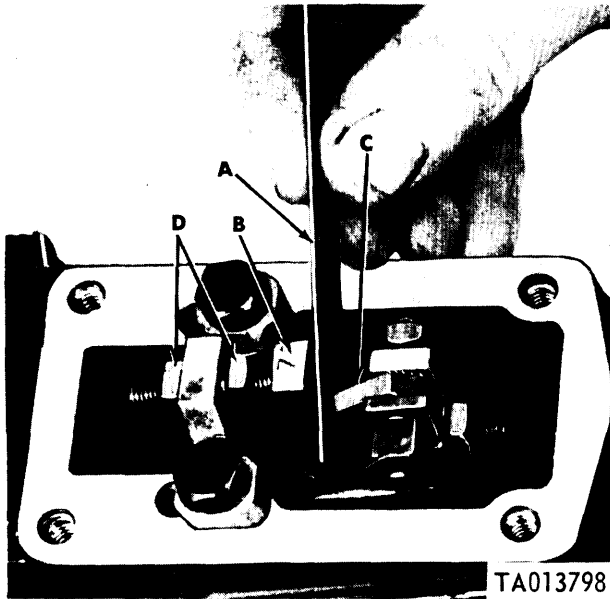

Figure 3-157. Checking stop plate and smoke limit cam clearance (code G pumps).

(3) Refer to figure 3-158. Install governor cover gasket (A) and governor cover (B). Secure cover with four machine screws (C) and lockwashers (D). Torque tighten screws to 50-60 inch-pounds.

NOTE

If the fuel pump is to be tested immediately after assembly, the governor cover should not be secured until adjustments are made as described in paragraphs 3-50 through 3-58.

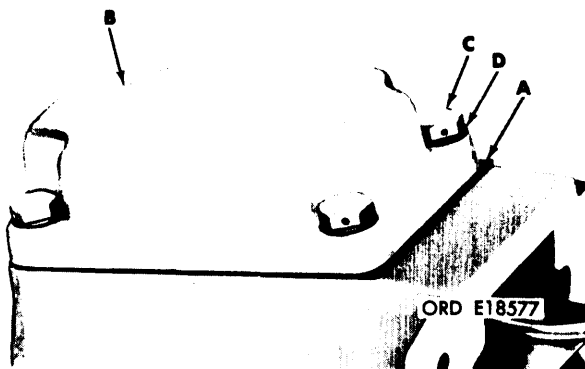

Figure 3-158. Installing governor cover (code G pumps).
3-47. Installation of Timing Window Cover and Fuel Shutoff Rod Assembly or Solenoid Assembly. a. *Assembly.* The timing window cover and fuel shutoff rod assembly were assembled during repair (paras. 3-21 and 3-22).

b. *Installation.* Refer to figure 3-159. Coat gasket (A) with a thin coat of sealer, MIL-S-45180 or equivalent on side facing cover. Install gasket (A), timing window cover and fuel shutoff rod assembly (B). Install two fillister head screws (C) and lockwashers (D).

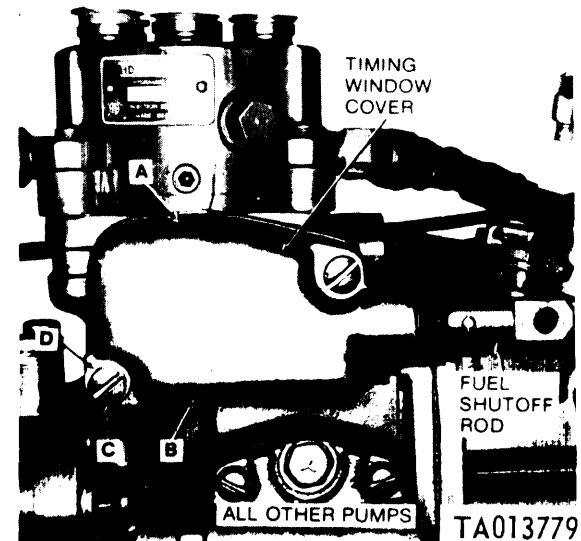
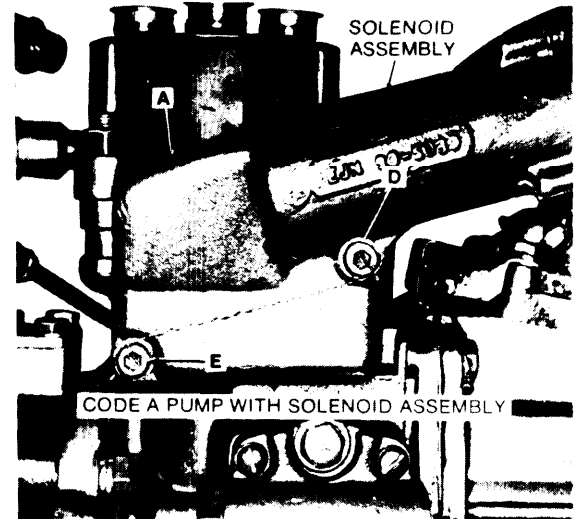

Figure 3-159. Installing timing window cover and fuel shutoff rod assembly or solenoid assembly.

Installation of Fuel Shutoff Solenoid Assembly. Install fuel shutoff solenoid assembly the same as in b above except use two socket head screws and lockwashers (E). Do not tighten screws and install wire until after pump is tested.

NOTE

Gasket - 11662856 (0.020 thick) is a service replacement for gasket - 7748841 (0.031 thick) and can be used with timing window cover on any pump, but is a mandatory replacement with the solenoid assembly on code A injection pump.

3-48. Installation of Fuel Supply Pump. *a. General.* Refer to paragraph 3-20a for selection of the proper fuel supply pump.

b. Installation. Refer to figure 3-160 for selection of the proper fuel supply pump and install necessary

fittings. Install the fuel supply pump as follows: Refer to figure 3-161. Install fuel supply pump gasket (A) and pump assembly (B) using two capscrews (C) and lockwashers (D).

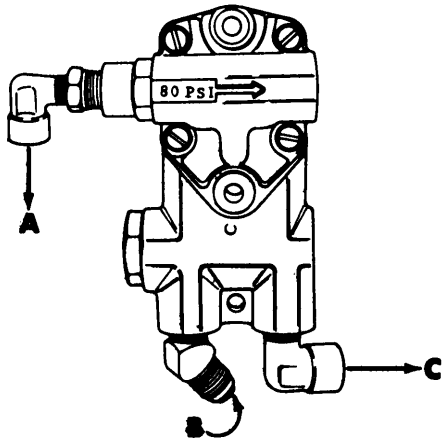

CODE A PUMPS

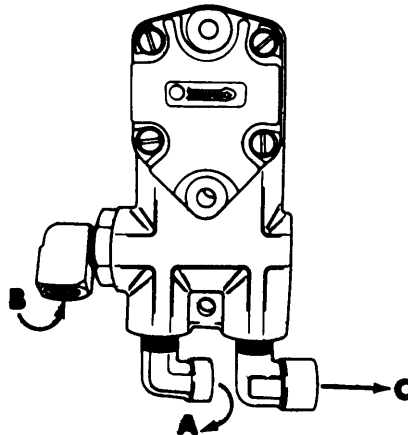

CODE B PUMPS

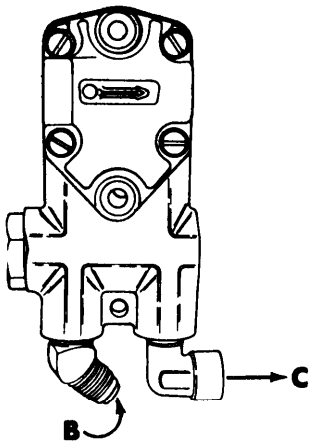

CODE G PUMPS

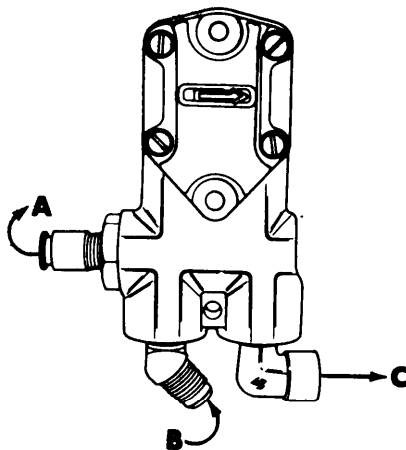

CODE C, D AND E PUMPS

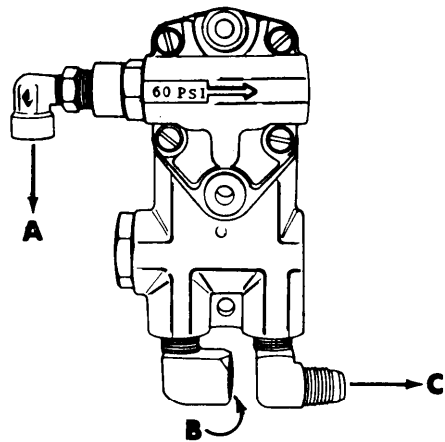

CODE F PUMPS

FUEL FLOW CODE

- A - FLAME HEATER FUEL OUTLET
- B - FUEL IN FROM VEHICLE
- C - TO ENGINE FUEL FILTER

TA013781

Figure 3-160. Installing proper fittings in fuel supply pump.

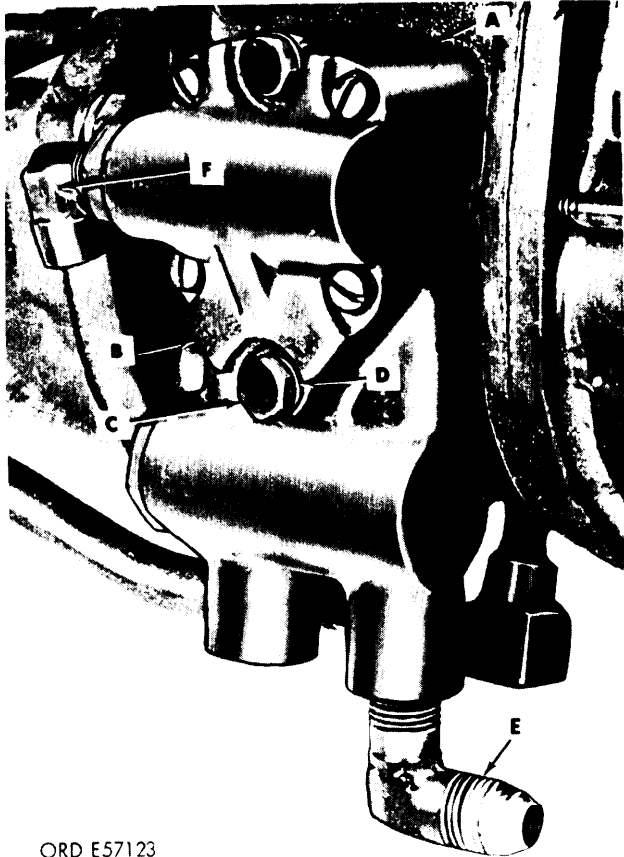

ORD E57123

Figure 3-161. Installing fuel supply pump assembly.

3-49 Metering and Distributing Pump Conversions. Recommended Pump conversions are permissible only if parts for replacement are not available. Parts removed or replaced should be appropriately tagged and returned to stock.

Section V. TESTS AND ADJUSTMENTS

3-50. General. *a.* The metering and distributing fuel injection pump with density compensator must be tested and adjusted on a fuel pump tester. For identification of this tester, its connections and

controls, refer to figure 3-162. Detailed description and operation instructions of the fuel injector pump tester (test stand) are provided in TM 9-4910-387-12, which accompanies the stand.

KEY to fig. 3-162

- A Fuel pressure gage (supply pump outlet).**
- B Fuel temperature gage**
- C Lube oil temperature gage**
- D Lube oil pressure gage**
- E Fuel dumping lever**
- F Fuel burette**
- G Tachometer**
- H Manifold vacuum- pressure gage**
- J Manifold pressure regulator**
- K Vacuum-pressure selector valve**
- L Manifold inlet**
- M Test nozzle accumulator chambers**
- N Counting light**
- P 24 Button**
- Q Fuel heat light**
- R Fuel heat switch**
- S Speed shifting crank**
- T Lube heat switch**
- U Lube heat light**
- V 500-100-OFF count switch**
- W Start count button**
- X Drive motor fast button**
- Y Drive motor slow button**
- Z Power ON light**
- AA Auxiliary motor switch**
- BB Manifold heat light**
- CC FORWARD-OFF-REVERSE switch**
- DD Drive motor stop button**
- EE Drive motor start button**
- FF Panel fuel pressure fitting**
- GG Fuel pressure gage (supply pump inlet)**
- HH Fuel pressure regulator**
- JJ Lube oil pressure regulator**
- K Test stand pump drive coupling**

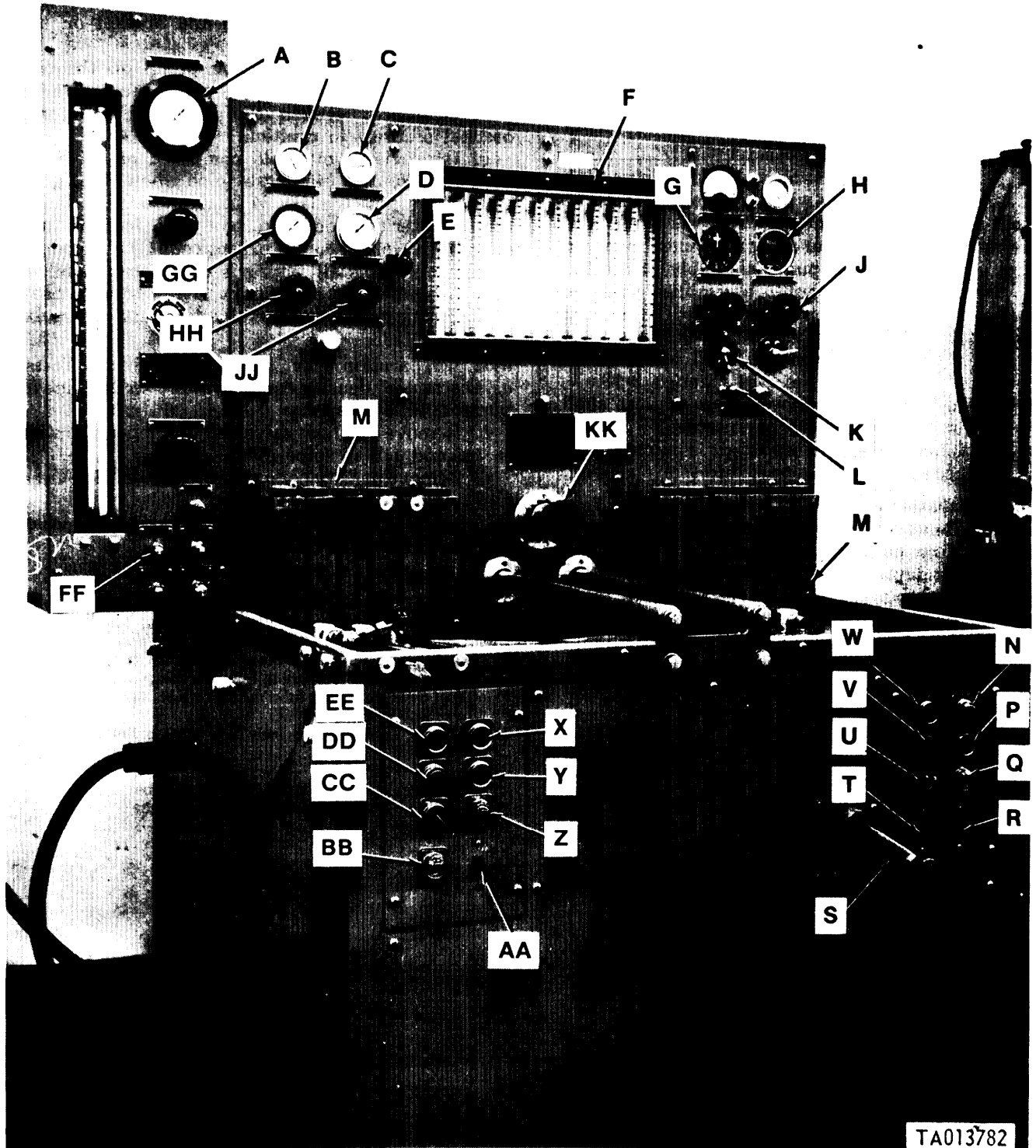

Figure 3-162. Fuel injection pump tester, left front view.

b. Table 3-3 lists the components of a typical kit which accompanies the fuel injection pump test stand.

c. Each step of metering and distributing fuel injection pump tests must be performed in the order

listed in tables 3-4 through 3-7. Successful calibration of the fuel injection pump can be accomplished by rigid adherence to the given instructions.

Table 3-3. Typical Test Stand Accessory Kit

Qty	Part no.	Description
1	11020392	Adapter bracket
1	11020384	Pump hub
1	11020376	Adapter ring assembly
6		Fuel delivery tube assemblies
6		Nozzle and adapter holders (2 holes)
1		Transparent dust cover

d. All fuel injection pump assemblies, including fuel density compensator where applicable, shall be tested and adjusted on the fuel metering and distributing pump test stand prior to assembly on an engine or returning the pump assembly to stock.

e. Depot overhauled pump assemblies shall be tested in accordance with paragraphs 3-51, 3-57, and 3-58.

f. Repaired pump assemblies shall be tested in accordance with paragraphs 3-51 through 3-58.

g. Pump assemblies removed from engines shall be tested in accordance with paragraphs 3-51, 3-57, and 3-58 to determine if pump repair is necessary. If repair is necessary, follow procedures in f above.

3-51. Installation of Fuel Injection Pump on Test Stand. a. Remove the fuel injection pump drive gear and hub (if on pump to be tested).

b. Install adapter ring, Part No. 11020376, on the fuel injection pump. Torque tighten the three mounting bolts to 27-35 foot-pounds.

c. Install fuel injection pump and adapter ring on the test stand adapter bracket, Part No. 11020392. Torque tighten the four mounting bolts to 27-35 foot-pounds.

d. Lubricate the adapter ring oil seal and install the test stand pump hub, Part No. 11020384, and Woodruff key on the injection pump shaft and secure with retaining nut and lockwasher. Torque tighten nut to 65-70 foot-pounds.

NOTE

Do not remove any elbows or fittings from the pump. Fabricate necessary connections

and fittings to install pump on the test stand.

e. Lubricate the test stand rails with test oil and place the fuel injection pump and bracket on the rails.

f. Position the fuel injection pump on the test stand drive coupling allowing a minimum of 1/16 inch clearance between the hubs. Clamp pump bracket securely in position.

g. Improvise a manifold composed of a 3/8 in. flare tube to 1/4 in. 45-degree pipe elbow (G, fig. 3-163), 1/4 in. pipe tee (H), 1/4 in. pipe to 1/2 in. flared tube adapter (J), and 1/4 in. pipe to 1/4 in. flare tube adapter (K) (on all pumps except code G). On code G pumps only, install improvised adapter manifold into hydraulic head inlet fitting after hydraulic head port closing test, delivery valve test, and hydraulic head leak test.

3-52. Preparation for Hydraulic Head Tests.

a. Disconnect density compensator overflow line at pump overflow valve.

b. Remove overflow valve and plug openings with 1/4 in. and 1/8 in. pipe plugs.

c. Remove density compensator to hydraulic head fuel line.

d. Position the nozzle tester on the right corner of the test stand (fig. 3-164).

KEY to fig. 3-163

- A Test stand fuel pressure to supply pump inlet hose
- B Supply pump outlet to compensator inlet hose
- C Compensator inlet tee to pressure gage hose
- D Overflow valve to test stand fuel return hose
- E Test stand lube pressure to fuel injection pump hose
- F Fuel injection pump lube return to test stand lube return hose
- G Elbow, 45-degree, 3/8 inch flare tube to 1/4 inch pipe
- H Tee, 1/4 inch pipe
- J Adapter, 1/4 inch pipe to 1/2 inch flare tube
- K Adapter, 1/4 inch pipe to 1/4 inch flare tube

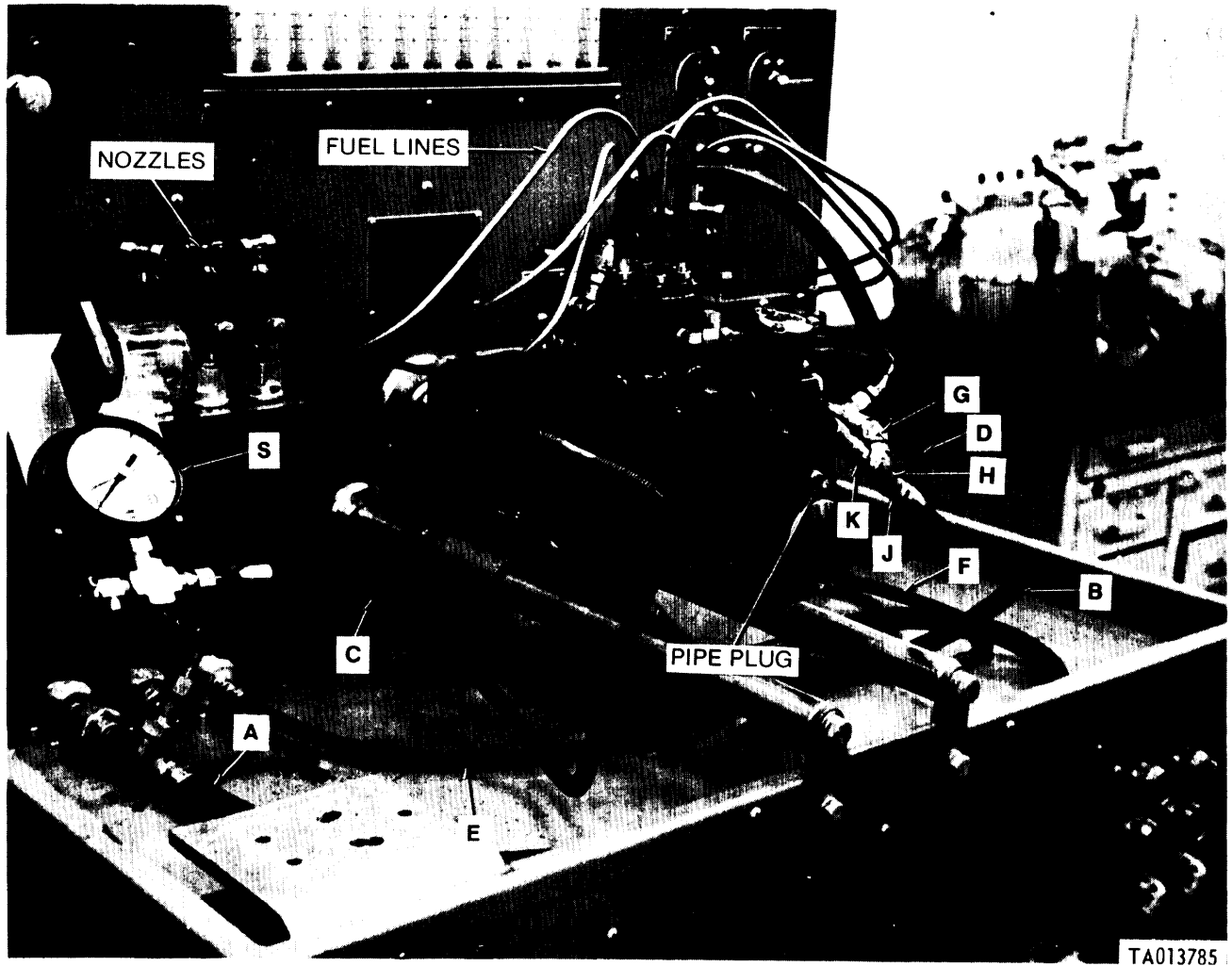

Figure 3-163. Fuel injection pump installed on test stand, left side.

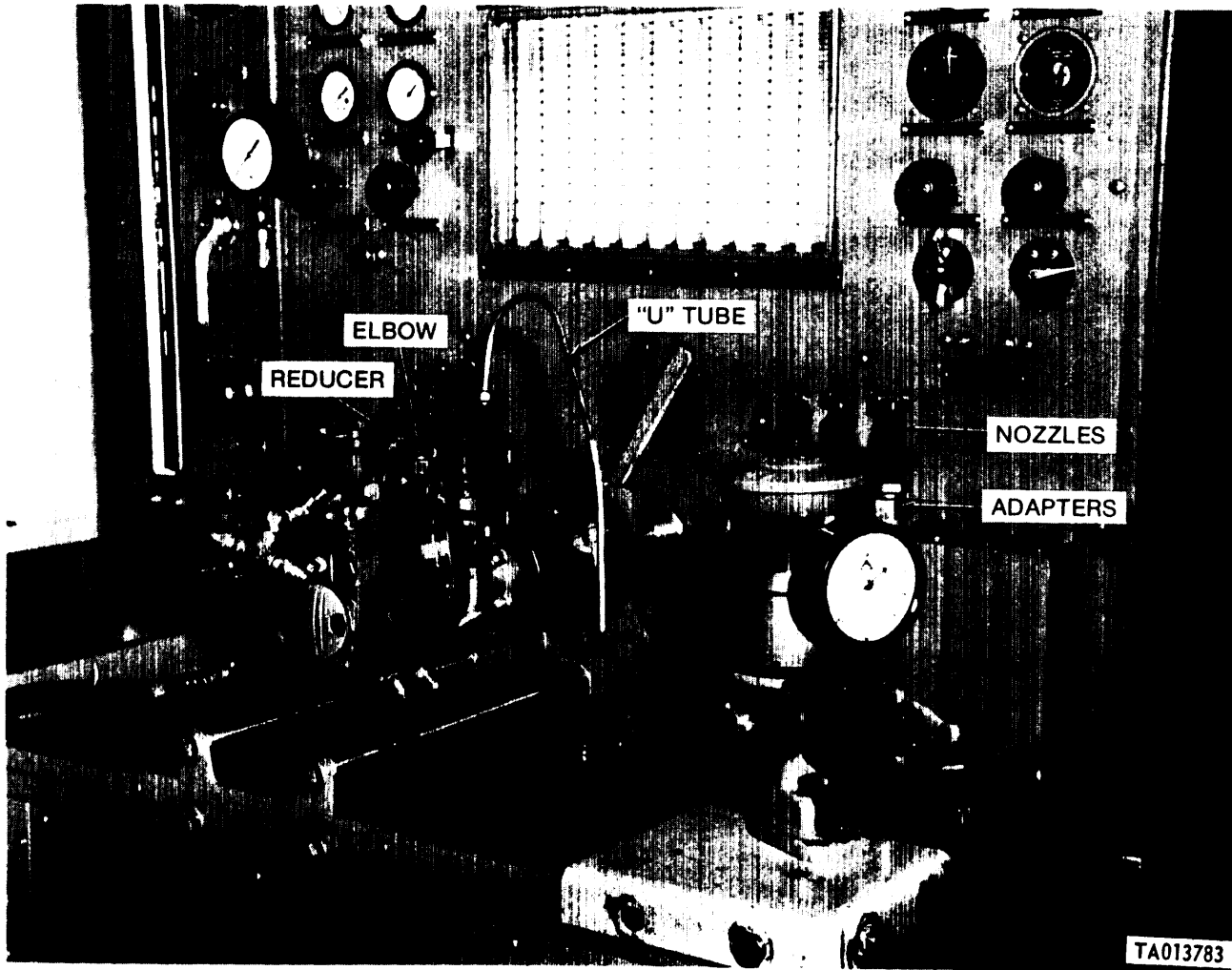

Figure 3-164. Fuel injection pump on test stand showing nozzle tester hook-up.

e. Improvise a manifold composed of a 3/8 in. flare tube to 1/4 in. pipe 45-degree elbow (A, fig. 3-165), a 1/4 in. pipe coupling (B), and a 1/4 in. pipe to 1/4 in. flare tube adapter (C).

- A Elbow, 45-degree, 3/8 in. flare tube to 1/4 in. pipe
- B Coupling, 1/4 in. pipe
- C Adapter, 1/4 in. pipe to 1/4 in. flare tube

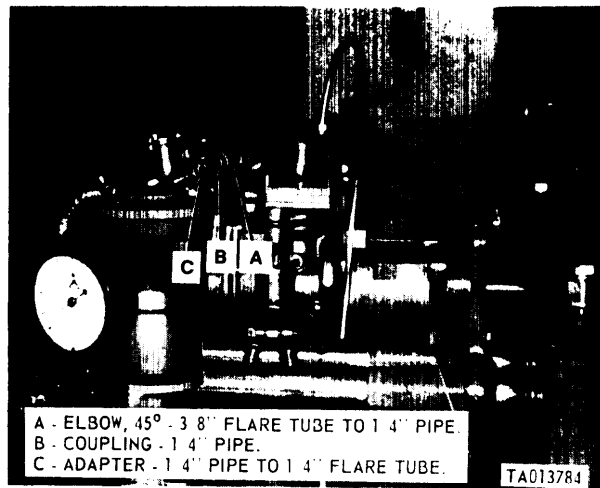

Figure 7-165. Fuel injection pump on test stand showing improvised manifold for nozzle tester.

f. Connect outlet of the nozzle tester to the improvised adapter using a high pressure hose.

g. Install locally fabricated U tube in the No. 1 hydraulic head outlet. Position a plastic container under the open end of the U tube to collect test oil (which will be returned to the tester reservoir) (fig. 3-164).

h. Remove timing device cover and timing window cover, or fuel shutoff housing.

3-53. Hydraulic Head Port Closing Test. a. Secure the throttle lever in the full fuel position with a spring or other suitable device (fig. 3-163).

b. Remove delivery valve screw (A, fig. 3-166) and delivery valve spring (B). Reinstall delivery valve screw.

NOTE

Delivery valve is matched to the hydraulic head. Do not replace or interchange valve.

c. Apply 3-10 psi test oil pressure to the hydraulic head with the nozzle tester. Loosen the ¼ in. pipe plug in the hydraulic head overflow valve opening to bleed air from the head. Tighten plug.

d. Rotate the test stand drive coupling clockwise (as viewed from the drive end) with the test stand spanner wrench until the slotted, red painted tooth is visible in the timing window on the pump housing (fig. 3-167).

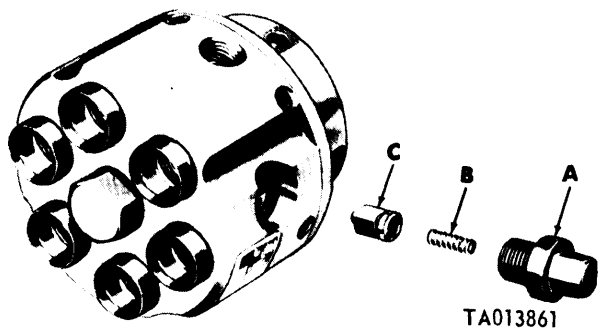

- A Delivery valve screw
- B Delivery valve spring
- C Fuel delivery valve

Figure 3-166. Installing fuel delivery valve and screw.

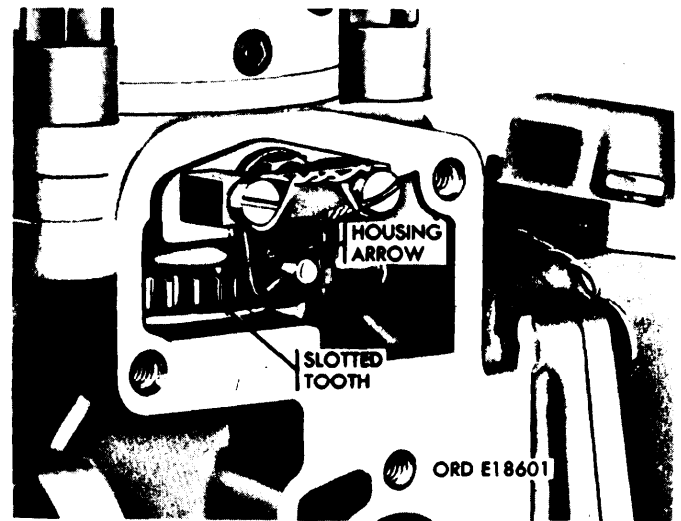

Figure 3-167. Alining slotted tooth with arrow on housing.

NOTE

The scribed mark on the advance unit hub should not be alined with its pointer,

e. Slowly continue to rotate the drive hub in a clockwise direction (as viewed from the drive end) until the test oil begins to form droplets at the end of the U-tube. Slowly continue to rotate the drive hub until the test oil flows freely and then diminishes and stops. This is port closing. The scribed mark on the advance unit hub should now be alined with the pointer (fig. 3-168) and the slotted, red painted tooth in the timing window should be one tooth to the right of the mark on the pump housing. If the above specification is not met, the hydraulic head, tappet assembly and/or camshaft must be replaced. If the plunger button is damaged, hydraulic head must be replaced.

f. Install the timing device cover using a new gasket, and tighten the retaining bolts and lock-washers fingertight. Install timing window cover or fuel shutoff housing. Remove U-tube from hydraulic head (fig. 3-164). Remove delivery valve screw (A, fig. 3-166). Remove fuel delivery valve (C), and

manually work the valve in the bore. Valve must be free with no sticking or binding. If valve does not operate freely, replace the hydraulic head assembly.

g. Install valve (C), delivery valve spring (B), and screw (A), and torque tighten valve screw to 40-45 foot-pounds. Loosen screw and retorquer to 40-45 foot-pounds two more times.

3-54. Delivery Valve Test. a. Rotate the drive coupling in a counterclockwise direction until the slotted, red painted tooth is one-half tooth to the right of the mark on the pump housing.

b. Slowly actuate the nozzle tester and note the reading on the nozzle tester gages as the delivery valve opens. This will be evidenced by a sudden drop in pressure. The delivery valve should open between 250 and 400 psig.

NOTE

Do not exceed 425 psig as damage to preformed packings may result.

c. If the reading is not within specification, remove the delivery valve and inspect the spring, valve, and seat for foreign matter or damaged parts (fig. 3-166). If spring is defective, replace spring. If valve or seat is defective, replace the hydraulic head assembly.

3-55. Hydraulic Head Leak Test. a. Remove timing device cover, timing window cover or fuel shutoff housing. Rotate the drive coupling in a clockwise direction until the mark on the advance unit hub is alined with the pointer (port closing) (fig. 3-168).

Table 3-4. Calibration of LDT-465-1C (Code E Pump)

Use two hole injector nozzles only.
 Set smoke limit torque cam angle to 48°.
 cc/500 Strokes, Diesel Fuel 0.81-0.83 Sp. Gr. at 60° F.
 Calibration limits ± 1 cc/500 strokes.

Sequence of calibration	1	2	3	4	5	6	7
Fuel temp. range degrees F.	2850 rpm high idle	1500 rpm full load	2600 rpm full load (ref. only)	2940 rpm fuel shut-off	1200 rpm droop screw	700 rpm low idle	150 rpm
		Diesel Fuel, 0.81-0.83 Sp. Gr. at 60 degrees F.					
60-105	25	38	37-34	5 cc or less.	37	12	30
105-150	25	37	36-33	5 cc or less.	35	12	30
150° F. controlled.	21	34	Gulf 45A Fluid. 33-31	5 cc or less.	33	8	30

After calibration, recheck 2600 rpm full load. If outside limits, repeat entire sequence.
 If the 2600 rpm flow does not fall within reference limit, change smoke limit cam angle 5° and repeat test.
 Increase cam angle if 2600 rpm flow is high.
 Decrease cam angle if 2600 rpm flow is low.
 If fuel flow cannot be adjusted to these limits, check engagement of compensator stop plate and linkage, and angular position of smoke limit cam. Final high and low idle adjustments may be made on an operating engine.

Table 3-5. Calibration of LD-465-1, LD-465-1C and LDS-427-2 (Code C, D, and G Pumps)

Use two hole injector nozzle only.
 Set smoke limit torque cam angle: 75° — LD-465-1 and 1C (code C and D pumps)
 65° — LDS-427-2 (code G pumps)
 cc/500 Strokes, Diesel Fuel 0.81-0.83 Sp. Gr. at 60° F.
 Calibration limits ±1 cc/500 strokes.

Sequence of calibration	1	2	3	4	5	6
fuel temperature NFW Degrees F.	2850 rpm high idle	2600 rpm full load Main fuel stop rate	2940 rpm fuel shut-off	1400 rpm reference do not adjust	700 rpm low idle	150 rpm
60-105	25	38	5 cc or less.	43	12	30
105-150	25	37	5 cc or less. Gulf 45A Fluid	41	12	30
150° F. controlled	21	34	5 cc or less.	39	8	30

After calibration, recheck 2600 rpm full load. If outside limits, repeat entire sequence.

Special Instruction: LDS-427-2 (Code G Pump), only after calibration, set droop screw to 38 cc/500 strokes at 1000 rpm.

If fuel flow cannot be adjusted to these limits, check engagement of compensator stop plate and linkage, and angular position of smoke limit torque cam. Final high and low idle adjustments may be made on an operating engine.

Table 3-6. Calibration of LDS-465-1 and LDS-465-1A (Code B and F Pumps)

Use 2-hole injector nozzle for LDS-465-1 (code F pumps)
 Use 1-hole injector nozzle for LDS-465-1A (code B pumps)
 Set smoke limit torque cam angle 100° F.
 cc/500 Strokes, Diesel Fuel 0.81-0.83 Sp. Gr. at 60° F.
 Calibration limits ±1 cc/500 strokes.

Sequence of calibration	1	2	3	4	5	6
Fuel, temperature range degrees F.	2850 rpm high idle	2600 rpm full load main fuel stop plate	2940 rpm fuel shut-off	1200 rpm full load droop screw	700 rp, low idle	150 rpm
60-105	25	45	5 cc or less.	49	12	30
105-150	25	44	5 cc or less. Gulf 45A fluid	47	12	30
150° F. controlled.	22	42	5 cc or less.	46	9	30

After calibration, recheck 2600 rpm full load. If outside limits, repeat complete sequence.

If fuel flow cannot be adjusted to these limits, check engagement of compensator stop plate and linkage, and angular position of smoke limit torque cam. Final high and low idle adjustments may be made on an operating engine.

Table 3-7 © Calibration of LDS-465-2 (Code A Pump)

Use 1-hole injector nozzle.
 Set smoke limit torque cam angle 70° ±
 cc/500 Strokes, Diesel Fuel 0.81-0.83 Sp. Gr. at 60° F.
 Calibration limits ± 1 cc/500 Strokes.

Sequence of calibration	1	2	3	4	5	6
Fuel temperature range degrees F	3100 rpm high idle	2800 rpm full load main fuel stop plate	3150 rpm fuel shut-off	1200 rpm full load droop screw	700 rpm low idle	150 rpm
60-150		50	5 cc or less.	49	12	30
105-150		49	5 cc or less. Gulf 45A fluid	47	12	30
150° F. controlled.		47	5 cc or less.	46	10	30

After calibration, recheck 2800 rpm full load. If outside limits, repeat complete sequence.
 If fuel flow cannot be adjusted to these limits, check engagement of compensator stop plate, torque link stop and guide, and angular position of smoke limit torque cam. Final low idle speed adjustment to be made on an operating engine. High-idle adjustment affects full-load fuel quantity. Do not adjust high idle except at time of pump calibration.
 Activate electric solenoid fuel shutoff by applying 24 v dc to solenoid electrical connection. Fuel should stop flowing immediately each time the solenoid is activated. If shutoff does not operate, replace solenoid. Check operating lever travel with template. 5120-134-7462.
 Template should be held flush against side of transfer pump with center line mark alined with shaft. Center line of lever to fall within lines indicated. If not within template limits, check governor spacers and springs, gaps and preloads, and operating lever to operating shaft position.

NOTE

The time given for test fluid at 80°F. Test fluid temperature above 80°F. will tend to reduce time, while test fluid temperatures below 80°F. will tend to increase the time for the pressure to drop to 250 psig.

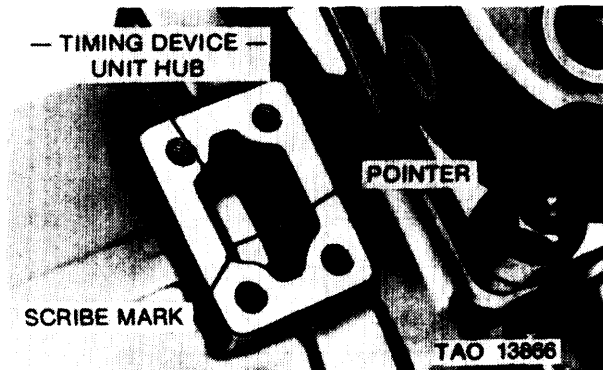

Figure 3-168. Aligning scribe mark on timing device hub with timing pointer.

b. Slowly actuate the nozzle tester until a pressure reading of 400 psig is attained.

NOTE

Do not exceed 425 psig as damage to pre-formed packings may result.

c. The pressure will drop slowly. When pressure drops to 350 psig, time the rate of pressure drop to 250 psig. If the time of pressure drop from 350 to 250 psig is less than 30 seconds, leakage is indicated.

Check for visible external leaks at connections, around the hydraulic head, fuel control unit shaft and plunger drive gear. If no visible external leakage is present, the leakage is internal. Presence of fuel as the fuel control unit indicates a worn fuel control unit shaft, or a damaged control unit packing. Install a new control unit packing (para 3-44) and repeat test. If leakage is still present, install a new fuel control unit (para 3-44). Fuel leakage in the area of the plunger drive gear, as observed through the timing window opening, indicates a damaged hydraulic head, lower ring packing or a worn fuel plunger. Install a new hydraulic head lower ring packing (Para 3-28) and repeat test. If leakage is still present, install a new hydraulic head assembly (para 3-40). An external leak at the bottom of the hydraulic head flange indicates a damaged hydraulic head upper ring packing. Install a new aulic head upper ring packing (para 3-28) and repeat test.

d. Install timing device cover and timing window cover or fuel shutoff housing.

3-56. Precalibration Adjustments. *a.* Remove nozzle tester hose and fittings from hydraulic head inlet elbow. Remove nozzle tester from test stand. Remove improvised adapter.

b. Remove fuel density compensator. On code G pumps only, remove governor cover.

c. Set the smoke limit torque cam angle in accordance with table 3-8. Smoke limit torque cam angle is the angle measured from the cam nose to the fulcrum lever (fig. 3-73).

d. Back out both idle speed screws, flush with the bottom of lug.

e. Remove the governor housing end cover, inner and outer governor springs and spacers. Remove the gasket and discard unless a new, untorqued gasket was used.

f. Position the operating lever in the low-idle position. Hold with a spring.

g. Using a depth micrometer, measure and record the distance between the governor housing and the governor sliding sleeve.

h. Position the operating lever in the full-fuel position. Hold with a spring.

i. Again using the depth micrometer, measure and record the distance between the governor housing and the sliding sleeve. A reading of 0.630 inch is required for full sliding sleeve travel. If specification is not attained, internal interference to the governor components or control sleeve is indicated.

j. Position the operating lever in the low-idle fuel position. Hold with a spring.

k. Install the outer spring spacers and outer spring on the governor gap gage, 4910-793-5040.

NOTE

Do not install the gasket since the gage is designed to compensate for gasket thickness.

l. Install the outer spring spacers and governor gap gage in the governor housing until the gage just touches the spring (fig. 3-144). Using feeler gages, measure the distance between the gage and the

governor housing. Add or remove spacers until the correct dimension in figure 3-144 is attained.

m. Remove the outer spring and spacer from the gage and install on the governor end cover.

n. Install the inner spring and spacer on the gage and install in the governor housing (fig. 3-145). With the gage flush with the governor housing, measure the distance between the inner spring spacer and the gage. Add or remove spacers until the correct dimension shown in figure 3-145 is attained.

o. Remove the inner spring and spacer from the gage and install on the governor end cover.

p. Using a new gasket, install the governor end cover, inner and outer springs and spacers in the governor housing. Torque bolts to 50-60 lb. in.

q. Reinstall fuel density compensator using new gasket. Torque the four ¼ inch bolts to 75-100 inch-pounds. Reinstall fuel line between fuel density compensator inlet tee and hydraulic head inlet. On code G pumps only, reinstall governor cover.

3-57. Preparation for Calibration.

NOTE

The key letters shown below in parentheses refer to figures 3-163, 3-169, and 3-170 unless otherwise indicated.

a. Remove the ¼ inch pipe plug from the hydraulic head outlet port and install the overflow valve. Remove socket head pipe plug from the rear of the governor housing (code A, B, E and F pumps).

b. Connect compensator to overflow valve tube assembly at the valve. Install tube assembly from compensator inlet tee to the elbow in the hydraulic head.

c. Install timing window cover, or solenoid housing assembly (para 3-47). Torque socket head capscrew securing the solenoid housing assembly to 110-120 inch-pounds. Install timing device cover, using a new gasket, and secure with retaining bolts and lockwashers.

d. Install test stand-to-pump hoses. Refer to figures 3-163, 3-169 and 3-170.

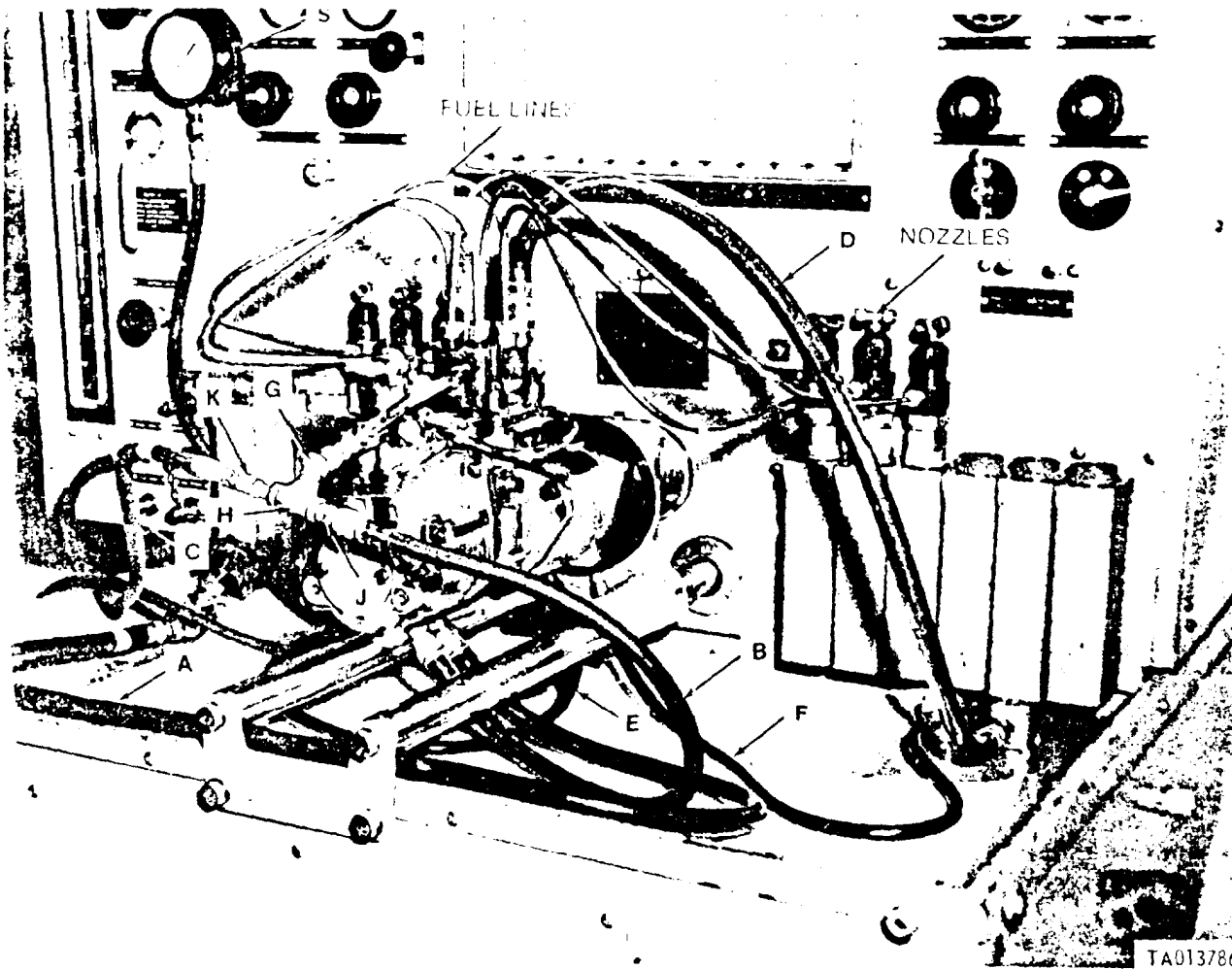

- A Test stand fuel pressure to supply pump inlet hose
- B Supply pump outlet to compensator inlet hose
- C Compensator inlet tee-to-pressure gage hose
- D Overflow valve-to-test stand fuel return hose
- E Test stand lube pressure-to-fuel injection pump hose
- F Fuel injection pump lube return-to-test stand lube return hose
- G Elbow. 45°. 3/8 inch flare tube to 1/4 inch pipe
- H Tee. 1/4 inch pipe
- J Adapter. 1/4 inch pipe to 1/2 inch flare tube
- K Adapter. 1/4 inch pipe to 1/4 inch flare tube

Figure 3-169. Fuel injection pump installed on test stand, right side

Table 3-8 Smoke Limit Torque Cam Angle

Pump Code	Engine Model	Cam Angle
A	LDS-465-2	70°
B, F	LDS-465-1A, LDS-465-1	100°
C, D	LD-465-1.LD-465-LC	75°
E	LDT-465-1C	48°
G	LDS-427-2	65°

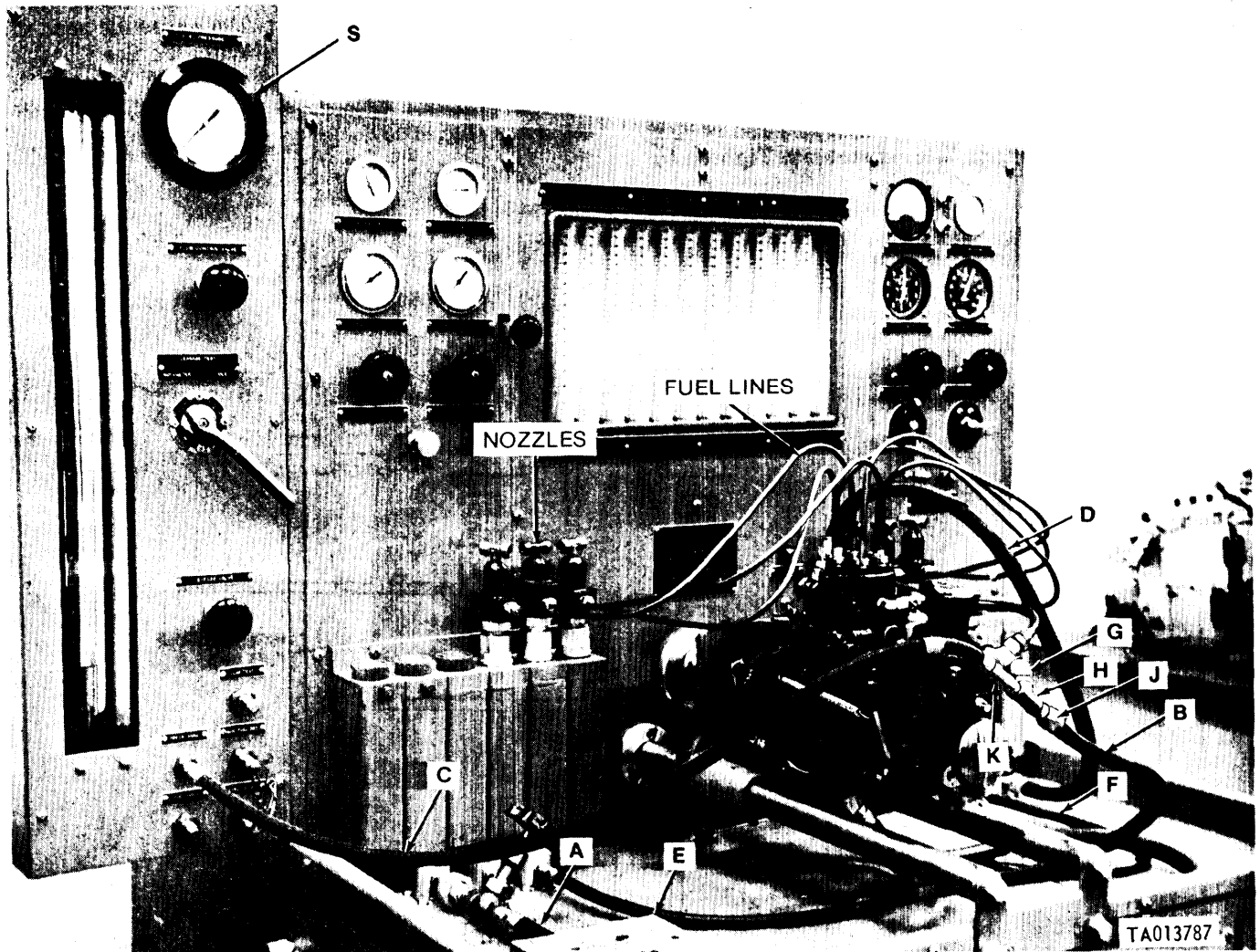

- A Test stand fuel pressure-to-supply pump inlet hose
- B Supply pump outlet-to-compensator inlet hose
- C Compensator inlet tee-to-pressure gage hose
- D Overflow valve-to-test stand fuel return hose
- E Test stand lube pressure-to-fuel injection pump hose
- F Fuel injection pump lube return-to-test stand lube return hose
- G Elbow, 45°, 3/8 inch flare tube-to-1/4 inch pipe
- H Tee, 1/4 inch pipe
- J Adapter, 1/4 inch pipe-to-1/2 inch flare tube
- K Adapter, 1/4 inch pipe-to-1/4 inch flare tube

Figure 3-170. Fuel injection pump installed on test stand using panel, part No. 11020519.

(1) Connect the test stand lube pressure-to-fuel injection pump hose (E) to the fuel injection pump oil inlet fitting in the advance unit housing.

(2) Connect the fuel injection pump lube return-to-test stand lube return hose (F) to the test stand lube oil return.

(3) Connect the test stand fuel pressure-to-supply pump inlet hose (A) to the inlet port of the fuel injection pump fuel supply pump.

(4) Connect the fuel injection pump fuel supply outlet-to-compensator inlet hose (B) to the adapter

(J) at the compensator inlet tee (H) (on all except code G pumps).

(5) Connect the compensator inlet tee-to-pressure gage hose (C) to the fuel gage (fig. 3-163 and 3-169) or to the pressure gage connection of the test stand panel (fig. 3-170) (all except code G). On code G pumps, install improvised manifold consisting of elbow (G), tee (H), and adapters (J) and (K) into the elbow of the hydraulic head inlet, and connect hoses.

(6) Connect the test stand overflow valve-to-test stand fuel return hose (D) to the injection pump overflow valve. Plug unused opening in tee of overflow valve to prevent loss of test fluid.

e. Install nozzle and adapter holders in the accumulator chambers, three on each side of center drive hub (refer to fire 3-164).

f. Install previously calibrated nozzle and holder assemblies in the accumulator chambers. Tighten to

prevent leakage. (Refer to tables 3-4 through 3-7 for proper nozzles to be used.)

g. Install six fuel delivery tube assemblies supplied with the test stand, to the hydraulic head in correct numbered sequence. (Hydraulic head outlet ports are numbered.) Connect the other end to the injector nozzle assemblies in correct number sequence (fig. 3.171).

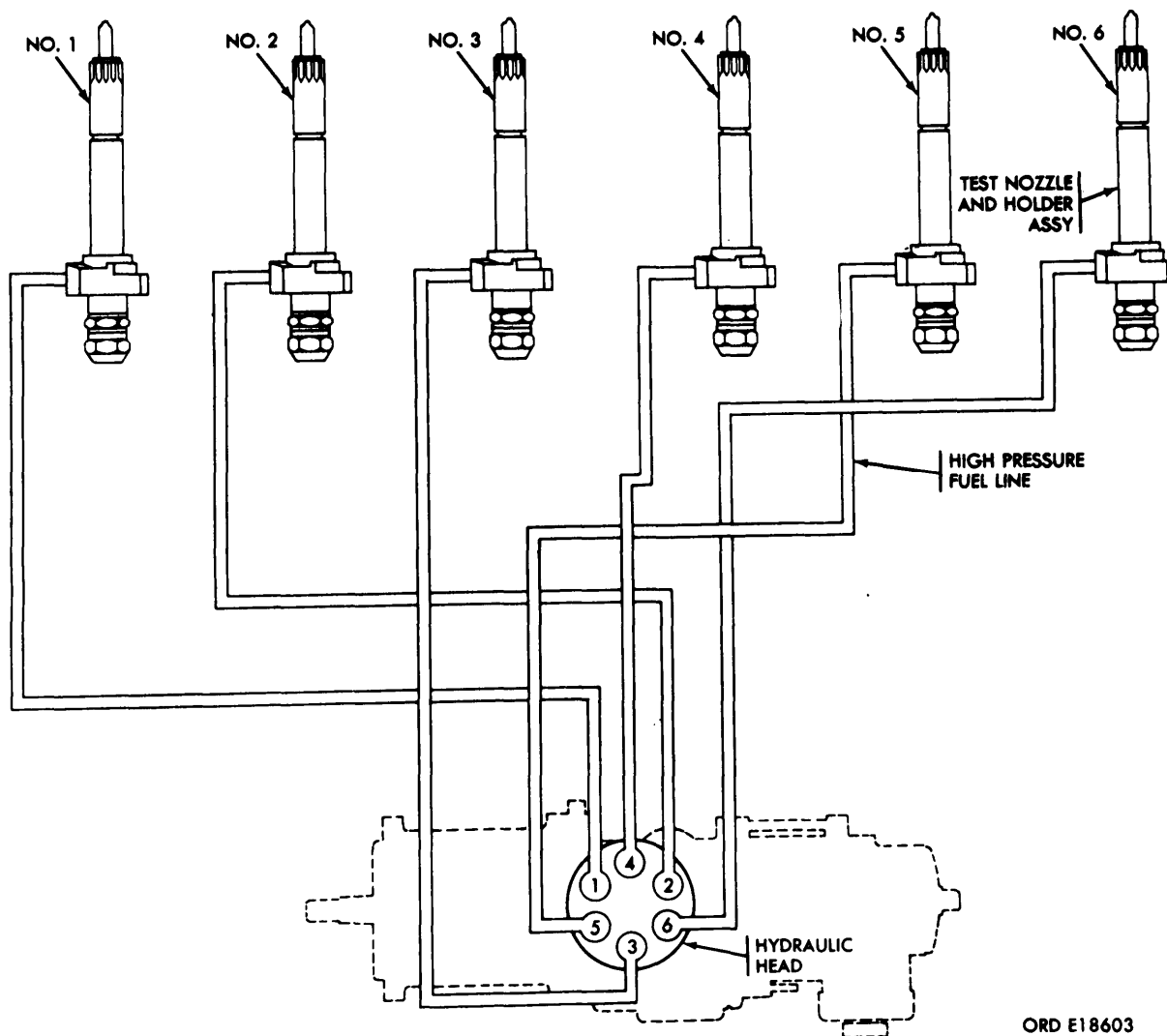

ORD E18603

Figure 3-171. Metering and distributing pump discharge sequence.

3-58. Calibration of Fuel Injection Pump. a.

General. The following conditions must be maintained during pump calibration:

(1) Fuel pressure in fuel pressure gage (GG, fig. 3-162) must be 3-5 psi, all speeds.

(2) Fuel return pressure after overflow valve, 5 psi maximum.

(3) Lubricating oil on the lube oil pressure gage (D, fig. 3-162), 35 psi minimum.

(4) Do not calibrate pump with diesel fuel heavier than 0.83 specific gravity at 60 degrees F.

Heavy and light fuels may be blended to obtain proper specific gravity. (See table 3-9 for specific gravity temperature conversion.)

(5) Final high- and low-idle adjustment to be made on operating engine. (Except on code A pump, adjust low-idle only.)

b. Pre-calibration Procedures.

NOTE

The key letters shown below in parentheses refer to figure 3-162 unless otherwise indicated.

(1) All new fuel injection pump assemblies from stock, as well as service and repaired pumps must be calibrated on a test stand, using calibration limits tables 3-4 through 3-7, before installation on an engine.

(2) The fuel injection pump must be completely assembled for this test. Fuel density compensator assemblies may be new, functionally checked in accordance with paragraph 3-24.

(3) Push the test stand 24-volt button (P). The power ON light (Z) should glow. Turn the auxiliary motor switch (AA) to the ON position.

(4) Turn on the lube heat switch (T) to bring oil to 150° on the lube oil temperature gage (C).

(5) Adjust the lube oil regulator (JJ) to obtain an oil pressure of 35-45 psi on lube oil pressure gage (D). Assure adequate drainage to prevent flooding pump internally.

Table 3-9. Temperature of Specific Gravity Conversion

Temperature in degrees F.	Specific gravity
60	0.810-0.830
65	0.808-0.828
70	0.806-0.826
75	0.804-0.824
80	0.802-0.822
85	0.800-0.820
90	0.798-0.818
95	0.797-0.816
100	0.795-0.815
105	0.793-0.813
110	0.791-0.811
115	0.789-0.809
120	0.787-0.807
125	0.785-0.805
130	0.783-0.803

NOTE
Hydrometer, 6630.350-9431 is available.

(6) Turn on the fuel heat switch (R) to bring fuel temperature within range listed on calibration tables. Check temperature on gage (B).

(7) Open suction valve of fuel supply hose (A, fig. 3-163); and adjust fuel regulator (HH) to obtain 3-5 psi on gage (GG) at supply pump inlet.

(8) Set 500-1000-OFF count switch (V) at 1000, the FORWARD-OFF-REVERSE switch (CC) at the REVERSE position, and the test stand speed shifting crank (S) at "High Range" position. Slowly increase fuel pressure by turning regulator (HH) until the overflow valve opens. This can be observed since the fuel pressure gage (A) will show a sudden drop in pressure. Record the pressure. The valve should open at 33-38 psi. If not, replace the overflow valve and repeat the test. Reset fuel pressure to 5 psi.

(9) Push in drive motor start button (EE) and adjust speed to 600 rpm. Maintain this speed for five minutes to allow for warm-up.

(10) Turn lube oil regulator (JJ) to bring oil temperature to 150 degrees F. on the lube oil temperature gage (C). Turn fuel heat switch (R) to bring

fuel temperature to 150° F. as indicated on the fuel temperature gage (B). Fuel pressure to hydraulic head (compensator inlet) should be within limits shown in table 3-10 during testing of pumps.

NOTE

Run test stand long enough for the fuel to heat to 140° F. Adjust heater control as necessary to obtain this temperature.

(11) Remove operating lever dust cover. Remove socket head pipe plug from rear of governor housing on code A, B, E, and F pumps (fig. 3-163). (On code G pumps remove governor cover.) Back out droop screw (fig. 3-172) sufficiently to insure clearance between droop screw and stop plate, with operating lever in full-throttle position. The droop screw must not be in contact with the stop plate when setting full throttle fuel flow. Install governor cover on code G pumps.

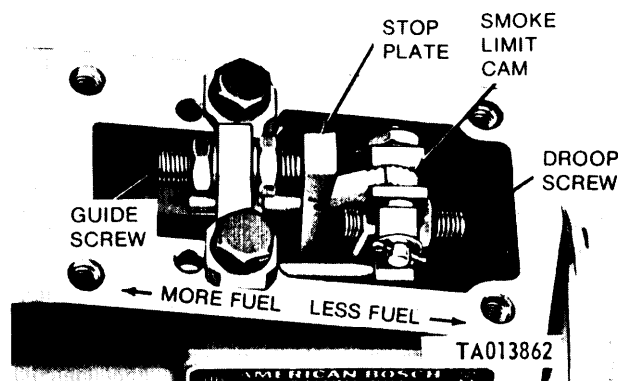

Figure 3-172. Adjusting droop screw and stop plate guide screw for desired fuel delivery (code G pumps).

NOTE

Sub paragraph (11) above does not apply to code C and D pumps as a droop screw is not used on these pumps.

(12) Check fuel return pressure on gage at pump overflow valve outlet. Pressure should not be greater than 5 psi. If pressure exceeds 5 psi, replace pump overflow valve.

c. Calibration of Code C, D, E, and G Pumps. Calibrate code C, D, and G pumps using Table 3-5 as reference. Calibrate code E pumps using Table 3-4 as reference.

(1) Use two-hole injector nozzle and holder assemblies.

(2) Adjust speed to 2850 rpm with operating lever in full-fuel position and check fuel pressure on gage (A, fig. 3-162) at compensator inlet. Fuel pressure on fuel pressure gage (A) should be 60-80 psi. If fuel pressure is below 60 psi, inspect fuel supply pump (para 3-20) and the test stand fuel

supply filters. Then if pressure is still low, replace the over-flow valve. Fuel flow should be in accordance with Table 3-4 or 3-5, depending on pump used. If reading in the burette (F, fig. 3-162) is not within specifications, push in the fuel dumping lever (E) to clear the burettes, and repeat test. If reading is not within specifications, push in fuel dumping lever to clear burettes. Fuel flow adjustment is made by adjusting high speed adjustment screw (fig. 3-173). Loosen the hex nut and turn the screw clockwise to decrease, or counterclockwise to increase the fuel delivery. Make adjustments and repeat test until specified fuel flow is attained. Tighten hex nut to lock setting of the high-speed adjustment screw

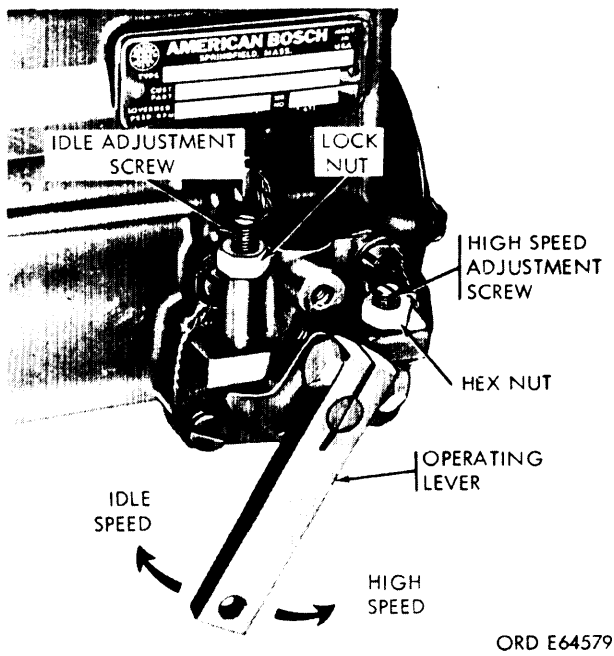

Figure 3-173. Idle and High speed adjustment.

Table 3-10. Fuel Supply Pump Pressure (To Hydraulic Head)

Speed [rpm]	Pressure [psi]
2600-3100	60-80
1200	40-55
700	30-40
150	7 (min.)

(3) Adjust speed to 2600 rpm and check fuel pressure on gage (A, fig. 3-162) at compensator inlet. Fuel pressure should be 60-80 psi. Adjust stop plate guide screw (fig. 3-174) on code C, D, and E pumps, or (fig. 3-172) on code G pumps, to obtain fuel flow per Table 3-4 or 3-5.

NOTE

Turn stop plate adjusting nut clockwise to decrease fuel and counterclockwise to increase fuel, as viewed at the governor end of the pump. If fuel flow limit can not be obtained by adjusting the stop plate, it will be necessary to inspect the fuel control rod

linkage (para 3-25). Replace defective parts, and repeat the tests to obtain specified fuel flow. Check governor spring and spacers (fig. 3-142, 3-143, 3-144, and 3-145).

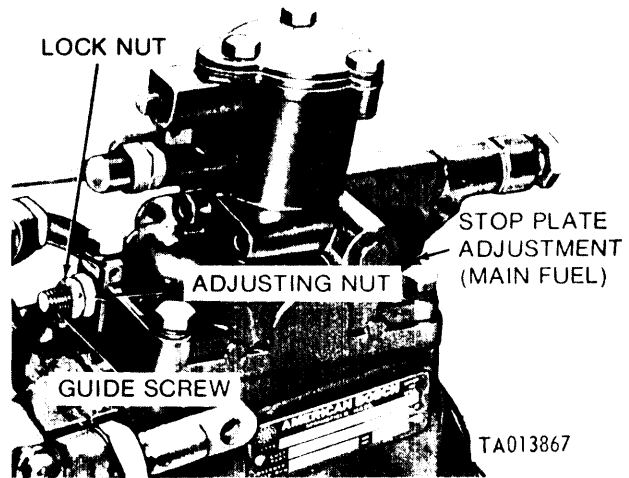

Figure 3-174. Adjusting stop plate guide screw and stop plate for desired fuel delivery (code C, D, and E pumps).

(4) Increase pump speed to 2940 rpm and check fuel flow. Flow should be 5 cc or less. If reading of 5 cc or less is not obtained, it will be necessary to stop the test and check the high speed (inner) governor spring spacer(s). See Table 3-11 for proper spacer dimensions (refer to para 3-43). Check for use of the correct spring (fig. 3-143). Check control unit for pin wear (para 3-44).

NOTE

Adding spacers to the governor spring will increase fuel delivery, and decreasing spacers will decrease fuel delivery. Repeat 2940 rpm fuel flow check, and add or remove spacers to obtain a fuel flow of 5 cc maximum.

(5) Adjust speed to 1400 rpm and check fuel pressure on gage (A, fig. 3-162) at compensator inlet. Fuel pressure should be 40-55 psi. Check fuel flow per Tables 3-5 or 3-4 respectively. (This is a reference point only.) No adjustment is required on C and D pumps. Adjust setscrew (droop screw) (J, fig. 3-67) on code E pumps. Turn screw clockwise to decrease fuel delivery, and counterclockwise to increase fuel delivery. (Code C and D pumps do not have a droop screw.)

(6) If fuel flow cannot be adjusted to these limits, check engagement of compensator stop plate and linkage on code C, D, and E pumps and angular position of smoke limit torque cam on all pumps (table 3-8). (Refer to figure 4-73.) Raising the cam to a greater angle will increase fuel flow and decreasing the cam angle will decrease the flow. Recheck fuel flow.

(7) Reduce speed to 700 rpm and check fuel pressure on gage (A, fig. 3-162) at compensator inlet (code C, D, and E pumps) or head inlet (code G

pumps). Fuel pressure should be 30-40 psi. With operating lever in idle position, adjust low-idle speed screw to obtain fuel flow per Table 3-5 or 3-4. If reading is not within limit, loosen idle adjustment screw locknut and turn idle adjustment screw (fig. 3-173). Turn screw clockwise to increase fuel delivery and counterclockwise to decrease fuel delivery. Adjust screw to obtain specified flow, and tighten screw locknut.

(8) Check 2600 rpm full-load fuel flow. If fuel flow does not fall within limits repeat steps (2) through (7) above.

(9) Reduce test stand rpm to a minimum. When speed reaches minimum push drive motor stop button (DD, fig. 3-162) and turn speed shifting crank (S) to LOW RANGE.

(10) Restart the test stand and adjust speed to 150 rpm with operating lever in full-load position, set count at 1000 and collect fuel in fuel burettes. Check fuel pressure gage (A). Reading should be 7 psi minimum. Fuel flow should be in accordance with Table 3-5 or 3-4. If fuel pressure is below 7 psi, inspect fuel supply pump (para 3-20). If fuel flow is below the specified minimum, the hydraulic head and plunger are excessively worn and the head must be replaced. Replace hydraulic head assembly if proper flow is not obtained, and retest the pump.

(11) Pull injection pump fuel shutoff rod. Fuel should stop flowing immediately each time the rod is pulled. If fuel does not stop, check fuel shutoff to make certain the rod is properly engaged with the control unit lever.

(12) On code G pumps, set droop screw per special instructions in Table 3-5. On code E pumps, set droop screw per special instructions in Table 3-4.

d. Calibration of Code B and F Pumps. Calibrate injection pump code B or F using Table 3-6.

(1) Use two-hole injector nozzle and holder assemblies (fig. 3-163, 3-169 and 3-170) with code F pump, and one-hole injector nozzle and holder assemblies with code B injection pump.

NOTE

Code B pumps used to replace code F pumps must be calibrated with two hole nozzles. After calibration, tag the pump making one of the following statements as applicable:
FOR USE ON CODE B ENGINE ASSEMBLY (LDS-465-1A)
FOR USE ON CODE F ENGINE ASSEMBLY (LDS-465-1)

(2) Adjust speed to 2850 rpm and check fuel pressure on gage (A, fig. 3-162) at compensator inlet. Fuel pressure should be 60-80 psi. Fuel flow should be in accordance with Table 3-6, depending on fuel used. Fuel flow adjustment is made by adjusting high-speed adjustment screw (fig. 3-173). (See step c. (2) above for procedure.)

(3) Adjust speed to 2600 rpm and check fuel pressure on gage (A, fig. 3-162) at compensator inlet. Fuel pressure should be 60-80 psi. Adjust stop plate guide screw (fig. 3-174) to obtain fuel flow per table 3-6. (See step c. (3) above for procedure,)

(4) Adjust speed to 2940 rpm and check fuel

flow, Flow should be 5 cc or less to meet specification. If fuel flow is not to limit, the pump must be shut down and the high-speed (inner) governor spring and spacer(s) must be checked and adjusted. (See step c. (4) above for procedure). Check condition of fuel control unit and pin (para 3-44).

(5) Adjust speed to 1200 rpm and check fuel pressure on gage (A, fig. 3-162) at compensator inlet. Fuel pressure should be 40-55 psi. Adjust droop screw to obtain fuel flow per Table 3-6. (See step c. (5) and c. (6) above for procedure.)

(6) If fuel flow cannot be adjusted to these limits, check engagement of compensator stop plate and linkage and angular position of smoke limit torque cam. (See steps c (5) and (6) above for procedure.)

(7) Reduce speed to 700 rpm and check fuel pressure on gage (A, fig. 3-162) at compensator inlet. Fuel pressure should be 30-40 psi. With operating lever in idle position, adjust low idle adjustment screw (fig. 3-173) to obtain fuel flow per Table 3-6. (See step c(7) above for procedure.)

(8) Check 2600 rpm full-load fuel flow. If fuel flow does not fall within limits, repeat (2) through (7) above.

(9) Reduce test stand rpm to a minimum. When speed reaches minimum, push drive motor stop button (DD, fig. 3-162) and turn speed shifting crank (S) to LOW RANGE.

(10) Restart the test stand and adjust speed to 150 rpm with operating lever in full-load position. Set count at 1000 and collect fuel in fuel burettes. Fuel flow should be in accordance with Table 3-6. If the fuel flow is below specified limit, the hydraulic head and plunger are excessively worn and the head must be replaced. Replace hydraulic head assembly if proper flow is not obtained, and retest the pump.

(11) Pull injection pump fuel shut-off rod. Fuel should stop flowing immediately each time the rod is pulled. If fuel does not stop, check fuel shut-off to make certain the rod is properly engaged with the control unit lever.

e. Calibration of Code A Pump. Calibrate code A injection pump using Table 3-7.

(1) Use one-hole nozzle and holder assemblies.

(2) Adjust speed to 3100 rpm and check fuel pressure on gage (A, fig. 3-162) at compensator inlet. Fuel pressure should be 60-80 psi. Fuel flow should be in accordance with Table 3-7, depending on fuel used, Fuel flow adjustment is made by adjusting high-speed adjustment screw (fig. 3-173). (Refer to step c (2) above for procedure.)

(3) Adjust speed to 2800 rpm and check fuel pressure on gage (A, fig. 3-162) at compensator inlet. Fuel pressure should be 60-80 psi. Adjust stop plate guide screw (fig. 3-174) to obtain fuel flow per Table 3-7. (Refer to c (3) above for procedure.)

(4) Adjust speed to 3150 rpm and check fuel flow. Flow should be 5 cc or less to meet specification. If fuel flow is not within limit, the pump must be shut down and the high-speed (inner) governor spring must be checked and adjusted. (See

step c (4) above for procedure.) Check condition of fuel control unit and pin (para 3-44).

(5) Reduce speed to 1200 rpm and check fuel pressure on gage (A, fig. 3-162) at compensator inlet. Fuel pressure should be 40-55 psi. Adjust droop screw to obtain fuel flow per Table 3-7. (Refer to c (5) and (6) above for procedure.)

(6) If fuel flow cannot be adjusted to these limits, check engagement of compensator stop plate, torque link stop and guide, and the angular position of smoke limit torque cam. (Refer to c (6) above for procedure.)

(7) Reduce speed to 700 rpm and check fuel pressure on gage (A, fig. 3-162) at compensator inlet. Fuel pressure should be 30-40 psi. With operating lever in idle position, adjust low-idle adjustment screw (fig. 3-173) to obtain fuel flow per Table 3-7. (Refer to c (7) above for procedure.)

(8) Check 2800 rpm full-fuel flow. If fuel flow does not fall within limits, repeat (2) through (7) above.

(9) Reduce test stand rpm to a minimum. When speed reaches minimum, push drive motor stop button (DD, fig. 3-162), and turn speed shifting crank (S) to LOW RANGE.

(10) Restart the test stand and adjust speed to 150 rpm, with operating lever in full fuel position. Set count at 1000 and collect fuel in fuel burettes. Fuel flow should be in accordance with Table 3-7. If the fuel flow is below specified limit, the hydraulic head and plunger are worn excessively and the head must be replaced. Replace hydraulic head assembly if proper flow is not obtained, and retest the pump.

(11) Activate fuel injection pump electric solenoid fuel shut-off. Apply 24 v dc to solenoid electrical connection. Fuel should stop flowing immediately each time the solenoid is activated. If shut-off does not operate, replace solenoid (para 3-47).

(12) Check operating lever travel with template, 5120-134-7462, as shown in fig. 3-175. Template should be held flush against side of transfer pump with center line mark aligned with shaft. Center line of lever must fall within lines indicated. If not within template limits, check governor spacers and springs, gaps and preloads, operating lever to operating shaft position, and smoke limit torque cam angle. If corrections are necessary, fuel flow of pump should be rechecked after any adjustments are made.

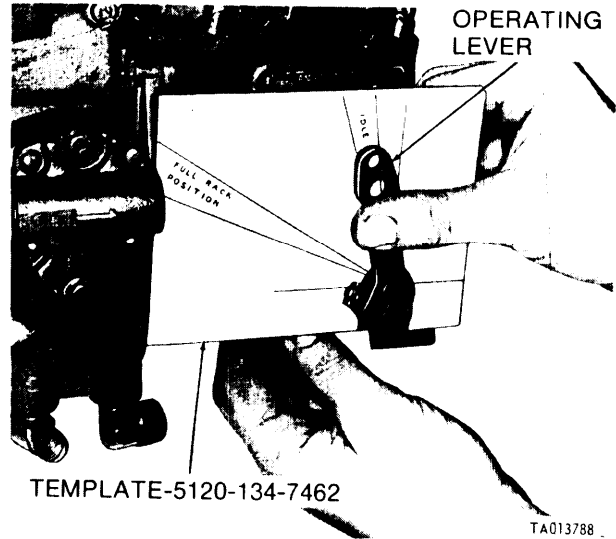

Figure 3-175. Checking operating lever position (code A pumps).

f. *Shut-down of Test Stand After Pump Calibration.* (Refer to fig. 3-162). Push drive motor stop button (DD) to stop test stand. Turn off the fuel and lube oil heat switches (R and T), the 500.1000-OFF count switch (V), the FORWARD-OFF-Reverse switch (CC), and the auxiliary motor switch (AA). Back off the fuel and lube oil regulators (JJ, HH). Push test stand 24-volt button (P).

g. *Removal of Pump from Test Stand,*

(1) Refer to figures 3-163, 3-169 and 3-170, and disconnect and remove the following hoses:

(a) Test stand lube pressure-to-fuel injection pump hose (E) to the fuel injection pump oil inlet fitting in the advance housing.

(b) Fuel injection pump lube return-to-test stand lube return hose (F) to the test stand lube oil return.

(c) Test stand fuel pressure-to-supply pump inlet hose (A) to the inlet port of the fuel injection pump fuel supply pump.

(d) Fuel injection pump fuel outlet-to-compensator inlet hose (B) to the adapter (J) at the compensator inlet tee (H) (on code G pumps the hose to the hydraulic head).

(e) Compensator inlet tee pressure gage hose (C) to the fuel pressure gage (or panel connection).

(f) Overflow valve-to-test stand fuel return hose (D) to the test stand fuel return.

(2) Remove improvised manifold (fig. 3-163 or 3-169) consisting of adapters (J and K), tee (H), and elbow (G) from the compensator inlet tee (on code G pumps remove adapter) (C, fig. 3-165), coupling (B) and elbow (A) from elbow at hydraulic head inlet.

(3) Disconnect and remove the tube assemblies from the pump head to the test nozzles (fig. 3-169).

(4) Remove throttle holding spring (fig. 3-163). Install pipe plug in rear of governor housing (A, B, E, and F pumps).

(5) Loosen the pump and bracket clamp holding the pump to the rails, and tip the pump assembly to drain oil and fuel. Remove pump from test stand.

(6) Plug or cap openings in pump to prevent entry of dirt.

(7) Remove the retaining nut and lockwasher on the pump shaft, and remove the test stand drive hub from the pump,

(8) Remove the adapter ring and bracket from the pump.

(9) Torque tighten high-speed adjustment screw hex nut and the idle adjustment screw locknut to 50-60 inch-pounds (fig. 3-173).

(10) On code A pumps, install locking wire on the two socket head screws attaching the electric fuel shutoff solenoid to the pump.

(11) Install locking wire on the governor end cover screws and quill shaft access plate screws.

(12) Install seals to prevent unauthorized tampering of pump adjustments as follows. Refer to figures 3-176 and 3-177.

(a) *Upper dust cover.* Install new seal, inserting the wire through the hole in the head of the capscrew and through the boss protruding from the cover. Crimp the seal using sealing pliers.

(b) *Closure cover on fuel adjustment.* Install cover over the fuel adjustment guide locknut on the density compensator housing flange, using the two drilled head housing mounting screws. Install the new lead seal by threading the sealing wire through the front compensator to governor housing screws. Insert wire through the lead seal and crimp using sealing pliers.

(c) *Compensator servo pressure valve.* Pumps with fuel density compensators should have seals in place. If they are not, install sleeve, and thread wire of lead seal as shown in figure 3-177, and crimp using sealing pliers.

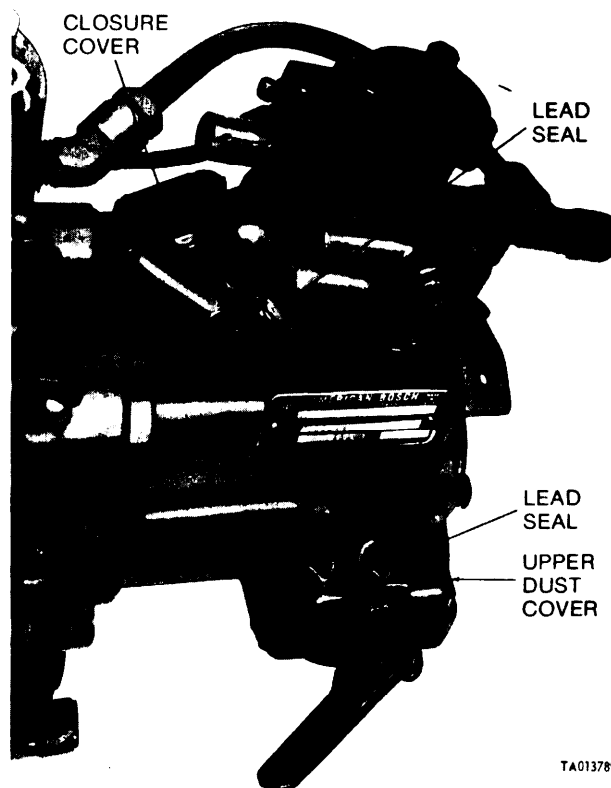

TA013789

Figure 3-176. Tamper-proof covers, installed view.



TA013790

Figure 3-177. Installation of seal wire on fuel density compensator servo-pressure valve sleeve.

(13) Identify pump with a suitable tag giving model of engine pump is to be used on, and the FSN number of the pump.

h. Pump Preservation. Preservation and packaging of the pump must be sufficient to afford adequate protection against corrosion, deterioration, and physical damage during storage and shipment from the repair source to the user. Prepare the pump to meet these requirements.

Table 3-11. Governor Inner and Outer Spacer Dimensions

Pump code	Engine model	Outer spring	Inner spring
A	LDS-465-2	0.040-0.060 in.	0.100-0.120 in.
B	LDS-465-1A	0.020.040 in.	0.100-0.120 in.
C	LD-465-1	0.040-0.060 in.	0.100.0.120 in.
D	LD-465-1C	0.040-0.060 in.	0.100-0.120 in.
E	LDT465-1C	0.020-0.040 in	0.100-0.120 in.*
E	LDT465-1C	0.040-0.060 in.	0.100-0.120 in.**
F	LDS-465-1	0.020-0.040 in.	0.100-0.120 in.
G	LDS-427-2	0.080-0.100 in.	0.100-0.120 in.

* INJ Pump P/N 10935264-1

** INJ Pump P/N 10935264-2

Section VI. REPAIR STANDARDS

3-59. General. The repair standards give minimum, maximum, and important clearances of new or rebuilt parts. They also give wear limits which indicate that point to which a part or parts may be worn before replacement. Normally, all parts which have not worn beyond dimensions shown in "Wear limits" column or damaged by cor-

rosion will be approved for service. An asterisk (*) in "Wear limits" column indicates that part or parts should be replaced when worn beyond limits given in "Sizes and fits of new parts" column. In "Sizes and fits of new parts" column, the letter L indicates a loose fit (clearance) and the letter T indicates a tight fit (interference). All dimensions shown are in inches.

3-60. Injection Pump Assembly.

Fig. No.	Ref. letter	Point of measurement	Sizes end fits of new parts	Wear limits (direct and general support maintenance)	
B-2	a	ID of pin hole in fuel control unit	0.0935 to 0.0942	0.0947	
	b	Thickness of flats of plunger sleeve pin	0.0993 to 0.1000	0.0990	
	c	OD of plunger sleeve pin	0.0927 to 0.0933	0.0924	
	a-c	Fit of pin in control unit	0.0002L to 0.0015L	0.0020L	
	d	Rod return spring: Free length	2.0000		
B-3		Lb compression at 1.4930-inch length	0.45 to 0.55 lbs.	*	
	a	OD of sleeve end of camshaft	0.3735 to 0.3740	0.3710	
	b	Governor inner spring: Spring SP 7950-16, No. 10951113, FSN 2910-836-7316 (for LDS-465-2, code A Pump).			
			Free length, inches	1.9530 to 2.0470	1.9150
			Spring rate, lbs/in	175	170
		Lbs. compression at 1.8000-inch length	33.25 to 36.75	31.6	
	b	Spring SP7950-11, No. 10923499, FSN 2990-850-3260 (all but LDS-465-2 & LDT-465 Pumps) (used on B, C, D, F, G Pumps).			
			Free length, inches	1.9530 to 2.0470	1.9150
			Spring rate, lbs/in	150	145
		Lbs. compression at 1.8000 inch length	28.5 to 31.5	27.1	
	b	Spring SP7950-22, No. 11668460, FSN 5360-081-6977 (for LDT-46S, code E Pumps).			
			Free length, inches	1.9530 to 2.0470	1.9150
			Spring rate, lbs/in	72	68
		Lbs. compression at 1.8000-inch length	25.6 to 28.4	25.5	
	c	Governor outer spring: Spring SP7951-11, No. 10923488, FSN 2910-846-4659 (LDS-427-2, code G Pump).			
		Free length, inches	1.5150 to 1.6090	1.4750	
		Spring rate, lbs/in.	20	19.2	
		Lbs. compression at 1.4000-inch length	3.10 to 3.40	2.95	
c		Spring SP7951-12, No. 11588685, FSN 5340-930-5140 (all LD/LDS-465 Pumps) (used on A, B, C, D, F Pumps).			
			Free length, inches	1.5150 to 1.6090	1.4750
		Spring rate, lbs/in.	30	28.8	
	Lbs. compression at 1.4000-inch length	4.61 to 5.09	4.40		

*See paragraph 3-59.

Fig No	Ref. letter	Point of measurement	Sizes and fits of new parts	Wear limits (direct and general support maintenance)	
B-3		Spring SP7951-13, No. 7383463, FSN 2990-830-3882 (used on LDT-465, code E Pumps).			
		Free length, inches	1.5150 to 1.6090	1.4750	
		Spring rate, lbs/in	40	38.0	
		Lbs. compression at 1.4000-inch length	6.2 to 6.77	6.0	
	d	OD of bracket pivot pin	0.2490 to 0.2495	0.2485	
	e	ID of shaft spring plate	0.5000 to 0.5010	0.5015	
	f	Length of operating shaft bearing hub	1.1860 to 1.1900	*	
	g	OD of operating shaft bearing hub	0.4980 to 0.4990	0.4970	
	e-g	Fit of plate on bearing hub	0.0010L to 0.0030L	0.0035L	
	h	OD of operating shaft end	0.2485 to 0.2495	0.2480	
	j	OD of fulcrum sleeve pins	0.2495 to 0.2505	0.2460	
	k	ID of fulcrum lever pivot pin holes	0.2500 to 0.2510	*	
	d-k	Fit of fulcrum lever on pin	0.0005L to 0.0020L	0.0025L	
	h-k	Fit of fulcrum lever on operating shaft	0.0005L to 0.0025L	0.0030L	
	l	ID of sliding sleeve	0.3746 to 0.3756	0.3780	
	a-l	Fit of sleeve on camshaft	0.0006L to 0.0021L	0.0070L	
	m	Width of slots in sliding sleeve	0.2510 to 0.2530	0.2550	
	j-m	Fit of sliding sleeve on sleeve pin	0.0005L to 0.0035L	0.0050L	
	B-4		OD of camshaft ball bearing	2.0467 to 2.0472	*
		a	OD of camshaft ball bearing journal	0.9842 to 0.9846	0.9840
			OD of bushing type bearing journal	0.8110 to 0.8115	0.8100
		d	Plunger outer spring:		
			Spring SP-9038, No. 10947155, FSN 2910-903-4803 (used on A, B, C, D, E, F) (used on all but LDS-427, code G Pump).		
		Free length, inches	1.072		
		Spring rate, lbs/in.	400	380	
		Lbs. compression at 1.000-inch length	27 to 31	23	
		Lbs. compression at .765-inch length	118 to 128	110	
		Spring SP903, No. 10944587, FSN 2910-619-7586 (used on LDS-427-2, code G Pumps).			
		Free length, inches	1.769		
		Spring rate, lbs/in.	109	102	
		Lbs. compression at 1.3170-inch length	47 to 52	43	
		Lbs. compression at 1.0810-inch length	71 to 79	67.5	
e		OD of tappet assembly	1.3105 to 1.3115	1.3100	
f		ID of tappet bore in housing	1.3125 to 1.3135	1.3170	
e-f		Fit of tappet in housing	0.0010L to 0.0030L	*	
g		ID of bushing type bearing bore in housing	0.9061 to 0.9066	*	
h		ID of camshaft bushing type bearing	0.8123 to 0.8134	0.8154	
c-h		Fit of camshaft unbearing	0.0008L to 0.0024L	0.0044L	
j		OD of camshaft bushing type bearing	0.9080 to 0.9090	*	
g-j		Fit of bushing in housing	0.0014T to 0.0029T	*	
k		ID of amshaft ball bearing bore in housing	2.0462 to 2.0468	*	
a-k	Fit of ball bearing in housing	0.000IL to 0.0010T	*		
l	ID of camshaft ball bearing	0.9839 to 0.9843	*		
b-l	Fit of ball bearing on camshaft	0.000IL to 0.0007T	*		

* See paragraph 3-59

3-61. Tappet Assembly.

Fig No.	Ref. letter	Point of measurement	Sizes and fits of new parts	Wear limits (direct and general support maintenance)
B-8		GUIDE ASSEMBLY GU9021A, PIN P/N 9039, ROLLER ASSY. PL768A (CODES A, B, C, D, E, F Pumps)		
	a	ID of roller bushing type bearing	0.4732 to 3.4739	0.4745
	b	OD of tappet roller pin	0.4723 to 0.4725	0.4720
	a-b	Fit of pin in roller bearing	0.0007L to 0.0016L	0.0018L
	c	OD of tappet roller	0.9839 to 0.9845	0.9837
	d	ID of pin bore in guide	0.4730 to 0.4738	0.4729
	b-d	Fit of pin in guide bore	0.0005L to 0.0015L	0.0016L
		GUIDE ASSEMBLY GU9011A, PIN P/N 9013, ROLLER ASSY. PL903A (USED ON CODE G PUMP)		
		ID of roller bushing type bearing	0.3749 to 0.3754	0.3760
	a	OD of tappet roller pin	0.3742 to 0.3745	0.3739
	a-b	Fit of pin in bushing	0.0004L to 0.0012L	0.0014L
	c	OD of tappet roller	0.6689 to 0.6693	0.6688
	d	ID of bore in guide	0.3750 to 0.3758	0.3760
	b-d	Fit of pin in guide bore	0.0005L to 0.0016L	0.0018L

3-62. Fuel Supply Pump Assembly.

Fig. No.	Ref. letter	Point of measurement	Sizes and fits of new parts	Wear limits (direct and general support maintenance)
B-5	a	ID of shaft bore in housing	0.4375 to 0.4380	1
	b	OD of idler gear pin	0.3121 to 0.3124	1
	c	ID of idler gear.	0.3125 to 0.3130	1
	b-c	Fit of gear on pin.	0.0001L to 0.0009L	*
	d	OD of drive shaft	0.4365 to 0.4370	1
	a-d	Fit of shaft in housing.	0.0006L to 0.0010L	1
	e	Check valve spring:		
		Free Length.	0.5420	
		Spring rate	63 to 70	61/3
		Lb compression at 0.3120-inch length	14 to 18 lbs	13.6 lbs
		Overflow valve spring in Pump Cover:		
		(1) Spring SP 9044, (CV9057A, 80 psi) (used on LDS-465-2, code A Pump).		
		Free length, inches	1.995	1.95
		Spring rate, lbs/in.	37.5	36.0
		Lbs. compression at 0.890-inch length	3.9	3.8
		Lbs. compression at 0.680-inch length	11.7	11.3
		(2) Spring SP7961, (CV9052A, 60 psi) (used on LDS-465-1, code F Pump)		
	Free length, inches.	1.000		
	Spring rate, lbs/in.	30		
	Lbs. compression at 0.840-inch length	4.55	4.4	

* See paragraph 3-59.

3-63. Advance Unit Assembly

Fig No	Ref. letter	Point of measurement	Sizes and fits of new parts	Wear Limits (direct and general support maintenance)
B-7	a	OD of housing brushing type bearing	1.0025 to 1.0035	*
	b	ID of bearing bore in housing	0.9995 to 1.0005	*
	a-b	Fit of bearing in housing	0.002m to 0.0040T	*
	c	OD of weight and spider shaft	0.8090 to 0.8095	0.8085
	c	ID of housing bushing type bearing.. . . .	0.8098 to 0.8107	0.8127
	c d	Fit of shaft in bearing	0.0003L to 0.0017L	0.0024L
	e	Advance unit springs:		
		(1) Spring SP9041(used encode B, F, G Pumps)		
		Freelength, inches	1.5420	
		Spring rate, lbs/in	69	66.6
		Lbs. compression at 1.4000-inch length	9.3 to 10.3	8.8
		Lbs. compression at 1.0000-inch length	35.3 to 39.3	33.0
		(2) Spring SP9043 (used on codes C, D, E Pumps).		
		Freelength, inch	1.7730	
		Spring rate, lbs/in	55	53.2
		Lbs. compassion at 1.4000-inch length	19.6 to 21.6	18.6
		Lbs. compression at 1.0000-inch length	40.6 to 44.6	29.2
	(3) Spring SP857-3 (used on code A Pump).			
	Freelength, inches	1.5330		
	Spring rate, lbs/in	102.5		
	Lbs. compression at 1.0000-inch length	51.3 to 56.7	49.5	

* See paragraph 3-59

3-64. Torque Specifications

Figure		Torque Value
3-43	Fuel supply pump cover screws	30-35 inch-pounds
3-58	Dust cover screw	50-60 inch-pounds
3-67	Fulcrum lever hex nut	50-60 inch-pounds
3-67	Fulcrum lever self-locking nut	12-14 inch-pounds
3-81	Stop lever clamping screw	50-60 inch-pounds
3-84	Operating lever clamping nut.....	70-75 inch-pounds
3-85		
3-90	Governor weight and spider assembly hubnut.	80-85 foot-pounds
3-93	Covernor weight and spider assembly function drive slippage.	48-72 inch-pounds
3-105	Camshaft bearing retaining locknut.	25-40 foot-pounds
3-116	Quill shaft attaching screw	80-90 inch-pounds
3-117	Quill shaft cover attaching screws	50-60 inch-pounds
3-122	Hydraulic headattaching nuts.....	18-20 foot-pounds
3-123	Oil filter screw	20-25 foot-pounds
3-126	Camshaft nut	50-55 foot-pounds
3-126	Camshaft nut setscrew	15-18 foot-pounds
3-135	Advance unit attaching screws.....	17-20 foot-pounds
3-140	Governor attaching screws	50-60 inch-pounds
3-147	Governor end attaching screws	50-60 inch-pounds
3-151	Control unit attaching screws	18-23 inch-pounds
3-153	Density compensator attaching screws	50-60 inch-pounds
3-173	High-speed adjustment screw hex nut	50-60 inch-pounds
3-173	Idle adjustment screw locknut	50-60 inch-pounds

APPENDIX A

REFERENCES

The following is a list of the publications referenced within this manual.

- | | |
|--------------------|--|
| TM 38
750 | The Army Maintenance Management System (TAMMS) |
| TM 9-2815-210-35 | DS, GS, and Depot Maintenance Manual: Engine, Diesel (Multifuel): Turbocharged, Fuel Injected, Water Cooled 6 Cylinder Assembly, 2815-076-5998 (Military Model LDS-465-1); Engine, Diesel (Multifuel): Fuel Injected Water Cooled, 6-Cylinder Assembly -2815-010-5170 (Military Model LD-465-1); Engine, Diesel (Multifuel): Turbocharged; Fuel Injected, Water Cooled, 6-Cylinder Assembly-2815-91 1-3644 (Military Model LDS-465-1A); Engine, Diesel (Multifuel): Turbocharged, Fuel Injected, Water Cooled, 6-Cylinder, Assembly- 2815-808-7998 (Military Model LDS-465-2). |
| TM 9-2815-204-35 | Field and Depot Maintenance for Engine, Diesel (Multi-Fuel): Turbosupercharged Fuel Injected, Water Cooled, 6-Cylinder Assembly-2815-897-5061 (Continental Model LDS-427-2) and Clutch, Assembly (ORD 7748995) (Long Model 13CF) End Item Application: Truck, Cargo: 2½-Ton, 6x6, M35A1 (Multifuel) (TM 9-2320-209). |
| TM 9-2815 -210-34P | Direct Support and General Support Maintenance Repair Parts and Special Tools List (Including Depot Maintenance Repair Parts and Special Tools): Engine, Diesel (Multifuel): Turbocharged, Fuel Injected, Water Cooled, 6-Cylinder Assembly (Military Models LD-465-1, 2815-239-5824; LD-465-1C, 2815-134-4830; LDT-465-1C, 2815-103-2642; LDS-465-1, 2815-075-0087; LDS-465-1A, 2815-239-5819; And LDS-465-2; 2815-808-8011 and Clutches) |
| TM 9-214 | Inspection, Care and Maintenance of Antifriction Bearings. |
| TM 9-4910-387-12 | Operator and Organizational Maintenance Manual: Tester Fuel Injection Pump, 220V, 60C, 3-PH |

APPENDIX B

DIRECT SUPPORT, GENERAL SUPPORT, AND DEPOT MAINTENANCE REPAIR PARTS AND SPECIAL TOOLS LISTS

Section I. INTRODUCTION

B-1. Scope. *a.* This appendix lists repair parts, special tools, and special purpose kits required for the performance of organizational, direct support, general support, and depot maintenance of the metering and distributing fuel pumps used on multifuel diesel engine assemblies.

b. Illustrated items are keyed by numbers to their text listing.

B-2 General. This repair parts and special tools list is divided into the following sections:

a. Repair Parts – Section II. A list of repair parts authorized for the performance of maintenance at the direct support, general support, and depot level in figure and item number sequence.

b. Special Tools, Test and Support Equipment – Section III. A list of special tools, test and support equipment authorized for the performance of maintenance at the direct support, general support, and depot level.

c. Federal Stock Number and Part Number Index – Section IV. A list of Federal stock numbers in ascending numerical sequence followed by a list of reference numbers in ascending alphanumeric sequence, cross referenced to the illustration figure number and item number.

B-3. Explanation of Columns. The following provides an explanation of columns found in the tabular listings.

Source, Maintenance and Recoverability Codes (SMR), Column (1).

(1) *Source code.* Source codes are assigned to support items to indicate the manner of acquiring support items for maintenance, repair, or overhaul of end items. Source codes are entered in the first and second positions of the uniform SMR code format as follows:

<i>Code</i>	<i>Definition</i>
PA	Items procured and stocked for anticipated or known usage.
PB	Items procured and stocked for insurance purpose because essentiality dictates that a minimum quantity be available in the supply systems,
PC	Item procured and stocked and which otherwise would be coded PA except that it is deteriorative in nature.
PD	Support item, excluding support equipment, procured for initial issue or outfitting and stocked only for subsequent or additional initial issues or outfitting. Not subject to automatic replenishment.

<i>Code</i>	<i>Definition</i>
PE	Support equipment procured and stocked for initial issue or outfitting to specified maintenance repair activities.
PF	Support equipment which will not be stocked but which will be centrally procured on demand.
PG	Item procured and stocked to provide for sustained support for the life of the equipment. It is applied to an item peculiar to the equipment which because of probable discontinuance or shutdown of production facilities would prove uneconomical to reproduce at a later time.
KD	An item of depot overhaul/repair kit and not purchased separately. Depot kit defined as a kit that provides items required at the time of overhaul or repair.
KF	An item of a maintenance kit and not purchased separately. Maintenance kit defined as a kit that provides an item that can be replaced at organizational or intermediate levels of maintenance.
KB	Item included in both a depot overhaul/repair kit and a maintenance kit.
MO	Item to be manufactured or fabricated at organizational level.
MF	Item to be manufactured or fabricated at the direct support maintenance level.
MH	Item to be manufactured or fabricated at the general support maintenance level.
MD	Item to be manufactured or fabricated at depot maintenance level.
AO	Item to be assembled at organizational level.
AF	Item to be assembled at the direct support maintenance level.
AH	Item to be assembled at the general support maintenance level.
AD	Item to be assembled at depot maintenance level.
XA	Item is not procured or stocked because the requirements for the item will result in the replacement of the next higher assembly.
XB	Item is not procured or stocked. If not available through salvage, requisition.
XC	Installation drawing, diagram, instruction sheet, field service drawing, that is identified by manufacturer's part number.
XD	A low mortality support item that is not stocked. When required, item will be procured or requested through normal supply channels.

NOTE

Cannibalization or salvage may be used as a source of supply for any items coded above except those coded XA.

(2) *Maintenance code.* Maintenance codes are assigned to indicate the levels of maintenance authorized to USE and REPAIR support items. The maintenance codes are entered in the third and

fourth positions of the Uniform SMR Code format as follows:

Use (third position): The maintenance code entered in the third position will indicate the lowest maintenance level authorized to remove, replace, and use the support item. The maintenance code entered in the third position will indicate one of the following levels of maintenance.

Code	<i>Application/Explanation</i>
C	Crew or operator maintenance performed within organizational maintenance.
O	Support item is removed, replaced, used at the organizational level.
F	Support item is removed, replaced, used at the direct support level.
H	Support item is removed, replaced, used at the general support level.
D	Support items that are removed, replaced, used at depot, mobile depot, specialized repair activity only.

Repair (fourth position): The maintenance code entered in the fourth position indicates whether the item is to be repaired and identifies the lowest maintenance level with the capability to perform complete repair (i.e., all authorized maintenance functions). This position will contain one of the following maintenance codes as assigned by the service(s) that require the code:

Code	<i>Application/Explanation</i>
O	The lowest maintenance level capable of complete repair of the support item is the organizational level.
F	The lowest maintenance level capable of complete repair of the support item is the direct support level.
H	The lowest maintenance level capable of complete repair of the support item is the general support level.
D	The lowest maintenance level capable of complete repair of support item is the depot level.
L	Repair restricted to designated specialized repair activity.
Z	Nonrepairable. No repair is authorized.
B	No repair is authorized. The item may be reconditioned by adjusting, lubrication; etc., at the user level. No parts or special tools are procured for the maintenance of this item.

(3) *Recoverability code.* Recoverability codes are assigned to support items to indicate the disposition action on unserviceable items. The recoverability code is entered in the fifth position of the uniform SMR code format as follows:

<i>Recover-Ability codes</i>	<i>Definition</i>
Z	Nonrepairable item. When unserviceable, condemn and dispose at the level indicated in position 3.
O	Repairable item. When uneconomically repairable, condemn and dispose at organizational level.
F	Repairable item. When uneconomically repairable condemn and dispose at the direct support level.
H	Repairable item. When uneconomically repairable, condemn and dispose at the general support level.
D	Repairable item. When beyond lower level repair capability, return to depot. Condemnation and disposal not authorized below &pot-level.

<i>Recoverability codes</i>	<i>Definition</i>
L	Repairable item. Repair, condemnation and disposal not authorized below depot/specialized repair activity level.
A	Item requires special handling or condemnation procedures because of specific reasons (i.e., precious metal content, high-dollar value, critical material or hazardous material). Refer to appropriate manuals/directives for specific instructions.

b. Federal Stock Number, Column (2). This column indicates the Federal stock number assigned to the item and will be used for requisitioning purposes.

NOTE

Federal stock numbers that are missing for P source coded items are not currently recorded in the AMDF. When these stock numbers are broadcast in the AMDF they will be provided by a change to the manual.

c. Description, Column (3). This column indicates the Federal item name and any additional description of the item required. A part number or other reference number is followed by the applicable five-digit Federal supply code for manufacturers in parentheses. Repair parts quantities included in the kits, sets, and assemblies are shown in front of the repair part name. The Description column also has headings denoting the grouping that the parts belong to.

d. Unit of Issue, Column (4). A two-character alphabetic abbreviation indicating the amount or quantity of the item upon which the allowances are based; e.g., ft, ea, pr; etc.

e. Quantity Incorporated in Unit, Column (5). This column indicates the quantity of the item used in pump assembly of which it is a part. A V appearing in this column in lieu of a quantity indicates that a definite quantity cannot be indicated (e. g. shims, spacers, etc.).

f. 30-Day DS/GS Maintenance Authorization, Columns (6) and (7).

(1) The repair parts list includes asterisk entries in separate columns — one for direct support (DS) and one for general support (GS) — as appropriate to indicate the total range of repair parts authorized for use at that category or required to be removed or disassembled during the performance of authorized maintenance operations. They will be requisition initially on an “as required” basis. The repair parts authorized at the DS/GS levels will be those authorized for the maintenance mission at these levels. Requirements for repair parts stockage and for distribution to supported units will be based on demand and determined in accordance with AR 710-2.

(2) Special tools or test, measurement, and diagnostic equipment (TMDE) and other support equipment peculiar to an item are listed with quantities in the appropriate density spread/allowance columns.

g. *1-Year Allowances per 100 Equipments/contingency Planning Purposes, Column (8)*. This column indicates the requirement for contingency planning purposes. An asterisk indicates authorization to obtain or use as required. This column is left blank except for the special tools list.

h. *Depot Maintenance Allowances per 100 Equipment, Column (9)*. This column indicates authorization for depot use. This column is left blank.

i. *Illustration, Column (JO)*. This column is divided as follows:

(1) *Figure Number, Column (10) (a)*. Indicates the figure number of the illustration in which the item is shown.

(2) *Item Number, Column (10) (b)*. Indicates the callout number used to reference the item in the illustration.

B-4. Special Information. a. Identifications of the usable-on codes for the pumps and the engine assemblies they are used on are included at the end of the description column, column (3) of this publication, and are:

A	LDS-465-2 Engine Assembly
B	LDS-465- 1A Engine Assembly
C	LD-465-1 Engine Assembly
D	LD-465-1C Engine Assembly
E	LDT-465-1C Engine Assembly
F	LDS-465- 1 Engine Assembly
G	LDS-427-2 Engine Assembly
Blank	Applicable to all pump assemblies

b. The basis of issue for authorized special tools, and test and support equipment is the number of end items of equipment supported and the number of maintenance personnel allocated to perform the required maintenance operations (such as, six of each tool for each 100 pumps supported).

c. Parts which require manufacture or assembly at a category higher than that authorized for installation will indicate in the source column the higher category.

d. Certain parts are supplied in parts kits and gasket sets. When a kit is composed of parts which are normally in more than one group, the kit will be listed in only special purpose kits section. Components of the kit which are not in that particular group will appear in their normal group listing with an appropriate reference to the kit. Component parts of a kit which have a Federal stock number and are source coded P may be procured as line items.

e. The following publications are the up-assembly of Pump, Fuel, Metering and Distributing, Assemblies 2910-1 16-8241, 2910-178-1185, 2910-759-5410, 2910-908-6320 and 2910-968-6317.

TM 9-2815-210-34P Direct support and general support maintenance repair parts and special tools list (including depot maintenance repair parts and special tools): Engine, diesel (multifuel): turbocharged, fuel injected, water cooled, 4-cylinder assembly (military models LD-465-1, 2815-239-5834, LG-465-1C, 2815-134-4830, LDT-465-1C, 2815-103-2642, LDS-465-1, 2815-075-0087, LDS-465-1A, 2815-239-5819, and LDS-465-2, 2815-808-8011 and clutches).

TM 9-2815-204-34P Direct support and general support maintenance repair parts and special tools list (including depot maintenance repair parts and special tools): Engine, diesel: with container liquid cooled, V-type, six cylinder (2815-022-6732) composed of: engine, diesel: (Detroit Diesel-GMC model 5063-5299, series 6V53) and container (8115-202-8589) engine, diesel: with container (2815-909-5949) composed of: engine, diesel: (Detroit Diesel-GMC model 5063-5398 series 6V53T) and container assembly (8115-999-5336).

f. Tables B-1 and B-2 are provided as a rapid index to all recoverable, direct exchange items and repair kits and sets contained in this manual. The items in table B- 1 are in FSN sequence and the items in table B-2 are listed in functional group sequence.

B-5. How to locate Repair Parts. a. When Federal stock number or reference number is unknown.

(1) *First.* Using the table of contents, determine the appropriate group, subgroup, or assembly group; i.e., fuel supply pump. governor; etc., within which the repair part belongs. This is necessary since illustrations are prepared for groups and subgroups, and listings are divided into the same groups.

(2) *Second.* Find the illustration covering the group, or subgroup, to which the repair part belongs.

(3) *Third.* Identify the repair part on the illustration and note the illustration figure and item number of the repair part.

(4) *Fourth.* Using the repair parts listing, find the group or subgroup, to which the repair part belongs and locate the illustration figure and item number noted on the illustration.

b. When Federal stock number or reference number is known:

(1) *First.* Using the index of Federal stock numbers and reference numbers find the pertinent Federal stock number or reference number. This index is in ascending FSN sequence followed by a list of reference numbers in ascending alphanumeric sequence, cross-referenced to the illustration figure number and item number.

(2) *Second.* Using the repair parts listing, find the group or subgroup, of the repair part and the illustration figure number and item number referenced in the index of Federal stock numbers and reference numbers.

B-6. Abbreviations

assy	assembly
dia.....	diameter
id.....	inside diameter
in.....	inch
IUE	issue until exhaust
lg.....	long
mtr	metering
NF.....	American Standard Firm
No.....	American Standard Taper Pipe
NPT	American Standard Taper Pipe Threads
od	outside diameter
pcs.....	pieces
qty.....	quantity
thk	thick
UNC.....	Unified National Coarse
UNF	Unified National Fine
w/.....	with
wd.....	wide

01843	American Bosch Division of B Arma Corp.
10001	Navel Ordnance Systems Comm
19204	Rack Island Arsenal
19207	Army Tank Automotive Commix
21335	Fafnir Bearing Company
21450	Ordnance Corps
24617	General Motors Corp.
30327	Imperial-Eastman Corp.
81348	Federal Specifications GSA
88044	Aeronautical Standards Group
96906	Military Standards

B-7. Federal Supply Codes for Manufacturers. The following is a list of Federal supply codes for manufacturers appearing in parentheses after the part number in the description column.

Table B-1. Recoverable and Direct Exchange Items

SMR	FSN	Part No. and Mfg Code	Description	Qty Inc.	Illustration	
					Fig No.	Item No.
XAHHH		10935261 (19207)	PUMP, FUEL, METERING AND DISTRI- BUTING.	1	B-1	15
XAHHH		10935261-2 (19207)	PUMP, FUEL, METERING AND DISTRI- BUTING.	1	B-1	15
XAHHH		11641906 (19207)	PUMP, FUEL, METERING AND DISTRI- BUTING.	1	B-1	15
PAHDL	2910-871-5435	10914599 (19207)	HEAD ASSEMBLY: Fuel Injection Pump.	1	B-4	16
PAFHH	2910-116-8241	10936264-2 (19207)	PUMP, FUEL, METERING AND DISTRI- BUTING: Assembly	1	B-1	
PAFHH	2910-178-1185	11641907 119207)	PUMP, FUEL, METERING AND DISTRI- BUTING: Assembly	1	B-1	
PAFHH	2910-759-6410	10935264 (19207)	PUMP, FUEL, METERING AND DISTRI- BUTING: Assembly	1	B-1	
PAHDL	2910-762-4623	11662498 (19207)	HEAD HYDRAULIC: Fuel Injection Pump.	1	B-4	16
PAHDL	2910-828-7167	11602722 (19207)	HEAD HYDRAULIC: Fuel Injection Pump.	1	B-1	16
PAHDL	2910-828-7176	11602721 (19207)	HEAD HYDRAULIC: Fuel Injection Pump.	1	B-4	16
PAFHH	2910-908-6320	10961116 (19207)	PUMP, FUEL, METERING AND DISTRI- BUTING: Assembly	1	B-1	
XAHHH		10951116 (19207)	PUMP, FUEL, METERING AND DISTRI- BUTING.	1	B-1	15
PAFHH	2910-968-6317	10935295 119207)	PUMP, FUEL, METERING AND DISTRI- BUTING.	1	B-1	

Table B-2. Repair Kits and Sets

SMR	FSN	Part No. and Mfg Code	Description	Function group	Illustration	
					Fig No.	Item No.
PAHZZ	2910-246-3997	11610356 (19207)	PARTSKIT, METERING AND DISTRIBUTING FUEL PUMP: Fuel Adjustment Enclosure	03	B-1	
PAHZZ	2910-433-2237	5704374 (19207)	PARTS KIT, METERING AND DISTRIBUTING FUEL PUMP: Hydraulic Head Lubrication Oil Duct Plug.	03	B-2	
PAHZZ	2910-194-4644	5704371 (19207)	PARTS KIT, METERING AND DISTRIBUTING FUEL PUMP: Operating Shaft	03	B-3	
PAHZZ	2910-252-5580	5704352 (19207)	PARTS KIT, METERING AND DISTRIBUTING FUEL PUMP: Governor and Linkage.	03	B-3	
PAHZZ	2910-405-4363	5704373 (19207)	PARTS KIT, METERING AND DISTRIBUTING FUEL PUMP: Fuel Density Compensator In- stallation.	03	B-3	
PAHZZ	2910-491-6836	5704377 (19207)	PARTS KIT, METERING AND DISTRIBUTING FUEL PUMP: Operating Shaft.	03	B-3	
PAHZZ	2910-786-5238	5702638 (19207)	SHIM SET: Fuel Injection Pump Governor Ad- justing.	03	B-3	
PAHZZ	2910-968-6318	5702685 (19207)	PARTS KIT, FUEL INJECTION PUMP: Governor and Linkage.	03	B-3	
PA HZZ	2910-489-5994	5704368 (19207)	PARTS KIT. METERING AND DISTRIBUTING FUEL PUMP: Supply Pump Inspection.	03	B-6	
PADZZ	2910-489-2557	5704372 (19207)	PARTS KIT, METERING AND DISTRIBUTING PUMP: Timing Device Housing.	03	B-7	
PAHZZ	2910-871-5431	5702661 (19207)	REPAIR KIT, FUEL INJECTION PUMP: Timing Device.	03	B-7	
PAHZZ	2910-472-1711	5704378 (19207)	SPRING SET: Timing Device Advance Unit.	03	B-7	
PAHZZ	2910-472-1709	5704379 (19207)	SPRING SET: Timing Device Advance Unit.	03	B-7	
PAHZZ	2910-192-9433	5704370 (19207)	SPRING SET: Timing Device Advance Unit.	03	B-7	
PAHZZ	2910-407-2618	5704369 (19207)	PARTS KIT. METERING AND DISTRIBUTING FUEL PUMP: Governor Weight and Spider.	03	B-9	
PAHZZ	2910-884-4807	5702663 (19207)	GASKET AND PREFORMED PACKING SET: Metering and Distributing Pump.	03		

Section II. REPAIR PARTS LIST

(1) Source maint. and recov code	(2) Federal stock number	(3) Description	(4) Unit of issue	(5) Qty. inc in unit	(6) 30 day DS maint. alw.			(7) 30 day GS maint. alw.			(8) 1 Yr alw per 100 equip/cntgcy planning	(9) Depot main alw per 100 equip	(10) Illustration		
					(a) 1-20	(b) 21-50	(c) 51-100	(a) 1-20	(b) 21-50	(c) 51-100			(a) Fig. No.	(b) Item No.	
		GROUP03- FUEL SYSTEM													
PA F HH	2910-759-5410	0301 -CARBURETOR. FUEL INJECTOR PUMP. FUEL, METERING AND DISTRIBUTING: assy 10935264 (19207).	CD	EA		*	*	*	*	*	*			B-1	
PA F HH	2910-908-6320	PUMP, FUEL METERING AND DISTRIBUTION: assy 10951115 (19207).	BF	EA		*	*	*	*	*	*			B-1	
PA F HH	2910-178-1185	PUMP. FUEL, METERING AND DISTRIBUTING: assy 11641907 (19207).	A	EA		*	*	*	*	*	*			B-1	
PA F HH	2910-116-8241	PUMP, FUEL. METERING AND DISTRIBUTING: assy 10935264-2 (19207).	E	EA		*	*	*	*	*	*			B-1	
PA F HH	2910-968-6317	PUMP. FUEL, METERING AND DISTRIBUTING: assy 10935295 (19207).	G	EA		*	*	*	*	*	*			B-1	
PA 0 ZZ	4730-289-5420	TEE, PIPE TO TUBE: compensator overflow 10914555 119207).	ABC	EA	1	*	*	*	*	*	*			B-1	1
PA 0 ZZ	4730-278-8368	INVERTED NUT TUBE: compensator overflow TEE (2), compensator overflow ELBOW (1) 81LB1-4 (30327).	ABC DEF	EA	3	*	*	*	*	*	*			B-1	2
MO 0 ZZ		TURING. PLASTIC: compensator overflow to overflow valve(fabricate from 4720-135-4424. 1 pc, 10.50 in. lg.) 11609976-5 (19207).	ABC DEF	EA	1									B-1	3
PA 0 ZZ	4720-135-4424	TUBING. PLASTIC: 11609976 119207)	ABC DEF	FT	V	*	*	*	*	*	*			B-1	
PA 0 ZZ	4730-882-8621	ELBOW, PIPE TO TUBE: compensator overflow (Furnished with COMPENSATOR - 2910-907-0665 and 2910-125-3797) 89LB1-4X1-8 (30327)	ABC DEF	EA	1	*	*	*	*	*	*			B-1	4
KF H ZZ		COVER: compensator fuel adjustment 11610344 (19207)	ABC DEF	EA	1									B-1	5
PA H ZZ	5340-598-3442	SEAL. METALLIC: No. 23, 2-strand, 24.00 in. lg., compensator fuel adjustment cover screws (1), compensator regulator valve sleeve (1) (furnished with COMPENSATOR 2910-907-0665 and 2910-125-3797) MS51938-2 (96906).	ABC DEF	EA	2				*	*	*			B-1	6
PA H ZZ	5305-247-7065	SCREW, CAP. HEXAGON HEAD: compensator to fuel injection pump (Used with COMPENSATOR 10951200)11641825-1 (19207).	ABC DEF	EA	4				*	*	*			B-1	7
PA H ZZ	5305-071-2238	SCREW, CAP HEXAGON HEAD: 1/4-20UNC-2A, 1.750 lg. compensator to injection pump (used with COMPENSATOR 109354391 MS90725-13 (96906).	F	EA	2				*	*	*			B-1	7
PA H ZZ	5310-682-5930	WASHER. LOCK: 1/4 id. 0.539 od. 0.094 thk, compensator or governor cover to fuel injection pump MS35340-44 (96906).		EA	4				*	*	*			B-1	8

(1) Source maint. and recov code	(2) Federal stock number	(3) Description	(4) Unit of issue	(5) Qty. inc in unit	(6) 30 day DS maint. alw.			(7) 30 day GS maint. alw.			(8) 1 Yr alw per 100 equip/ cntgcy plan ning	(9) Depot main alw per 100 equip	(10) Illustration	
					(a) 1-20	(b) 21-50	(c) 51-100	(a) 1-20	(b) 21-50	(c) 51-100			(a) Fig. No.	(b) Item No.
MO O ZZ		TUBING, PLASTIC: compensator fuel inlet tee to injection PUMP (fabricate from 4710-726-5459, 1 pc. 10.00 in. lg).	ABC DEF	EA	1								B-1	9
PA O ZZ	4710-726-5459	TURING, PLASTIC 10861278 (19207)	ABC DEF	FT	V	*	*	*	*	*	*		B-1	
PA O ZZ	4720-223-7016	HOSE ASSEMBLY NONMETALLIC: compensator fuel inlet tee (Used w/TEE 4730-764-2328) 10935237-3 (19207).	F	EA	1	*	*	*	*	*	*		B-1	9
PA H ZZ	4820-125-3797	COMPENSATOR, FUEL DENSITY: 11641870 (19207).	A	EA	1				*	*	*		B-1	10
PA H ZZ	2910-907-0665	COMPENSATOR, FUEL DENSITY: 10951200 (19207).	BCD EF	EA	1				*	*	*		B-1	10
PA H ZZ	5340-911-6754	CLAMP, LOOP: engine stop cable (Not used with COMPENSATOR 10935439) 10896235 119207).	BCD EF	EA	1				*	*	*		B-1	11
PA O ZZ	4730-764-2328	TEE. PIPE TO TUBE: compensator fuel inlet fuse w/HOSE 4720-078-9783 and 4720-223-7016) 9403098 (19207).	F	EA	1	*	*	*	*	*	*		B-1	12
PA O ZZ	4730-900-6319	TEE. PIPE TO TUBE: compensator fuel inlet (furnished with COMPENSATOR 2910-907-0665 and 2910-125-3797) 10951183 (19207):	ABC DEF	EA	1	*	*	*	*	*	*		B-1	12
PA O ZZ	4730-288-9391	INVERTED NUT, TUBE: compensator fuel inlet tee 81LB3-8 (303271).	ABC DEF	EA	2	*	*	*	*	*	*		B-1	13
PA H ZZ	2910-310-6556	GASKET: fuel density compensator or governor housing cover to fuel injection pump 7383459 (19207).	ABC DE FG	EA	1				*	*	*		B-1	14
XA H HH		PUMP. FUEL. METERING AND DISTRIBUTING: 11641906 (19207).	A	EA	1								B-1	15
XA H HH		PUMP, FUEL, METERING AND DISTRIBUTING: 10951116 (19207).	BF	EA	1								B-1	15
XA H HH		PUMP, FUEL, METERING AND DISTRIBUTING: 10935261 (19207).	CD	EA	1								B-1	15
XA H HH		PUMP, FUEL, METERING AND DISTRIBUTING: 10935261-2 (19207).	E	EA	1								B-1	15
KF H ZZ		SEAL., WIRE: operating lever assy SE:1006 (01843).		EA	1				See SET 2910-884-4807				B-1	16
PA O ZZ	4730-203-2866	ELBOW, PIPE TO TUBE: fuel supply pump outlet 10951182 (19207).		EA	1	*	*	*	*	*	*		B-1	17
PA O ZZ	4730-278-3676	ELBOW. PIPE TO TUBE: fuel supply pump outlet (use w/HOSE 4720-078-7024 and HOSE 4720-081-4210; see TM9-2815-210-34P and TM9-2815-204-35P) MS20822-6P. (96906)	FG	EA	1	*	*	*	*	*	*		B-1	17
P A O ZZ	4730-288-9391	INVERTED NUT, TUBE: fuel supply pump outlet elbow 81LB3-38 (30327)		EA	1	*	*	*	*	*	*		B-1	24
PA O ZZ	4730-851-0173	ELBOW, PIPE TO TUBE: fuel supply pump inlet 9402799 (19207).	ACD EG	EA	1	*	*	*	*	*	*		B-1	18

(1) Source maint. and recov code	(2) Federal stock number	(3) Description	(4) Unit of issue	(5) Qty. inc in unit	(6) 30 day DS maint. alw.			(7) 30 day GS maint. alw.			(8) 1 Yr alw per 100 equip/ cntgcy plan ning	(9) Depot main alw per 100 equip	(10) Illustration	
					(a) 1-20	(b) 21-50	(c) 51-100	(a) 1-20	(b) 21-50	(c) 51-100			(a) Fig. No.	(b) Item No.
PA O ZZ	4730-882-8624	ELBOW. PIPE TO TUBE: fuel supply pump to flame heater tube 10951187 (19207)	BF	EA	1	*	*	*	*	*	*	B-1	18	
PA O ZZ	4730-278-8368	INVERTED NUT, TUBE: fuel supply pump to flame heater tube 81LB1-4 (30327)		EA	1	*	*	*	*	*	*	B-1	23	
PA O ZZ	4730-044-4040	ELBOW. PIPE: fuel pump inlet 444040 (21450)	B	EA	1	*	*	*	*	*	*	B-1	19	
PA O ZZ	4730-882-8624	ELBOW, PIPE TO TUBE: fuel supply pump to flame heater tube 10951187 (19207)	AF	EA	1	*	*	*	*	*	*	B-1	19	
PA O ZZ	4730-278-8368	INVERTED NUT. TUBE: fuel supply pump to flame heater tube 81LB1-4 (30327)		EA	1	*	*	*	*	*	*	B-1	23	
PA O ZZ	4730-843-4740	ADAPTER. STRAIGHT. PIPE: fuel supply pump to flame heater tube 10951317 (19207).	CD EG	EA	1	*	*	*	*	*	*	B-1	20	
PA O ZZ	4730-278-8368	INVERTED NUT. TUBE: fuel supply pump to flame heater tube 81LB1-4 (30327).		EA	1	*	*	*	*	*	*	B-1	23	
PA O ZZ	4730-882-8621	ELBOW. PIPE TO TUBE: injection pump overflow elbow 89LB1-4X1-8 (30327).	G	EA	1	*	*	*	*	*	*	B-1	21	
PA O ZZ	4730-278-8368	INVERTED NUT, TUBE: injection pump overflow elbow 81LB1-4 (30327).		EA	1	*	*	*	*	*	*	B-1	22	
PA O ZZ	4730-278-3676	ELBOW. PIPE TO TUBE: fuel pump overflow and fuel return MS20822-6B (96906).	A	EA	1	*	*	*	*	*	*	B-1	25	
PA O ZZ	4730-203-2866	ELBOW, PIPE TO TUBE: fuel pump overflow and return 10951182 119207).	BCD EFG	EA	1	*	*	*	*	*	*	B-1	25	
PA O ZZ	4730-851-0173	ELBOW. PIPE TO TUBE: fuel pump overflow and fuel return (use with HOSE 4720-081-42111; see TM9-2815-210-34P)9402799 (19207).	G	EA	1	*	*	*	*	*	*	B-1	25	
PA O ZZ	4730-288-9391	INVERTED NUT, TUBE : fuel pump overflow and return elbow 81LB3-8 (30327).		EA	1	*	*	*	*	*	*	B-1	26	
PA O ZZ	4730-901-8129	ELBOW, PIPE TO TUBE: hydraulic head fuel inlet 10951181 (19207).		EA	1	*	*	*	*	*	*	B-1	27	
PA O ZZ	4730-851-0173	ELBOW. PIPE TO TUBE: hydraulic head fuel inlet fuse with HOSE 4720-223-7016 and COMPENSATOR 10935439) 9402799 (19207).	F	EA	1	*	*	*	*	*	*	B-1	27	
PA O ZZ	4730-851-0173	ELBOW. PIPE TO TUBE: hydraulic head fuel inlet (use with HOSE 2910-081-4211; see TM9-2815-204-34P) 9402799 (19207).	G	EA	1	*	*	*	*	*	*	B-1	27	
PA O ZZ	4730-288-9391	INVERTED NUT, TUBE: hydraulic head fuel inlet elbow 81LB3-8 (30327).		EA	1	*	*	*	*	*	*	B-1	28	
KF H ZZ		SLEEVE: compensator regulator valve screw (furnished with COMPENSATOR 11610343 (19207).	ABC DEF	EA	1			See KIT 2910-246-3997				B-1	29	

(1) Source maint. and recov code	(2) Federal stock number	(3) Description	(4) Unit of issue	(5) Qty. inc in unit	(6) 30 day DS maint. alw.			(7) 30 day GS maint. alw.			(8) 1 Yr alw per 100 equip/ cntgcy plan ning	(9) Depot main alw per 100 equip	(10) Illustration	
					(a) 1-20	(b) 21-50	(c) 51-100	(a) 1-20	(b) 21-50	(c) 51-100			(a) Fig. No.	(b) Item No.
PA H ZZ	5365-431-6652	SPACER, SLEEVE: compensator fuel adjustment F cover (use with COMPENSATOR 10935439) 11610388 (19207).	EA	2				*	*	*			B-1	30
XA H ZZ		COVER: governor housing G CV9032C (01843).	EA	1									B-1	31
PA H ZZ	2910-246-3997	PARTS KIT, METERING AND DISTRIBUTING ABC FUEL PUMP: fuel adjustment closure DEF 11610356 (19207).											B-1	
KF H ZZ		Composed of: 1 COVER: 11610344 (19207)	ABC DEF										B-1	5
PA H ZZ	5340-598-3442	2 SEAL. METALLIC: MS51938-2 (96906).	ABC DEF										B-1	6
PA H ZZ	5305-247-7065	2 SCREW CAP, HEXAGON HEAD: 11641825-1 (19207)	ABC DEF										B-1	7
KF H ZZ		1 SLEEVE: 11610343 (19207) (furnished with COMPENSATOR).	ABC DEF										B-1	29
PA H ZZ	5365-431-6652	1 SPACER. SLEEVE: 11610388 (19207) (used with COMPENSATOR 2910-017-9776).	F										B-1	30
PA H ZZ	5306-816-5803	BOLT. MACHINE: governor cover to governor G housing 7383456 (19207).	EA	4				*	*	*			B-1	32
XA H ZZ		FUEL SUPPLY PUMP AND OPERATING LEVER SCREW: timing window cover to injection pump BCD housing SC27-20BL (01843).	EA	2									B-2	1
PA H ZZ	5310-582-5965	WASHER, LOCK: ¼ id, 0.489 od, 0.062 thk, timing window cover or solenoid assembly to injection pump housing (2), operating lever clamping bolt (1), fuel supply to injection housing (2) MS35338-44 (96906).	EA	5				*	*	*			B-2	2
PF H ZZ	2910-103-8845	COVER: fuel injection pump timing window BCD CV9018 (01843).	EA	1				*	*	*			B-2	3
PA H ZZ	5330-419-9467	GASKET: fuel shutoff or timing window cover solenoid to injection pump housing 11662856 (19207).	EA	1				*	*	*			B-2	4
PA H ZZ	5305-543-4925	SCREW. MACHINE: No. 10-24NC-2A, 7/8 lg. control unit retainer to injection pump housing MS35265-66 (96906).	EA	2				*	*	*			B-2	5
PA H ZZ	5310-045-3296	WASHER. LOCK: No. 10 id, 0.334 od, 0.047 thk, control unit to retainer injection pump housing MS35338-43 (96906).	EA	2				*	*	*			B-2	6
PA H ZZ	2910-036-4161	RETAINER: control unit RN9011 (01843).	EA	1				*	*	*			B-2	7
PA H ZZ	2910-751-9211	CLIP, RETAINING: control rod PN1122 (01843).	EA	1				*	*	*			B-2	8
PA H ZZ	2910-936-7780	CONTROL. UNIT: fuel injection 11662500 (19207).	A EA	1				*	*	*			B-2	9

(1) Source maint. and recov code	(2) Federal stock number	(3) Description	(4) Unit of issue	(5) Qty. inc in unit	(6) 30 day DS maint. alw.			(7) 30 day GS maint. alw.			(8) 1 Yr alw per 100 equip/ cntgcy plan ning	(9) Depot main alw per 100 equip	(10) Illustration	
					(a) 1-20	(b) 21-50	(c) 51-100	(a) 1-20	(b) 21-50	(c) 51-100			(a) Fig. No.	(b) Item No.
PA H ZZ	2910-907-0674	CONTROL UNIT: fuel injection pump BCD 10947152 (19207)	EA	1				*	*	*			B-2	9
PA H ZZ	2910-871-5437	CONTROL UNIT: fuel injection pump EF 10914588 (19207).	EA	1				*	*	*			B-2	9
PA H ZZ	5315-217-3457	PIN, STRAIGHT, HEADED: control unit plunger sleeve G PN906 (01843).	EA	1				*	*	*			B-2	10
PA H ZZ	2910-292-1464	PACKING, PREFORMED: control unit assembly to injection pump housing 10914594 (19207).	EA	1				*	*	*			B-2	11
PA H ZZ	5310-491-0319	NUT. PLAIN, HEXAGON: injection pump driven gear and coupling half to pump shaft 10898716 (19207).	EA	1				*	*	*			B-2	12
PA H ZZ	5310-167-0680	WASHER, LOCK: 9/16 id, 0.971 od, 0.141 thk, injection pump driven gear and coupling half to pump shaft MS35338-49 (96906).	EA	1				*	*	*			B-2	13
PA H ZZ	2910-908-6324	VALVE, OVERFLOW: ABC 10947157 (19207).	EA	1				*	*	*			B-2	14
PA H ZZ	2910-937-7833	VALVE ASSEMBLY, METERING: (use with SUPPLY PUMP 4320-999-2276) VA9053A (01843).	EA	1				*	*	*			B-2	14
PA H ZZ	2910-871-5440	VALVE. OVERFLOW: G 7748843 (19207).	EA	1				*	*	*			B-2	14
KF H ZZ		PIN: lubrication oil duct, injection pump housing F PN9052 (01843).	EA	1				See KIT 2910-433-2237					B-2	15
PA H ZZ	5330-292-1463	PACKING, PREFORMED: lubrication oil duct, injection pump housing FG GA1012 (01843).	EA	1				*	*	*			B-2	16
PA H ZZ	5366-245-5420	SPACER, RING: lubrication oil duct, injection pump housing FG 7336789 (19207).	EA	1				*	*	*			B-2	17
KF H ZZ		SCREW, SEALING: lubrication oil duct injection pump housing F SC9052 (01843).	EA	1				See KIT 2910-4332237					B-2	18
PA H ZZ	2910-301-8733	FILTER, ELEMENT: fluid lubrication oil duct, injection pump housing FG FE901 (01843).	EA	1				*	*	*			B-2	19
PA H ZZ	4730-585-2779	BOLT, FLUID PASSAGE: lubrication oil duct, injection pump housing FG SC903 (01843).	EA	1				*	*	*			B-2	20
PA H ZZ	5306-952-8456	BOLT, INTERNAL WRENCHING: operating stop lever BCD 10935304 (19207).	EA	1				*	*	*			B-2	21
PA H ZZ	2910-785-6353	LEVER, STOP: fuel injection BCD 7383419 (19207).	EA	1				*	*	*			B-2	22
PA H ZZ	5365-263-5869	RING, RETAINING: 0.37 5 dia, 0.025 thk, operating lever shaft BCD MS16624-37 (96906).	EA	1				*	*	*			B-2	23
XA H ZZ		COVER: operating shaft stop Lever A CV9050 (01843).	EA	1									B-2	24

(1) Source maint. and recov code	(2) Federal stock number	(3) Description	(4) Unit of issue	(5) Qty. inc in unit	(6) 30 day DS maint. alw.			(7) 30 day GS maint. alw.			(8) 1 Yr alw per 100 equip/ cntgcy plan ning	(9) Depot main alw per 100 equip	(10) Illustration	
					(a) 1-20	(b) 21-50	(c) 51-100	(a) 1-20	(b) 21-50	(c) 51-100			(a) Fig. No.	(b) Item No.
XA H ZZ		COVER: operating shaft stop lever CV79241 (01843). BCD EFG	EA	1									B-2	24
PA H ZZ	5310-193-7574	WASHER, LOCK: stop lever cover to operating shaft be FFW100 (01843).	EA	1				*	*	*			B-2	25
PA H ZZ	5306-810-0053	BOLT, MACHINE: stop lever cover to operating shaft bring 7383465 (19207).	EA	1				*	*	*			B-2	26
PA H ZZ	2910-492-8143	LEVER ASSEMBLY, OPERATING: 11662496 (19207).	EA	1				*	*	*			B-2	27
PA H ZZ	2910-968-6320	LEVER ASSEMBLY, OPERATING: 10933 (19207).	EA	1				*	*	*			B-2	27
PA H ZZ	2910-871-5429	LEVER ASSEMBLY. OPERATING: (use with PUMP 7748899 only) 10910348 (19207).	EA	1				*	*	*			B-2	27
XA H ZZ		BOLT. MACHINE: operating lever clamping SC9043 (01843).	EA	1									B-2	28
XA H ZZ		BOLT, MACHINE: operating lever clamping SC7961 (01843).	EA	1									B-2	28
XA H ZZ		BOLT, MACHINE: operating ver damping (use with PUMP 7748899 only) SC1769 (01843).	EA	1									B-2	28
XA H ZZ		LEVER, OPERATING: LE90117 (01843).	EA	1									B2	29
XA H ZZ		LEVER, OPERATING: LE90102 (01843).	EA	1									B2	29
XA H ZZ		LEVER, OPERATING: (use with PUMP 7748899 only)LE9083 (01843).	EA	1									B-2	29
PA H ZZ	5310-361-9835	NUT, LOCK: operating lever damping bolt NT8-8BL (01843).	EA	1				*	*	*			B-2	30
PA H ZZ	5310-665-9484	NUT. PLAIN, CASTELLATED: operating lever clamping bolt (use with PUMP 7748899) 43N71918-10 (10001).	EA	1				*	*	*			B-2	30
PA H ZZ	5305-964-0560	SCREW, CAP, HEXAGON HEAD: 1/4-20UNC-2A 1 3/4 lg, supply pump to injection pump housing MS51095-311 (96906).	EA	2				*	*	*			B-2	31
PA H ZZ	2910-871-5439	ROD ASSEMBLY: fuel shutoff 10914598 (19207).	EA	1				*	*	*			B-2	32
PA H ZZ	5330-190-4211	GASKET: fuel shutoff rod assembly to timing window cover 105463 (24617).	EA	1				*	*	*			B-2	33
PA H ZZ	2990-977-2591	WIRE: control unit retainer to injection pump housing (1 pc, 17.00 in. lg) W1763 (01843).	EA	1				*	*	*			B-2	34
PA H ZZ	4730-879-1663	TEE PIPE TO TUBE: advance housing to oil hose FI1286 (01843).	EA	1				*	*	*			B-2	35
PA H ZZ	4720-879-1676	HOSE ASSEMBLY, NONMETALLIC: advance housing to injection pump housing 7748847 (19207).	EA	1				*	*	*			B-2	36
PA H ZZ	4730-903-6645	ELBOW, PIPE TO TUBE: injection pump housing to oil hose 10935557 (19207).	EA	1				*	*	*			B-2	37

(1) Source maint. and recov code	(2) Federal stock number	(3) Description	(4) Unit of issue	(5) Qty. inc in unit	(6) 30 day DS maint. alw.			(7) 30 day GS maint. alw.			(8) 1 Yr alw per 100 equip/ cntgcy plan ning	(9) Depot main alw per 100 equip	(10) Illustration	
					(a) 1-20	(b) 21-50	(c) 51-100	(a) 1-20	(b) 21-50	(c) 51-100			(a) Fig. No.	(b) Item No.
PA H ZZ	2910-313-2617	GASKET: fuel supply pump to injection pump housing 7748850 (19207).	EA	1				*	*	*			B-2	38
PA H ZZ	4320 0-6322	PUMP, ROTARY, POWER DRIVEN: fuel injection pump 10947163 (19207).	A EA	1				*	*	*			B-2	39
PA H ZZ	4320-908-6321	PUMP, ROTARY. POWER DRIVEN: fuel injection pump supply 10947658 (19207).	BCD EFO EA	1				*	*	*			B-2	39
PA H ZZ	4320-999-2276	PUMP, ROTARY: injection pump supply (use on PUMP 2910-017-9778 until injection pumps are exhausted) SGB25C19 (01843).	F EA	1				*	*	*			B-2	39
KF H ZZ		SEAL, WIRE: stop lever cover to operating shaft bearing SE1006 (01843).	EA	1							See SET 2910-884-4807		B-2	40
XA H ZZ		BRACKET: Throttle control return spring 10938294 (19207).	B EA	1	B-2	41								
PA H ZZ	5305-405-2002	SCREW, CAP, SOCKET HEAD: solenoid assembly to injection pump housing 11662504 (19207).	A EA	2				*	*	*			B-2	42
PA H ZZ	2990-977-2591	WIRE: solenoid to injection pump housing screw (1 pc, 17.00 in. lg) WI763 (01843).	A EA	2				*	*	*			B-2	43
PA H ZZ	2910-421-3941	HOUSING ASSEMBLY, SOLENOID FUEL SHUTOFF: 11602499 (19207).	A EA	1				*	*	*			B-2	44
PA H ZZ	5935-987-1079	SHELL, BLACKOUT STOP: solenoid terminal 7982399 (19207).	EA	1				*	*	*			B-2	45
PA H ZZ	5310-045-5207	WASHER, FLAT: 0.129 id, 0.438 od, 0.094 thk, solenoid terminal shell MS15795-908 (96906).	EA	1				*	*	*			B-2	46
PA H ZZ		NUT, PLAIN, HEXAGON: solenoid terminal spell 11601150 (19207).	EA	1				*	*	*			B-2	47
PA H ZZ	2910-433-2237	PARTS KIT. METERING AND DISTRIBUTING FUEL PUMP: hydraulic head lubrication oil duct plug 5704374 (19207)	F EA					*	*	*			B-2	
KF H ZZ		Composed of:											B-2	16
PA H ZZ	5330-292-1463	1 PIN: PN9062 (01843)											B-2	16
PA H ZZ		1 PACKING, PREFORMED: GA1012 (01843).											B-2	17
KF H FF	5365-246-5420	1 SPACER. RING: 7336789 (19207)											B-2	18
		1 SCREW, SEALING: SC9052 (01843)											B-2	
		GOVERNOR HOUSING AND ASSOCIATED PARTS												
KF H ZZ		GASKET: governor housing to fuel injection pump housing GA9029 (01843).	EA	1							See SET 2910-844-4807		B-3	1
KF H ZZ		SLEEVE ASSEMBLY: SV9028A (01843).	A EA	1							See KIT 2910-252-5580		B-3	2

(1) Source maint. and recov code	(2) Federal stock number	(3) Description	(4) Unit of issue	(5) Qty. inc in unit	(6) 30 day DS maint. alw.			(7) 30 day GS maint. alw.			(8) 1 Yr alw per 100 equip/ cntgcy plan ning	(9) Depot main alw per 100 equip	(10) Illustration	
					(a) 1-20	(b) 21-50	(c) 51-100	(a) 1-20	(b) 21-50	(c) 51-100			(a) Fig. No.	(b) Item No.
KF H ZZ		SLEEVE ASSEMBLY: 7748546 (19207).	BCD EFG	EA	1								B-3	2
PA H ZZ	2910-762-4590	LEVER ASSEMBLY: fulcrum 11662502 (19207).	A	EA	1				*	*	*		B-3	3
PA H ZZ	2910-999-547	LEVER ASSEMBLY: fulcrum 10947544 (19207).	BEF	EA	1				*	*	*		B-3	3
PA H ZZ	2910-411-8312	LEVER ASSEMBLY: fulcrum 10947545 (19207).	GD	EA	1				*	*	*		B-3	3
PA H ZZ	2910-235-4791	LEVER ASSEMBLY: fulcrum 10947543 119207).	G	EA	1				*	*	*		B-3	3
KF H ZZ		CAM. TORQUE: smoke limit 10885781 (19207).		EA	1								B-3	4
XA H ZZ		LEVER. FULCRUM: LE90119A (01843).	ABC DEF	EA	1								B-3	5
XA H ZZ		LEVER. FULCRUM: LE9084A (01843).	G	EA	1								B-3	6
PA H ZZ	5310-582-5965	WASHER. LOCK: 1/4. id, 0.489 od. 0.062 thk smoke limit cam and control rod pine screw to fulcrum lever MS35338-44 (96906).		EA	1				*	*	*		B-3	6
PA H ZZ	5310-361-9835	NUT, LOCK: smoke limit cam and control rod pin screw NT8-8BL (01843).		EA	1				*	*	*		B-3	7
PA H ZZ	5305-116-1613	SETSCREW: fulcrum lever droop 589586 (21450).	ABE FG	EA	1				*	*	*		B-3	8
KF H ZZ		SCREW: control rod SC9037 (01843).	ABC DEF	EA	1								B-3	9
KF H ZZ		SCREW: control rod SC8814 (01843).	G	EA	1								B-3	9
KF H ZZ		WASHER, SPACING: control rod spring WA1983 (01843).	A	EA	1								B-3	10
XA H ZZ		NUT: control rod NT1239 (01843).	ABC DEF	EA	1								B-3	11
XA H ZZ		ROD ASSEMBLY, CONTROL: fulcrum lever to control unit RD7049A (01843).	ABC DEF	EA	1								B-3	12
PA H ZZ	2910-936-5349	ROD, INJECTION PUMP: fulcrum lever to control unit RD9045A (01843).	G	EA	1				*	*	*		B-3	12
PA H ZZ	2910-751-9211	CLIP. RETAINING: control rod PN1122 (01843).	A	EA	1				*	*	*		B-3	13
XA H ZZ		WASHER: control rod adjusting WA1807 (01843)	ABC DEF	EA	1								B-3	14
KF H ZZ			ABC	EA	1								B-3	15
KF H ZZ			DEF	EA	1								B-3	15
XA H ZZ		PLATE: governor oil baffle BA906 (01843).	A	EA	1								B-3	16
XA H ZZ		PLATE: governor oil baffle BA902 (01843).	BCD EF	EA	1								B-3	16

(1) Source maint. and recov code	(2) Federal stock number	(3) Description	(4) Unit of issue	(5) Qty. inc in unit	(6) 30 day DS maint. alw.			(7) 30 day GS maint. alw.			(8) 1 Yr alw per 100 equip/ cntgcy plan ning	(9) Depot main alw per 100 equip	(10) Illustration	
					(a) 1-20	(b) 21-50	(c) 51-100	(a) 1-20	(b) 21-50	(c) 51-100			(a) Fig. No.	(b) Item No.
XA H ZZ		PLATE: governor oil baffle BA904 (01843).	G	EA	1								B-3	16
KF H ZZ		SPRING: torque link SP9049 (01843).	A	EA	1		See KIT 2910-252 5580						B-3	17
PA H ZZ	5305-362-7079	SCREW: governor housing to injection pump housing (3), governor end cap to governor housing (2) SC1140 (01843).		EA	5			*	*	*			B-3	18
PA H ZZ	2990-977-2591	WIRE, BEARING PLATE: governor housing to injection pump housing screws (1). governor end capscrew (1), bearing plate retaining screws (2) (4 pcs, 17.00 in. lg)W1763 (01843).		EA	4			*	*	*			B-3	19
XA H ZZ		HOUSING: governor HG9098 101843).	A	EA	1								B-3	20
XA H ZZ		HOUSING, GOVERNOR: HG9079 (01843).	BCD EFG	EA	1								B-3	20
PA H ZZ	2910-836-7316	SPRING, HELICAL, COMPRESSION: governor, inner 10951113 (19207).	A	EA	1			*	*	*			B-3	21
PA H ZZ	2990-850-3260	SPRING, HELICAL, COMPRESSION: governor, inner 10923499 (19207).	BCD FG	EA	1			*	*	*			B-3	21
PA H ZZ	5360-081-5977	SPRING, HELICAL, COMPRESSION: governor, inner 11668460 (19207).	E	EA	1			*	*	*			B-3	21
PA H ZZ	2990-830-3882	SPRING, HELICAL, COMPRESSION: governor, outer SP7951-13 (01843).	E	EA	1			*	*	*			B-3	22
PA H ZZ	5340-930-5140	SPRING, HELICAL, COMPRESSION; governor, outer 11588685 (19207).	ABC DFG	EA	1			*	*	*			B-3	22
KF H ZZ		SPACER: adjusting, outer 10.020 thk) 7748556 (19207).		EA	1		See SET 2910-786-5238						B-3	23
KF H ZZ		SPACER: adjusting, outer 10.042 thk) 7748651 (19207).		EA	1		See SET 2910-786-5238						B-3	23
KF H ZZ		SPACER: adjusting, outer (0.068 thk) 7748652 (19207).		EA	1		See SET 2910-786-5238						B-3	23
KF H ZZ		SPACER: adjusting, outer (0.083 thk) 7748553 (19207).		EA	1		See SET 2910-786-5238						B-3	23
KF H ZZ		SPACER: adjusting, outer (0.156 thk) 7748554 (19207).		EA	1		See SET 2910-786-5238						B-3	23
KF H ZZ		SPACER: adjusting, outer (0.030 thk) 7748555 (19207).		EA	1		See SET 2910-786-5238						B-3	23
KF H ZZ		SPACER: adjusting, inner (0.020 thk) 7748535 (19207).		EA	1		See SET 2910-786-5238						B-3	24
KF H ZZ		SPACER: adjusting, inner (0.042 thk) 7748536 (19207).		EA	1		See SET 2910-786-5238						B-3	24
KF H ZZ		SPACER: adjusting, inner (0.058 thk) 7748537 (19207).		EA	1		See SET 2910-786-5238						B-3	24
KF H ZZ		SPACER: adjusting, inner (0.083 thk) 7748538 (19207).		EA	1		See SET 2910-786-5238						B-3	24

(1) Source maint. and recov code	(2) Federal stock number	(3) Description	(4) Unit of issue	(5) Qty. inc in unit	(6) 30 day DS maint. alw.			(7) 30 day GS maint. alw.			(8) 1 Yr alw per 100 equip/ cntgcy plan ning	(9) Depot main alw per 100 equip	(10) Illustration	
					(a) 1-20	(b) 21-50	(c) 51-100	(a) 1-20	(b) 21-50	(c) 51-100			(a) Fig. No.	(b) Item No.
KF H ZZ		SPACER: adjusting, inner (0.177 thk) 7748539 (19207).	EA	1			See SET 2910-786-5238						B-3	24
KF H ZZ		SPACER: adjusting, inner (0.276 thk) 7748540 (19207).	EA	1			See SET 2910-786 5238						B-3	24
PA H ZZ	5330-640-9587	GASKET: governor housing end cap GA902 (01843).	EA	1				*	*	*			B-3	25
XA H ZZ		CAP: governor housing end CP901 (01843).	EA	1									B-3	26
XA H ZZ		SCREW: governor housing to injection pump housing SC1960 (01843).	EA	2									B-3	27
KF H ZZ		PIN ASSEMBLY: bracket pivot 7748545 (19207).	EA	1			See KIT 2910-252-5580 and 2910-968-6318						B-3	28
PA H ZZ	5330-406-7316	GASKET: operating shaft bearing to governor housing 11610208 (19207).	EA	1				*	*	*			B-3	29
KF H ZZ		PIN, LOCKING: operating shaft PN1258 (01843).	EA	2			See KIT 2910-252-5580						B-3	30
KF H ZZ		WASHER: operating shaft WA1802-1 (01843).	EA	2			See KIT 2910-252-5580						B-3	31
KF H ZZ		WASHER: operating shaft WA1802-3 (01843).	EA	2			See KIT 2910-252-5580						B-3	32
KF H ZZ		SHAFT ASSEMBLY: operating SH9095A (01843).	EA	1			See KIT 2910-194-4644						B-3	33
KF H ZZ		SHAFT ASSEMBLY: operating SH9083A (01843).	BCD EFG	EA	1		See KIT 2940-491-6836						B-3	33
PA H ZZ	5330-310-6659	GASKET: operating shaft GA76195 (01843).	EA	1				*	*	*			B-3	34
PA H ZZ	5360-785-6345	SPRING, HELICAL, TORSION: operating shaft 7383472 (19207).	EA	1				*	*	*			B-3	36
PA H ZZ	5305-263-8374	SCREW, SET: high speed adjusting FFS103 TYPE2 STYLE3 (81348).	EA	1				*	*	*			B-3	36
PA H ZZ	5310-768-0319	NUT, PLAIN, HEXAGON: 1/4.-28UNF-28, high speed adjusting MS51968-2 (96906).	EA	1				*	*	*			B-3	37
KF H ZZ		BEARING: operating shaft 11662496 (19207).	A	EA	1		See KIT 2910-194-4644						B-3	38
PA H ZZ	2910-871-5434	BEARING, OPERATING SHAFT: 7748821 (19207).	BCD EFG	EA	1			*	*	*			B-3	38
PA H ZZ	5310-599-5616	WASHER. FLAT: bearing plate screw GA7616 (01843).	EA	4				*	*	*			B-3	39
PA H ZZ	5305-543-4302	SCREW, MACHINE: 1/4.-20UNC-2A. 1/2 lg, operating shaft bearing to governor housing MS35265-79 (96906).	EA	4				*	*	*			B-3	40
PA H ZZ	5310-879-1677	NUT, SLEEVE: idle speed adjusting 7748609 (19207).	EA	1				*	*	*			B-3	41
PA H ZZ	5305-962-8458	SCREW, SET: idle speed adjusting 7748533 (19207).	EA	1				*	*	*			B-3	42
XF H ZZ		PLATE ASSEMBLY, SPRING: PL9055A (01843).	A	EA	1		See KIT 2910-194-4644						B-3	43

(1) Source maint. and recov code	(2) Federal stock number	(3) Description	(4) Unit of issue	(5) Qty. inc in unit	(6) 30 day DS maint. alw.			(7) 30 day GS maint. alw.			(8) 1 Yr alw per 100 equip/ cntgcy plan ning	(9) Depot main alw per 100 equip	(10) Illustration		
					(a) 1-20	(b) 21-50	(c) 51-100	(a) 1-20	(b) 21-50	(c) 51-100			(a) Fig. No.	(b) Item No.	
PA H ZZ	2910-786-0193	PLATE ASSEMBLY: spring 738473 (19207).	BCD EFG	EA	1				*	*	*			B-3	43
PA H ZZ	2910-492-8142	LINK ASSEMBLY, TORQUE: LK9016A (01843).	A	EA	1				*	*	*			B-3	44
KF H ZZ		WASHER, SPRING: fuel control stop WA886 (01843).	A	EA	1				See KIT 2910-405-4363					B-3	45
KF H ZZ		WASHER, SPACING: fuel control top WA1797 (01843).	A	EA	2				See KIT 2910-405-4363					B-3	46
XA H ZZ		STOP, FUEL CONTROL: 11641873 (19207).	A	EA	1									B-3	47
KF H ZZ		PIN, COTTER: fuel control stop PN2-10BL (01843).	A	EA	1				See KIT 2910-405-4363					B-3	48
PA F ZZ	4730-057-5555	PLUG, PIPE: 3/8-18NPT, governor housing - MS49005-6 (96906).		EA	1	*	*	*	*	*	*			B-3	49
PA H ZZ	5310-582-5965	WASHER, LOCK: 1/4 id, 0.489 od, 0.062 thk, plate and bridge assembly to governor housing MS35338-44 (96906).	G	EA	2				*	*	*			B-3	50
PA H ZZ	5310-582-5965	WASHER, LOCK: 1/4 id, 0.489 od, 0.062 thk, governor housing to injection pump housing (5), governor end cap to governor (2)MS35338-44 (96906).		EA	7				*	*	*			B-3	50
PA H ZZ	5305-362-7079	SCREW: plate and bridge ably to governor housing SC1140 (01843).	G	EA	2				*	*	*			B-3	51
PA H ZZ	5310-515-3030	WASHER, FLAT: plate and bridge assembly to governor housing 5153030 (19204).	G	EA	2				*	*	*			B-3	52
PA H ZZ	2910-033-5249	BRIDGE ASSEMBLY, STOP PLATE: governor 10947542 (19207).	G	EA	1				*	*	*			B-3	53
XA H ZZ		WASHER: control rod 7748547 (19207).	G	EA	1									B-3	54
KF H ZZ		PIN, COTTER: 137128 (21450).	G	EA	1				See KIT 2910-968-6318					B-3	55
PA H ZZ	2910-236-4791	LEVER ASSEMBLY: governor fulcrum 10947543 (19207).	G	EA	1				*	*	*			B-3	56
PA H ZZ	5310-361-9935	NUT, LOCK: droop screw to fulcrum lever NT8-8BL (01843).	G	EA	2				*	*	*			B-3	57
PA H ZZ	2910-194-4644	PARTS KIT, METERING AND DISTRIBUTING FUEL PUMP: operating shaft 5704371 (19207).	A	EA	1				*	*	*			B-3	
KF H ZZ		Composed of: 1 SHAFT ASSEMBLY: SH9095A (01843)												B-3	33
PA H ZZ	5360-785-6345	1 SPRING, HELICAL, TORSION: 7383472 (19207).												B-3	35
PA H ZZ	5305-263-8374	1 SCREW, SET: FFS103 TYPE2 STYLE2 (81348)												B-3	36
PA H ZZ	5310-768-0319	1 NUT, PLAIN, HEXAGON: MS51968-2 (96906).												B-3	37

(1) Source maint. and recov code	(2) Federal stock number	(3) Description	(4) Unit of issue	(5) Qty. inc in unit	(6) 30 day DS maint. alw.			(7) 30 day GS maint. alw.			(8) 1 Yr alw per 100 equip/ cntgcy plan ning	(9) Depot main alw per 100 equip	(10) Illustration	
					(a) 1-20	(b) 21-50	(c) 51-100	(a) 1-20	(b) 21-50	(c) 51-100			(a) Fig. No.	(b) Item No.
KF H ZZ		1 BEARING, OPERATING, SHAFT: 11662496 (19207).											B-3	38
PA H ZZ	5310-879-1677	1 NUT, SLEEVE: 7748609 (19207)											B-3	41
PA H ZZ	5305-952-8458	1 SCREW, SET: 7748533 (19207)											B-3	42
KF H ZZ		1 PLATE ASSEMBLY, SPRING: PL9055A (01843).											B-3	43
PA H ZZ	2910-252-5580	PARTS KIT, METERING AND DISTRIBUTING FUEL PUMP: governor and linkage 5704352 :(19207). Composed of:	A	EA	1				*	*	*		B-3	
KF H ZZ		1 SLEEVE ASSEMBLY: SV9028A (01843).											B-3	2
KF H ZZ		1 CAM, TORQUE: 10885781 (19207).											B-3	4
KF H ZZ		1 SCREW, CONTROL ROD: SC9037 (01843).											B-3	9
KF H ZZ		1 WASHER, SPACING: WA1983 (01843).											B-3	10
PA H ZZ	2910-751-9211	1 CLIP, RETAINING: PN1122 (01843).											B-3	13
KF H ZZ		1 SPRING, TORQUE, LINK: SP9039 (01843).											B-3	15
KF H ZZ		1 PIN ASSEMBLY : 7748545 (19207)											B-3	28
KF H ZZ		1 PIN. LOCKING: PNI258 (01843)											B-3	30
KF H ZZ		2 WASHER: WA1802-1 (01843)											B-3	31
KF H ZZ		2 WASHER: WA1802-3 (01843)											B-3	32
PA H ZZ	2910-405-4363	PARTS KIT, METERING AND DISTRIBUTING FUEL PUMP: fuel density compensator installation 5704373 (19207). Composed of:	A	EA	1				*	*	*		B-3	
KF H ZZ		1 WASHER, SPRING: WA886 (01843)											B-3	45
KF H ZZ		2 WASHER, SPACING: WA1797 (01843).											B-3	46
KF H ZZ		1 PIN, COTTER: PN2.10BL (01843)											B-3	48
PA H ZZ	2910-491-6836	PARTS KIT, METERING AND DISTRIBUTING FUEL PUMP: operating shaft 5704377 (19207). Composed of:	A	EA	1				*	*	*		B-3	
KF H ZZ		1 SHAFT ASSEMBLY OPERA,RING: SH9083A (01843).											B-3	33
PA H ZZ	5360-785-6345	1 SPRING, HELICAL, TORSION: 738472 (19207).											B-3	35
PA H ZZ	5305-263-8374	1 SCREW, SET: FFS103 TYPE2 STYLE3 (81348).											B-3	36
PA H ZZ	5310-768-0319	1 NUT, PLAIN HEXAGON: MS51968 (96906).											B-3	37

(1) Source maint. and recov code	(2) Federal stock number	(3) Description	(4) Unit of issue	(5) Qty. inc in unit	(6) 30 day DS maint. alw.			(7) 30 day GS maint. alw.			(8) 1 Yr alw per 100 equip/cntgcy planning	(9) Depot main alw per 100 equip	(10) Illustration		
					(a) 1-20	(b) 21-50	(c) 51-100	(a) 1-20	(b) 21-50	(c) 51-100			(a) Fig. No.	(b) Item No.	
PA H ZZ	2910-871-5434	1 BEARING, OPERATING SHAFT: 7748821 (19207).											B-3	38	
PA H ZZ	5310-879-1677	1 NUT, SLEEVE - 7748609 (19207).											B-3	41	
PA H ZZ	5305-952-8458	1 SCREW, SET: 7748533 (19207)											B-3	42	
PA H ZZ	2910-786-0193	1 PLATE ASSEMBLY. SPRING: 7383473 (19207).											B-3	43	
PA H ZZ	2910-786-5238	SHIM SET: fuel injection pump governor adjusting 5702638 (19207). Composed of:	EA	1				*	*	*				B-3	
KF H ZZ		1 SPACER: 7748550 (19207)											B-3	23	
KF H ZZ		1 SPACER: 7748551 (19207)											B-3	23	
KF H ZZ		1 SPACER: 7748552 (19207)											B-3	23	
KF H ZZ		1 SPACER: 7748553 (19207)											B-3	23	
KF H ZZ		1 SPACER: 7748554 (19207)											B-3	23	
KF H ZZ		1 SPACER: 7748555 (19207)											B-3	23	
KF H ZZ		1 SPACER: 7748535 (19207)											B-3	24	
KF H ZZ		1 SPACER: 7748536 (19207)											B-3	24	
KF H ZZ		1 SPACER: 7748537 (19207)											B-3	24	
KF H ZZ		1 SPACER: 7748558 (19207)											B-3	24	
KF H ZZ		1 SPACER: 7748539 (19207)											B-3	24	
KF H ZZ		1 SPACER: 748640 (19207)											B-3	24	
PA H ZZ	2910-968-6318	PARTSKIT, FUEL INJECTION PUMP: governor and linkage 5702686 (19207). Composed of:	BCD EFG	EA	1				*	*	*		B-3		
KF H ZZ		1 SLEEVE ASSEMBLY: 7748546 (19207).											B-3	2	
KF H ZZ		1 CAM, TORQUE: 10885781 (19207).											B-3	4	
KF H ZZ		1 SCREW: SC8814 (01843)	G										B-3	9	
KF H ZZ		1 SCREW, CONTROL ROD: SC9037 (01843).	BCD EF										B-3	9	
KF H ZZ		1 PIN. PIVOT: 7748545 (19207).											B-3	28	
KF H ZZ		1 PIN, COTTER: 137128 (21450)	G										B-3	55	
XA H ZZ		INJECTION PUMP HOUSING AND ASSOCIATED PARTS													
XA H ZZ		AUTOMATIC TIMING DEVICE: (used on PUMP 2910-178-1185 only) TMD9B5939A (01843).	A	EA	1								B-4	1	
XA H ZZ		AUTOMATIC TIMING DEVICE: used on PUMP 2910-759-5410 and 2910-103-2644 only)TMD9B5803A (01843).	CDE	EA	1								B-4	1	
				B-17											

(1) Source maint. and recov code	(2) Federal stock number	(3) Description	(4) Unit of issue	(5) Qty. inc in unit	(6) 30 day DS maint. alw.			(7) 30 day GS maint. alw.			(8) 1 Yr alw per 100 equip/ cntgcy plan ning	(9) Depot main alw per 100 equip	(10) Illustration	
					(a) 1-20	(b) 21-50	(c) 51-100	(a) 1-20	(b) 21-50	(c) 51-100			(a) Fig. No.	(b) Item No.
XA H ZZ		AUTOMATIC TIMING DEVICE: (used on PUMP 2910-908-6320 and 2910-017-9778 only) TMD9B1 (01843).	BF	EA	1								B-4	1
XA H ZZ		AUTOMATIC TIMING DEVICE: (used on PUMP 2910-968-6317 only) TMD9A1 (01843).	G	EA	1								B-4	1
PA H ZZ	5305-068-7837	SCREW, CAP. HEXAGON HEAD: 1/4-20UNC-2A 5/8 lg. camshaft bearing retainer plate to injection pump housing MS90728-5 (96906).		EA	4				*	*	*		B-4	2
PA H ZZ	5310-751-8776	WASHER LOCK: camshaft bearing retainer plate to injection pump housing WA901 (01843).		EA	4				*	*	*		B-4	3
PF H ZZ	2910-797-3607	PLATE: camshaft bearing retainer PL907 (01843).		EA	1				*	*	*		B-4	4
XA H ZZ		NUT. LOCK: camshaft bearing NT905 (01843).		EA	1								B-4	5
PA H ZZ	2910-717-2835	WASHER. KEY: bearing retaining WA1720 (01843).		EA	1				*	*	*		B-4	6
PA H ZZ	3110-554-6034	BEARING BALL, ANNULAR: camshaft 205KG (21335).		EA	1				*	*	*		B-4	7
PA H ZZ	2910-871-5432	CAMSHAFT: fuel injection pump 10914595 (19207).		EA	1				*	*	*		B-4	8
XA H ZZ		POINTER. TIMING: injection pump housing PO764 (01843).		EA	1								B-4	9
PA H ZZ	5330-582-1560	PACKING, PREFORMED: 3.109 id. 0.139 thk. fuel injection pump housing to timing device housing MS28775-235 (96906).		EA	1				*	*	*		B-4	10
PA H ZZ	2910-907-0673	TAPPET: fuel injection pump 10947156 (19207).	ABC	EA	1				*	*	*		B-4	11
PA H ZZ	2910-036-4152	TAPPET: fuel injection pump 10914597 (19207).	DEF G	EA	1				*	*	*		B-4	11
XA H ZZ		GUIDE: outer plunger spring seat GU9020 (01843).	ABC DEF	EA	1								B-4	12
XA H ZZ		GUIDE: outer plunger spring seat GU9013 (01843).	G	EA	1								B-4	12
PA H ZZ	5330-194-3711	PACKING. PREFORMED: 2.109 id, 0.139 thk, head assembly to injection pump housing lower packing AN6230-5 (88044).		EA	1				*	*	*		B-4	13
PA H ZZ	2910-936-5347	SLEEVE. INJECTION PUMP STUD: hydraulic head mounting SV9018 (01843).		EA	4				*	*	*		B-4	14
PA H ZZ	5310-606-6716	NUT: hydraulic head to injection pump housing NT1127 (01843).		EA	4				*	*	*		B-4	15
PA H DL	2910-828-7176	HEAD, HYDRAULIC: fuel injection pump 11602721 (19207).	CDE	EA	1				*	*	*		B-4	16
PA H DL	2910-828-7167	HEAD, HYDRAULIC: fuel injection pump 11602722 (19207).	BF	EA	1				*	*	*		B-4	16

(1) Source maint. and recov code	(2) Federal stock number	(3) Description	(4) Unit of issue	(5) Qty. inc in unit	(6) 30 day DS maint. alw.			(7) 30 day GS maint. alw.			(8) 1 Yr alw per 100 equip/ cntgcy plan ning	(9) Depot main alw per 100 equip	(10) Illustration		
					(a) 1-20	(b) 21-50	(c) 51-100	(a) 1-20	(b) 21-50	(c) 51-100			(a) Fig. No.	(b) Item No.	
PA H DL	2910-762-4623	HEAD, HYDRAULIC: fuel injection pump 11662498 (19207).	A	EA	1				*	*	*			B-4	16
PA H DL	2910-871-5435	HEAD ASSEMBLY: fuel injection pump 10914599 (19207).	G	EA	1				*	*	*			B-4	16
PA H ZZ	2910-903-7685	PACKING, PREFORMED: head assembly to injection pump housing upper packing 10935567 (19207).		EA	1				*	*	*			B-4	17
PA H ZZ	5365-804-9744	RING. RETAINING: 2.125 id, 0.078 thk, internal plunger sprint MS16625-212 (96906).		EA	1				*	*	*			B-4	18
PA H ZZ	2910-903-4803	SPRING, HELICAL, COMPRESSION: plunger outer SP9038 (01843).	ABC	EA	1				*	*	*			B-4	19
PA H ZZ	2910-619-7586	SPRING, HELICAL, COMPRESSION: plunger outer 1091487 (109207).	DEF	EA	1				*	*	*			B-4	19
XA H ZZ		HOUSING ASSEMBLY: injection pump HG9089A (01841).	ABC	EA	1									B-4	20
XA H ZZ		HOUSING ASSEMBLY: injection pump HG9067A (01843).	DEF	EA	1									B-4	20
XA H ZZ		STUD: fuel injection pump to hydraulic head SD881 (01843).	G	EA	4									B-4	21
PA D ZZ	3120-293-6197	BEARING, SLEEVE: injection pump housing BG7649 (01843).		EA	4									B-4	22
PA H ZZ	2990-977-2591	WIRE, BEARING PLATE: quill shaft cover (1), quill shaft retaining screw (2 pcs, 17.00 in. lg) W1763 (01843).		EA	2				*	*	*			B-4	23
PA H ZZ	5305-362-7079	SCREW: quill shaft pad cover to injection pump housing (2), quill shaft retaining (1) SC1140 (01843).		EA	3				*	*	*			B-4	24
PA H ZZ	5310-5699-5616	WASHER. FLAT: quill shaft pad cover to injection pump housing (2), quill shaft retaining (1) GA7616 (01843).		EA	3				*	*	*			B-4	25
PA H ZZ	2910-762-4588	WEIGHT AND SPIDER ASSEMBLY: governor 11662497 (19207).		EA	1				*	*	*			B-4	26
PA H ZZ	2910-871-5436	SHAFT ASSEMBLY: fuel injection pump quill 10914590 (19207).		EA	1				*	*	*			B-4	27
XA H ZZ		COVER: fuel injection pump quill shaft CV903C (01843).		EA	1									B-4	28
KF H ZZ		GASKET: quill shaft cover GA9032 (01843).		EA	1									B-4	29
PA H ZZ	5306-728-9969	BOLT, SEL,-LOCKING: fuel injection pump timing device housing to mounting adapter 10935554 (19207).		EA	1				*	*	*			B-4	30
PA H ZZ	5310-637-9541	WASHER, LOCK: 3/8 id, 0.683 od, 0.094 thk, timing device housing to injection pump housing MS35338-46 (96906).		EA	2				*	*	*			B-4	31

(1) Source maint. and recov code	(2) Federal stock number	(3) Description	(4) Unit of issue	(5) Qty. inc in unit	(6) 30 day DS maint. alw.			(7) 30 day GS maint. alw.			(8) 1 Yr alw per 100 equip/ cntgcy plan ning	(9) Depot main alw per 100 equip	(10) Illustration	
					(a) 1-20	(b) 21-50	(c) 51-100	(a) 1-20	(b) 21-50	(c) 51-100			(a) Fig. No.	(b) Item No.
PA H ZZ	5305-269-3213	SCREW. CAP. HEXAGON HEAD: 3/8-16UNC-2A, 1 1/4 lg, timing device housing to injection pump housing MS90725-62 (96906).	EA	2				*	*	*			B-4	32
PA H ZZ	5310-080-6004	WASHER, FLAT: 13/32 id, 13/16 od. 0.080 thk, timing device housing to injection pump housing MS27183-14 (96906).	EA	3				*	*	*			B-4	33
PA H ZZ	5315-616-5525	KEY, WOODRUFF: 5/32 wd, 5/8 lg. camshaft MS35756-9 (96906).	EA	1				*	*	*			B-4	34
PA H ZZ	5365-263-5954	GROUP 05-FUEL SUPPLY PUMP ASSEMBLY RING, RETAINING: fuel pump driven gear MS16624-31 (96906).	EA	1				*	*	*			B-5	1
XA H ZZ		GEAR: fuel pump driven GE908 (01843).	EA	1									B-5	2
PA H ZZ	5330-470-6695	SEAL. PLAIN. ENCASED: fuel pump driven gear SE1034 (01843).	EA	1				*	*	*			B-5	3
XA H ZZ		PIN: idler gear, supply pump PN9040 (01843).	EA	1									B-5	4
XA H ZZ		GEAR: idler, supply pump GE9019 (01843).	EA	1									B-5	5
XA H ZZ		COVER ASSEMBLY: fuel supply pump CV9057A (01843).	EA	1							A		B-5	6
XA H ZZ		COVER ASSEMBLY: fuel supply pump CV9011-1 (01843).	EA	1							BCD EFG		B-5	6
XA H ZZ		WASHER, LOCK: supply pump cover WA6-5BL (01843).	EA	4									B-5	7
XA H ZZ		SCREW, MACHINE: supply pump cover SC23-8BL (01843).	EA	4									B-5	8
XA H ZZ		SHAFT, DRIVE, WITH GEAR: supply pump SH9076 (01843).	EA	1									B-5	9
PA H ZZ	5315-687-5218	KEY, WOODRUFF: 1/8 wd, 3/8 lg, supply pump drive gear MS3576-3 (96906).	EA	1				*	*	*			B-5	10
XA H ZZ		HOUSING: supply pump HG9071 (01843).	EA	1									B-5	11
XA H ZZ		SPRING: fuel pump relief valve SP9040 (01S43).	EA	1									B-5	12
XA H ZZ		VALVE, CHECK: supply pump relief VA7946 (01843).	EA	1									B-5	13
KF H ZZ		GASKET: check valve GA9028 (01843).	EA	1									B-5	14
KF H ZZ		GASKET: fuel supply pump valve GA1111 (01843).	EA	1									B-5	15
XA H ZZ		SCREW. VALVE: fuel supply pump SC9038 (01843).	EA	1									B-5	16
XA H ZZ		SCREW, VALVE: fuel supply pump SC9046 1018431.	EA	1									B-5	17

(1) Source maint. and recov code	(2) Federal stock number	(3) Description	(4) Unit of issue	(5) Qty. inc in unit	(6) 30 day DS maint. alw.			(7) 30 day GS maint. alw.			(8) 1 Yr alw per 100 equip/ cntgcy plan ning	(9) Depot main alw per 100 equip	(10) Illustration		
					(a) 1-20	(b) 21-50	(c) 51-100	(a) 1-20	(b) 21-50	(c) 51-100			(a) Fig. No.	(b) Item No.	
PA H ZZ	2910-489-5994	PARTS KIT, METERING AND DISTRIBUTING FUEL PUMP: supply pump inspection 5704368 (19207) Composed of:	EA	1				*	*	*				B-5	
PA H ZZ	5365-263-5954	1 RING, RETAINING: MS16624-13 (96909)												B-5	1
PA H ZZ	5330-470-6695	1 SEAL, PLAIN, ENCASED: SE1034 (01843)												B-5	3
KF H ZZ		1 Gasket: GA9028 (01843)												B-5	14
KF H ZZ		1 GASKET: GA1111 (01843)												B-5	15
PA H ZZ	2910-751-9212	FUEL RETURN SHUTOFF ROD ASSEMBLY ROD, SHUTOFF: fuel return BCD RD903 (01843). EFG	EA	1				*	*	*				B-6	1
PA H ZZ	5330-509-3161	GASKET: fuel shutoff rod BCD GA1019 (01843). EFG	EA	1				*	*	*				B-6	2
PA H ZZ	2910-797-3617	SPRING: fuel shutoff rod return BCD SP904 (01843). EFG	EA	1				*	*	*				B-6	3
XA H ZZ		SCREW: bearing, shutoff rod BCD SC904 (01843). EFG	EA	1										B-6	4
XA H ZZ		FITTING: fuel shutoff rod BCD F19010 (01843). EFG	EA	1										B-6	5
XA H ZZ		PIN, STRAIGHT, HEADLESS: BCD PN1026 (01843). EFG	EA	1										B-6	6
PA H ZZ	5330-582-1560	AUTOMATIC TIMING DEVICE ASSEMBLY PACKING, PREFORMED: 3.109 id, 0.139 thk injection pump mounting MS28775-235 (96906).	EA	1	*	*	*	*	*	*				B-7	1
PA F ZZ	5310-582-5965	WASHER, LOCK: 1/4 id. 0.489 od, 0.062 thk, timing cover to timing device housing MS35338-44 (9606).	EA	1	*	*	*	*	*	*				B-7	2
PA F ZZ	5305-068-0501	SCREW, CAP, HEXAGON HEAD: 1/4-20UNC-2A, 5/8 lg, timing cover to timing device housing MS90725-5 (96906).	EA	4	*	*	*	*	*	*				B-7	3
PF H ZZ	2910-103-8844	COVER: fuel injection pump timing device housing timing CV9049 (01843).	EA	1				*	*	*				B-7	4
PA H ZZ	2910-871-5425	GASKET: timing device housing timing cover 7748854 (19207).	EA	1				*	*	*				B-7	5
KF H ZZ		PLATE, THRUST: spider PL9041 (01843).	EA	1										B-7	6
KF H ZZ		WEIGHT AND SPIDER ASSEMBLY: timing device WT9028A (01843).	EA	1										B-7	7

(1) Source maint. and recov code	(2) Federal stock number	(3) Description	(4) Unit of issue	(5) Qty. inc in unit	(6) 30 day DS maint. alw.			(7) 30 day GS maint. alw.			(8) 1 Yr alw per 100 equip/ cntgcy plan ning	(9) Depot main alw per 100 equip	(10) Illustration	
					(a) 1-20	(b) 21-50	(c) 51-100	(a) 1-20	(b) 21-50	(c) 51-100			(a) Fig. No.	(b) Item No.
KF H ZZ		SPACER: end play SR9014-1 (01843).	EA	1			See KIT 2910-871-5431						B-7	8
KF H ZZ		SPACER: end play SR9014-2 (01843).	EA	1			See KIT 2910-871-5431						B-7	8
KF H ZZ		SPACER: end play SR9014-3 (01843).	EA	1			See KIT 2910-871-5431						B-7	8
KF H ZZ		SPACER: end play SR9014-4 (01843).	EA	1			See KIT 2910-871-5431						B-7	8
KF H ZZ		SPACER: end play SR9014-5 (01843).	EA	1			See KIT 2910-871-5431						B-7	8
KF H ZZ		SPACER: sliding gear SR9013-8 (01843).	EA	1			See KIT 2910-871-5431						B-7	9
KF H ZZ		SPACER: sliding gear SR9013-9 (01843).	EA	1			See KIT 2910-871-5431						B-7	9
KF H ZZ		SPACER: sliding gear SR9013-10 (01843).	EA	1			See KIT 2910-871-5431						B-7	9
KF H ZZ		SPACER: sliding gear SR9013-11 (01843).	EA	1			See KIT 2910-871-5431						B-7	9
KF H ZZ		SPACER: sliding gear SR9013-12 (01843)	EA	1			See KIT 2910-871-5431						B-7	9
KF H ZZ		SPACER: sliding gear SR9013-13 (01843)	EA	1			See KIT 2910-871-5431						B-7	9
KF H ZZ		GEAR, SLIDING: ting device GE9020 (01843).	EA	1			See KIT 2910-871-5431						B-7	10
KF H ZZ		SPRING, HELICAL, COMPRESSION: timing device SP9041 (01843).	BFG	EA	3		See KIT 2910-472-1711						B-7	11
KF H ZZ		SPRING, HELICAL, COMPRESSION: timing device SP9043 (01843).	CDE	EA	3		See KIT 2910-472-1709						B-7	11
KF H ZZ		SPRING, HELICAL, COMPRESSION: timing device SP857-3 (01843).	A	EA	3		See KIT 2910-192-9433						B-7	11
KF H ZZ		NUT: camshaft NT9011 (01843).		EA	1		See KIT 2910-871-5431						B-7	12
KF H ZZ		HUB: timing device HB9037 (01843).		EA	1		See KIT 2910-871-5431						B-7	13
KF H ZZ		SCREW, SET: timing device SC313-8BL (01843).		EA	1		See KIT 2910-871-5431						B-7	14
XA H ZZ		HOUSING: timing device 11640921 (19207).		EA	1								B-7	15
KF D ZZ		BUSHING: timing device housing BG8510 (01843).		EA	1		See KIT 2910-489-2557						B-7	16
KF D ZZ		PIN: timing device housing PN9041 (01843).		EA	1		See KIT 2910-489-2557						B-7	17
PA D ZZ	2910-489-2557	PARTS KIT. METERING AND DISTRIBUTING PUMP: timing device housing 5704372 (19207) Composed of: 1 BUSHING BG8510 (01843)		EA	1								B-7	

(1) Source maint. and recov code	(2) Federal stock number	(3) Description	(4) Unit of issue	(5) Qty. inc in unit	(6) 30 day DS maint. alw.			(7) 30 day GS maint. alw.			(8) 1 Yr alw per 100 equip/ cntgcy plan ning	(9) Depot main alw per 100 equip	(10) Illustration	
					(a) 1-20	(b) 21-50	(c) 51-100	(a) 1-20	(b) 21-50	(c) 51-100			(a) Fig. No.	(a) Item No.
KF D ZZ		1 PIN PN9041 (01843)											B-7	17
PA H ZZ	2910-871-5431	REPAIR KIT, FUEL INJECTION PUMP: timing device 5702661 (19207). Composed of:	EA	1				*	*	*			B-7	
KF H ZZ		1 PLATE, THRUST PL9041 (01843)											B-7	6
KF H ZZ		1 SPIDER ASSEMBLY WT9028A (01843)											B-7	7
KF H ZZ		1 SPACER SR9014-1 (01843)											B-7	8
KF H ZZ		1 SPACER SR9014-2 (01843)											B-7	8
KF H ZZ		1 SPACER SR9014-3 (01843)											B-7	8
KF H ZZ		1 SPACER SR9014-4 (01843)											B-7	8
KF H ZZ		SPACER SR9014-5 (01843)											B-7	8
KF H ZZ		SPACER SR9013-8 (01843)											B-7	9
KF H ZZ		1 SPACER SR9013-9 (01843)											B-7	9
KF H ZZ		1 SPACER SR9013-10 (01843)											B-7	9
KF H ZZ		1 SPACER SR9013-11 (01843)											B-7	9
KF H ZZ		1 SPACER SR9013-12 (01843)											B-7	9
KF H ZZ		1 SPACER SR9013-13 (01843)											B-7	9
KF H ZZ		1 GEAR, SLIDING GE9020 (01843)											B-7	10
KF H ZZ		1 NUT, CAMSHAFT NT9011 (01843)											B-7	12
KF H ZZ		1 HUB HB9037 (01843)											B-7	13
KF H ZZ		1 SCREW, SET SC313-8BL (01843)											B-7	14
PA H ZZ	2910-472-1711	SPRING SET: timing device advance unit 5704378 (19207). (P) Composed of:	BFG EA	1				*	*	*			B-7	
KF H ZZ		3 SPRING SP9041 (01843)											B-7	11

(1) Source maint. and recov code	(2) Federal stock number	(3) Description	(4) Unit of issue	(5) Qty. inc in unit	(6) 30 day DS maint. alw.			(7) 30 day GS maint. alw.			(8) 1 Yr alw per 100 equip/ cntgcy plan ning	(9) Depot main alw per 100 equip	(10) Illustration		
					(a) 1-20	(b) 21-50	(c) 51-100	(a) 1-20	(b) 21-50	(c) 51-100			(a) Fig. No.	(a) Item No.	
PA H ZZ	2910-472-1709	SPRING SET: timing device advance unit 5704379 119207)	CDE	EA	1				*	*	*			B-7	
KF H ZZ		Composed of: 3 SPRING SP9043 (01843)												B-7	11
PA H ZZ.	2910-192-9433	SPRING SET: timing device advance unit 5704370 (19207).	A	EA	1				*	*	*			B7	
KF H ZZ		Composed of: 3 SPRING SP857-3 (01843)												B-7	11
		FUEL INJECTION TAPPET ASSEMBLY													
XA H ZZ		GUIDE ASSEMBLY: tappet GU9021A (01843)	ABC DEF	EA	1									B-8	1
XA H ZZ		GUIDE ASSEMBLY: tappet GU9011A (01843).	G	EA	1									B-8	1
XA H ZZ		PIN: tappet roller PN9039 (01843)	ABC DEF	EA	1									B-8	2
XA H ZZ		PIN: tappet roller PN9013 (01843).	G	EA	1									B-8	2
PA H ZZ	2910-036-4121	ROLLER ASSEMBLY: RL768A (01843)	ABC DEF	EA	1				*	*	*			B-8	3
PA H ZZ	2910-036-4165	ROLLER ASSEMBLY: RL903A (01843).	G	EA	1				*	*	*			B-8	3
		GOVERNOR FRICTION DRIVE SPIDER ASSEMBLY													
XA H ZZ		NUT, ADJUSTING: governor weight hub NT1261 (01843).		EA	1									B-9	1
KF H ZZ		DISK: outer spring DIC797 (01843).		EA	1									B-9	2
KF H ZZ		DISK: inner spring DC796 (01843).		EA	1									B-9	3
KF H ZZ		SPACER, RING: adjusting, spring SR794-1 (01843).		EA	1									B-9	4
KF H ZZ		SPACER, RING: adjusting, spring SR794-2 (01843).		EA	1									B-9	4
KF H ZZ		SPACER, RING: adjusting, spring SR794-3 (01843).		EA	1									B-9	4
KF H ZZ		SPACER, RING: adjusting, spring SR794-4 (01843).		EA	1									B-9	4
KF H ZZ		SPACER, RING: adjusting, spring SR794-5 (01843).		EA	1									B-9	4
KF H ZZ		SPACER, RING: adjusting, spring SR794-6 (018431).		EA	1									B-9	4

(1) Source maint. and recov code	(2) Federal stock number	(3) Description	(4) Unit of issue	(5) Qty. inc in unit	(6) 30 day DS maint. alw.			(7) 30 day GS maint. alw.			(8) 1 Yr alw per 100 equip/ cntgcy plan ning	(9) Depot main alw per 100 equip	(10) Illustration	
					(a) 1-20	(b) 21-50	(c) 51-100	(a) 1-20	(b) 21-50	(c) 51-100			(a) Fig. No.	(a) Item No.
KF H ZZ		SPACER, RING: adjusting, spider SR794-7 (01843).	EA	1			See SET 2910-407-2618						B-9	4
XA H ZZ		SPIDER, WEIGHT: governor HP9025 (01043).	EA	1									B-9	5
PA D ZZ	5310-038-0751	WASHER, FLAT: 0.036 in. thk, governor weight pin WA1448-1 (01843).	EA	1									B-9	6
PA D ZZ	5310-038-0752	WASHER, FLAT: 0.038 in. thk, governor weight pin WA1448-2 (01843).	EA	1									B-9	6
PA D ZZ	5310-038-0753	WASHER, FLAT: 0.040 in. thk, governor weight pin WA1448-3 (01843).	EA	1									B-9	6
PA D ZZ	5310-038-0754	WASHER, FLAT: 0.044 in, thk, governor weight pin WA1448.4 (01843).	EA	1									B-9	6
PA D ZZ	5310-038-0755	WASHER, FLAT: 0.048 in. thk, governor weight pin WA1448-5 (01843).	EA	1									B-9	6
XA D ZZ		HUB: governor friction drive HB9036 (01843).	EA	1									B-9	7
XA D ZZ		WEIGHT ASSEMBLY: governor WT9023A (01843).	EA	2									B-9	8
PA D ZZ	3120-051-7092	BEARING, SLEEVE: governor weight BG100380 (01843).	EA	4									B-9	9
XA D ZZ		PIN, WEIGHT: governor PN7986 (01843).	EA	2									B-9	10
PA H ZZ	2910-407-2618	PARTS KIT, METERING AND DISTRIBUTING FUEL PUMP: governor weight and spider 5704369 (19207). Composed of:	EA	1						*	*	*	B-9	
KF H ZZ		1 DISK: DC797 (01843)											B-9	2
KF H ZZ		1 DISK: DC796 (01843)											B-9	3
KF H ZZ		1 SPACER, RING: SR794-1 101843)											B-9	4
KF H ZZ		1 SPACER, RING: SR794-2 (01843)											B-9	4
KF H ZZ		1 SPACER, RING: SR794-3 (01843)											B-9	4
KF H ZZ		1 SPACER, RING: SR794-4 (01843)											B-9	4
KF H ZZ		1 SPACER, RING: SR794-5 (01843)											B-9	4
KF H ZZ		1 SPACER, RING: SR794-6 (01843)											B-9	4
KF H ZZ		1 SPACER, RING: SR794-7 (01843)											B-9	4
PA H ZZ	2910-884-4807	SPECIAL PURPOSE KITS GASKET AND PREFORMED PACKING SET: metering and distributing pump 5702663 (19207). Composed of:	EA	1						*	*	*		
PA H ZZ	2910-310-6556	1 GASKET 7383459 (19207)											B-1	14
KF H ZZ		2 SEAL, WIRE SE1006 (01843)											B-1	16
													B-2	40

(1) Source maint. and recov code	(2) Federal stock number	(3) Description	(4) Unit of issue	(5) Qty. inc in unit	(6) 30 day DS maint. alw.			(7) 30 day GS maint. alw.			(8) 1 Yr alw per 100 equip/ cntgcy plan ning	(9) Depot main alw per 100 equip	(10) Illustration	
					(a) 1-20	(b) 21-50	(c) 51-100	(a) 1-20	(b) 21-50	(c) 51-100			(a) Fig. No.	(a) Item No.
PA H ZZ	5330-419-9467	1 GASKET 11662856 (19207)											B-2	4
PA H ZZ	2910-313-2617	1 GASKET 7748850 (19207)											B-2	38
PA H ZZ	2910-292-1464	1 PACKING, PREFORMED 10914594 (19207) 17											B-2	11
PA H ZZ	5365-245-5420	1 SPACER, RING 7336789 (19207)	FG										B-2	17
PA H ZZ	5330-292-1463	1 PACKING, PREFORMED GA1012 (01843)	FG										B-2	16
PA H ZZ	5330-190-4211	1 GASKET 105453 (24617)	BCD EFG										B-2	33
KF H ZZ		1 GASKET GA9029 (08143)											B-3	1
PA H ZZ	5330-406-7316	1 GASKET 11610208 (19207)											B-3	29
PA H ZZ	5310-599-5616	7 WASHER, FLAT GA7616 (08143)											B-3	39
PA H ZZ	5330-640-9587	1 GASKET GA902 (01843)											B-4	25
PA H ZZ	5330-310-6559	1 GASKET GA76195 (01843)											B-3	25
PA H ZZ	5330-582-1560	1 PACKING, PREFORMED MS28775-235 (96906)											B-3	34
PA H ZZ	5330-194-3711	1 PACKING, PREFORMED AN6230-5 (88044)											B-4	10
PA H ZZ	2910-903-7685	1 PACKING, PREFORMED 10935567 (19207)											B-7	1
PA H ZZ		1 GASKET GA9032 (01843)											B-4	13
KF H ZZ		1 GASKET GA1019 (01843)	BCD EFG										B-4	17
PA H ZZ	5330-609-3151	1 GASKET GA1019 (01843)	BCD EFG										B-4	29
KF H ZZ		1 PIN. STRAIGHT, HEADLESS PN1026 (01843)	BCD EFG										B-6	2
PA H ZZ	2910-871-5425	1 GASKET 7748854 (19207)											B-6	6
													B-7	5

Section III. SPECIAL TOOLS LIST

(1) Source maint. and recov code	(2) Federal stock number	(3) Description	(4) Unit of issue	(5) Qty. inc in unit	(6) 30 day DS maint. alw.			(7) 30 day GS maint. alw.			(8) 1 Yr alw per 100 equip/ cntgcy plan ning	(9) Depot main alw per 100 equip	(10) Illustration	
					(a) 1-20	(b) 21-50	(c) 51-100	(a) 1-20	(b) 21-50	(c) 51-100			(a) Fig. No.	(a) Item No.
		2604-SPECIAL TOOLS												
PE H ZZ	4910-793-5040	GAGE: governor spring 10882854 (19207).	EA	1				1	1	1	6		B-10	1
PE H ZZ	5120-870-6926	WRENCH, SPANNER: bearing retaining locknut 10899169 (19207).	EA	1				1	1	1	6		B-10	2
PE H ZZ	5120-870-6925	COMPRESSOR, SPRING: tappet spring 10899170 (19297).	EA	1				1	1	1	6		B-10	3
PE H ZZ	4910-870-2131	FIXTURE: camshaft holding 10899172 (19207).	EA	1				1	1	1	6		B-10	4
PE H ZZ	5120-793-6048	PULLER, MECHANICAL: advance hub and governor spider (use with REMOVER AND REPLACER 5120-793-5055) 10882818 (19207).	EA	1				1	1	1	6		B-10	5
PE H ZZ	5120-793-5046	WRENCH. SPANNER: spring disk adjusting nut (use on PUMP 2910-860-2333) 10882889 (19207).	EA	1				1	1	1	6		B-10	6
PE H ZZ	5120-793-5055	REMOVER AND REPLACER: tappet spring plunger lock, camshaft bearing, and spider weight (use -with PULLER 5120-793-5048) 10882856 (19207).	EA	1				1	1	1	6		B-10	7
PE H ZZ	4910-870-2128	FIXTURE, METERING PUMP HOLDING: 10899198 (19207).	EA	1				1	1	1	6		B-10	8
PE H ZZ	5120-134-7462	TEMPLATE, ARM ADJUSTING: fuel injection pump throttle arm 11642005 (19207).	EA	1				1	1	1	6		B-10	9

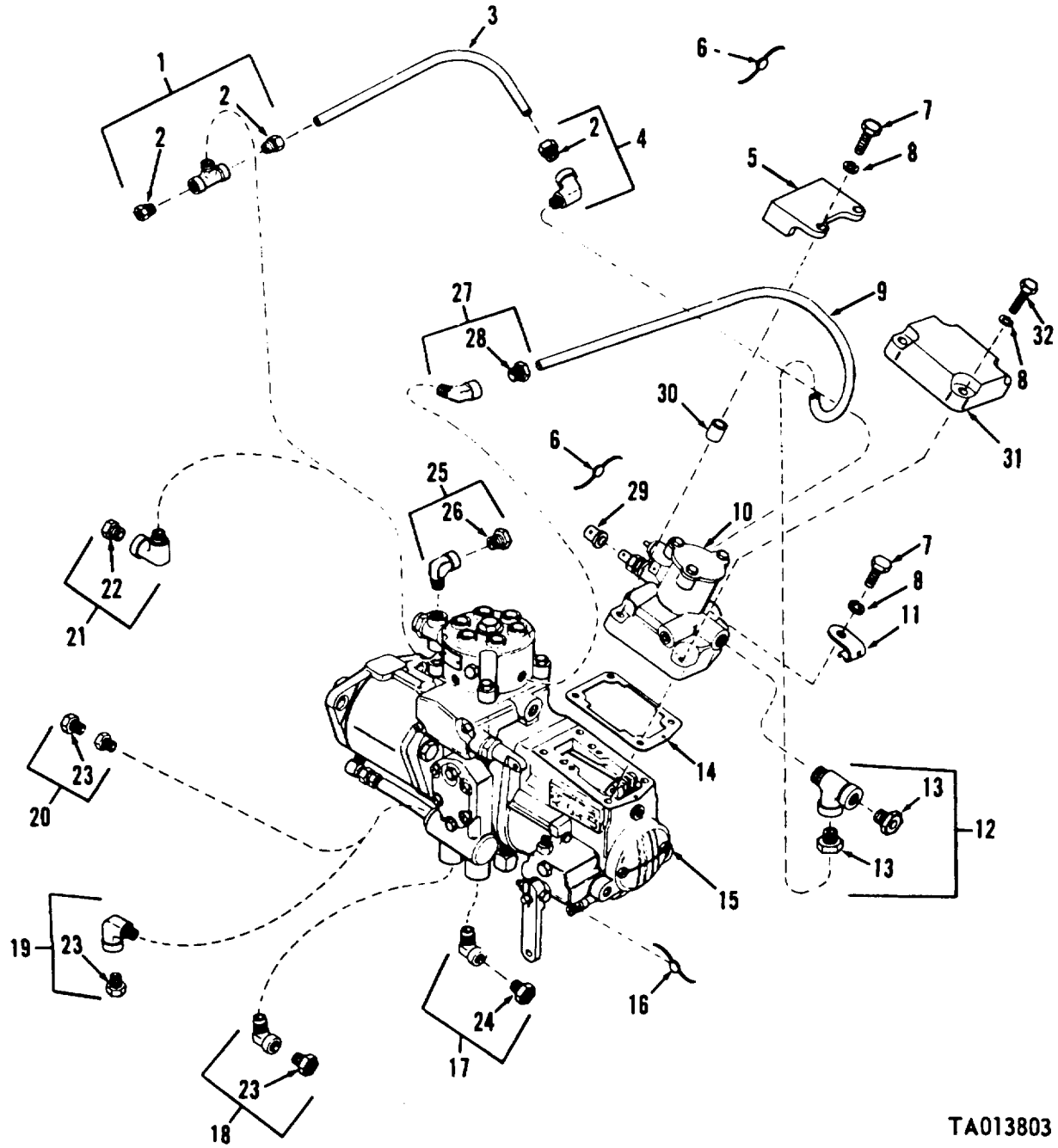

TA013803

Figure B-1. Metering and distributing fuel injection pump assembly

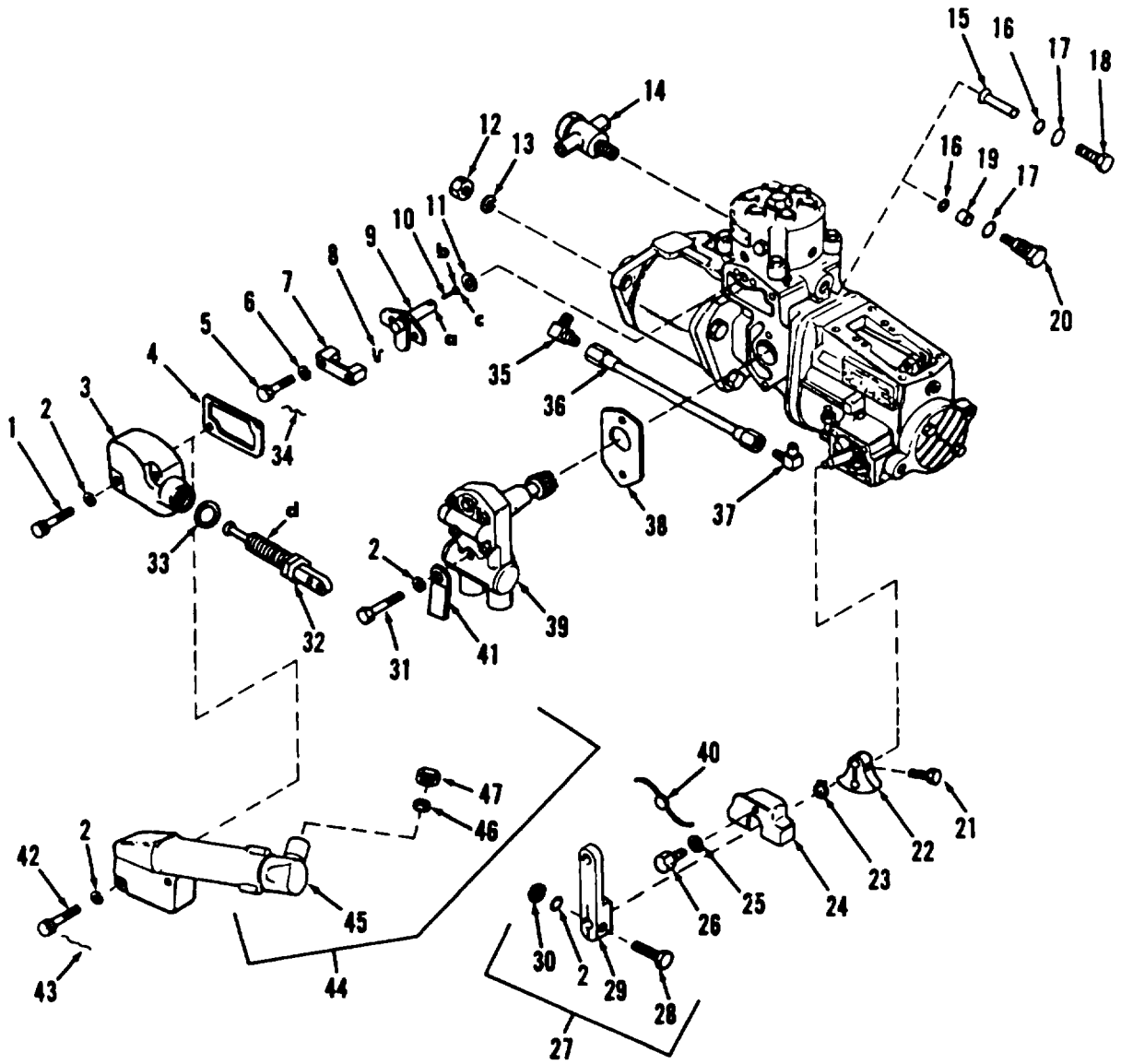

TA013804

Figure B-2. Fuel supply pump and operating lever

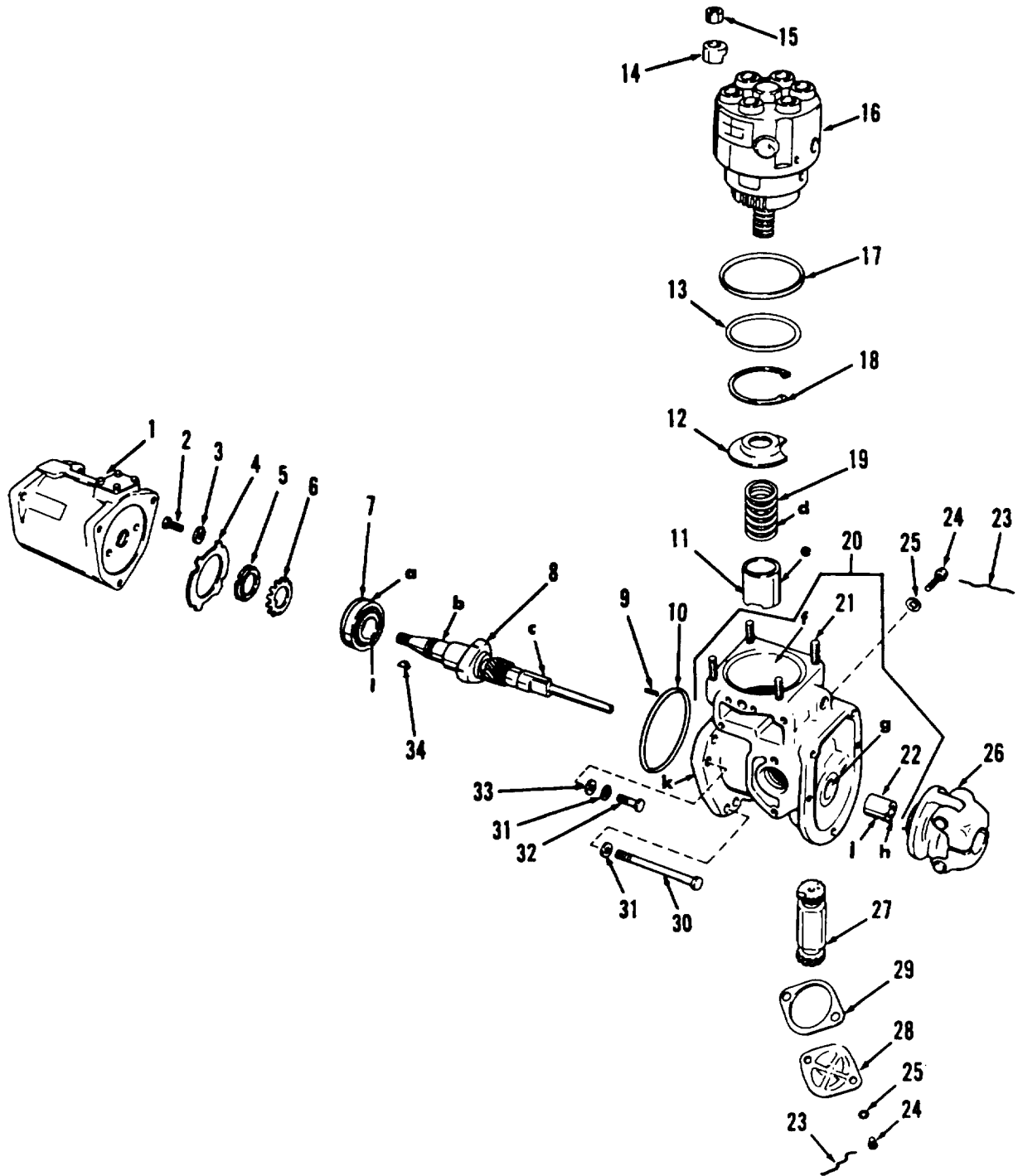

TA013806

Figure B-4. Injection pump housing and associated parts.

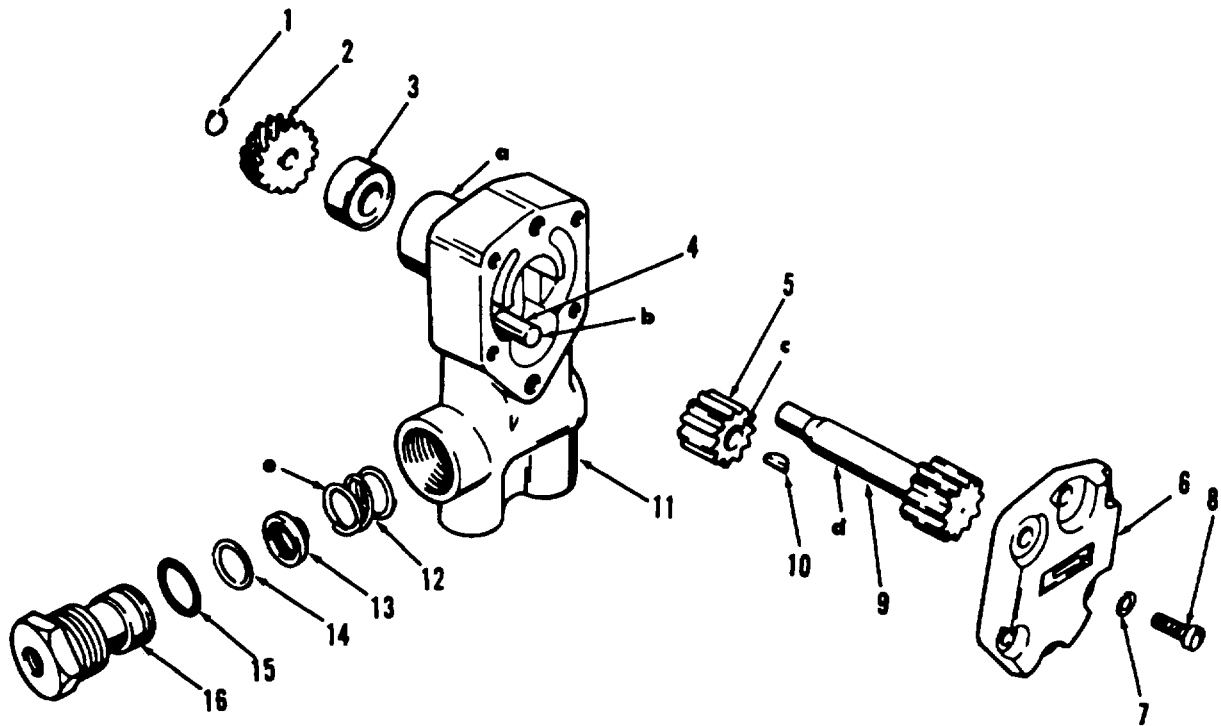

TA013807

Figure B-5. Fuel supply pump assembly

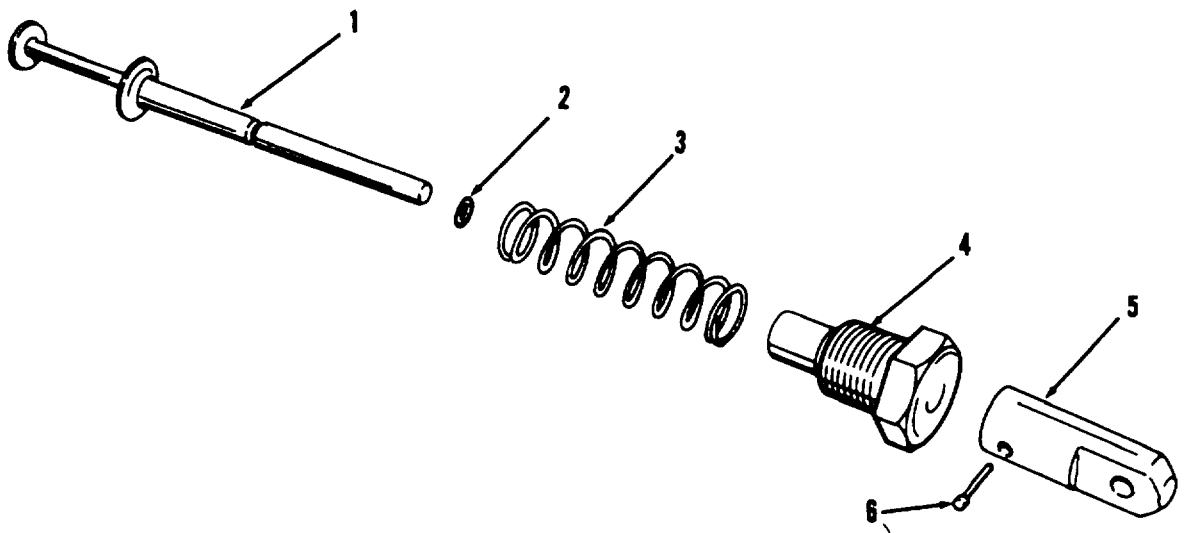

TA013808

Figure B-6. Fuel return shutoff rod assembly.

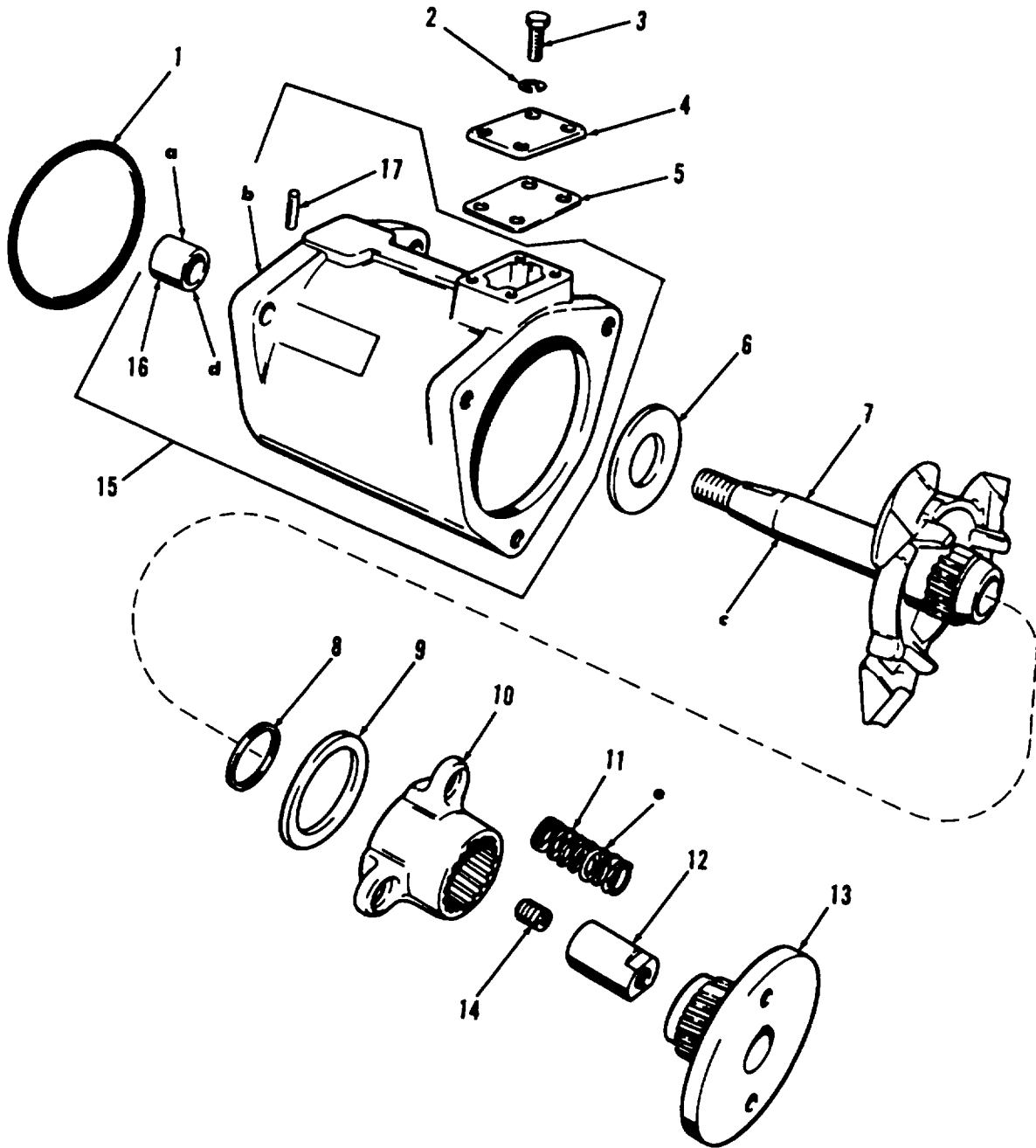

TA013809

Figure B-7. Automatic timing device assembly.

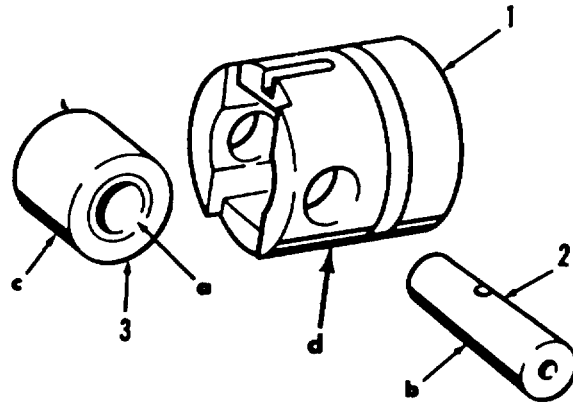

TA013810

Figure B-8. Injection pump tappet assembly

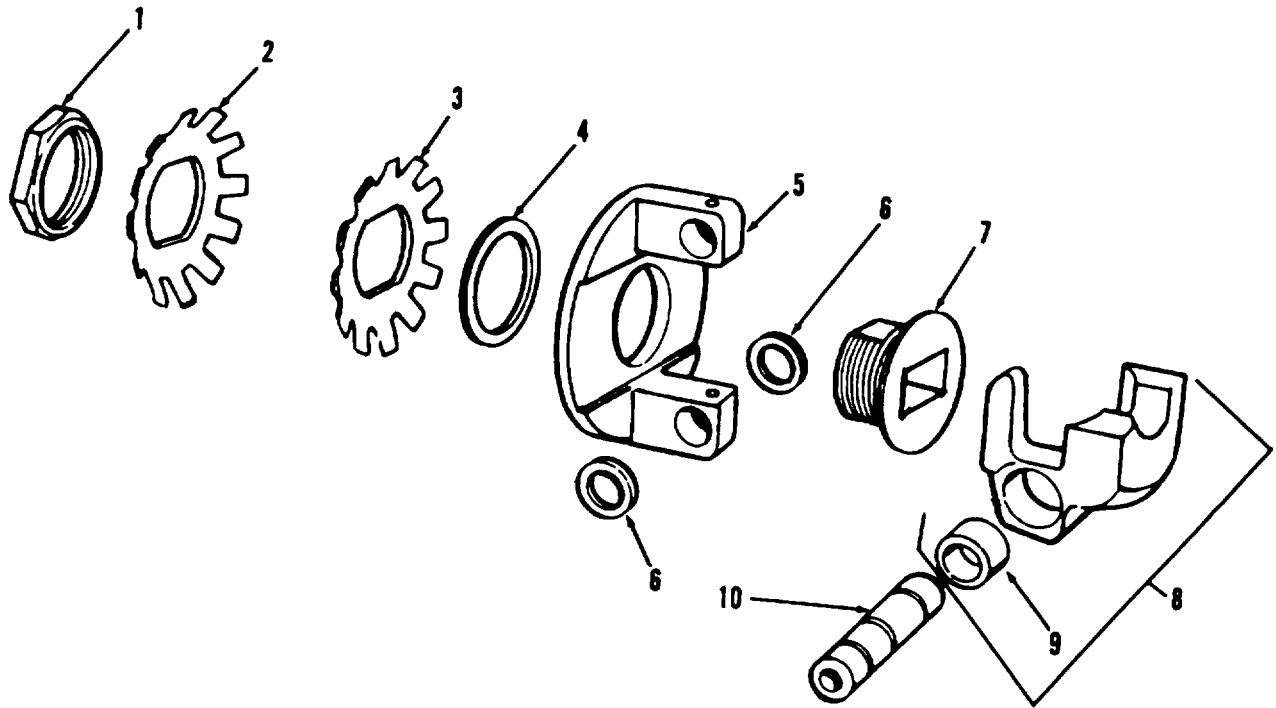

TA013811

Figure B-9. Governor friction drive spider assembly

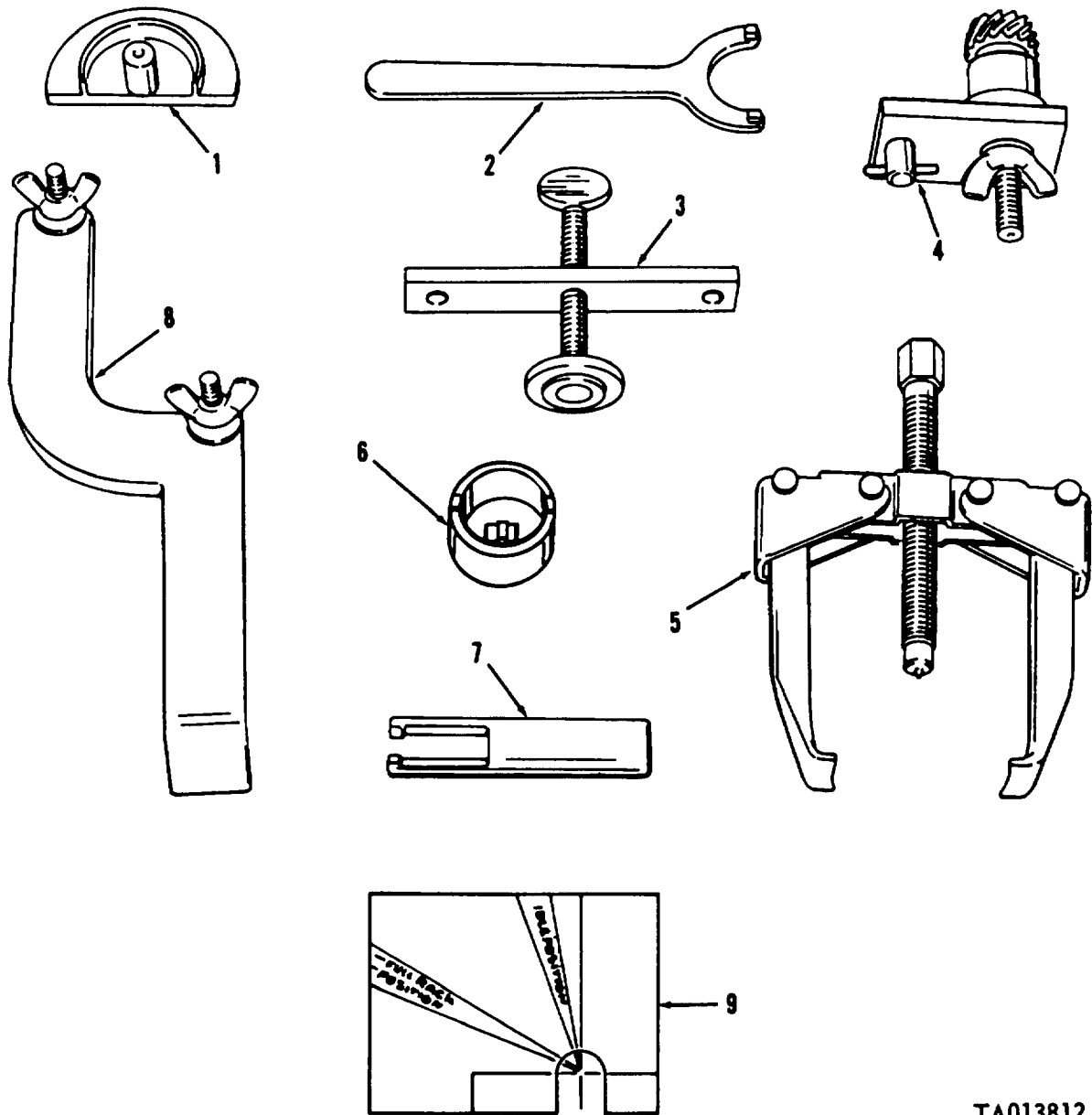

TA013812

Figure B-10. Special tools.

Section IV. FEDERAL STOCK NUMBER AND PART NUMBER INDEX

Federal stock number cross-reference to figure number and item number

FEDERAL STOCK NUMBER	FIGURE NO	ITEM NO	STOCK NUMBER	FIGURE NO	ITEM NO
2910-033-5249	B-3	53	2910-908-6324	B-2	14
2910-036-4121	B-8	3	2910-936-5347	B-4	14
2910-036-4152	B-4	11	2910-936-5349	B-3	12
2910-036-4155	B-8	3	2910-936-7780	B-2	9
2910-036-4161	B-2	7	2910-937-7833	B-2	14
2910-103-8844	B-7	4	2910-968-6317	B-1	
2910-103-8845	B-2	3	2910-968-6318	B-3	
2910-116-8241	B-1		2910-968-6320	B-2	27
2910-178-1185	B-1		2910-999-5407	B-3	3
2910-192-9433	B-7		2990-830-3882	B-3	22
2910-194-4644	B-3		2990-850-3260	B-3	21
2910-235-4791	B-3	56	2990-977-2591	B-2	34
2910-246-3997	B-1			B-2	43
2910-252-5580	B-3			B-3	19
2910-292-1464	B-2	11		B-4	23
2910-301-8733	B-2	19	3110-554-6034	B-4	7
2910-310-6556	B-1	14	3120-051-7092	B-9	9
2910-313-2617	B-2	38	3120-293-6197	B-4	22
2910-405-4363	B-3		4320-908-6321	B-2	39
2910-407-2618	B-9		4320-908-6322	B-2	39
2910-411-8312	B-3	3	4320-999-2276	B-2	39
2910-421-3941	B-2	44	4710-726-5459	B-1	
2910-433-2237	B-2		4720-135-4424	B-1	
2910-472-1709	B-7		4720-223-7016	B-1	9
2910-472-1711	B-7		4720-879-1676	B-2	36
2910-489-2557	B-7		4730-044-4040	B-1	19
2910-489-5994	B-5		4730-057-5555	B-3	49
2910-491-6836	B-3		4730-203-2866	B-1	17
2910-492-8142	B-3	44		B-1	25
2910-492-8143	B-2	27	4730-278-3676	B-1	17
2910-619-7586	B-4	19		B-1	25
2910-717-2835	B-4	6	4730-278-8368	B-1	2
2910-751-9211	B-2	8		B-1	22
	B-3	13		B-1	23
2910-751-9212	B-6	1	4730-288-9391	B-1	13
2910-759-5410	B-1			B-1	24
2910-762-4588	B-4	26		B-1	26
2910-762-4590	B-3	3		B-1	28
2910-762-4623	B-4	16	4730-289-5420	B-1	1
2910-785-6353	B-2	22	4730-585-2779	B-2	20
2910-786-0193	B-3	43	4730-764-2328	B-1	12
2910-786-5238	B-3		4730-843-4740	B-1	20
2910-797-3607	B-4	4	4730-851-0173	B-1	18
2910-797-3617	B-6	3		B-1	25
2910-828-7167	B-4	16		B-1	27
2910-828-7176	B-4	16	4730-879-1663	B-2	35
2910-836-7316	B-3	21	4730-882-8621	B-1	4
2910-871-5425	B-7	5		B-1	21
2910-871-5429	B-2	27	4730-882-8624	B-1	18
2910-871-5431	B-7		4730-882-8624	B-1	19
2910-871-5432	B-4	8	4730-900-6319	B-1	12
2910-871-5434	B-3	38	4730-901-8129	B-1	27
2910-871-5435	B-4	16	4730-903-6645	B-2	37
2910-871-5436	B-4	27	4820-125-3797	B-1	10
2910-871-5437	B-2	9	4910-793-5040	B-10	1
2910-871-5439	B-2	32	4910-870-2128	B-10	8
2910-871-5440	B-2	14	4910-870-2131	B-10	4
2910-884-4807			5120-134-7462	B-10	9
2910-903-4803	B-4	19	5120-793-5046	B-10	6
2910-903-7685	B-4	17	5120-793-5048	B-10	5
2910-907-0665	B-1	10	5120-793-5055	B-10	7
2910-907-0673	B-4	11	5120-870-6925	B-10	3
2910-907-0674	B-2	9	5120-870-6926	B-10	2
2910-908-6320	B-1		5305-068-0501	B-7	3

Federal stock number cross-reference to figure number and item number

FEDERAL STOCK NUMBER	FIGURE NO	ITEM NO	Stock Number	FIGURE NO	ITEM NO
5305-068-7837	B-4	2		B-3	50
5305-071-2238	B-1	7		B-7	2
5306-116-1613	B-3	8	5310-599-5616	B-3	39
5305-247-7065	B-1	7		B-3	39
5305-263-8374	B-3	36		B-4	25
5305-269-3213	B-4	32	5310-606-6716	B-4	15
5305-362-7079	B-3	18	5310-637-9541	B-4	31
	B-3	51	5310-655-9484	B-2	30
	B-4	24	5310-682-5930	B-1	8
5305-405-2002	B-2	42	5310-751-8776	B-4	3
5305-543-4302	B-3	40	5310-768-0319	B-3	37
5305-543-4925	B-2	6	5310-879-1677	B-3	41
5305-952-8458	B-3	42	5315-217-3457	B-2	10
5305-952-8458	B-3	42	5316-616-6525	B-4	34
5305-964-0560	B-2	31	5315-687-5218	B-5	10
5306-728-9959	B-4	30	5330-190-4211	B-2	33
5306-810-0053	B-2	26	5330-194-3711	B-4	13
5306-816-5803	B-1	32	5330-292-1463	B-2	16
5306-952-8456	B-2	21	5330-310-6659	B-3	34
5310-038-0751	B-9	6	5330-406-7316	B-3	29
5310-038-0752	B-9	6	5330-419-9467	B-2	4
5310-038-0753	B-9	6	5330-470-6695	B-5	3
5310-038-0754	B-9	6	5330-509-3151	B-6	2
5310-038-0755	B-9	6	5330-582-1560	B-4	10
5310-045-3296	B-2	6		B-7	1
5310-045-5207	B-2	46	5330-640-9587	B-3	25
5310-080-6004	B-4	33	5340-698-3442	B-1	6
5310-167-0680	B-2	13	5340-911-5724	B-1	11
5310-193-7574	B-2	25	5340-930-5140	B-3	22
5310-361-9835	B-2	30	5360-081-5977	B-3	21
	B-3	7	5360-785-6345	B-3	35
	B-3	57	5365-245-5420	B-2	17
5310-491-0319	B-2	12	5365-263-5869	B-2	23
5310-515-3030	B-3	52	5365-263-5954	B-5	1
5310-582-5965	B-2	2	5365-431-6652	B-1	30
	B-3	6	5365-804-9744	B-4	18
			5935-987-1079	B-2	45

Reference number cross-reference to manufacture's code, figure number, and item number

REFERENCE NUMBER	MFG CODE	FIG NO	ITEM NO	REFERENCE NUMBER	MFG CODE	FIG NO.	ITEM NO.
AN6230-5	88044	B-4	13	GA76195	01843	B-3	34
BA902	01843	B-3	16	GA902	01843	B-3	25
BA904	01843	B-3	16	GA9028	01843	B-4	14
BA906	01843	B-3	16	GA9029	01843	B-3	1
BG100380	01843	B-9	9	GA9032	01843	B-4	29
BG7649	01843	B-4	22	GP9019	01843	B-5	5
BG8510	01843	B-7	16	GE9020	01843	B-7	10
CP901	01843	B-3	26	GE908	01843	B-5	2
CV79241	01843	B-2	24	GU9011A	01843	B-8	1
CV9011-1	01843	B-6	6	GU9013	01843	B-4	12
CV9018	01843	B-2	3	GU9020	01843	B-4	12
CV903C	01843	B-4	28	GU9021A	01843	B-8	1
CV9032C	01843	B-1	31	HB9036	01843	B-9	7
CV9049	01843	B-7	4	HB9037	01843	B-7	13
CV9050	01843	B-2	24	HG9067A	01843	B-4	20
CV9057A	01843	B-6	6	HG9071	01843	B-5	11
DC796	01843	B-9	3	HG9079	01843	B-3	20
DC797	01843	B-9	2	HG9089A	01843	B-4	20
FE901	01843	B-2	19	HG9098	01843	B-3	20
FFS103	81348	B-3	36	HP9025	01843	B-9	5
FFW100	01843	B-2	25	LE90102	01843	B-2	29
F11286	01843	B-2	35	LE90117	01843	B-2	29
F19010	01843	B-4	5	LE90119A	01843	B-3	5
GA1012	01843	B-2	16	LE9083	01843	B-2	29
GA1019	08143	B-6	2	LE984A	01843	B-3	5
GA1111	01843	B-6	15	LK9016A	01843	B-3	44
GA7616	01843	B-4	39	MS15796-908	96906	B-2	46

Reference number cross-reference to manufacture's code, figure number, and item number

REFERENCE NUMBER	MFG CODE	FIG NO	ITEM NO	REFERENCE NUMBER	MFG CODE	FIG NO.	ITEM NO.
MS16624-13	96906	B-5	1	SC8814	01843	B-3	9
MS16624-31	96906	B-5	1	SC903	01843	B-2	20
MS16624-37	96906	B-2	23	SC9037	01843	B-3	9
MS16625-212	96906	B-4	18	SC9038	01843	B-5	16
MS20822-6B	96906	B-1	17	SC904	01843	B-6	4
		B-1	26	SC9043	01843	B-2	28
MS27183-14	96906	B-4	33	SC9046	01843	B-5	16
MS28775-235	96906	B-4	10	SC9062	01843	B-2	18
		B-7	1	SD881	01843	B-4	21
MS35265-66	96906	B-2	5	SE1006	01843	B-1	16
MS35265-79	96906	B-4	40			B-2	40
MS36338-43	96906	B-2	0	SE1034	08143	B-6	3
MS35338-44	96906	B-2	2	SGB25C19	01843	B-2	39
		B-3	6	SH9076	01843	B-6	9
		B-3	50	SH9083A	01843	B-3	33
		B-7	2	SH9D95A	01843	B-3	33
MS35338-46	96906	B-4	31	SP7961-13	01843	B-3	22
MS35338-49	96906	B-2	13	SP857-3	01843	B-7	11
MS36340-44	96906	B-1	8	SP9038	01843	B-4	19
MS35756-3	96906	B-6	10	SP9039	01843	B-3	15
MS357669	96906	B-4	34	SP904	01843	B-6	3
MS49005-6	96906	B-3	49	SP9040	01843	B4	12
MS51096-311	96906	B-2	31	SP9041	01843	B-7	11
MS51938-2	96906	B-1	6	SP9043	01843	B-7	11
MS51968-2	96906	B-3	37	SP9049	01843	B-3	17
MS90725-13	96906	B-1	7	SR794-1	01843	B-9	4
MS90725-6	96906	B-7	3	SR794-2	01843	B-9	4
MS90725-62	96906	B-4	32	SR794-3	01643	B-9	4
MS90728-5	96906	B-4	2	SR794-4	01843	B-9	4
NT1127	01843	B-4	15	SR794-5	01843	B-9	4
NT1239	01843	B-4	11	SR794-6	01843	B-9	4
NT1261	01843	B-9	1	SR794-7	01843	B-9	4
NT8-BL	01843	B-2	30	SR9013-8	01843	B-7	9
		B-3	7	SR9013-9	01843	B-7	9
		B-3	67	SR9013-10	01643	B-7	9
NT9011	01843	B-7	12	SR9013-11	01843	B-7	9
NT905	08143	B-4	5	SR9013-12	01843	B-7	9
PL9041	01843	B-7	6	SR9013-13	01843	B-7	9
PL9055A	01843	B-3	43	SR9014-1	01843	B-7	8
PL907	01843	B-4	4	SR9014-2	01843	B-7	8
PN1026	01843	B-6	6	SR9014-3	01843	B-7	8
PN1122	01843	B-2	8	SR9014-4	01843	B-7	8
		B-3	13	SR9014-5	01843	B-7	8
PN1258	01843	B-3	30	SV9018	01843	B-4	14
PN2-10BL	01843	B-3	48	SV9028A	01843	B-3	2
PN7986	01843	B-9	10	TMD9A1	01843	B-4	1
PN9013	01843	B-8	2	TMD9B1	01843	B-4	1
PN9039	01843	B-8	2	TMD9B5803A	01843	B-4	1
PN9040	01843	B-5	4	TMD9B5939A	01843	B-4	1
PN9041	01843	B-7	17	VA7946	01843	B-5	13
PN9052	01843	B-2	15	VA9053A	01834	B-2	14
PN906	01843	B-2	10	WA1448-1	01843	B-9	6
P0764	01843	B-4	9	WA1448-2	01843	B-9	6
RD7049A	01843	B-3	12	WA1448-3	01843	B-9	6
RD903	01843	B-6	1	WA1448.4	01843	B-9	6
RD9045A	01843	B-4	12	WA1448.5	01843	B-9	6
RL768A	01843	B-8	3	WA1720	01843	B-4	6
RL903A	01843	B-8	3	WA1797	01843	B-3	46
RN9011	01843	B-2	7	WA1802-1	01843	B-3	31
SC1140	01843	B-3	18	WA1802-3	01843	B-3	32
		B-3	51	WA1807	01843	B-3	14
		B-4	24	WA1983	01843	B-3	10
SC1769	01843	B-2	28	WA6-5BL	01843	B-5	7
SC1960	01843	B-3	27	WA886	01843	B-3	45
SC23-8BL	01843	B-5	8	WA901	01843	B-4	3
SC27-20BL	01843	B-2	1	W1763	01843	B-2	34
SC313-8BL	01843	B-7	14	WT49023A	01843	B-9	8
SC7961	01843	B-2	28	WT9028A	01843	B-7	7

Reference number cross-reference to manufacture's code, figure number, and item number

REFERENCE NUMBER	MFG CODE	FIG NO	ITEM NO	REFERENCE NUMBER	MFG CODE	FIG NO.	ITEM NO.
W1763	01843	B-4	23	11640921	19207	B-7	15
105453	24617	B-2	33	11641826-1	19207	B-1	7
10861278	19207	B-1		11641870	19207	B-1	10
10882818	19207	B-10	5	11641873	19207	B-3	47
10882854	19207	B-10	1	11641906	19207	B-1	15
10882856	19207	B-10	7	11641907	19207	B-1	
10882889	19207	B-10	6	11642005	19207	B-10	9
10885781	19207	B-3	4	11662495	19207	B-2	27
10896235	19207	B-1	11	11662496	19207	B-3	38
10898716	19207	B-12	12	11662497	19207	B-4	26
10899169	19207	B-10	2	11662498	19207	B-4	16
10899170	19207	B-10	3	11662499	19207	B-2	44
10899172	19207	B-10	4	11662500	19207	B-2	9
10899198	19207	B-10	8	11662502	19207	B-3	3
10910348	19307	B-2	27	11662504	19207	B-2	42
10914555	19207	B-1	1	11662856	19207	B-2	4
10914587	19207	B-4	19	11668460	19207	B-3	21
10914588	19207	B-2	9	137128	21450	B-3	55
10914590	19207	B.4	27	205KG	21335	B-4	7
10914594	19207	B-2	11	43N71918-10	10001	B-2	30
10914595	19207	B-4	8	444040	21450	B-1	19
10914597	19207	B-4	11	5153030	19204	B-3	52
10914598	19207	B-2	32	5702638	19207	B-3	
10914599	19207	B-4	16	5702661	19207	B-7	
10923499	19207	B-3	21	5702663	19207		
10935237-3	19207	B-1	9	5702685	19207	B-3	
10935261	19207	B-1	15	5704352	19207	B-3	
10935261-2	19207	B-1	15	5704368	19207	B-5	
10935264	19207	B-1		5704369	19207	B-9	
10935264-2	19207	B-1		5704370	19207	B-7	
10935295	19207	B-1		5704371	19207	B-3	
10935303	19207	B-2	27	5704372	19207	B-7	
10935304	19207	B-2	21	5704373	19207	B-3	
10935554	19207	B-4	30	5704374	19207	B-2	
10935557	19207	B-2	37	5704377	19207	B-3	
10935567	19207	B-4	17	5704378	19207	B-7	
10938294	19207	B-2	41	5704379	19207	B-7	
10947152	19207	B-2	9	589586	21450	B-3	8
10947153	19207	B-2	39	7336789	19207	B-2	17
10947156	19207	B-4	11	7383419	19207	B-2	22
10947167	19207	B-2	14	7383456	19207	B-1	32
10947542	19207	B-3	53	7383459	19207	B-1	14
10947543	19207	B-3	56	7383466	19207	B-2	26
10947544	19207	B-3	3	7383472	19207	B-3	35
10947545	19207	B-3	3	7383473	19207	B-3	43
10947558	19207	B-2	39	7383478	19207	B-3	36
10951113	19207	B-3	21	7748533	19207	B-3	42
10951115	19207	B-1		7748636	19207	B-3	24
10951116	19207	B-1	15	7748535	19207	B-3	24
10951181	19207	B-1	27	7748536	19207	B-3	24
10951182	19207	B-1	17	7748537	19207	B-3	24
		B-1	25	7748538	19207	B-3	24
10951183	19207	B-1	12	7748539	19207	B-3	24
10951187	19207	B-1	18	7748540	19207	B-3	24
		B-1	19	7748545	19207	B-3	28
10951200	19207	B-1	10	7748546	19207	B-3	2
10951317	19207	B-1	20	7748547	19207	B-3	54
11581685	19207	B-3	22	7748550	19207	B-3	23
11601150	19207	B-2	47	7748551	19207	B-3	23
11602721	19207	B-4	16	7748552	19207	B-3	23
11602722	19207	B-4	16	7748653	19207	B-3	23
11609976	19207	B-1		7748554	19207	B-3	23
11609976-5	19207	B-1	3	7748555	19207	B-3	23
11610208	19207	B-3	29	7748609	19207	B-3	41
11610343	19207	B-1	29	7748609	19207	B-3	41
11610344	19207	B-1	5	7748821	19207	B-3	38
11610356	19207	B-1		7748843	19207	B-2	14
11610388	19207	B-1	30	7748847	19207	B-2	36

Reference number cross-reference to manufacture's code, figure number, and item number

REFERENCE NUMBER	MFG CODE	FIG NO	ITEM NO	REFERENCE NUMBER	MFG CODE	FIG NO.	ITEM NO.
7748850	19207	B-2	38			B-1	26
7748854	19207	B.7	6			B-1	28
7982399	19207	B-2	45	89LB14X1-8	30327	B-1	4
81LB1-4	30327	B-1	2			B-1	21
		B-1	22	9402799	19207	B-1	18
		B-1	23			B-1	25
81LB3-8	30327	B-1	13			B-1	27
		B-1	24	9403098	19207	B-1	12

INDEX

	Paragraph or Table	Page		Paragraph or Table	Page
Adjustments (see Tests and Adjustments)			Fuel Supply Pump Assembly		
Advancement, Timing	1-26	1-29	Description	1-14, 1-15	1-22, 1-23
Appendix I. References		A-1	Installation	3-48	3-90
Appendix II. Repair Parts List and Special Tools			Pressure Table	T3-10	3-106
Introduction			Removal	3-4	3-0
Repair Parts List		B-0	Repair	3-20	3-30
Table Recoverable and Direct			Repair Standards	3-62	3-112
Exchange Items	TB-1	B-3	Governor		
Table, Repair Kits and Sets	TB-2	B-4	Description	1-13	1-20
Calibration of Pump			Installation	3-43	3-82
Calibration	3-58	3-104	Removal	3-10	3-5
Code A Pump	T3-7	3-100	Repair	3-25	3-38
Code B, Frumps	T3-6	3-99	Spacer Dimensions, Table	T3-11	3-110
Code C, D, Grumps	T3-5	3-99	Speed Governing	1-25	1-28
Code E Pump	T3-4	3-98	Governor Weight and Spider Assembly		
Precalibration	3-56	3-101	Installation	3-42	3-81
Preparation for Calibration	3-57	3-10	Removal	3-11	3-6
Cam Angle, Smoke Limit Torque	T3-8	3-102	Repair	3-26	3-58
Camshaft			Hydraulic Head Assembly		
Description	1-10	1-20	Description	1-8	1-16
Installation	3-37	3-69	Installation	3-40	3-74
Removal	3-16	3-10	Removal	3-13	3-7
Repair	3-31	3-64	Repair	3-28	3-61
Cleaning and Inspection			Selection	T 3-2	3-75
After Disassembly	3-18	3-29	Test, Leak	3-55	3-98
Before Disassembly	3-2	3-0	Test, Port Closing	3-53	3-97
Codes, Pump	1-1	1-1	Identification of Injection Pump Parts		
Common Tools	2-3	2-1	Exploded Views	3-36	3-68
Compensator (see Fuel Density Compensator)			General	3-17	3-11
Control Unit Assembly, Fuel			Table	T3-1	3-12
Installation	3-44	3-86	Improvised Tools	2-5	2-1
Removal	3-8	3-3	Injection Pump (see Fuel Injection Pump)		
Repair	3-23	3-35	Injection Pump Housing		
Conversions, pump...	3-49	3-91	Description	1-6	1-14
Cover, Timing Window (see Shutoff Rod and			Repair	3-32	3-67
Shutoff Solenoid Assemblies).			Kits, Repair,	3-35	3-68
Data, Fuel Injection Pump	1-28	1-31	Table, Kits and Sets	TB-1	B-3
Delivery Valve Test	3-54	3-98	Lines and Fittings, Plastic-Repair	3-33e	3-67
Description (see specific item)			Lubrication, Oil	1-21	1-25
Difference between Models	T1-1	1-32	Metering and Control, Fuel	1-24	1-28
Direct and General Support	1-2	1-13	Miscellaneous Components-Repair	3-33	3-67
Forms, Records and Reports	1-3	1-13	Model Differences	T1-1	1-32
Fuel Control Unit Assembly			Oil Filter-Repair	3-33b	3-67
Installation	3-44	3-86	Oil Hose-Repair	3-33c	3-67
Removal	3-8	3-3	Oil Lubrication	1-21	1-25
Repair	3-23	3-35	Operation (see specific item)		
Fuel Density Compensator			Overflow Valve Assembly		
Description	1-17,1-18,		Description	1-9	1-20
and 1-19		1-24	Inspection	3-19	3-30
Installation	3-46	3-87	Installation	3-45	3-87
Operation(Typical).	1-26	1-29	Removal	3-7	3-2
Removal	3-9	3-3	Pumping and Distribution, Fuel	1-23	1-27
Repair	3-24	3-36	Quill Shaft Assembly		
Fuel Flow	1-22	1-27	Description	1-12	1-20
Fuel Injection Pump			Installation	3-38	3-71
Assembly, General	3-34	3-68	Removal	3-15	3-9
Cleaning Before Disassembly	3-2	3-0	Repair	3-30	3-64
Conversions	3-49	3-91	Recoverable and Direct Exchange Items		
Data	1-28	3-61	Repair Kits	T B-1	B-3
Description, General	1-5	1-13	Table, Kits and Sets	3-35	3-68
Localization of Components	1-4	1-13	Repair Parts List, Appendix II	TB-1	B-3
Parts Identification	T3-1,3-36	3-12,3-68	Repair Standards		
Removal and Installation	3-1	30	Advance Unit Assembly	3-63	3-113
Repair Kits	3-35	3-68	Fuel Supply Pump	3-62	3-112
Repair Standards	3-60	3-110			
Fuel Shutoff Assembly (see Shutoff Rod or					
Shutoff Solenoid).					

	Paragraph or Table	Page		Paragraph or Table	Page
Injection Pump	3-60	3-110	Precalibration Adjustments	3-56	3-104
Tappet Assembly	3-61	3-112	Preparation for Calibration	3-57	3-104
Shutoff Rod Assembly, Fuel			Preparation for Hydraulic Head Tests	3-52	3-94
Description	1-7	1-16	Tables:		
Installation	3-47	3-89	Calibration	T 3-4	3-98
Removal	3-5	3-1		T 3-5	3-99
Repair	3-21	3-33		T 3-6	3-99
Shutoff Solenoid Assembly, Fuel			Fuel Supply Pump Pressure	T3-10	3-106
Description	1-7	1-16	Governor Spacer Dimensions	T3-11	3-110
Installation	3-47	3-89	Smoke Limit Torque Cam Angle	T3-8	3-102
Removal	3-6	3-1	Specific Gravity	T3-9	3-105
Repair	3-22	3-34	Test Stand Accessory Kit	T3-3	3-94
Smoke Limit Torque Cam Angle	T3-8	3-102	Timing Device Assembly		
Spacer Dimensions, Governor	T3-11	3-110	Advancement, Timing	1-26	1-29
Special Tools and Equipment			Description	1-16	1-23
General	2-4	2-1	Installation	3-41	3-75
Table	T2-1	2-3	Removal	3-12	3-6
Specific Gravity Conversion	T3-9	3-105	Repair	3-27	3-60
Speed Governing	1-25	1-28	Repair Standards, Advance Unit Assembly	3-63	3-113
Stop Plate and Bridge Assembly			Timing Window Cover (see Shutoff Rod and Shutoff Solenoid Assemblies).		
Installation	3-46d	3-88	Tools		
Removal	3-9c	3-4	Common	2-3	2-1
Repair	3-33d	3-67	Improvised	2-5	2-1
Supply Pump (see Fuel Supply Pump)			Special	2-4	2-1
Tappet Assembly			Special Tools Table	T2-1	2-3
Description	1-11	1-20	Torque Specifications	3-64	3-113
Installation	3-39	3-72	Troubleshooting		
Removal	3-14	3-9	Instructions	3-2	3-0
Repair	3-29	3-64	Procedures, General	3-3	3-0
Repair Standards	3-61	3-112	Purpose	3-1	3-0
Tests and Adjustments			Troubleshooting Table	T2-2	2-4
Calibration of Pump	3-58	3-104	Weight and Spider, Governor		
Delivery Valve Test	3-54	3-98	Installation	3-42	3-81
Hydraulic Head Leak Test	3-55	3-98	Removal	3-11	3-6
Hydraulic Head Port Closing Test	3-53	3-97	Repair	3-26	3-58
Installation of Pump on Stand	3-51	3-94			

By Order of the Secretary of the Army:

Official:

VERNE L. BOWERS

*Major General, United States Army,
The Adjutant General.*

CREIGHTON W. ABRAMS,
*General, United States Army,
Chief of Staff.*

Distribution:

To be distributed in accordance with DA Form 12-38, Direct/ General Support Requirements for Blocks 23, 27, 31, 35, 39, 43, 47, 51, 55, 59, 83, 131, 135, 139, 143, 147, 179, 183, 187, 191, 195, 199, 203, 207, 211, 215, 327, 331, 343, 347, 407, 411, 423, 427, and 431.

★ U.S. GOVERNMENT PRINTING OFFICE : 1995 O - 396-158

